

July 23, 1946.

J. R. DESCH ET AL

2,404,697

CALCULATING DEVICE

Filed March 21, 1942

4 Sheets-Sheet 1

FIG. 1

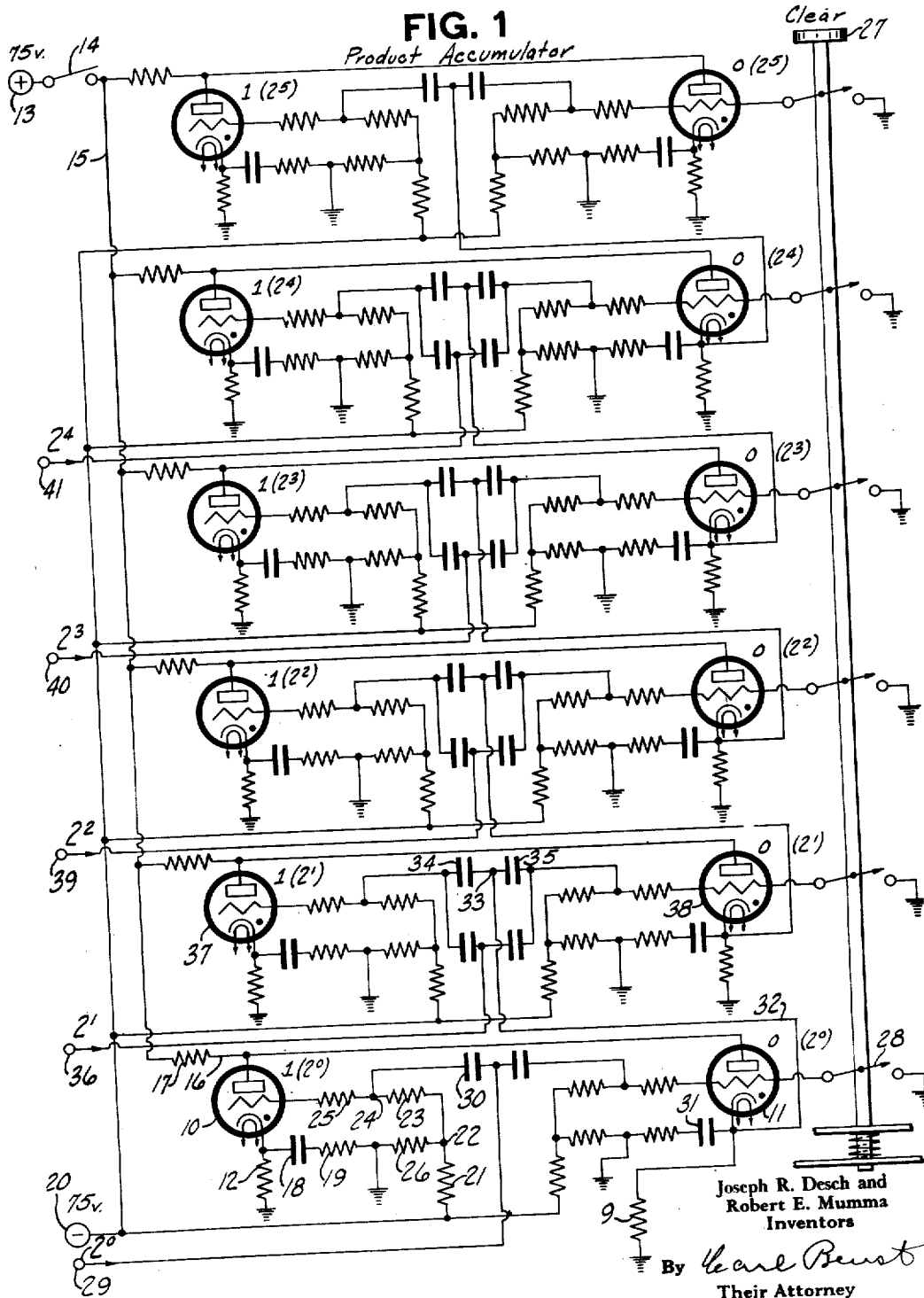

Joseph R. Desch and
Robert E. Mumma
Inventors

By *Earl Beust*
Their Attorney

July 23, 1946.

J. R. DESCH ET AL

2,404,697

CALCULATING DEVICE

Filed March 21, 1942

4 Sheets-Sheet 2

FIG. 2

Denominational Distributor

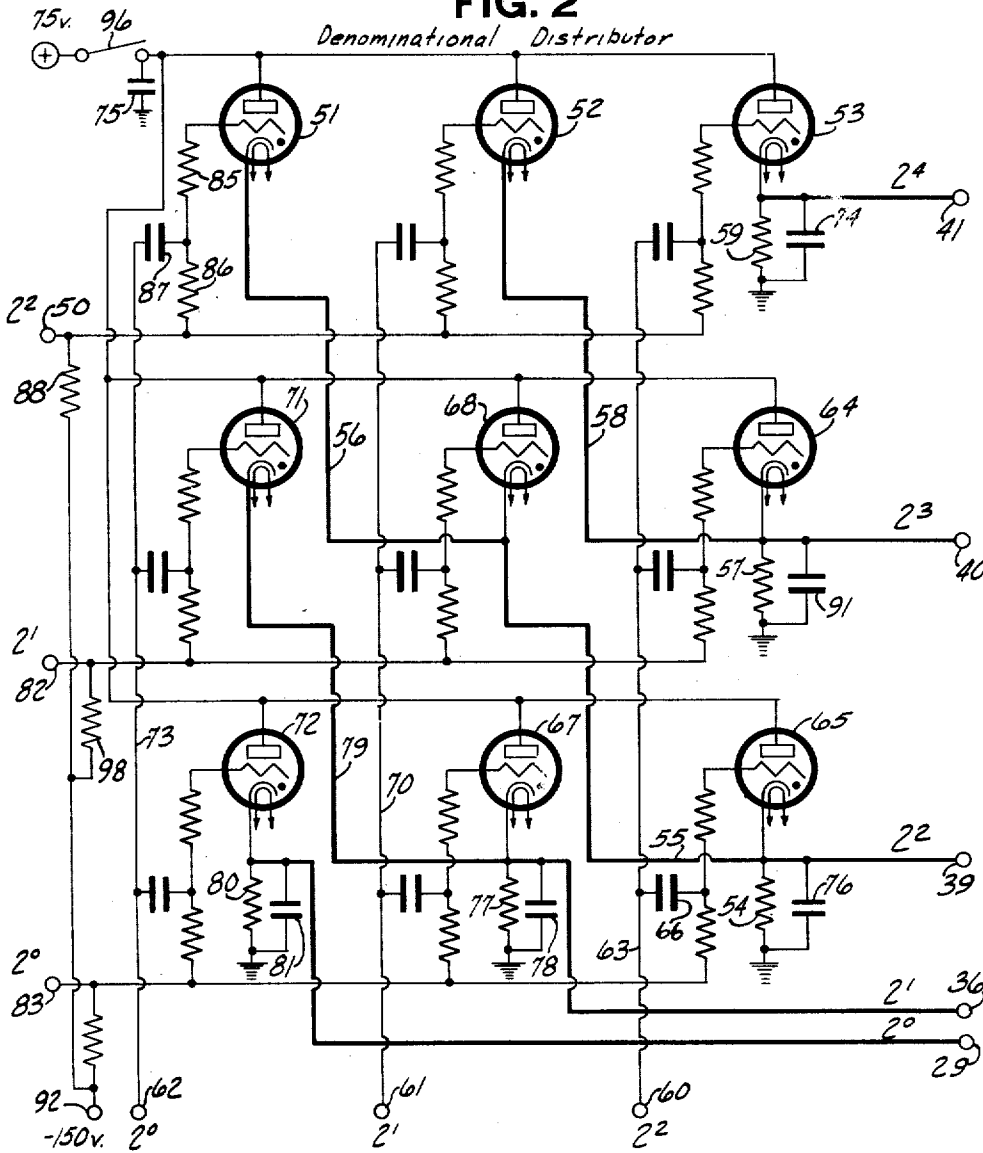

Joseph R. Desch and
Robert E. Mumma
Inventors

By *Karl Beust*
Their Attorney

July 23, 1946.

J. R. DESCH ET AL

2,404,697

CALCULATING DEVICE

Filed March 21, 1942

4 Sheets-Sheet 3

FIG. 3

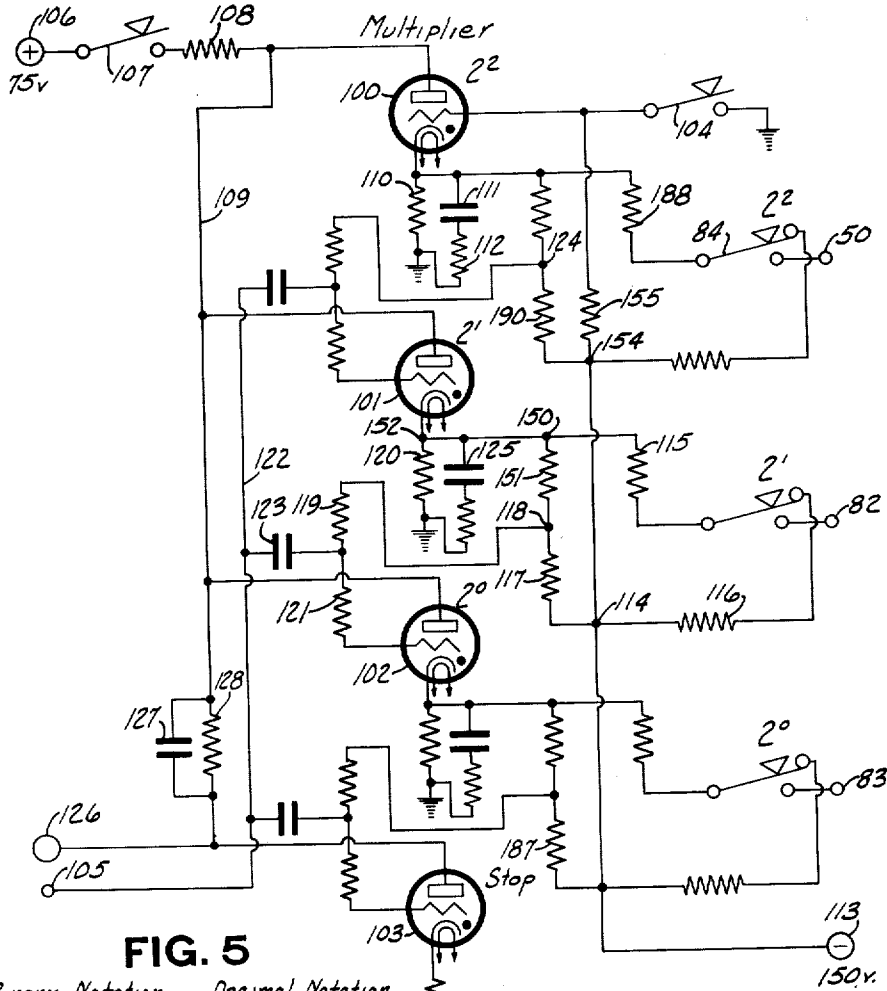

FIG. 5

Binary Notation	Decimal Notation
1	1
10	2
11	3
100	4
101	5
110	6
111	7
1000	8
1001	9
1010	10
1011	11
1100	12

Joseph R. Desch and
Robert E. Mumma
Inventors

By *Leard Benst*
Their Attorney

July 23, 1946.

J. R. DESCH ET AL

2,404,697

CALCULATING DEVICE

Filed March 21, 1942

4 Sheets-Sheet 4

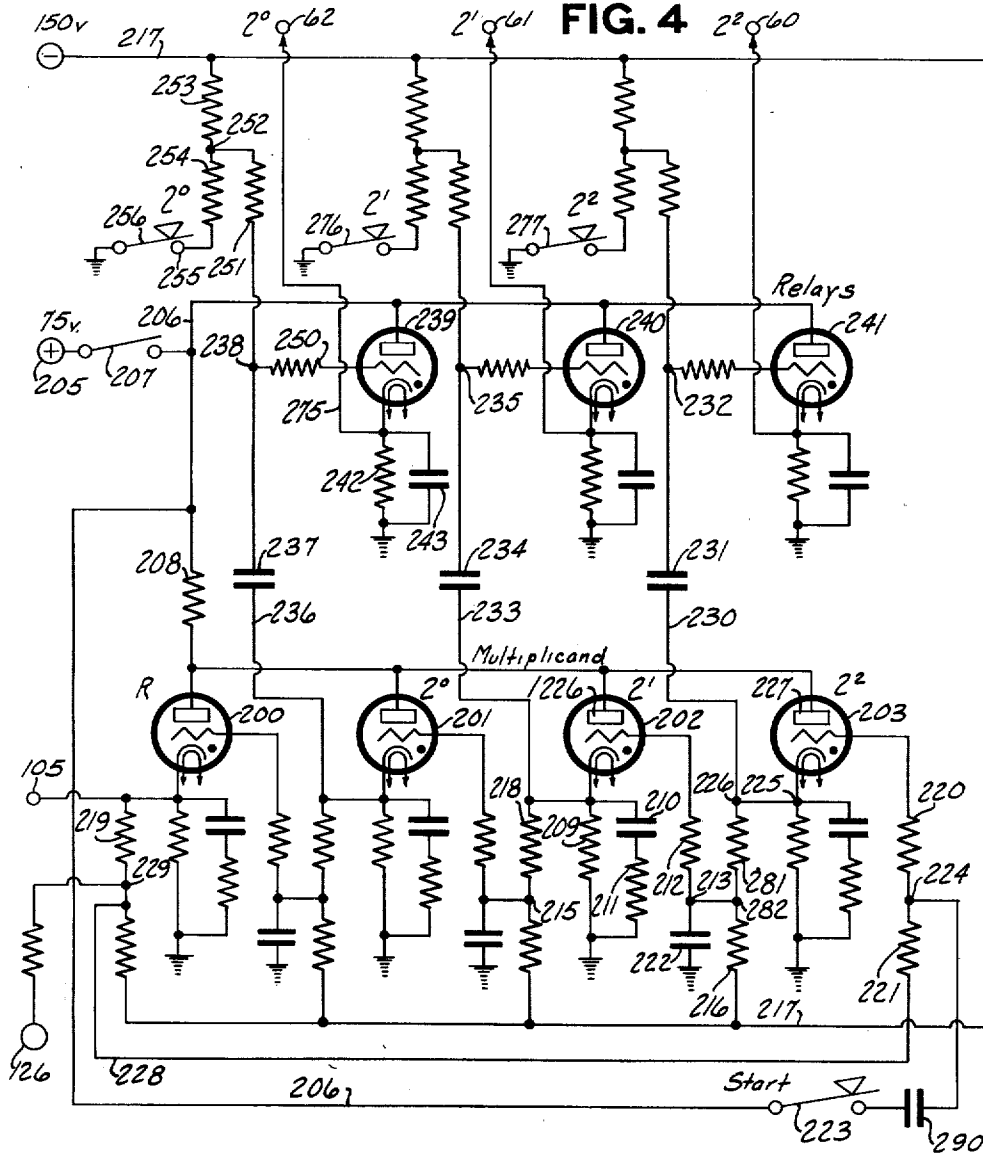

Joseph R. Desch and
Robert E. Mumma
Inventors

By *Harold Beust*
Their Attorney

UNITED STATES PATENT OFFICE

2,404,697

CALCULATING DEVICE

Joseph R. Desch, Oakwood, and Robert E. Mumma, Dayton, Ohio, assignors to The National Cash Register Company, Dayton, Ohio, a corporation of Maryland

Application March 21, 1942, Serial No. 435,746

21 Claims. (Cl. 235-80)

1

This invention relates to an electron tube calculating device and more particularly pertains to such a device for the ultra-rapid multiplying of numbers, expressed in the binary system of numerical notation, by the use of differentially controlled electron tubes.

The invention includes a product accumulator having electron tubes representing the digits, which tubes are actuated by electric impulses, a differentially-controlled electric potential generator having electron tubes representing the digits comprising a multiplier, a differentially controlled electric impulse generator having electron tubes representing the digits of a multiplicand, and an electron tube impulse producer and switching means to distribute the impulses produced under control of the multiplier and multiplicand units to the proper denominational orders of the product accumulator. The invention further includes certain manual controls for introducing the problems and for starting and resetting the devices.

The disclosed device is based on a numerical notation having two digits in each denominational order, which is known as the binary system of numerical notation. The digits are designated "0" and "1."

Therefore it is the principal object of this invention to provide an electron tube multiplying machine in which the calculation is performed solely by the flow of electrons.

Another object of the invention is to provide a multiplying machine having no moving mechanical parts except for manual entry of the problem.

Another object of the invention is to provide means for producing denominationally-designated impulses in groups which are distributed by stages to selected denominations of an accumulator.

Another object of the invention is to provide an electron tube denominational distributor, for denomination representing impulses, controlled jointly by a multiplier unit and a multiplicand unit.

Another object of the invention is to control an electron tube differential impulse generator to repeat its operation a certain number of times automatically.

Another object of the invention is to provide means to multiply two binary numbers by operating electron tubes differentially and cyclically.

With these and incidental objects in view, the invention includes certain novel features of construction and combinations of elements, the essentials of which are set forth in appended claims and a preferred form or embodiment of which

2

is hereinafter described with reference to the drawings which accompany and form a part of this specification.

Of the drawings:

Fig. 1 is a circuit diagram of the product accumulator.

Fig. 2 is a circuit diagram of the denominational distributor.

Fig. 3 is a circuit diagram of the multiplier unit.

Fig. 4 is a circuit diagram of the multiplicand unit.

Fig. 5 is a parallel table of binary notation and decimal notation.

In the binary system of numerical notation, there are but two digits, designated "0" and "1." The absence of data in a denomination is represented by "0," and the presence of a unit of data in a denomination is represented by "1." On the addition of another unit of data in a denomination having at that time a unit of data therein, there are a return to the "0" condition of said denomination and a transfer of one unit into the next higher denominational order. The following examples of additions of one unit at a time will give an understanding of the numerical system.

	0	Equivalent decimal notation
plus	1	
equals	1-2 ⁰	-1
plus	1	
equals	10-2 ¹	-2
plus	1	
equals	11-2 ⁰ +2 ¹ -1+2	
plus	1	
equals	100-2 ⁰	-4
plus	1	
equals	101-2 ⁰ +2 ¹ -4+1	

Multiplication in the binary system by partial products is accomplished in the same manner as in the decimal system; for instance,

101 (5 in the decimal system)
11 (3 in the decimal system)
plus
101
101

equals 1111 (15 in the decimal system, or 2⁴+2³+2²+2¹)

Multiplication in the binary system by successive addition is accomplished in the same manner as in the decimal system, but is much simpler, as, in multiplying by one in any denominational order, the multiplicand is set down but once. A problem of multiplying 25 by 25 (decimal notation) by successive addition will be carried out in the binary system and in the decimal system side by side for comparison.

Binary	Decimal
11001	25
X11001	X25
11001	25
11001	25
11001	25
100110001	25
	25
	25
	625

It is seen, therefore, that in the binary system the entry of data into the product accumulator need be made only once for each denominational order of the multiplier and that, in substance, the multiplication of binary numbers is the same by successive addition as it is by partial products.

The product accumulator

The product accumulator (Fig. 1) as disclosed comprises six denominational orders. Each of the denominations is represented by two gaseous triode electron tubes, one tube representing "0" and the other tube representing "1." The tubes of a denomination are coupled in such a manner that, when one tube of a pair commences conducting, the other tube of the pair is caused to become non-conducting. The pairs of tubes, each pair of which forms a denomination, are arranged in a series of ascending value, so that, upon a tube representing "1" becoming non-conducting, a change of mode of operation of the next higher denominational pair is brought about. The scheme of data representation in the accumulator will be described. The denominations will be designated 2^0 , 2^1 , 2^2 , 2^3 , 2^4 , and 2^5 , so that their decimal equivalents may be easily followed. The tubes are represented by circles. The "1" tube in the denomination 2^4 represented as conducting as an example, by being blackened, represents an accumulation of "10000" in the binary system or "16" (2^4) in the decimal system.

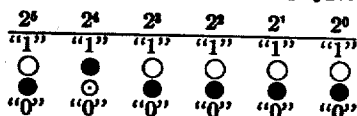

The zero condition of the accumulator is evidenced only when all the "0" tubes are conducting, which event is brought about by a special control.

Each denominational pair of tubes in the product accumulator is provided with input means by which actuating electric impulses are impressed on the pair, such impulses originating by the differential action of multiplier-multiplicand units or by reason of the "1" tube of the next lower denominational order becoming non-conducting. Each impulse represents a unit of data and causes a change in the mode of operation of the electron tube pair upon which it is impressed.

The orders of the accumulator have data entered therein in sequence the entry of the multiplicand as multiplied by one digit of the multiplier being made denomination by denomination beginning with the highest of the concerned orders of the accumulator. Thus, if the binary multiplicand "111" were being multiplied by the particular digit "1" representing the denomination 2^3 , the first entry would be made into the 2^4 denominational order of the accumulator, the second entry into the 2^3 denominational order, and

the third entry into the 2^2 order, said entries being made successively. By thus arranging the successive entry of data in the accumulator, interference of the multiplication impulses and the interdenominational transfer impulses is positively avoided, and not dependent on timing.

The accumulator, although shown to but six denominations, may be made in any number of denominations.

It is seen by reference to Fig. 1 that, there being six denominations in the product accumulator, it will accommodate in one operation the product obtained by multiplying a three-denominational-order binary number by a three-denominational-order binary number.

The gaseous triode electron tubes are of the type which has an internal voltage drop, when conducting, of about 16 volts. The cathodes are indicated conventionally as being heated, and each is grounded for operating potential through a resistance like resistance 12. A typical set of circuit values will be given the circuit elements, the resistance 12, for example, being 15,000 ohms. The anodes of each of the tubes are supplied with positive potential from a 75-volt source 13, controlled by a switch 14, which energizes a supply conductor 15 common to all the tubes in the accumulator. From said common supply conductor 15, each pair of tubes constituting a denominational order is supplied through a branch conductor such as conductor 16 through a 3000-ohm resistor such as resistor 17, whose function is for a purpose to be described. Each of the cathodes is further coupled to ground through a capacitor like capacitor 18, of .001 microfarad, and a series resistor, like resistor 19 of 2500 ohms, the resistor 19 being introduced for prevention of oscillatory phenomena. Each grid is biased from a negative 75-volt source of potential 20 through a resistor like resistor 21 of 120,000 ohms, a point like point 22, a resistor like resistor 23 of 500,000 ohms, a point like point 24, and a resistor like resistor 25 of 50,000 ohms. Points like point 22 are also grounded through a resistor like resistor 26 of 50,000 ohms. This gives each grid, normally, a controlling bias of about 12 volts over the critical potential.

A clearing or zeroizing key 27 is provided with a gang of switches, each switch such as switch 28 being furnished to connect the grid of an associated "0" tube to ground, so as to ground the control grids of all the zero tubes simultaneously to cause the product accumulator to represent zero by causing all the zero digit tubes to become conducting.

Assuming the product accumulator in zero condition, the method of counting data therein will be described first by supposing a positive potential impulse to be introduced through the 2^0 input terminal 29, said impulse being of such potential that, when it is impressed through capacitor 30, of 10 micro-microfarads, through point 24 and resistor 25 onto the grid of the "1" digit tube of the 2^0 denominational order, it will cause said digit tube to fire and become conducting. The anode of said tube, due to the resistor 17, will thereupon drop in potential, as the temporary grounding effect of capacitor 18 holds the anode at that potential, such anode potential being temporarily approximately 16 volts above the ground. At the same time, such anode drop in potential is carried by conductor 16 to the anode of tube 11, which is in a conducting condition and whose cathode is maintained temporarily at a positive potential of approximately 50 volts, determined

by resistor 9, of 15,000 ohms, by the discharge of the capacitor 31, so that the anode of the tube 11 temporarily becomes more negative than the cathode, allowing the grid to resume control, whereupon the tube 11 becomes extinguished. Thus the single impulse is counted in the 2⁰ order of the product accumulator by leaving the "1" tube in a conducting condition.

Upon the introduction of the second positive impulse through the 2⁰ terminal 29, the "0" tube will be fired and become conducting, whereupon the "1" tube will be extinguished, its grid resuming control. The rise in the potential of the cathode of tube 11, as it fires and becomes conducting, is impressed on conductor 32, through point 33, and through capacitors 34 and 35, causing the "1" tube of the 2¹ denominational order of the accumulator to fire and become conducting, thereby causing the zero tube of the same order to become extinguished. No matter which tube of the succeeding order is conducting, because the interdenominational transfer impulse is impressed through both capacitors, such as capacitors 34 and 35, it will always cause the non-conducting tube to fire and the conducting tube to become extinguished. The accumulator, after the supposed introduction of two impulses through terminal 29, now shows an accumulation of two units of data, or, expressed otherwise, data representing 2¹. Data introduced over terminal 36 represents, for each impulse, unit data of 2¹, as such an impulse introduced over terminal 36 will actuate tubes 37 and 38 to change their mode of operation from what it then is, and to cause a transfer of data to actuate the succeeding denominational order if such change in the mode of operation of the pair results in the zero tube becoming conducting. In the same manner, a single impulse over the terminal 39 will introduce in the accumulator a unit of data in the value of 2², an impulse on terminal 40 will introduce into the 2³ denominational order a unit of data equal to 2³ for each impulse, and an impulse on terminal 41 will introduce data equal in value to 2⁴ for each impulse. The total capacity of the disclosed accumulator as noted in the binary system is "11111," which is "63" as noted in the decimal system. Since the maximum multiplication accomplished by the structure disclosed is "111" by "111" in the binary system, which gives a product of "110001" in the binary system (49 in the decimal system), it is seen that the said accumulator is ample to take care of any problem that can be set up in the three place multiplier and the three place multiplicand units. The invention as disclosed permits the number of denominational orders to be increased indefinitely to accommodate more denominations for carry-over data or to accommodate a larger product.

The terminals 29, 36, 39, 40, and 41 are connected to the denominational distributor of the generated impulses, as will be described. No input terminal is furnished for the 2⁵ denomination of the accumulator, as that denomination receives data only by denominational transfer.

The denominational distributor

The denominational distributor (Fig. 2) relays and distributes impulses produced under joint control of the multiplier-multiplicand units to the product accumulator to actuate it. There are three input control conductors from the multiplier unit to the denominational distributor, ending in terminals 50, 52, and 53, representing, respectively, the 2³, 2¹, and 2⁰ denominational orders of

the multiplier. There are three input control conductors from the multiplicand unit to the denominational distributor, said conductors ending in terminals 59, 61, and 62, representing, respectively, the 2³, 2¹, and 2⁰ denominational orders of the multiplicand unit.

These conductors convey certain potentials to the grids of nine gaseous triode electron tubes, each being rendered conducting under control of associated portions of the multiplier and multiplicand units and thereafter having a self-extinguishing action. The combined influence of a potential rise in a conductor from the multiplier unit and a potential rise in a conductor of the multiplicand unit causes the firing of a particular one of the nine self-extinguishing tubes of the denominational distributor, creating a potential impulse which is routed to the proper denominational order of the product accumulator to actuate it. The three input conductors of the multiplier combine with the three input conductors of the multiplicand to give nine possible results, each of which is represented by one of the nine tubes of the distributor. A typical problem will give an understanding of the function of the distributor. For example, multiply in the binary system "111" by "111." This problem will identify the function of each of the tubes in the denominational distributor, as it provides a digit in every order of every stage of the multiplication. As has been said, the highest digit of the multiplier is first used, and therefore the problem may be expressed in this manner:

2 ⁵	2 ⁴	2 ³	2 ²	2 ¹	2 ⁰	(Denominational order)	
×		1	1	1		(multiplicand) = 2 ² +2 ¹ +2 ⁰	
		1	1	1		(multiplier) = 2 ² +2 ¹ +2 ⁰	
		1	1	1		(first stage) = 2 ² +2 ¹ +2 ⁰	
		1	1	1		(second stage) = 2 ³ +2 ² +2 ¹	
		1	1	1		(third stage) = 2 ³ +2 ² +2 ¹	
	1	1	0	0	0	1	(product) = 2 ⁵ +2 ⁴ +2 ³

It is seen that, in the first stage of the multiplication, the highest order multiplier digit is employed, which is, in the denominational distributor, represented by the multiplier terminal 50 (Figs. 2 and 3). This terminal is connected to the grids of the gaseous triodes 51, 52, and 53, whose cathodes are respectively connected to the product accumulator terminals 39, 40, and 41, leading to the product accumulator banks (Fig. 1) representing 2³, 2², and 2¹. Referring to the first stage of the multiplication, it is seen that a unit of data is to be entered into each of the last-named denominational orders of the accumulator. By impressing a positive potential on terminal 50 (Fig. 2) sufficient to relieve the bias on the grids of tubes 51, 52, and 53 to a point just short of firing, each of the said tubes 51, 52, and 53 is primed to be responsive by firing. If the grid of any one of the primed tubes is given a positive potential impulse by the multiplicand unit, through associated respective terminals 60, 61, and 62, sufficient to overcome the relieved bias, such tube will fire and become conducting. Such multiplicand impulses are adjusted so as to be insufficient to fire tubes of the denominational distributor which are not relieved of the full bias potential. The cathode of a fired tube will rise in potential, due to the resistance in the cathode supply circuit, delivering a positive potential impulse to the associated one of the terminals 39, 40, and 41 actuating the corresponding bank of the product accumulator. The cathode of the tube 51 (also connected to the cathodes of tubes 52 and 53) is connected to ground through resistor 54 of 50,000 ohms by means of conductors

55 and 56. The cathode resistor 57 is common to tubes 54 and 52, the cathode of the tube 52 being connected thereto by conductor 58. The cathode resistor 59 is connected to tube 53 alone. The cathode resistor 77 is connected to the cathode of tube 67 and to the cathode of tube 71 by conductor 79. The cathode resistor 80 is connected alone to tube 72. Multiplicand terminals 60, 61, and 62 in the supposed problem are given a positive potential impulse in sequence, beginning with terminal 60 and ending with terminal 62, for each stage of the multiplication. In problems in which there is no multiplying digit in a given denomination, no impulse for that denomination reaches the distributor. Terminal 60, representing 2^1 , is coupled by conductor 63 to the grids of tubes 55, 64, and 53 each through a capacitor like capacitor 66 of 10 micro-microfarads. In the same manner, the grids of the tubes 52, 68, and 57 are coupled, each through a capacitor, to the common conductor 70 connected to the terminal 61 representing the 2^1 denominational order of the multiplicand, and, in a like manner, each of the tubes 51, 71, and 72 is coupled, through a capacitor, to a conductor 73 connected to the terminal 62 representing the 2^0 denominational order of the multiplicand.

In the first stage of the multiplication, the first tube of the denominational distributor tubes to become conducting (for the supposed problem) is the tube 53, followed in order by tubes 52 and 51. The reason for this order is that in the first stage the tubes 51, 52, and 53 are relieved of their bias and the terminals 60, 61, and 62 in that order are given the necessary positive potential firing impulse in sequence. The firing of each of the tubes 52, 53, and 51 produces an impulse, the first impulse being impressed on the terminal 41, the second on the terminal 40, and the third on the terminal 39.

After one of the tubes of the denominational distributor has fired and become conducting, it is self-extinguished by reason of the fact that the cathode and anode of each tube are each dynamically coupled to ground, which fact, in conjunction with a resistance and capacitance in parallel in the cathode supply, and the distributed inductance in the anode-cathode circuit, causes an oscillatory rise in cathode potential which overshoots the anode potential, extinguishing the tube. For tube 53, for instance, the capacitor 74 of 100 micro-microfarads, the resistor 59 of 50,000 ohms in the cathode circuit, and the relatively large capacitor 75 coupling the common anode supply to ground constitute such a self-extinguishing circuit. The tubes 52 and 64 are both served by the resistor 57 and the capacitor 61, the cathodes of both tubes being connected by conductor 58.

In the same manner for tubes 65, 68, and 51, whose cathodes are connected by conductors 55 and 56, the resistor 54 and the capacitor 76 supply the self-extinguishing circuit elements. For the tubes 67 and 71, the resistor 77 and the capacitor 78 serve the same purpose by reason of the common conductor 79. The tube 72 is served by the resistor 80 and the capacitor 81. The cathode resistors and capacitors are the same for all the distributor tubes.

The operating potentials are supplied as follows: for the anodes, 75 volts positive, and for the normal grid bias, 150 volts negative. This 150-volt negative supply is obtained by connection to terminal 82, which normal potential, by connection through the terminals 80, 82, and 83

(Fig. 3), is caused to give a resultant potential of 50 volts negative on the grids of distributor tubes connected to the multiplier unit by keys, such as key 84 (Fig. 3), which resultant potential is reduced to 23 volts negative when the corresponding tube of the multiplier is conducting. The 23 volts negative potential of the grid is the relieved condition under which the tube is deemed primed, said potential being made more positive than 10 volts negative with respect to the cathode by impulses from the multiplicand terminals, causing such primed tubes to fire.

Resistors such as resistors 85 and 86 (Fig. 2) are of 50,000 ohms and 500,000 ohms, respectively. Resistors such as resistor 88 are of 350,000 ohms.

A switch 89 is provided to complete the anode supply potential to all the self-extinguishing tubes of the denominational distributor unit.

The multiplier unit

The multiplier (Fig. 3) includes four gaseous triodes, three of them, 100, 101, and 102, representing the denominational orders 2^2 , 2^1 , and 2^0 of the multiplier, the fourth tube, 103, being a "stop" tube. The tubes 100 to 103 are caused to be operated in sequence, the first of said tubes, tube 100, being fired by momentarily closing a switch 104, which grounds the grid. The remaining tubes 101, 102, and 103 are caused to become conducting in sequence in response to positive potential impulse signals received through terminal 105, which impulses are received from the multiplicand unit (Fig. 4), as will be described.

The anodes of the tubes of the multiplier are supplied, through the terminal 106, under control of a switch 107, with 75 volts positive potential, through a resistor 108 of 3,000 ohms and a common conductor 109.

The cathodes of each of the tubes 100, 101, and 102 are grounded through a 15,000-ohm resistor, like resistor 110, in parallel with a capacitor of .002 microfarad, like capacitor 111, in series with a resistor of 2,500 ohms, like resistor 112. The grids of each of the tubes 101, 102, and 103 are given negative bias through the resultant effect of connection to terminal 113 of 150 volts negative with respect to ground, through a point like point 114, through a network of resistors, like resistors 116 (or 98, Fig. 2, when key switch 2^1 is closed), 115, 151, 117, 119, and 121 of the values 350,000 ohms, 200,000 ohms, 200,000 ohms, 300,000 ohms, 500,000 ohms, and 50,000 ohms, respectively. Points like point 150 are connected to the cathode of the preceding tube of the series at a point like point 152, which is grounded through a resistor like resistor 120 of 15,000 ohms. This gives the grids of tubes 101, 102, and 103 a normal negative bias of 57 volts with respect to their cathodes, which is sufficient to prevent the firing of said tubes, their cathodes being connected to points like point 152 to give them a negative potential in the normal non-conducting condition of 8 volts. The grid of tube 100 is given a controlling negative bias of 150 volts with respect to ground by being connected to point 154 through a 500,000-ohm resistor 155. Resistor 157 is of 350,000 ohms instead of the 300,000 ohms stated for other corresponding resistors.

The closing of any one of the keys 2^2 , 2^1 , or 2^0 (Fig. 3) adjusts the bias on the grid of the associated tube of the multiplier unit and the associated tubes of the horizontal row of the denominational distributor, making the bias on the grids of the tubes of the denominational distributor

(Fig. 2) as are associated with the depressed closed key, about 59 volts negative. The consequent potential upon the grids of the multiplier tubes of the next lower denominational order will be about 65 volts negative.

As the key switch 104 is momentarily closed, grounding the grid of the 2² tube 100, the tube 100 fires and becomes conducting, and the terminal 50 (if key 84 is on the lower contact), connected to the cathode of the 100 tube through resistor 188, is given a potential rise of approximately 36 volts, which results in relieving the bias on the grids of the tubes 51, 52, and 53 of the denominational distributor (Fig. 2) to approximately 23 volts negative.

When an impulse is impressed upon the terminal 105 (Fig. 3) from the multiplicand unit, it is thereby impressed upon the grids of the tubes 101, 102, and 103 by means of a common conductor 122 and capacitors, such as capacitor 123 of 10 micro-microfarads. As the grid of tube 101 is connected to point 124, it receives a positive elevation of potential while the tube 100 is in conducting condition, which causes the grid of tube 101 to be relieved or primed so as to be more susceptible to firing than the tube 102 or 103, and consequently the potential impulse impressed on the terminal 105 is made of a value which discriminates between the primed and the unprimed tubes, and fires tube 101, whose grid is connected to the cathode of an already conducting tube. Therefore, when tube 100 is conducting, only tube 101 will fire in response to an impulse from the multiplicand unit. When tube 101 fires, its cathode capacitor 125 of .002 microfarad will begin to charge, and, due to the common 3,000-ohm resistor 108 in the anode potential supply line, a sudden drop in potential in the conductor 109 occurs, with a consequent drop in the anode potential of the tube 100, which previous to that time has been within about 16 volts of the potential of its cathode. Such sudden drop in the potential of the anode of tube 100 thereby extinguishes it, as its cathode potential is temporarily maintained by the charge on capacitor 111. This extinguishing of one tube upon the firing of a second tube by causing its anode potential to become less than the cathode potential has been explained before in connection with the product accumulator. It is seen that tubes 101, 102, and 103 are caused to be fired step by step in sequence in response to the positive potential impulses impressed upon the terminal 105 by the multiplicand unit.

The firing of the tube 103 is only to provide a negative potential at the terminal 126, which negative potential is brought about by reason of the drop of the anode potential of tube 103 due to the resistance in its anode supply. Such negative potential is impressed upon the multiplicand unit to stop the recycling operation of the multiplicand tubes, as will be explained.

When tube 103 fires, capacitor 127 and resistor 128 together provide the circuit function in extinguishing any other conducting tube whose anode is given its potential by anode conductor 109, just as though the capacitor and resistor were in the cathode supply circuit of tube 103. Therefore capacitor 127 is of the same value as capacitor 111, and resistor 128 is of the same value as resistor 110. The resistor in the cathode supply of tube 103 is an oscillation-suppressing resistor of 2,500 ohms corresponding to resistor 112 having the same function for tube 100. By placing most of the resistance in the anode cir-

cuit of tube 103, a greater potential drop is available at terminal 126.

It is seen, therefore, that manually selected ones of terminals 50, 82, and 83 are caused to be given an elevation of potential, one after another, under control of the multiplicand unit, the keys like key 84 being selecting keys for setting up the digits of the multiplier.

The multiplicand unit

The multiplicand unit (Fig. 4) includes tubes 200, 201, 202, and 203 of the gaseous triode type, such as the tubes heretofore considered. Tubes 201, 202, and 203 represent, respectively, 2⁰, 2¹, and 2². The tube 200 is an operation recycling control tube. The multiplicand tubes are connected in a circuit whereby, upon initiation of an operation by firing the tube 203, the tubes 202, 201, and 200 are caused to fire automatically and become extinguished in that order in succession. Recycling tube 200, upon firing, initiates the commencement of another sequential operation of the multiplicand unit by giving a positive potential elevation to the grid of the tube 203. When the terminal 126 (Figs. 3 and 4) receives the negative potential, due to the firing of the "stop" tube of the multiplier, as has been explained, the recycling impulse of the tube 200 is blocked and the recycling of the sequential operation of the tubes of the multiplicand ceases.

Terminal 205 is the source of a 75-volt positive anode supply potential which is impressed on a common conductor 206 when switch 207 is closed. A 3,000-ohm resistor 208 is included in the portion of said anode supply conductor serving the tubes 200, 201, 202, and 203. Each of the cathodes of said tubes 200 to 203 inclusive is grounded through a 15,000-ohm resistor, such as resistor 209, in parallel with a capacitor and resistor in series, like capacitor 210 of .002 microfarad and like resistor 211 of 2,500 ohms. Each of the grids, except as will be explained for tube 203, receives its biasing potential by being connected through a resistor of 500,000 ohms, like resistor 212, a point, like point 213, a point, like point 282, and a resistor of 150,000 ohms, like resistor 216, to a negative 150-volt supply conductor 217. Points like point 213 are grounded through a capacitor of 250 micro-microfarads, such as capacitor 222. Each cathode is connected to a point like point 215 through a resistor like resistor 218 of 75,000 ohms. Departing from the repeating pattern of the circuit elements of the multiplicand unit, the resistor 219 is of 150,000 ohms, the resistor 220 is of 50,000 ohms, the resistor 221 is of 500,000 ohms, and the capacitor 290, coupled to the source of positive potential, is 50 micro-microfarads. With the values of the circuit elements shown, upon the closing of the start switch 223, which connects the positive potential conductor 206 through capacitor 290 to point 224 leading to the grid of the tube 203, representing 2², the grid of said tube 203 is caused to become sufficiently positive to fire said tube, and, upon said tube becoming conducting, point 225 rises in potential, which potential is impressed through point 226, resistor 281, point 282, point 213, and resistor 212 onto the grid of the tube 202, representing 2¹, which thereupon fires and becomes conducting. As tube 202 is becoming fully conducting, capacitor 210 is charging, which, by lowering the potential of anode 1226 due to the common resistor 208 in an anode supply circuit, lowers the potential of the anodes of tubes "R," 2⁰, 2¹, and 2², which

drop in potential of anode 227 of the 2^o tube is more than 15 volts, to a point more negative than the potential of its cathode, causing said tube to become extinguished and permitting the grid to regain control. After tube 202 becomes conducting, the rise of its cathode potential causes tube 201 to fire and become conducting, extinguishing the 2^o tube 202, which in turn causes the recycling tube "R" to fire and become conducting, extinguishing the 2^o tube 201. As the cathode of the "R" tube rises in potential, a positive potential impulse is sent over terminal 105 to the multiplier (see Fig. 3), causing the multiplier tubes to advance in operation one step. A positive potential rise is impressed upon conductor 228 (Fig. 4), leading to the grid of the tube 203, to cause a recycling of the multiplicand unit. However, at the time the "R" tube 200 fires the third time, the "stop" tube 103 (Fig. 3) is also caused to fire, and terminal 126 (Figs. 3 and 4) is given a negative potential change, so that, regardless of the rise of the cathode potential of the "R" tube 200, point 229 is made so negative that any positive rise in potential of the cathode of the "R" tube 200, due to its firing, will not initiate the firing of tube 203 and a consequent recycling of the multiplicand. This stops the operation of the multiplicand unit. Capacitors such as capacitor 222 are timing capacitors, and capacitor 290 of 50 micro-microfarads delays the rise in potential of the grid of tube 203 until the negative potential arrives over terminal 126. The operation of multiplication occurs in such a short time that even the momentary manual closing of switch 223 is ample to keep the switch terminal 35 of capacitor 290 at a fixed potential.

As the tubes 203, 202, and 201 become conducting in sequence, the positive rise in their cathode potential is impressed on associated couplings. Thus, the rise in cathode potential of tube 203 is conveyed over conductor 230 and, through capacitor 231 of 10 micro-microfarads, to point 232. In a like manner, the rise in cathode potential of tube 202, as it fires, is conveyed over conductor 233, through capacitor 234 of 10 micro-microfarads, to point 235. In a like manner, the rise in cathode potential of tube 201, as it fires, is conveyed over conductor 236, through capacitor 237 of 10 micro-microfarads, to point 238. Tubes 239, 240, and 241 are relay tubes for tubes 201, 202, and 203, respectively, transmitting to terminals 62, 61, and 60 a positive potential impulse as the associated relay tube is fired. Tubes 239, 240, and 241 are self-extinguishing tubes of the gaseous triode type described, having in their cathode supply a resistor, like resistor 242 of 50,000 ohms, and a capacitor like capacitor 243 of 100 micro-microfarads. Each of the grids of the self-extinguishing tubes 239, 240, and 241 is connected through a resistor like resistor 250 of 50,000 ohms, a point like point 250, a resistor like resistor 251 of 500,000 ohms, a point like point 252, and a resistor like resistor 253 of 250,000 ohms to the 150-volt negative supply conductor 217. Points like point 252 are connected through a resistor like resistor 254 to a terminal like terminal 255, which may be connected by a key switch like switch 256 to ground. These switches, when closed, ground the terminal 255 and reduce the bias on the grid of the associated relay tube. For example, the closing of switch 256 makes the potential of the grid of the tube 239 more positive by 125 volts than the normal negative potential of 150 volts, which is near enough to the critical point to prime the tube

so that it will be fired in response to the potential rise received at point 238 as tube 201 fires. As the tube 239 fires, its cathode rises in potential due to the resistance in its cathode supply, which rise in potential is conveyed over a conductor like conductor 275 to the associated terminal 62, representing the 2^o power. Thus, by the selective closing of switches 256, 276, and 277, it is determined which of the terminals of terminals 60, 61, and 62 will receive a positive potential impulse as the tubes of the multiplicand fire in succession.

It is apparent that, as far as the novelty of the invention is concerned, the relay tubes could be dispensed with and the terminals 60, 61, and 62 could be considered as connected through proper electrostatic couplings and switches directly to the cathodes of the digit-representing tubes of the multiplicand unit. The tubes 239, 240, and 241, being self-extinguished by reason of their resistance-capacitance coupling to ground, pass on the impulses and are ready for firing on the next cycle of operation of the multiplicand unit.

Operation

It is seen, therefore, that, in the operation of the device, the anode supply switches 14, 96, 107, and 207 (Figs. 1, 2, 3, and 4, respectively) are first closed, the Clear key 27 (Fig. 1) is closed temporarily to fire all the zero tubes of the product accumulator, the selected multiplier and multiplicand keys are closed (Figs. 3 and 4), the key 104 of the multiplier (Fig. 3) is closed, and finally the start key 223 (Fig. 4) is closed. Under these conditions, and for the problem expressed as an example, wherein all the digit keys are selected, impulses will be impressed upon the terminals of the denominational distributor from the multiplier and the multiplicand and from the denominational distributor to the product accumulator according to the following schedule:

	Input terminals to distributor (Figs. 2, 3, and 4)	Input terminals to product accumulator (Figs. 1 and 2)
First stage:		
2 ¹ X 2 ⁰	50-60	41
2 ¹ X 2 ¹	50-61	40
2 ¹ X 2 ²	50-62	39
Second stage:		
2 ¹ X 2 ⁰	82-60	40
2 ¹ X 2 ¹	82-61	39
2 ¹ X 2 ²	82-62	38
Third stage:		
2 ² X 2 ⁰	83-60	39
2 ² X 2 ¹	83-61	38
2 ² X 2 ²	83-62	29

Such impulses entered into the product accumulator will give the maximum binary product 110001 for the capacity of the disclosed embodiment.

The values for the circuit elements that have been presented in this disclosure are relative and are not to be deemed to restrict the invention in that respect, as the novelty of the invention resides in their relative interaction and not in the actual values given as an example. The time constants are so adjusted that a multiplication is accomplished in approximately .001 of a second after the start switch is closed. It is apparent that, if any of the digit keys of the multiplicand unit or the multiplier unit are not used, the multiplicand and the multiplier units are nevertheless operated, but the change in potential due to the firing of any multiplier tube or multipli-

cand tube not selected is not conveyed to the denominational distributor. Therefore, no matter what the size of the multiplier or the multiplicand, the time consumed in one multiplying operation is the same.

Instead of the method of selecting the digits of the multiplier and the multiplicand by key switches, wherein the control is located between the multiplier or the multiplicand and the denominational distributing unit, the same results could be gotten by bridging the connections between the multiplier tubes or the multiplicand tubes so as to cut out any particular tube not wanted in the sequence of operation, or stopping the operation of selected tubes in any manner.

A table of binary-decimal equivalents is given in Fig. 5 for convenience.

While the form of the invention herein shown and described is admirably adapted to fulfill the objects primarily stated, it is to be understood that it is not intended to confine the invention to the one form or embodiment herein disclosed, for it is susceptible of embodiment in various forms all coming within the scope of the claims which follow.

What is claimed is:

1. In combination a plurality of electron tubes each representing a denomination of a multiplier so connected in a circuit that they are operable one at a time in sequence in response to each of commonly received electric impulses; and a second plurality of electron tubes arranged in a chain, each plurality representing a denomination of a multiplicand so connected in a circuit that conduction in one tube renders the next tube in the chain conducting, said group being connected to said first group of tubes so that at the end of a complete sequential cycle of operation of the multiplicand tubes a potential impulse is impressed upon the multiplier tubes to operate them a step in the sequence.

2. In combination a plurality of gaseous electron tubes, each representing a denomination of a multiplier, so connected in a circuit that they are operable one at a time in sequence, in response to each of commonly received electric impulses; and a second plurality of gaseous electron tubes arranged in a chain, each plurality representing a denomination of a multiplicand, so connected in a circuit that conduction in one tube renders the next tube in the chain conducting, said group being connected to said first group of tubes so that at the end of a complete sequential cycle of operation of the multiplicand tubes, a potential impulse is impressed commonly upon the multiplier tubes to operate them a step in the sequence.

3. In combination a plurality of electron tubes each representing a digit of a multiplier so connected in a circuit that they are operable one at a time in sequence in response to each of commonly received electric impulses; a second plurality of electron tubes each representing a digit of a multiplicand so connected in a circuit that they are automatically rendered conductive in sequence and connected to said first group of tubes so that at the end of a cycle of operation of the multiplicand tubes a potential impulse is impressed upon the multiplier tubes; and an output circuit for each tube of the multiplier which circuit is given a rise in potential as the associated tube becomes conducting.

4. In combination a plurality of electron tubes representing digits of a multiplier so connected in a circuit that they are operable one at a time

in sequence in response to each of commonly received electric impulses; a second plurality of electron tubes representing the digits of a multiplicand so connected in a circuit that they are automatically rendered conductive in sequence and connected to said first group of tubes so that at the end of a cycle of operation of the multiplicand tubes a potential impulse is impressed upon the multiplier tubes; and means associated with each multiplicand tube which means is given an electric potential impulse when the associated tube becomes conductive.

5. In combination, a plurality of gaseous electron tubes, each representing a digit of a multiplier and connected in a circuit so they are operable one at a time in sequence, in response to each of commonly received electric impulses; means to render the first tube of the sequence operable; a second plurality of gaseous electron tubes, each representing a digit of a multiplicand, so connected in a circuit that they are automatically rendered operable in sequence and connected to said first group of tubes so that at the end of a cycle of operation of the multiplicand tubes a potential impulse is impressed commonly upon the multiplier tubes; means to start the sequential operation of the multiplicand tubes; an output circuit for each tube of the multiplier tubes, each of which output circuits is given a rise in potential as the associated tubes become conducting; and an output circuit for each of the multiplicand tubes, each of which circuits is given a rise in potential as the associated multiplicand tube becomes conducting.

6. In combination, a plurality of gaseous electron tubes, each representing a digit of a multiplier and so connected in a circuit that they are operable one at a time in sequence, in response to each of commonly received electric impulses; a second plurality of gaseous electron tubes, each representing a digit of a multiplicand and so connected in a circuit that they are automatically rendered conductive in sequence, and connected to said first group of tubes so that at the end of a cycle of operation of the multiplicand tubes a potential impulse is impressed commonly upon the multiplier tubes; an output circuit for each of the multiplier tubes, each of which circuits is given a rise in potential as the associated tube becomes conducting; an output circuit for each of the multiplicand tubes, each of which circuits is given a rise in potential as the associated tube becomes conducting; and a means associated with each output circuit to connect said circuit with said tube and disconnect said circuit from said tube as selectively determined.

7. A first plurality of electron tubes each tube representing a digit of a multiplier; a second plurality of tubes each tube representing a digit of a multiplicand; means supplying operating energy to said tubes; means connecting the multiplicand tubes to cause said multiplicand tubes to automatically become conducting one at a time in sequence; means connecting the multiplier tubes to cause the multiplier tubes to become conducting one at a time in sequence; means coupling the first and second groups of tubes so that each step of operation of the first group is caused by the completion of a cycle of sequential operation of said second group; output means for each of said tubes, said output means being given a rise in potential each time the associated tube becomes conducting; selective means to determine

15

whether any of said output means should be given said rise in potential or not as the associated tube becomes conducting; and a plurality of tubes connected in groups, each group representing an output means of the multiplier tubes by which the group is controlled and connected in other groups each of which represents the output means of one of the multiplicand tubes, and connected in third groupings, each of which represents the joint control of a digit representing tube of the multiplier and a digit representing tube of the multiplicand whose product is represented in the same denomination.

8. In combination, a plurality of electron tubes representing denominations of a multiplier so connected in a circuit that they are operable one at a time in sequence, in response to each of commonly received electric impulses; a second plurality of electron tubes representing the denominations of a multiplicand so connected in a circuit that they are automatically rendered conducting in sequence, and connected to said first group of tubes, so that at the end of a cycle of operation of the multiplicand tubes a potential impulse is impressed upon the multiplier tubes; a plurality of means each representative of a product of a multiplicand digit as multiplied by a multiplier digit, said means including a plurality of electron tubes equal in number to the number of denominations in the multiplier times the number of denominations in the multiplicand; and connections between the product representing tubes, a source of electric energy, and the multiplier and multiplicand tubes whereby any one of said product tubes is rendered conducting by reason of the multiplicand tube and multiplier tube whose product it represents, being simultaneously in a conducting condition.

9. In combination, a multiplier unit, including an electron tube for each of a plurality of denominations, based on the binary system of numerical notation; a multiplicand unit, including an electron tube for each of a plurality of denominations, based upon the binary system of numerical notation, and a recycling means; connections between the tubes of the multiplicand unit whereby the tubes are caused to become conducting one at a time in sequence automatically, said sequential operation being automatically repeated by the recycling means; couplings between the multiplier unit and the multiplicand unit; connections between the tubes of the multiplier whereby they are made to become conducting one at a time in sequence, each step of the sequential operation being caused through said couplings by the completion of a sequential cycle of the multiplicand operation; and means under control of the multiplier unit for causing the multiplicand unit recycling means to cease its repeat operations at the conclusion of one sequential cycle of operation of the multiplier unit.

10. In combination, a multiplier unit including an electron tube for each of a plurality of denominations based on the binary system of numerical notation; a multiplicand unit including an electron tube for each of a plurality of denominations based upon the binary system of numerical notation, and a recycling means; connections between the tubes of the multiplicand unit whereby the tubes are caused to become conducting one at a time in sequence, said sequential operation being automatically repeated by the recycling means; couplings between the multiplier unit and the multiplicand unit; connections between the tubes of the multiplier unit whereby

16

they are made to become conducting one at a time in sequence, each step of the sequential operation being caused through said couplings by the recycling means of the multiplicand unit on the completion of a cycle of said multiplicand unit; means under control of the multiplier unit for causing the multiplicand unit recycling means to cease its operation at the conclusion of one sequential cycle of operation of the multiplier unit; an output conductor for each tube of the multiplier unit which output conductor is connected to an electrode of the associated tubes so as to receive an electric potential rise as such tube is operated; an output conductor for each tube of the multiplicand unit so connected to an electrode of the associated tube that such tube is given an electric potential rise as the associated tube is operated; controls whereby to start the operation of the multiplier units and the multiplicand units; a plurality of responsive means, each of which is associated with an output conductor of the multiplier unit and one of the output conductors of the multiplicand unit so as to be responsive to given an electric potential change when the associated conductors receive their potential rises at the same time; and a plurality of conductors each associated with one or more of the responsive means, which conductors are given an electric potential change as any one of the responsive means with which they are associated responds.

11. In combination, a multiplier unit, including an electron tube for each of a plurality of denominations based on the binary system of numerical notation; a multiplicand unit including an electron tube for each of a plurality of denominations based on the binary system of numerical notation, and a cycling means; connections between the tubes of the multiplicand unit whereby the tubes are caused to become conducting one at a time in sequence, said sequential operation being automatically repeated by the recycling means; couplings between the multiplier unit and the multiplicand unit; connections between the tubes of the multiplier unit whereby they are made to become conducting one at a time in sequence, each step of the sequential operation being caused through said couplings by the recycling means upon completion of the sequential cycle of operation of the multiplicand unit; means under control of the multiplier unit for causing the multiplicand unit to cease its repeat operation at the conclusion of one sequential cycle of operation of the multiplier unit; controls whereby to start the operation of the multiplier unit and the multiplicand unit; an output conductor for each tube of the multiplier unit, which output conductor is connected to an electrode of the associated tube so as to receive a change in electric potential as each tube is operated; an output conductor for each tube of the multiplicand unit so connected to an electrode of the associated tube that each conductor is given a change in electric potential as the associated tube is operated; a plurality of means, each of which is associated with a conductor of the multiplier unit and one of the conductors of the multiplicand unit so as to respond when the associated conductors receive their potential change at the same time; a plurality of conductors each associated with one or more of the responsive means and each having a designated numerical value, which conductors are given an electric potential impulse as any one of the responsive means with which they are associated

responds; and an accumulator of data having denominational orders based upon the binary system of numerical notation, which is actuated by the changes of potential of the conductors associated with the responsive means, said conductors and the denominational orders of the accumulator being so connected that the accumulator is actuated to have data entered therein corresponding to the product represented by multiplying the value of the multiplicand tubes by the value of the multiplier tubes.

12. In combination, a multiplier unit, including an electron tube for each of a plurality of denominations based on the binary system of numerical notation; a multiplicand unit including an electron tube for each of a plurality of denominations based on the binary system of numerical notation and a recycling means; connections between the tubes of the multiplicand unit whereby the tubes are caused to become conducting one at a time in sequence, said sequential operation being automatically repeated by the recycling means; couplings between the multiplier unit and the multiplicand unit; connections between the tubes of the multiplier unit whereby they are made to become conducting one at a time in sequence, each step of the sequential operation being caused through the couplings by the recycling means upon completion of the sequential cycle of operation of the multiplicand unit; means under control of the multiplier unit for causing the multiplicand unit to cease its repeat operation at the conclusion of one sequential cycle of operation of the multiplier unit; controls whereby to start the operation of the multiplier unit and the multiplicand unit; an output conductor for each tube of the multiplier unit, which output conductor is connected to an electrode of the associated tube so as to receive a change in electric potential as each tube is operated; an output conductor for each tube of the multiplicand unit so connected to an electrode of the associated tube that each conductor is given a change in electric potential as the associated tube is operated; a plurality of means, each of which is associated with a conductor of the multiplier unit and one of the conductors of the multiplicand unit so as to respond when the associated conductors receive their potential change at the same time; a plurality of conductors each associated with one or more of the responsive means and each having a designated numerical value, which conductors are given an electric potential impulse as any one of the responsive means with which they are associated responds; an accumulator of data having denominational orders based upon the binary system of numerical notation, which is actuated by the changes of potential of the conductors associated with the responsive means, said conductors and the denominational orders of the accumulator being so connected that the accumulator is actuated to have data entered therein corresponding to the product represented by multiplying the value of the multiplicand tubes by the value of the multiplier tubes; and manipulative means to select which of the multiplicand tubes and which of the multiplier tubes when operative shall impress a potential change upon the associated responsive means.

13. In combination a plurality of electron tubes each representing a digit; connections between the tubes whereby they may be made conducting one at a time in sequence, each step of the sequence being in response to an electric impulse

commonly impressed upon all the tubes; a second plurality of electron tubes divided into groups, each group being associated with one of the tubes of the first named plurality; means common to the tubes of a group normally rendering the tubes inoperative; and connections between a tube of the first plurality and associated group whereby when said tube of the first plurality is operated it prepares for operation all the tubes of the group with which it is associated.

14. In combination, a product accumulator actuable by electric impulses; a multiplier unit including a plurality of electron discharge tubes, each of said tubes representing a denomination in the binary system of numerical notation; a multiplicand unit including a plurality of electron discharge tubes, each of said tubes representing a denomination in the binary system of numerical notation; a plurality of means for entering data into the several denominations of the accumulator; a plurality of electron tubes, each of which produces an electric impulse when actuated by operation of a tube of the multiplier unit in conjunction with the operation of a tube of the multiplicand unit at the same time; and means connecting one or more of the electric impulse producing tubes to an associated one of the data entering means so that when one of the tubes associated with the data entering means is caused to produce an impulse by reason of the associated multiplier and multiplicand tubes being actuated, data is entered into the proper denomination of the accumulator to represent the product of the value of said multiplicand tube as multiplied by the value of said multiplier tube.

15. In combination, an accumulator of data having denominational orders based on the binary numerical notation; a plurality of electron tubes equal in number to the number of denominations in a multiplier as multiplied by the number of denominations in a multiplicand; a multiplier unit based upon the binary system of numerical notation, said unit including a gaseous electron tube for each denomination of the multiplier, including means connecting the tubes so they may be caused to operate in sequence in response to commonly received electric impulses, including an output conductor for each tube having impressed thereon electric potential changes as the associated tube is rendered conducting, said output conductors having selecting means included therein to connect or disconnect the conductor with or from the associated tube; a multiplicand unit, including a plurality of electron discharge tubes connected so they are operated one at a time in sequence automatically, said multiplicand unit including an output conductor for each tube, which is impressed with an electric potential change as the associated tube is operated, including selective means whereby each output conductor may be connected with or disconnected from said associated multiplicand tube so as to determine whether a potential change shall be produced on said conductor, means to cause the sequence of operation to be repeated, said means also causing a step of operation of the multiplier unit, and means controlled by completion of operation of the multiplier unit for disabling the repeating means of the multiplicand unit; and means for operating the tubes of the first mentioned plurality of tubes under joint control of the combined output means of the multiplier unit and the multiplicand unit so as to operate a selected one of said tubes

When a certain one of the multiplicand unit output conductors receives a potential change at the same time a certain one of the output conductors of the multiplier unit receives a potential change, the operated tube of the first plurality having an output conductor leading to the proper denomination of the accumulator so as to enter therein the product data represented by multiplying the value of the associated multiplicand tube by the value of the associated multiplier tube.

16. In combination, an accumulator of numerical data based on the binary system of numerical notation, including denominational groups of electron tubes, the tubes representing the digits in the denomination, said accumulator being actuated by electric potential changes introduced thereto by denominational orders or between denominational orders; data introducing means consisting of a plurality of electrical conductors each representing a denomination of the accumulator corresponding to the product of a digit of a multidimensional number multiplier by a digit of a multidimensional number multiplicand; and means to apply a potential variation to any such conductor by having connected thereto an electrode of a thyratron connected in a self-extinguishing actuating circuit having a designated numerical value of the denomination of the accumulator represented by the conductor; and denominational digit representing multiplier selecting means and denominational digit representing multiplicand selecting means to control said thyratrons selectively whereby those thyratrons representing the product of the selected multiplier number by a selected multiplicand number are caused to become active in denominational sequence, thus giving the input conductors a potential change to enter product data into the accumulator.

17. In combination, a plurality of electronic relays having designated product values, said relays being selectively controlled jointly by a multiplier unit and a multiplicand unit, each unit being divided into denominations, each relay being associated with one denomination in each unit; means to issue potential variations from the multiplicand unit denomination by denomination and to impress them upon the associated ones of the relay devices to control them; means to issue potential variations from the multiplier unit denomination by denomination and impress them upon the associated ones of the relay devices, said multiplicand unit and multiplier unit potential variations being timed to act jointly at discrete periods to render the associated product designating relays effective to represent the associated product.

18. In a multiplying device wherein the multiplication is performed in stages each under control of a denomination of a multiplier, the combination of a plurality of groups of self-resetting electron discharge tube relays, each group representing a stage of multiplication and each tube in the group also representing a denomination of the multiplicand; a conductor for controlling each group controlled by a multiplier unit; a multiplicand unit and including a conductor for each denomination of the multiplicand, which conductors are coupled jointly with the conductors from the multiplier to the electron tubes for determining which of the relay tubes shall become conductive to represent product data.

19. In combination, a denominational accumu-

lator of numerical data based on the binary system of notation, actuated by electric impulses introduced into the several denominations; impulse-producing means for actuating the accumulator, including a plurality of electron tubes equal in number to the number of denominations of a multiplier times the number of denominations of a multiplicand, each of said tubes being supplied with operating energy and connected so as to supply an impulse to the proper denomination of the accumulator when acted upon conjointly by a digit-representing device of the multiplier and a digit-representing device of the multiplicand whose product such tube represents; an electronic multiplier unit based on the binary system of numerical notation, including a tube for each denominational order of the multiplier; a multiplicand unit based on the binary system of numerical notation, there being an electron tube for each denomination of the multiplicand; connections between the multiplier tubes and the impulse-producing tubes; connections between the multiplicand tubes and the impulse-producing tubes; and connections between the multiplier tubes and the multiplicand tubes whereby each tube of the multiplier unit is rendered conducting in conjunction with each tube in the multiplicand unit to control the corresponding tube of the impulse-producer.

20. In combination, a denominational accumulator of numerical data based on the binary system of notation, actuated by electric impulses introduced into the denominations; impulse producing means for actuating the accumulator, including a plurality of electron tubes equal in number to the number of denominations of a multiplier times the number of denominations of a multiplicand, each of said tubes being supplied with operating energy and connected so as to supply an impulse to the proper denomination of the accumulator when acted upon conjointly by a digit-representing device of the multiplier and a digit-representing device of the multiplicand, whose product such tube represents; an electronic multiplier unit, based on the binary system of numerical notation, including a tube for each denominational order of the multiplier; a multiplicand unit based on the binary system of numerical notation, including an electron tube for each denomination of the multiplicand; connections between the multiplier tubes and the impulse-producing tubes; connections between the multiplicand tubes and the impulse producing tubes; connections between the multiplier tubes and the multiplicand tubes whereby each tube in the multiplier unit is rendered conducting in conjunction with each tube in the multiplicand unit to conjointly affect the corresponding tube in the impulse-producer; and means for selecting which digit tubes of the multiplier unit and the multiplicand unit shall act conjointly.

21. In combination, a multiplier unit, including a gaseous electron discharge tube for each denomination of a multiplier based on the binary system of numerical notation, each of said tubes including an anode, a cathode, and a control electrode; means supplying operating energy to each of said tubes; means for applying a normally controlling potential on said control grids; means to connect the tubes so they are rendered conducting one at a time in sequence in response to electric impulses commonly received by all but the first tube applied to the control grids, the conductivity of a preceding tube of the sequence

priming the grid of the succeeding tube of the sequence so as to be responsive to the next impulse; means to cause conduction in the first tube of the sequence; means including a resistance in the cathode supply circuit for each tube for causing a potential rise in the cathode as a tube becomes conducting; means connected to said cathodes of all but the last tube receiving an electric impulse each time the associated tube is rendered conducting; a multiplicand unit, including a plurality of electron discharge tubes, each representing a denomination in the binary system of numerical notation, each of said tubes including an anode, a cathode and a control grid; means for applying operating energy to the anode-cathode circuits of said tube; means to apply a normally controlling bias to the grid of said tubes to prevent conduction therein; means connecting the tubes so they are caused to become conducting one at a time in sequence automatically; means to start conduction in the first tube of the sequence; means to recycle the multiplicand tubes so they may be caused to automatically repeat their operation in sequence, said recycling means impressing an impulse upon grids of all but the first of the tubes of the multiplier unit to cause a step of operation therein; means rendered effective at the completion of the sequential operation of the multiplier tubes to render the recycling means of the multiplicand tubes ineffective; means including a resistor in the cathode supply of each tube of the multiplier unit to cause a potential rise in the cathode as the tube becomes conducting; an output conductor connected with the cathode of each tube of the multiplicand unit except the last; a plurality of self-extinguishing gaseous triode electron discharge tubes, each of said self-extinguishing tubes representing the product of one of the digits of the multiplier by one of the digits of the multiplicand, and said number of self-extinguishing tubes equalling the product of the number of multiplier denominations by the number of multiplicand denominations; means normally supplying a controlling potential bias to said self-extinguishing tubes to prevent conduction there-

in; means connecting the output conductor for each denomination of the multiplier with the self-extinguishing tubes whose designated product includes that digit of the multiplier as a factor, whereby when said multiplier tube is in a conducting condition, the controlling bias upon the control grids of those corresponding self-extinguishing tubes is reduced; means connecting the output conductors of the multiplicand unit to those self-extinguishing tubes whose designated product includes that digit as a factor to give said tubes an impulse whereby to destroy the controlling bias on any associated tube which has had its potential reduced by connection to a conducting multiplier tube; a plurality of conductors, each representing a denomination of a binary numerical accumulator, all of the self-extinguishing tubes whose value is the value of the conductor being connected thereto and delivering thereto an electric impulse upon the discharge of any of said connected self-extinguishing tubes; an electronic product accumulator of numerical data based on the binary system of numerical notation, each denomination of which includes two electron discharge tubes connected for alternate operation so that an electric impulse impressed commonly thereon will cause the conducting tube of the denomination to become extinguished and the non-conducting tube of the denomination to become conducting; means connecting each conductor from the self-extinguishing tubes to the corresponding denomination tubes of the product accumulator so that when any impulse is received by said conductor it will change the mode of operation of the corresponding denominational tubes; and means interconnecting the denominations of the accumulator whereby when the denomination having had entered therein its full capacity of data receives another impulse from the associated self-extinguishing tubes, the denomination will return to zero and in so doing impresses an impulse on the next higher denomination so as to enter therein a unit of data.

JOSEPH R. DESCH.
ROBERT E. MUMMA.

Certificate of Correction

Patent No. 2,404,697.

July 23, 1946.

JOSEPH R. DESCH, ET AL.

It is hereby certified that error appears in the printed specification of the above numbered patent requiring correction as follows: Column 16, line 38, claim 11, for the word "cycling" read *recycling*; and that the said Letters Patent should be read with this correction therein that the same may conform to the record of the case in the Patent Office.

Signed and sealed this 22nd day of October, A. D. 1946.

[SEAL]

LESLIE FRAZER,

First Assistant Commissioner of Patents.