

T. E. WARREN.
 VACUUM STOCK THICKENING AND WASHING MACHINE.
 APPLICATION FILED JAN. 27, 1910.

1,002,017.

Patented Aug. 29, 1911.

4 SHEETS—SHEET 1.

Fig. 1.

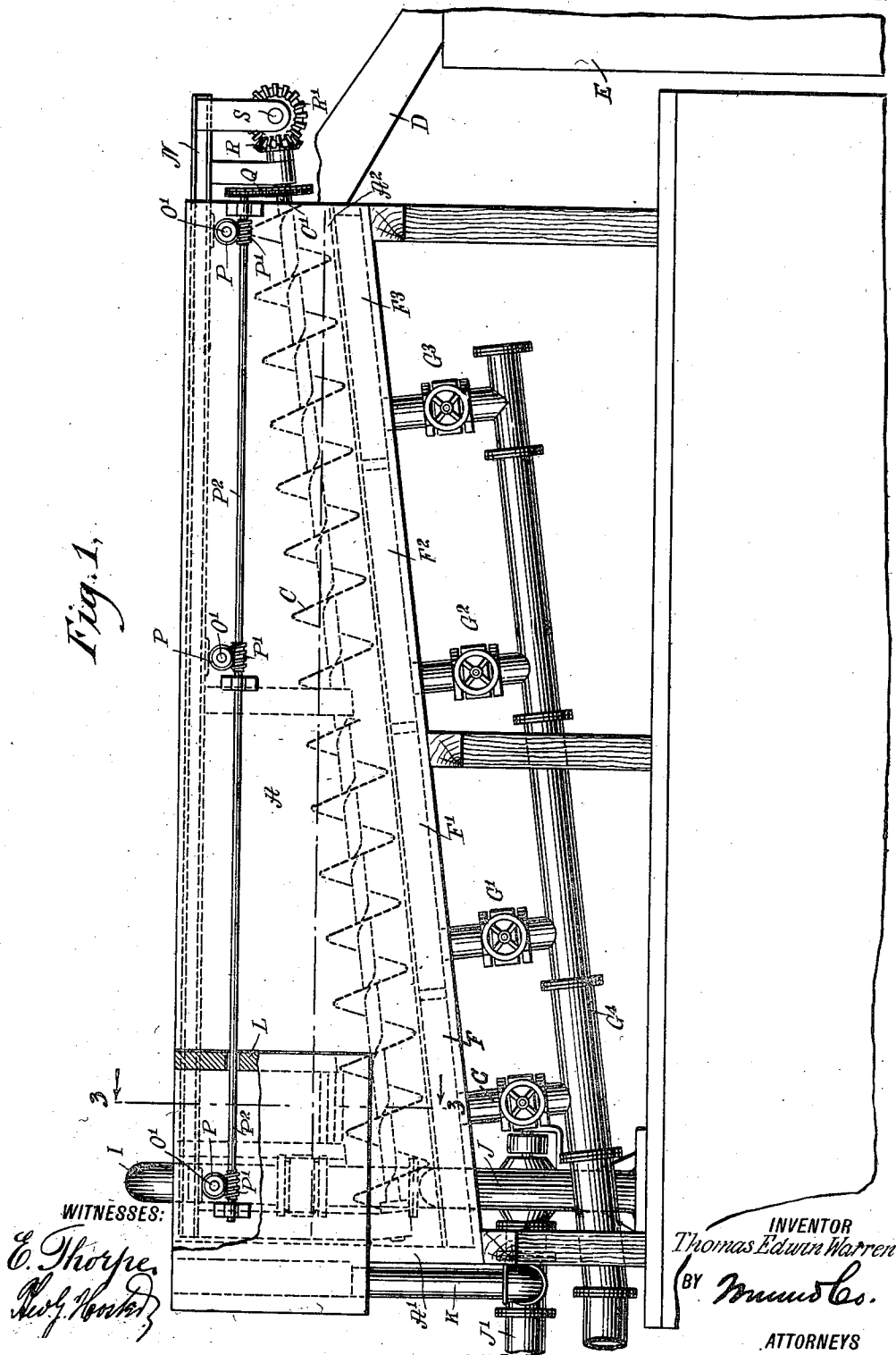

WITNESSES:

E. Thorpe
R. W. Woodard

INVENTOR
Thomas Edwin Warren
 BY *Munn & Co.*
 ATTORNEYS

T. E. WARREN.
 VACUUM STOCK THICKENING AND WASHING MACHINE.
 APPLICATION FILED JAN. 27, 1910.

1,002,017.

Patented Aug. 29, 1911.

4 SHEETS—SHEET 2.

Fig. 2.

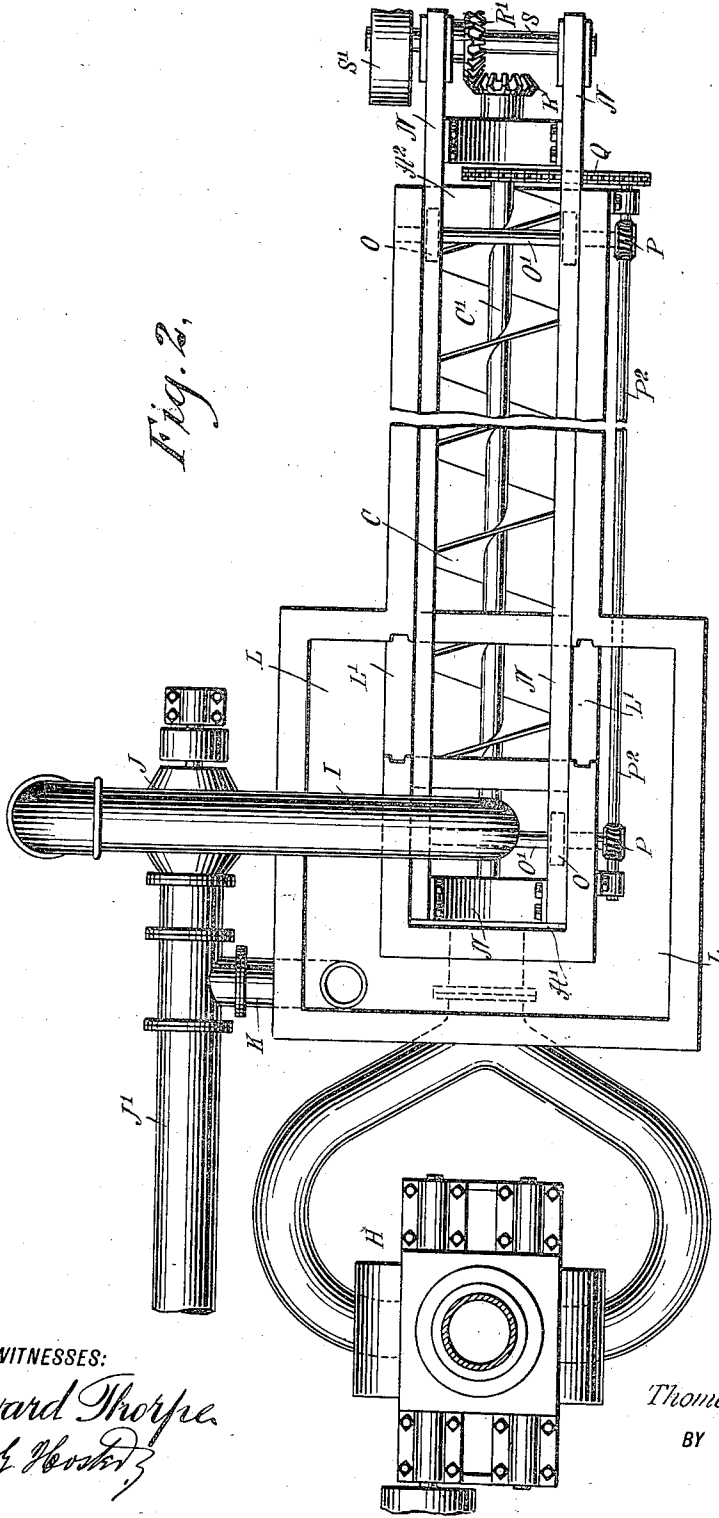

WITNESSES:
Edward Thorpe
Rudolf Herold

INVENTOR
Thomas Edward Warren
 BY *Munn Co.*
 ATTORNEYS

T. E. WARREN.
 VACUUM STOCK THICKENING AND WASHING MACHINE.
 APPLICATION FILED JAN. 27, 1910. Patented Aug. 29, 1911.
 1,002,017. 4 SHEETS—SHEET 3.

Fig. 3,

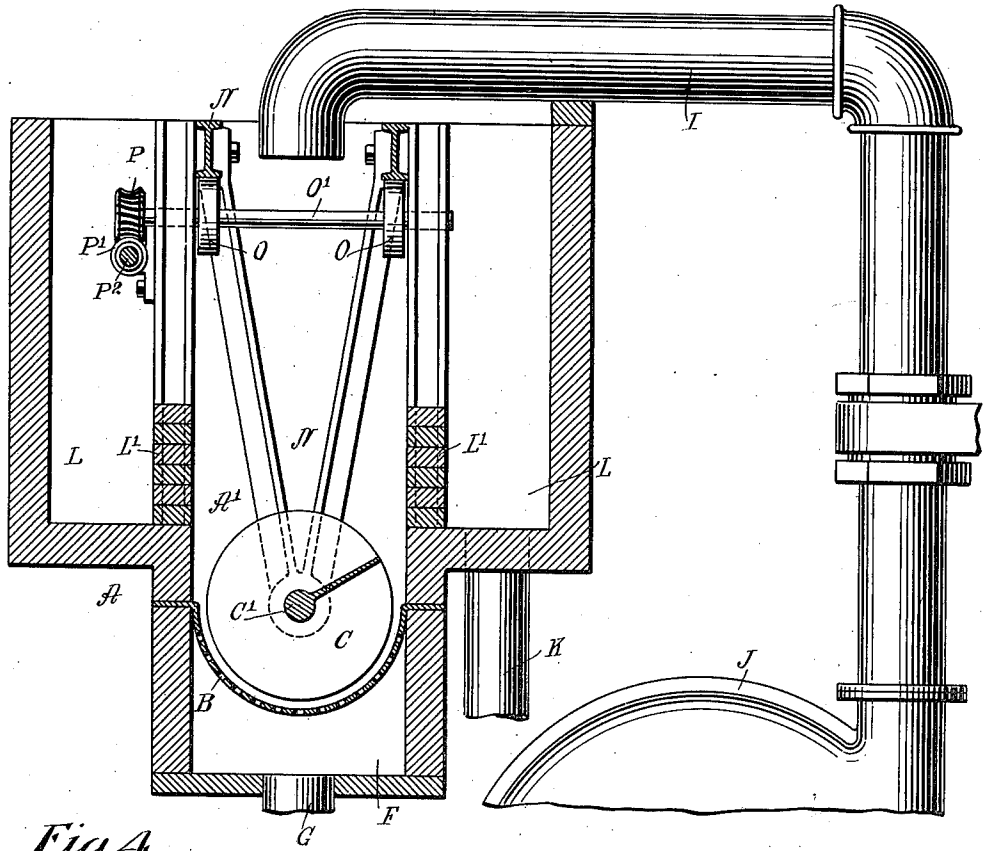
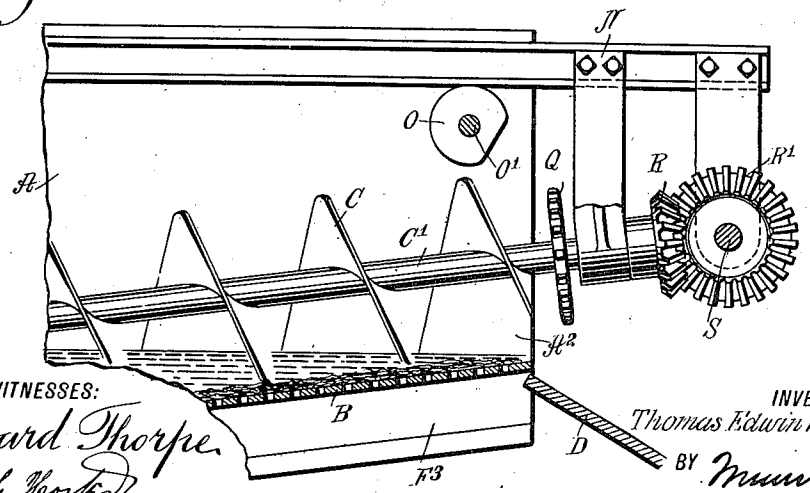

Fig. 4.



WITNESSES:
Edward Thorpe
Ruby Hooker

INVENTOR
Thomas Edwin Warren
 BY *Munn Co.*
 ATTORNEYS

T. E. WARREN.
 VACUUM STOCK THICKENING AND WASHING MACHINE.
 APPLICATION FILED JAN. 27, 1910. Patented Aug. 29, 1911.

4 SHEETS—SHEET 4.

Fig. 5.

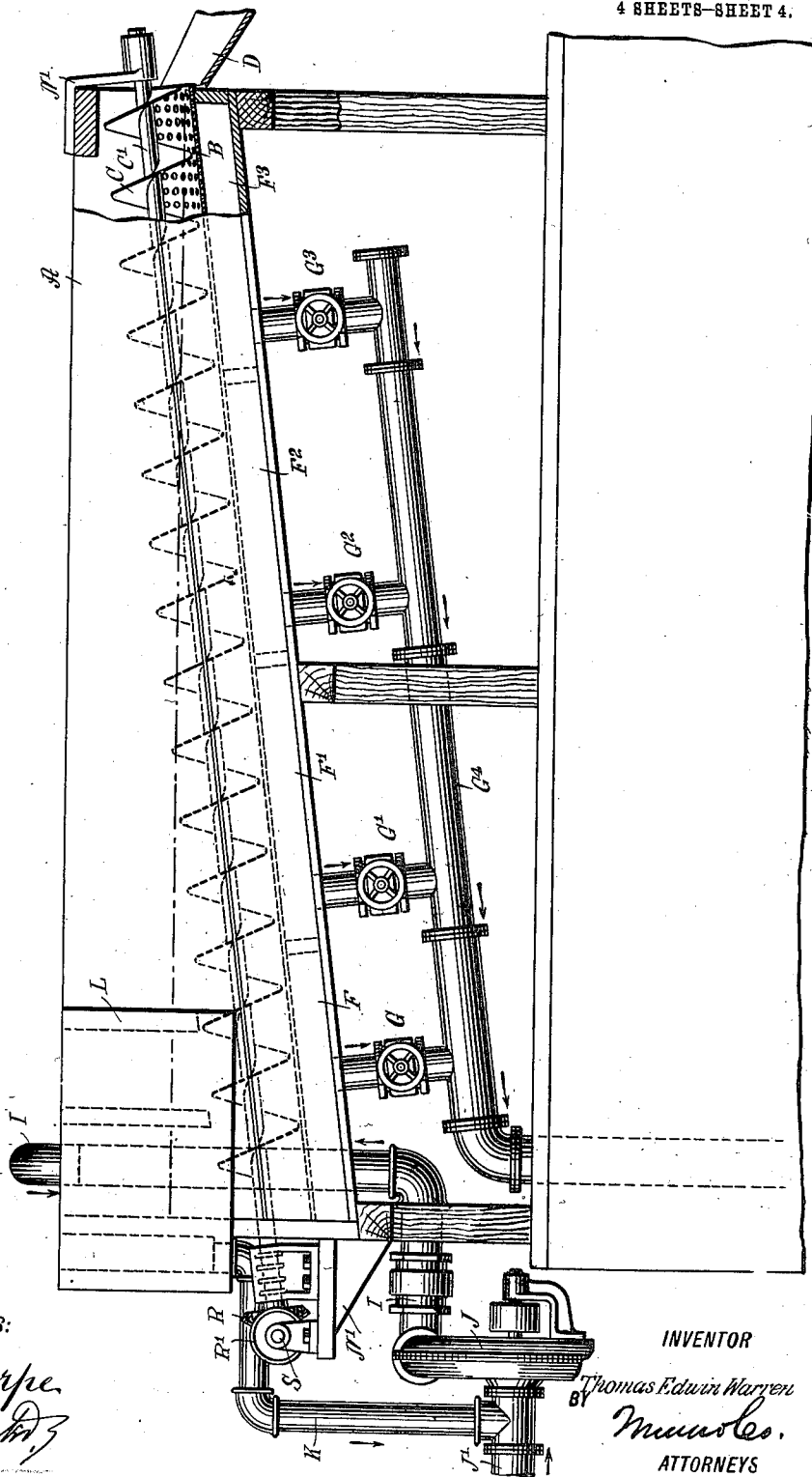

WITNESSES:
Edw. Thorpe
Henry Stewart

INVENTOR
Thomas Edwin Warren
 BY *Munn & Co.*
 ATTORNEYS

UNITED STATES PATENT OFFICE.

THOMAS EDWIN WARREN, OF TICONDEROGA, NEW YORK.

VACUUM STOCK THICKENING AND WASHING MACHINE.

1,002,017.

Specification of Letters Patent. Patented Aug. 29, 1911.

Application filed January 27, 1910. Serial No. 540,359.

To all whom it may concern:

Be it known that I, THOMAS EDWIN WARREN, a citizen of the United States, and a resident of Ticonderoga, in the county of Essex and State of New York, have invented a new and Improved Vacuum Stock Thickening and Washing Machine, of which the following is a full, clear, and exact description.

The invention relates to paper-making machinery, and its object is to provide a new and improved vacuum stock thickening and washing machine, arranged to separate water from fibrous material without the loss of the finer fibers and other minute particles, to produce a stock of uniform consistency and to permit convenient adjustment for producing a stock of a thicker or a thinner consistency, as desired, and according to the nature of the fibrous material to be treated. For the purpose mentioned use is made of mechanical means, whereby the fibrous material contained in a vessel is utilized as its own filtering medium.

A practical embodiment of the invention is represented in the accompanying drawings forming a part of this specification, in which similar characters of reference indicate corresponding parts in all the views.

Figure 1 is a side elevation of the machine, part being in section; Fig. 2 is an enlarged plan view of the same; Fig. 3 is an enlarged cross section of the same on the line 3-3 of Fig. 1; Fig. 4 is an enlarged sectional side elevation of the discharge end of the machine; and Fig. 5 is a side elevation of a modified form of the machine.

A stationary vessel A for receiving the fibrous material to be treated is provided with a perforated bottom B, preferably inclined, as shown in the drawings, and over which is arranged a conveyer C following the bottom B, and extending upwardly and rearwardly from the stock supply end A' to the rear open or discharge end A², over which the stock is discharged from the vessel A into a chute D, delivering the stock to a stock tank E for further treatment. Below the perforate bottom B are arranged a series of suction chambers F, F', F², F³, connected by valved suction pipes G, G', G², G³ with a graduated pipe G⁴, connected with the suction end of a suction device H, in the form of a suction pump or the like, so that

when the suction device H is in action, a suction action is produced in the several suction chambers F, F', F² and F³, and this suction is graduated by arranging the valves of the suction pipes G, G', G², G³ correspondingly. The fibrous material to be treated is discharged into the lower end A' of the vessel A by a pipe I, connected with a pump J, of any approved construction, preferably, however, a rotary pump, having its suction pipe J' connected with a fibrous material supply. An overflow pipe K connects with the suction pipe J' of the pump J, and leads to the bottom of an overflow box L, extending from the lower end A' of the vessel A, as plainly indicated in the drawings. The overflow box L is provided on opposite sides with overflow gates L', connecting the lower end of the vessel A with the said box L, and the said gates L' are made in sections, to permit of increasing or decreasing heights of the gates, so as to correspondingly raise or lower the level of the fibrous material in the vessel A. Now the overflow from the vessel A into the box L is conducted by the pipe K into the suction pipe J', so as to be returned by the pump J and the pipe I into the vessel A.

The shaft C' of the conveyer C is journaled in bearings carried by a frame N, supported on cams O, arranged in pairs secured on transverse shafts O', journaled in the sides of the vessel A, and on one outer end of each shaft O' is secured a worm wheel P in mesh with a worm P', secured on a longitudinally-extending shaft P², journaled in suitable bearings arranged on the outside of the vessel A. The rear end of the shaft P² is connected by sprocket wheels and chain Q with the conveyer shaft C, so that when the latter is rotated, a rotary motion is transmitted by the said sprocket wheels and chain Q to the shaft P², which by the worms P' and the worm wheels P rotates the shafts O' simultaneously, thus causing the cams O to alternately raise and lower the frame N with it the conveyer C, so that the spiral blades thereof come alternately in close contact with the perforate bottom B and out of contact with the same when raised.

The rear end of the conveyer shaft C' is provided with a bevel gear wheel R, in mesh with a bevel gear wheel R', secured on a driving shaft S, journaled in the frame N

and connected by a pulley S' and belt with other machinery, for imparting a continuous rotary motion to the shaft S. Thus when the shaft S is rotated a rotary motion is transmitted to the conveyer C and at the same time a slow up and down movement is given to the conveyer by the mechanism above described.

The operation is as follows: When the machine is running and the fibrous material to be treated is pumped by the pump J and the pipe I into the vessel A, then the latter is filled to a predetermined level, according to the overflow gates L', as previously mentioned. As indicated in Fig. 1, the level of the fibrous material contained in the vessel A extends to the bottom of the outlet A², so that a portion of the screw conveyer C is not wholly submerged in the fibrous material. Now as the screw conveyer C is rotated it moves the fibrous material toward the discharge end A², and as a suction is produced in the bottom of the bulk of fibrous material by the action of the suction device H, pipes G⁴, G, G', G², G³, suction chambers F, F', F², and F³ and the perforations in the bottom B, it is evident that a layer of fibers is formed over the bottom B, and this layer acts as a filtering medium, through which the water from the fibrous material is drawn by the suction action above referred to. It will be noticed that the fibrous material is gradually thickened as it is moved by the conveyer C toward the discharge end A², as water is continually removed from the fibrous material by the suction action mentioned, and consequently the pipes G, G', G², G³ are graduated, that is, the pipe G is required to draw off a larger amount of water than the pipe G', the latter draws more water than the pipe G², and the latter more water than the pipe G³. It will also be noticed that as the screw conveyer C is intermittently raised and lowered, the bottoms of the conveyer blades come in contact with the filtering layer of fibers and move the same upward along the bottom B, to make room for other fibers to form a new filtering medium and to prevent the old filtering medium from becoming too dense, thus preventing or frustrating a proper suction action.

Although it is preferred to intermittently move the conveyer C up and down as described, its shaft C' may be journaled in stationary bearings N' attached to the vessel A, as indicated in Fig. 5. In this case the bottom of the conveyer C is a short distance from the perforate bottom B so as to allow the formation of a layer of fibers over the bottom as a filtering medium. Otherwise the construction of the machine is practically the same as above described, so that further description is not deemed necessary. It is understood that in both cases, however,

the bottom B is semicircular in cross section, as plainly indicated in Fig. 3, and the conveyer C when in its lowermost position is approximately concentric with the said bottom.

From the foregoing it will be seen that by the arrangement described, the water contained in the fibrous material is gradually withdrawn, so as to thicken the stock and to wash the same, the stock finally discharged in the chute D being of uniform consistency. By raising or lowering the level of the fibrous material in the vessel A, the process of thickening and washing can be hastened or retarded, to produce thicker or thinner stock as desired, and according to the nature of the fibrous material under treatment at the time.

Although I have shown and described preferred forms of the machine, it is evident that the construction of the machine may be varied, and the vessel A, bottom B and conveyer C may be arranged horizontally instead of inclined, and other forms of conveyers, such as chain conveyers having bottom scrapers, may be employed to move the stock in one direction in the vessel and to periodically dislodge the layer of fibers used as a filtering medium, to allow the formation of a new layer of filtering material by a suction action.

Having thus described my invention, I claim as new and desire to secure by Letters Patent:

1. A vacuum stock thickening and washing machine, comprising a vessel having a perforate bottom, a conveyer in the said vessel for moving the fibrous material in one direction in the said vessel, and a series of graduated suction devices underneath the said perforate bottom.

2. A vacuum stock thickening and washing machine, comprising a vessel having a perforate bottom and an open discharge end, a conveyer in the said vessel for moving the fibrous material toward the said open end, a plurality of suction chambers underneath the said perforate bottom, and valved suction pipes connected with the said suction chambers.

3. A vacuum stock thickening and washing machine, comprising a vessel, provided at one end with a stock discharge and at the other end with a stock supply and an adjustable overflow, the vessel having a perforate bottom, a conveyer in the said vessel for moving the stock toward the discharge end, and a suction device connected with the vessel below the perforate bottom.

4. A vacuum stock thickening and washing machine, comprising an inclosed vessel open at the upper or discharge end, and provided with a perforate bottom, means for supplying the material to the lower or supply end of the same, an overflow receptacle

at the supply end of the vessel, a connection between the overflow receptacle and the supplying means, a series of suction chambers underneath the said bottom, graduated suction pipes connected with the said suction chambers, and a conveying device for moving the stock in the vessel toward the said discharge end.

5. A vacuum stock thickening and washing machine, comprising an inclined vessel open at the upper or discharge end, and provided with a perforate bottom, a supply pipe discharging into the lower or supply end of the vessel, a pump with which the supply pipe is connected, a series of suction chambers underneath the said bottom, graduated suction pipes connected with the said suction chambers, a conveying device for moving the stock in the vessel toward the said discharge end, an overflow receptacle at the lower end or supply end of the vessel, and a pipe leading from the said receptacle to the suction pipe of the pump.

6. A vacuum stock thickening and washing machine, comprising an inclined vessel open at the upper or discharge end, and provided with a perforate bottom, a supply pipe discharging into the lower or supply end of the vessel, a series of suction chambers underneath the said bottom, graduated suction pipes connected with the said suction chambers, a conveying device for moving the stock in the vessel toward the said discharge end, and an adjustable overflow at the lower or supply end of the vessel for raising or lowering the level of the stock in the vessel.

7. A vacuum stock thickening and washing machine, comprising an inclosed vessel open at the upper or discharge end and provided with a perforate bottom, a supply pipe discharging into the lower or supply end of the vessel, a series of suction chambers underneath the said bottom, graduated suction pipes connected with the said suction chambers, a conveying device for moving the stock in the vessel toward the said discharge end, and means for alternately raising or lowering the said conveying device.

8. A vacuum stock thickening and washing machine, comprising an inclined vessel open at the upper or discharge end and provided with a perforate bottom, a supply pipe discharging into the lower or supply end of the vessel, a series of suction chambers underneath said bottom, graduated suction pipes connected with the said suction chambers, an inclined screw conveyer in the said vessel for moving the fibrous material toward the said discharge end, and means for alternately raising and lowering the said screw conveyer, to intermittently engage the layer of fibers on the said perforate bottom, to

move the layer toward the said discharge end.

9. In a vacuum stock thickening and washing machine, an inclined vessel having a discharge at its upper end and provided with a perforated bottom, a conveyer in the vessel, a frame in which the conveyer is mounted, cams on which the frame is supported, a shaft geared with the cams, and means for operating said shaft from the conveyer.

10. In a vacuum stock thickening and washing machine, an inclined vessel having a discharge at its upper end, and provided with a perforated bottom, a screw conveyer in the vessel, a frame in which the conveyer is mounted, a plurality of cams on which the frame is supported, the shafts of the cams being provided with worm wheels, a longitudinal shaft having worms engaging the worm wheels, and gearing between the said shaft and the conveyer shaft.

11. In a vacuum stock thickening and washing machine, an inclined vessel having a discharge at its upper end and provided with a perforated bottom, a conveyer in the vessel for moving the stock toward the discharge end, a pump for discharging the stock into the lower end of the vessel, an overflow box, and an overflow pipe leading from the bottom of the box to the suction pipe of the said pump.

12. The herein described method for thickening and washing fibrous material in bulk, consisting in forming a layer of fibers in the bottom of the bulk, and subjecting the said layer to a suction action to filter the water of the fibrous material through the said fiber layer, the latter acting as the filtering medium.

13. The herein described method for thickening and washing fibrous material in bulk in a vessel, consisting in subjecting the bottom of the bulk to a suction action to produce a layer of fibers through which the water in the fibrous material is filtered by the suction action.

14. The herein described method for thickening and washing fibrous material in bulk in a vessel, consisting in subjecting the bottom of the bulk to a suction action to produce a layer of fibers through which the water in the fibrous material is filtered by the suction action, and intermittently moving the said layer to form a fresh filtering layer.

In testimony whereof I have signed my name to this specification in the presence of two subscribing witnesses.

THOMAS EDWIN WARREN.

Witnesses:

EDWARD C. D. WILEY,
I. C. NEWTON.