

No. 834,293.

PATENTED OCT. 30, 1906.

V. J. GILLETT.  
FOLDING BED.

APPLICATION FILED NOV. 7, 1904.

2 SHEETS—SHEET 1.

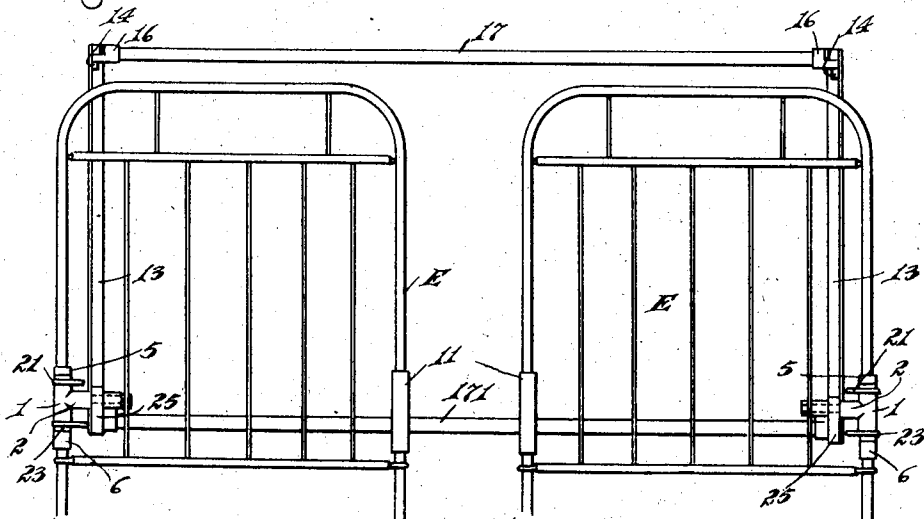
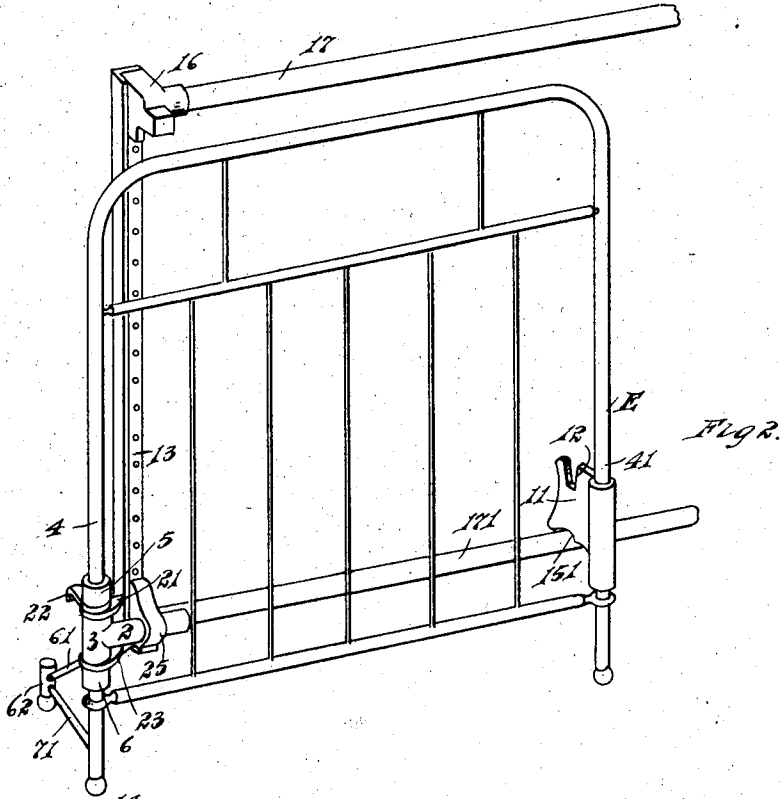

WITNESSES

T. J. Marsey  
W. L. Day.

Fig. 1.

INVENTOR

Vernor J. Gillett

By

Parker & Bunton Attorneys.

No. 834,293.

PATENTED OCT. 30, 1906.

V. J. GILLETT.  
FOLDING BED.

APPLICATION FILED NOV. 7, 1904.

2 SHEETS—SHEET 2.

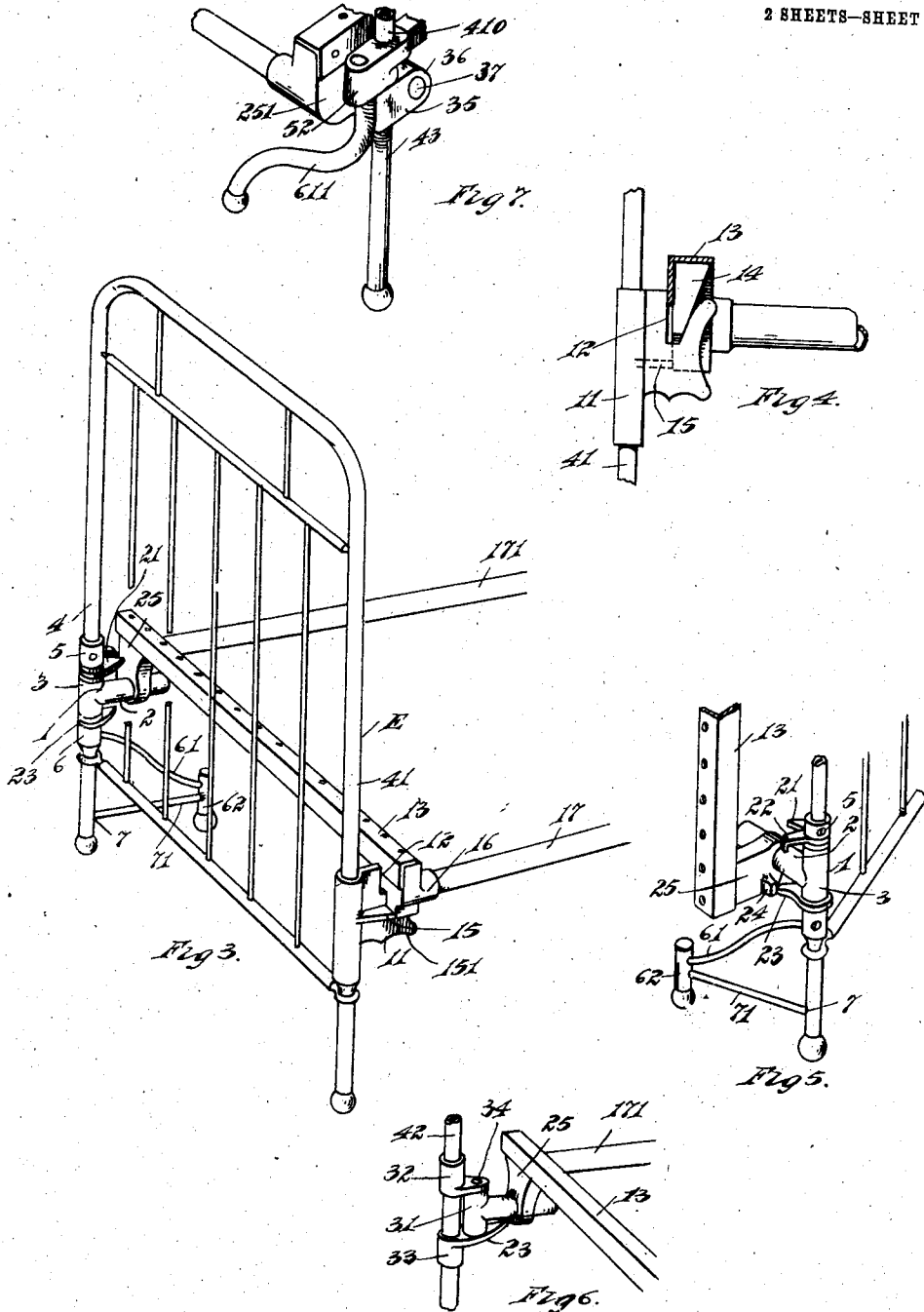

WITNESSES  
*T. F. Massey*  
*C. F. Day*

INVENTOR  
*Vernor J. Gillett*  
 By  
*Parker & Burton* Attorneys.

# UNITED STATES PATENT OFFICE.

VERNOR J. GILLET, OF DETROIT, MICHIGAN.

## FOLDING BED.

No. 834,293.

Specification of Letters Patent.

Patented Oct. 30, 1906.

Application filed November 7, 1904. Serial No. 231,698.

*To all whom it may concern:*

Be it known that I, VERNOR J. GILLET, a citizen of the United States, residing at Detroit, county of Wayne, State of Michigan, have invented a certain new and useful Improvement in Folding Beds; and I declare the following to be a full, clear, and exact description of the invention, such as will enable others skilled in the art to which it pertains to make and use the same, reference being had to the accompanying drawings, which form a part of this specification.

This invention relates to folding beds, and has for its object an improved folding bed that folds into small compass, is neat in appearance in its folded form, and in its unfolded or extended form when in use for sleeping purposes is firm and stable.

In the drawings, Figure 1 is a side elevation of the bed in its folded condition. Fig. 2 shows, on a larger scale and in perspective, one end of the end frame folded against the bottom. Fig. 3 shows in perspective one end of the bed-frame and the bottom turned down to the position it occupies when in use for sleeping purposes. Fig. 4 is a detail drawing of a front connection. Fig. 5 is a detail drawing of the rear foot of the end frame. Fig. 6 shows a modified hinge connection between the end frame and the bed-bottom. Fig. 7 shows a modified hinge connection.

The end frame E is provided at the front with a bracket 11, on which the bottom rests, and at the back with the coupling 1, by which it is coupled to the bottom.

The coupling 1 is provided with a branch 2, which in use extends horizontally and serves as a pivot upon which the mattress-supporting frame (hereinafter called the "bed-bottom") swings. It is provided with a cross-head 3, which in use is arranged vertically and which is tubular to receive the post 4 at one side of the part technically called the "head-board" or "footboard" of the bed, (hereinafter called "end frame.")

The post 4 of the end frame extends vertically through the coupling and turns therein. It is partly held in place with respect to the coupling by a collar 5, that is above the tubular part 3 of the coupling, and it is partly held in place by a collar 6. That is below the tubular part 3 of the coupling. Still lower on the post 4 is a hole 7, which supports one arm 71 of a bracket, of which the second arm 61 is se-

cured to collar 6. The two arms extend to a terminal 62, provided with a caster. The post itself is provided with a terminal caster, and the post 41 at the front is provided with a terminal caster. The post 41 has sleeved on it and secured to it a bracket 11, provided on its upper side with a notch 12 to receive a cross-bar 13 and a fillet-bar 14, that is secured to the cross-bar 13 of the bed-bottom. The notch 12 is angular, and below the notch is an abutment-block 15, extending as a bracket from the main bracket 11. The end of the coupling 16 that unites the cross-bar 13 and the side bar 17 of the bed-bottom frame engages against this abutment and locks the parts firmly together.

The entire construction furnishes a three-point bearing between the bracket 11 and its subordinate bracket 15 and the parts which comprise this corner of the bed-bottom and furnishes a very secure and firm locking connection between the end board and the mattress-supporting frame. The points of contact or bearing-point are at the point of a triangle, of which one side is a nearly vertical line, and the meeting-point of the opposite side is about midway (vertically) between the upper and lower points at the terminals of said line. The bottom edge of the bracket 15 is curved and concave at 151 to enable it to engage over the side bar 171 of the bottom when the end frame is swung to the closed or folded position of the bedstead. When the bottom is turned down, the side bar 171 is farther from the middle line of the bed than the pivot 2, and as the bed-bottom is turned up on the pivot the side bar 171 swings to a position somewhat below the pivot 2 and somewhat below the position that it occupies when in the unfolded position of the bed and into a position in which the curved under surface of the bracket 11 can easily and readily engage over the bar 171, as is indicated in Fig. 2; but in order that it may engage over it must lift the post 41 enough to swing the caster at the bottom end of said post clear from the floor. The bracket from the collars 6 and 7 on the post 4 is at right angles to the general plane of the end frame, and when the end frame is swung to bring the bracket 11 into engagement with the bar 171, the bracket at the bottom end of the post 4 swings across under the now upturned bed-bottom, and this end of the bed-frame comes

to rest on the casters, which are underneath this bracket and underneath the end of the post 4.

5 The bed-bottom is provided at the rear with hanging-brackets 25, that are provided with a perforation to engage over the branches 2 of the coupling, and the parts are held together by any approved securing means.

10 A lug 21, fixed with respect to the coupling 1, engages with the curved lug 22, that is fixed with respect to the collar 5 when the end board is swung to its open position, as is indicated in Fig. 3, and a lug 23, fixed with respect to the coupling 1, engages a lug or projection 24 on the hanging-bracket 25 of the bed-bottom and stops the swinging of the mattress-supporting frame that has been turned to its upright or vertical position.

20 In Figs. 6 and 7 are shown modifications of the joint connection between the end frame and the bed-bottom. In the form shown in Fig. 6 the vertical post 42, instead of passing through the cross-head 31 of the coupling passes at one side of the cross-head through collars 32 and 33, which are secured to the vertical post. Each collar is provided with an ear, and the ears are perforated, and through the perforations and through the cross-head 31 is passed a pintle-bolt 34, which constitutes the connection between the coupling and the vertical post of the end frame. In the form shown in Fig. 7 the vertical post 43 terminates with a coupling 35, which has a bracket extension 36, provided with a horizontal hole for the pin 37, by means of which the hinge connection between the coupling and the bracket 251 of the bed-bottom is made. The coupling supports on a collar 52 at the lower end of the side post 410 of the swinging end frame. From the coupling 52 hangs a curved flange

611, that turns with the end frame. The vertical part of the flange 611 swings clear of the coupling 35.

What I claim is—

1. In a folding bed, in combination with a vertically-pivoted end frame, a coupling provided with a horizontal pivot engaging in said end frame pivotally, a bed-bottom engaging said horizontal pivot, and a bracket extending from the lower end of a corner-post and rigid with respect thereto at right angles to the plane of the end frame, adapted to form a support for the bed when in its folded condition, substantially as described. 50 55

2. In a folding bed, in combination with a coupling, an end frame vertically pivoted thereto, said end frame carrying a bracket capable of swinging at right angles to the plane of the end frame while maintaining such angularity therewith, a bed-bottom horizontally pivoted to said coupling, and means for inclining the weight of the bed upon said bracket, substantially as described. 60 65

3. In a folding bed, in combination with a horizontally-pivoted bed-bottom, a vertically-pivoted end frame provided with a bracket extending at right angles to the main plane of the end frame and adapted to swing while maintaining such right angle with the end frame, and means for lifting and supporting the front post of the end frame and thereby throwing the weight onto the rear post and said bracket, substantially as described. 70 75

In testimony whereof I sign this specification in the presence of two witnesses.

VERNOR J. GILLET.

Witnesses:

CHARLES F. BURTON,  
MAY E. KOTT.