

Jan. 27, 1959

P. ANGST ET AL
RAZOR HAVING AN ELASTIC RECIPROCATING CUTTING
MEANS TO CUT LONG AND SHORT HAIR

2,870,534

Filed Jan. 27, 1956

2 Sheets-Sheet 1

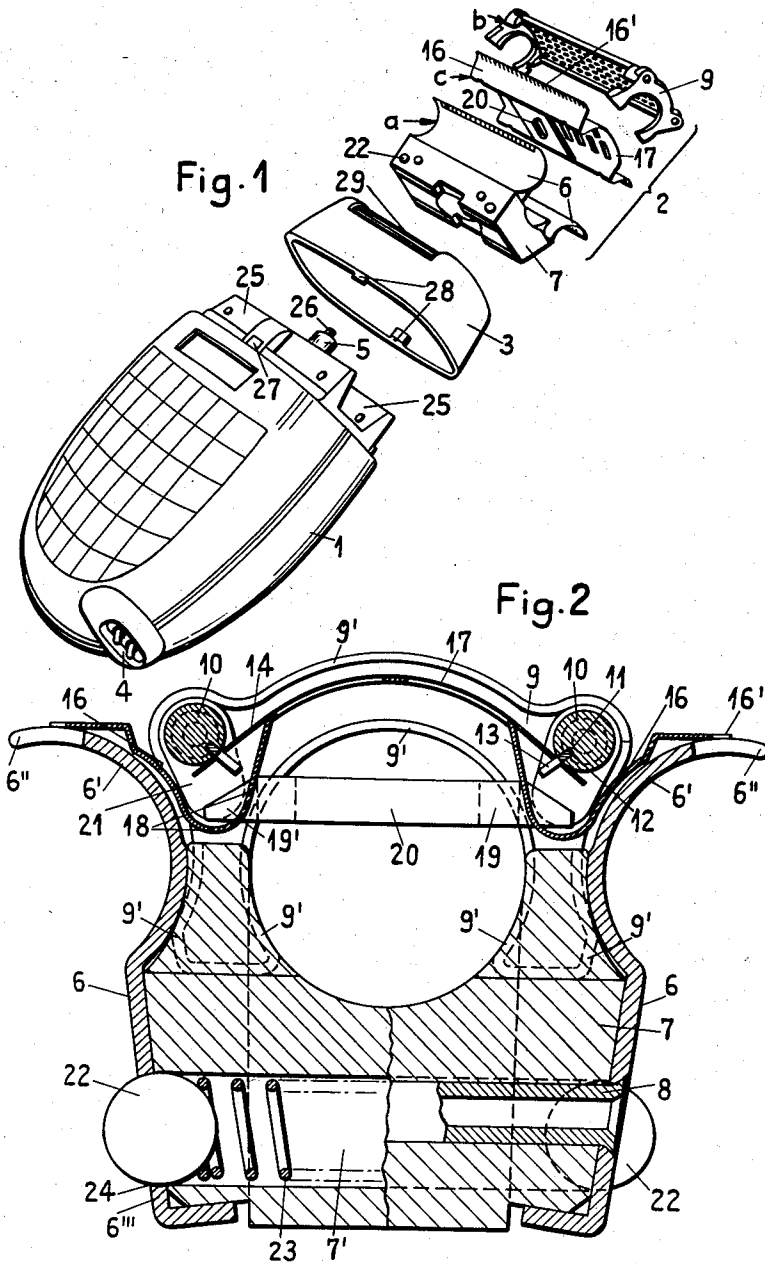

Jan. 27, 1959

P. ANGST ET AL
RAZOR HAVING AN ELASTIC RECIPROCATING CUTTING
MEANS TO CUT LONG AND SHORT HAIR

2,870,534

Filed Jan. 27, 1956

2 Sheets-Sheet 2

Fig. 3

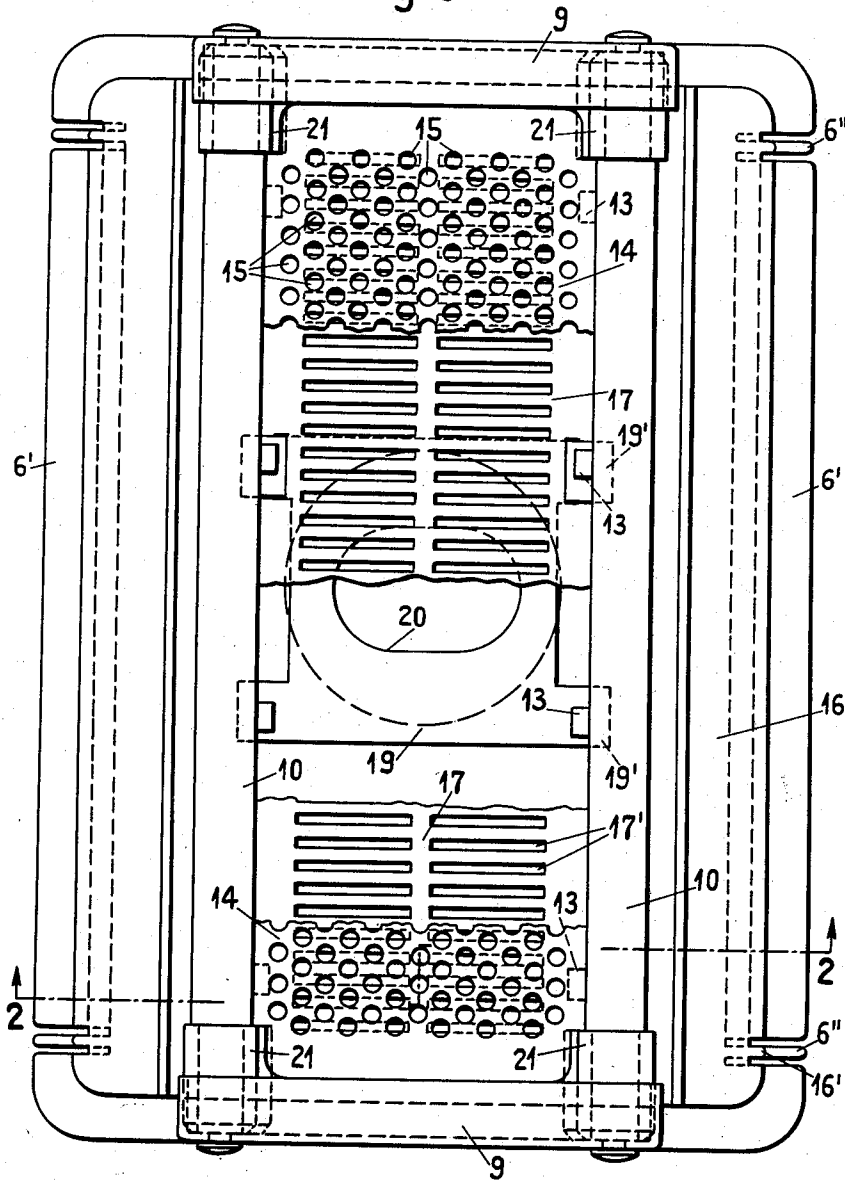

1

2,870,534

RAZOR HAVING AN ELASTIC RECIPROCATING CUTTING MEANS TO CUT LONG AND SHORT HAIR

Paul Angst and Willy Rabald, Uetikon am Albis, Switzerland

Application January 27, 1956, Serial No. 561,879

Claims priority, application Switzerland March 18, 1955

4 Claims. (Cl. 30—34)

The present invention relates to a hair cutting and shaving apparatus. It is the object of the present invention to provide a compact apparatus of simple design capable of use for the dual purpose as a hair cutter and as a dry razor, such apparatus being capable of easy cleaning and economical manufacture.

More particularly, it is an object of the present invention to provide a hair cutting and shaving apparatus having sets of open shearing combs on both sides well adapted to grip and cut hairs of substantial length and having a central dry razor system formed by a stationary perforated skin guard metal foil and by a reciprocating cutting comb in direct contact therebeneath, such central dry razor system following the set of open shearing combs provided on the leading edge of the apparatus to thereby shave the skin from which the hair has been cut previously by the open shearing combs.

According to the present invention, the novel hair cutting and shaving apparatus comprises a pair of substantially parallel combs fixed to a holder and having curved cross-sectional profiles with opposite concave faces and with teeth pointing in opposite directions, an elastic reciprocating cutting comb extending between and guided lengthwise of and contacting the parallel combs and having opposite toothed longitudinal marginal portions overlying the teeth of the parallel combs for hair cutting action and being reciprocated by driving means mounted in the holder and having a central curved portion provided with cutting slots, and a perforated skin guard metal foil which overlies the central portion of the reciprocating cutting comb and is held in stationary relationship to the parallel combs in contact with and biased against the central curved portion of the reciprocating cutting comb for shaving action.

Further objects of the present invention will appear from a detailed description of a preferred embodiment thereof following hereinafter, it being understood that the terms used in such detailed description have been chosen for the purpose of explaining the invention rather than that of restricting or limiting the same. In the drawings

Fig. 1 is a perspective exploded view of the novel hair cutting and shaving apparatus;

Fig. 2 is a section of the cutter head taken substantially along the broken line 2—2 of Fig. 3, viewed in the direction of the arrows inserted in Fig. 3, and

Fig. 3 is a plan view of the cutter head, the skin guard and the reciprocating cutting comb being partly shown broken away to expose the elements therebeneath to view.

As will appear from Fig. 1, the apparatus comprises a holder 1, a composite cutter head 2, and an intermediate socket 3. The holder 1 encases an electrical motor or spring-actuated motor including a shaft 5 having an eccentric stud 26, the end of such shaft projecting out of the end face of the holder 1. A channel member having a pair of spaced parallel arms 25 is

2

fixed to the end face of the holder 1 and adapted to engage the socket 3 when the same is placed on the holder. The arms 25 of the channel member have external centrally provided recesses 27 adapted to be resiliently engaged by internal detent teeth 28 provided near the lower edge of the socket 3 to thereby keep the same in position on the holder 1. The socket is open at the top for insertion of the cutter head 2 and is provided with bearings for a pair of spaced knurled rollers 29 serving the purpose of engaging and tensioning the skin from which the hair is to be cut.

The cutter head 2 which is adapted to be inserted in the socket 3 so that its top portion only projects therefrom is composed of three main parts *a*, *b* and *c*.

The lower part *a* of the cutter head comprises a pair of substantially parallel symmetrical combs 6, 6 which have curved cross-sectional profiles with opposite concave faces, as shown at 6', and are thus adapted to accommodate the rollers 29 when the part *a* is inserted in the socket 3. The teeth 6'' of the combs 6, 6 extend outwardly and point in opposite directions, only some of such teeth being shown in Fig. 3. The combs 6, 6 are attached to opposite sides of a spacer block 7 by means of a pair of rivets 8 which extend transversely through the spacer block 7, only one of the rivets being shown at the right of Fig. 2. For the purpose of fixing the cutter head including the part *a* thereof to the holder 1, the lower part *a* of the cutter head is provided with suitable detent means formed by two pairs of balls 22, each pair being mounted in a transverse bore 7' of the spacer block 7 and being urged in outward direction by an interposed spring 23 tending to keep the balls seated on the edges of holes 24 which are provided in the plane lower sections of the combs 6, 6 and register with the bore 7', the diameter of such holes being somewhat smaller than the diameter of the balls 22 to thereby retain the balls. When the cutter head 2 is being inserted in the socket 3 after the same has been placed on the holder 1, the balls 22 will be engaged and pressed inwardly by the arms of the channel member 25 which will straddle the member *a* engaging the sections 6''' of the combs 6, 6 thereof. When the cutter head arrives in inserted position in the socket 3, the balls 22 will engage registering recesses provided on the inside of the arms of the channel member 25 to thereby resiliently secure part *a* and the combs 6, 6 forming part thereof to the holder 1.

The elastic reciprocating cutting comb *c* extends between and is guided lengthwise of the combs 6, 6 and contacts the same. The elastic cutting comb has opposite toothed longitudinal marginal portions 16' which are preferably located in a common plane, as shown in Fig. 2, and overlie the teeth 6'' of the fixed combs 6, 6 to cooperate therewith for hair cutting action. Moreover, the elastic cutting comb which is preferably formed by an integral substantially rectangular blade of sheet steel has a central curved portion 17 provided with transverse cutting slots 17', shown in Fig. 3. Adjoining the central curved portion 17 are channel portions 18 which project downwardly into the space located between the curved portions 6' of the fixed combs 6, 6 and have outer portions 16 adjoining the toothed marginal portions 16'. Preferably, the portions 16 of the elastic cutting comb extend in close proximity to the curved portions 6' of the fixed combs. Preferably, the elastic cutting comb includes a transverse member 19 which has ends 19' engaging suitable apertures provided in the channel portions 18 of the sheet steel blade. This transverse member 19 is positioned intermediate the central curved portion 17 and the actuating shaft 5 and has a slot 20 extending lengthwise of the member 19 and being adapted,

when the parts are assembled, to be engaged by the eccentric stud 26 of the shaft 5 for reciprocation of the cutting comb.

The part *b* of the cutter head is a skin guard formed by a perforated metal foil 14 which overlies the central portion 17 of the elastic cutting comb and by suitable means is held in stationary relationship thereto and in contact with and biased against the central curved portion 17 cooperating therewith for shaving action. In the embodiment shown, the means for holding the foil comprises a pair of substantially parallel yoke members 9 and a pair of pins 10 connected with and extending between the yoke members 9 keeping the same in spaced relationship. Each yoke member 9 is formed by a thin sheet metal piece having a reinforcing flange 9' on its inside. The pins 10 are preferably riveted at their ends to the yoke members 9. The latter are horseshoe shaped for resilient engagement of their arms between the parallel combs 6, as will appear from Fig. 2. Each pin 10 is provided with a longitudinal groove 11 in which a key 12 formed by a strip of sheet metal is inserted. The key 12 has inwardly and downwardly extending teeth 13 engaging suitable perforations of the perforated metal foil 14 to thereby keep the same taut and biased against the central curved portion 17 of the cutting comb.

Preferably, arms 21 are mounted on the pins 10 near the ends thereof inside the yoke members 9 and are secured against relative rotation thereon by engagement with the keys 12. The arms 21 extend into the channel portions 18 of the cutting comb slidably engaging the same on both sides of the central portion 17 to thereby guide the steel blade of the cutting comb during the reciprocation thereof. To minimize friction, the arms 21 are preferably made of a suitable plastic, such as nylon. When the parts are assembled, the elastic comb blade *c* is inserted between the yoke members 9 of part *b* and is mounted together therewith on part *a*. In this operation, a slight pressure suffices to spring the yoke members 9 in position in which their arms engage between the curved portions 6' of the fixed combs. The distance between the yoke members 9 exceeds somewhat the length of the elastic comb *c* in order to afford the required space for the reciprocation of the latter. By springing the part *b* into position within the part *a*, the elastic cutting comb *c* therebetween is slightly flexed and biased into contact and shaving cooperation with the perforated foil 14, the teeth 16' of the comb blade at the same time engaging resiliently the teeth 6'' of the fixed combs 6.

In operation, the elastic comb blade *c* is reliably guided by engagement of the arms 21 with the inner walls of the channel portions 18 of the blade.

The novel apparatus may be used by anyone without particular skill to shave in an excellent and quick manner, as in one operation longer hairs will first be cut by the cooperation of the teeth 6'' and 16', and the stubbles left will then be shaved away by cooperation of the central curved blade portion 17 with the perforated metal foil 14. Moreover, the apparatus may be readily used for a haircut.

While the invention has been described in connection with a preferred embodiment thereof, it will be understood that it is capable of further modification, and this application is intended to cover any variations, uses, or

adaptations of the invention following, in general, the principles of the invention and including such departures from the present disclosure as come within known or customary practice in the art to which the invention pertains, and as fall within the scope of the invention or the limits of the appended claims.

What we claim is:

1. Hair cutting and shaving apparatus comprising a holder, a pair of parallel combs fixed to said holder and having curved cross-sectional profiles with opposite concave faces, each of said combs having outwardly extending teeth, the teeth of such combs pointing in opposite directions, an elastic reciprocatory cutting comb extending between and guided lengthwise of and contacting said combs and having opposite toothed longitudinal marginal portions overlying said teeth for hair cutting action and having a central curved portion provided with cutting slots, a perforated skin guard metal foil overlying said central portion, means for holding said foil in stationary relationship to said combs in contact with and biased against said central curved portion of said cutting comb for shaving action, and actuating means mounted in said holder and engaging said cutting comb to reciprocate the latter relative to said combs and to said metal foil lengthwise thereof, whereby both of said combs in operation touch the skin and perform a hair cutting operation while said skin guard prevents said central portion from touching the skin and both cooperate to perform a shaving function.

2. Apparatus as claimed in claim 1 in which said means for holding said foil comprises a pair of parallel yoke members each shaped for resilient engagement between said parallel combs extending transversely thereto, a pair of pins connected with and extending between said yokes keeping same in spaced relationship each pin being provided with a longitudinal groove, and keys inserted in said groove and engaging said foil.

3. Apparatus as claimed in claim 2 further comprising arms mounted on the ends of said pins and secured against relative rotation thereon by engagement with said keys, said arms slidably engaging the outside of said cutting comb on both sides of said central curved portion thereof.

4. Apparatus as claimed in claim 1 comprising means for holding said foil including two lateral yoke members of the cutting head, said yoke members having horseshoe shaped ends between the curved portions of said fixed combs, a pair of pins connecting fixedly said yoke members, a longitudinal groove in each said pin, a key formed of a strip of metal inserted in each said longitudinal groove, each said key having inwardly and downwardly extending teeth engaging corresponding perforations in said foil; arms mounted on said pins slidably engaging said cutting comb on both sides, the ends of said keys securing said arms against relative rotation.

References Cited in the file of this patent

UNITED STATES PATENTS

2,190,481	Nyhagen	Feb. 13, 1940
2,326,192	Andis et al.	Aug. 10, 1943
2,370,542	Jepson	Feb. 27, 1945
2,539,011	Denocenzo	Jan. 23, 1951
2,696,665	Angst et al.	Dec. 14, 1954