

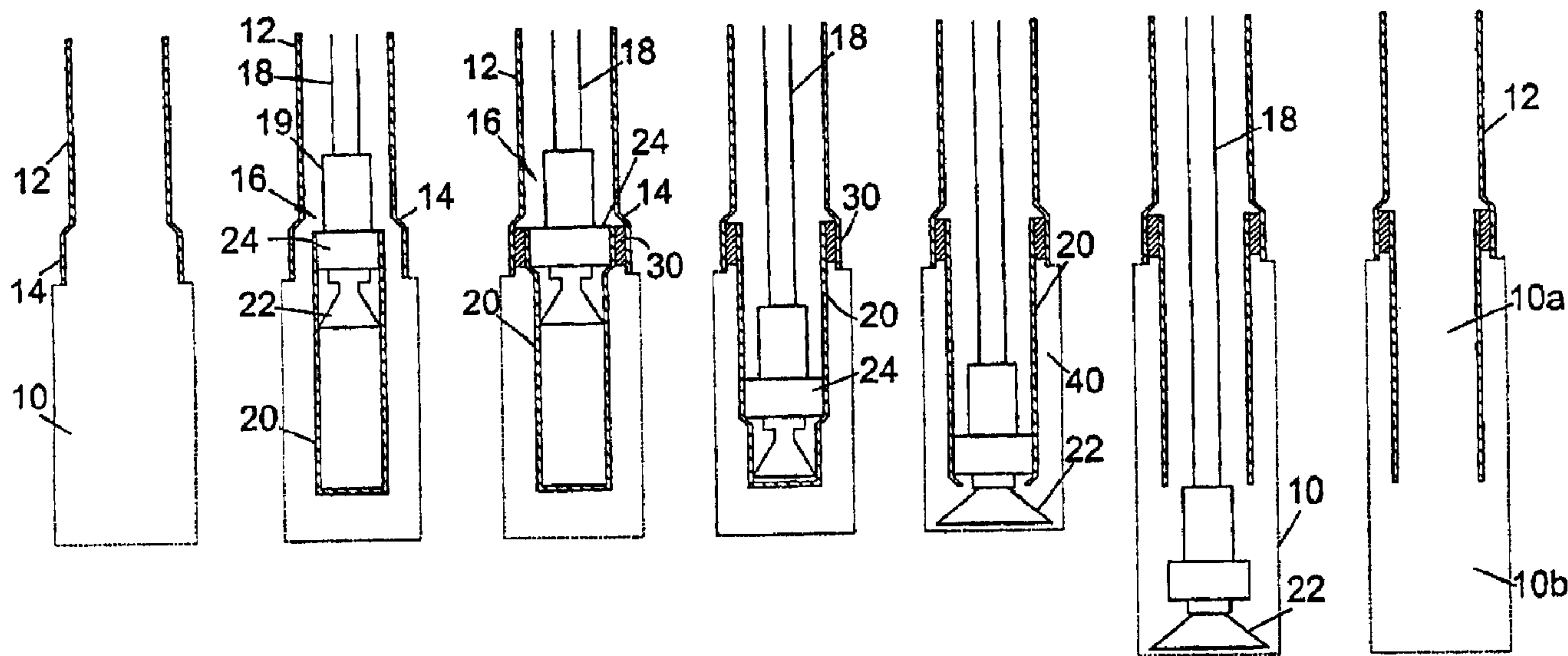

(86) Date de dépôt PCT/PCT Filing Date: 2003/03/17  
 (87) Date publication PCT/PCT Publication Date: 2003/09/25  
 (45) Date de délivrance/Issue Date: 2007/11/27  
 (85) Entrée phase nationale/National Entry: 2003/11/14  
 (86) N° demande PCT/PCT Application No.: GB 2003/001103  
 (87) N° publication PCT/PCT Publication No.: 2003/078790  
 (30) Priorité/Priority: 2002/03/16 (GB0206227.1)

(51) Cl.Int./Int.Cl. *E21B 7/20* (2006.01),  
*E21B 10/32* (2006.01), *E21B 43/10* (2006.01)  
 (72) Inventeurs/Inventors:  
SIMPSON, NEIL ANDREW ABERCROMBIE, GB;  
HARRALL, SIMON JOHN, GB  
 (73) Propriétaire/Owner:  
WEATHERFORD/LAMB, INC., US  
 (74) Agent: MARKS & CLERK

(54) Titre : GAINAGE ET FORAGE D'UN Puits AVEC UN TREPAN EXTENSIBLE  
 (54) Title: LINING AND DRILLING A WELLBORE WITH AN EXPANDABLE BIT



(57) Abrégé/Abstract:

A method of lining and drilling a bore (10) comprising mounting a first section of bore-lining tubing (20) on the lower end portion of a drill string (18); running the drill string and tubing into a bore having an unlined section and an existing tubing lined section; locating the first tubing section (20) in the unlined section; uncoupling the first tubing section (20) from the drill string (18); and drilling the bore beyond the first tubing section. The bore-lining tubing (20) may include an hanger section overlapping the existing tubing and may be expanded.

## (12) INTERNATIONAL APPLICATION PUBLISHED UNDER THE PATENT COOPERATION TREATY (PCT)

(19) World Intellectual Property Organization  
International Bureau(43) International Publication Date  
25 September 2003 (25.09.2003)

PCT

(10) International Publication Number  
WO 03/078790 A1

- (51) International Patent Classification<sup>7</sup>: E21B 43/10, 10/32, 7/20
- (74) Agents: MACDOUGALL, Donald, Carmichael et al.; Cruikshank & Fairweather, 19 Royal Exchange Square, Glasgow G1 3AE (GB).
- (21) International Application Number: PCT/GB03/01103
- (22) International Filing Date: 17 March 2003 (17.03.2003)
- (25) Filing Language: English
- (26) Publication Language: English
- (30) Priority Data:  
0206227.1 16 March 2002 (16.03.2002) GB
- (71) Applicant (for all designated States except US): WEATHERFORD/LAMB, INC. [US/US]; 515 Post Oak Boulevard, Suite 600, Houston, TX 77027 (US).
- (72) Inventors; and
- (75) Inventors/Applicants (for US only): SIMPSON, Neil, Andrew, Abercrombie [GB/GB]; Burn of Daff Farm, Downies, Portlethen, Aberdeen AB12 4QX (GB). HARRALL, Simon, John [GB/GB]; 11 Henderson Crescent, Kintore, Inverurie, Aberdeenshire AB51 0FD (GB).
- (81) Designated States (national): AE, AG, AL, AM, AT, AU, AZ, BA, BB, BG, BR, BY, BZ, CA, CH, CN, CO, CR, CU, CZ, DE, DK, DM, DZ, EC, EE, ES, FI, GB, GD, GE, GH, GM, HR, HU, ID, IL, IN, IS, JP, KE, KG, KP, KR, KZ, LC, LK, LR, LS, LT, LU, LV, MA, MD, MG, MK, MN, MW, MX, MZ, NO, NZ, OM, PH, PL, PT, RO, RU, SC, SD, SE, SG, SK, SL, TJ, TM, TN, TR, TT, TZ, UA, UG, US, UZ, VC, VN, YU, ZA, ZM, ZW.
- (84) Designated States (regional): ARIPO patent (GH, GM, KE, LS, MW, MZ, SD, SL, SZ, TZ, UG, ZM, ZW), Eurasian patent (AM, AZ, BY, KG, KZ, MD, RU, TJ, TM), European patent (AT, BE, BG, CH, CY, CZ, DE, DK, EE, ES, FI, FR, GB, GR, HU, IE, IT, LU, MC, NL, PT, RO, SE, SI, SK, TR), OAPI patent (BF, BJ, CF, CG, CI, CM, GA, GN, GQ, GW, ML, MR, NE, SN, TD, TG).
- Published:  
— with international search report  
— before the expiration of the time limit for amending the claims and to be republished in the event of receipt of amendments

[Continued on next page]

(54) Title: LINING AND DRILLING A WELLBORE WITH AN EXPANDABLE BIT

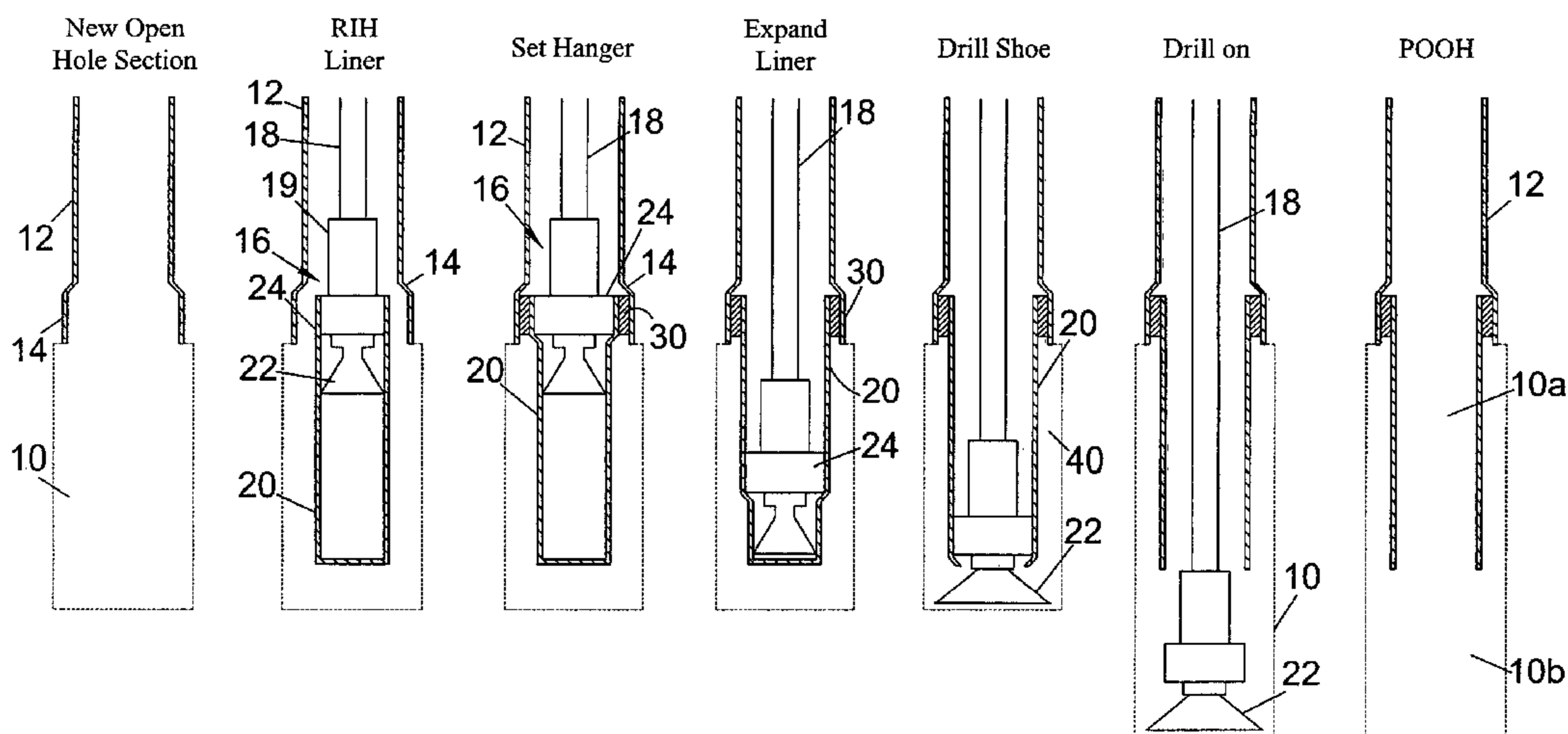

(57) Abstract: A method of lining and drilling a bore (10) comprising mounting a first section of bore-lining tubing (20) on the lower end portion of a drill string (18); running the drill string and tubing into a bore having an unlined section and an existing tubing lined section; locating the first tubing section (20) in the unlined section; uncoupling the first tubing section (20) from the drill string (18); and drilling the bore beyond the first tubing section. The bore-lining tubing (20) may include an hanger section overlapping the existing tubing and may be expanded.

WO 03/078790 A1

**WO 03/078790 A1**



---

*For two-letter codes and other abbreviations, refer to the "Guidance Notes on Codes and Abbreviations" appearing at the beginning of each regular issue of the PCT Gazette.*

**LINING AND DRILLING A WELLBORE WITH AN EXPANDABLE BIT****FIELD OF THE INVENTION**

This invention relates to an apparatus and method for use in lining and drilling a bore.

**BACKGROUND OF THE INVENTION**

In the oil and gas exploration and production industry  
5 bores are drilled from surface to access subsurface  
hydrocarbon reservoirs. The bores are typically drilled in  
sections: a section of bore is drilled using drilling  
apparatus including a bit mounted on the end of a string;  
the drilling apparatus is pulled out of the bore; a  
10 section of bore-lining tubing is run into the "open" bore;  
and the tubing is then cemented or otherwise sealed in the  
bore by filling the annulus between the tubing and the bore  
wall with cement slurry. These drilling and lining steps  
are repeated until the bore is of the required length or  
15 depth. Clearly, this can be a time-consuming operation as  
to drill and line each bore section it is necessary to make  
up and then dismantle first a drill string and then a  
running string, both of which may be several thousand  
metres long.

20 Furthermore, with conventional bore-lining techniques,  
the outer diameter of each section of bore-lining tubing

must be smaller than the inner diameter of the preceding tubing to enable the tubing to be run into the bore. Thus, a step-wise reduction in bore diameter occurs at the transition between each bore section. The reduction in available bore diameter limits the production capabilities of the well, restricts access to the well, and also requires the use of smaller diameter and thus generally less robust drilling apparatus in the lower portions of the well. A further disadvantage also arises in that the upper portions of the bore may have to be drilled to a relatively large diameter, in light of the numerous subsequent diameter reductions that must be accommodated, which increases drilling time and expense.

Some of these disadvantages may be overcome by the use of expandable bore lining tubing, which may be run in through a section of existing tubing and then expanded to a larger diameter. However, to preserve bore diameter it is important that the desired degree of overlap between adjacent sections is maintained. This may be problematic when, for example, it is not possible to run the tubing to the bottom of the bore. This may occur due to material gathering in the lower end of the bore, or the tubing encountering an unexpected bore diameter restriction.

Another proposal, as described in published PCT Patent Application WO 2000/037771 and in United States Patent 6,543,552, issued April 8, 2003, is to form the lower end of the drill

string of expandable tubing. Thus, if a problem formation is encountered in the course of a drilling operation, the tubing may be expanded without the delay that would be involved in pulling out the drilling apparatus and then running in and expanding a section of bore-lining tubing.

However, with this method, if a problem formation is encountered early in the drilling operation, only a short section of the expandable tubing is utilised to line open bore, and a significant portion of the tubing is located within the existing casing or liner and thus serves no useful purpose, and further restricts the available bore diameter. Alternatively, if no problems are encountered, the length of bore which can be lined is restricted by the length of the expandable tubing previously incorporated in the string.

Furthermore, the expandable tubing which forms the lower end of the drill string as proposed in WO 2000/037771 is likely to represent a compromise between the qualities and properties required to withstand the weight and torque which must be transmitted from surface via the tubing to the drill bit, to allow drilling fluid to be carried to the bit, to have sufficient abrasion resistance to avoid damage from contact with surrounding casing or bore wall, and to allow installation and expansion to create a safe and secure bore lining.

## SUMMARY OF THE INVENTION

5           According to one aspect of the present invention there  
is provided a method of lining and drilling a bore, the  
method including steps of: mounting a first section of  
bore-lining tubing on a drill string; running the drill  
string and tubing section into a bore having an unlined  
10 section and an existing tubing-lined section; locating at  
least a part of the first tubing section in the unlined  
section; and drilling the bore beyond the first tubing  
section.

          The invention also relates to an apparatus for  
15 implementing the method, comprising bore-lining tubing for  
mounting on a drill string, and a drill bit for mounting on  
the drill string; the bit being initially located within or  
above the bore-lining tubing and being adapted to pass  
through the tubing and then to be utilised to drill a bore.

20           Preferably, the first section of bore-lining tubing is  
expandable, but may alternatively be non-expandable.

          The upper end of the first tubing section may overlap  
the lower end of the existing tubing, or may be spaced  
therefrom.

25           Preferably, a tubing expander is mounted on the  
string, and is operated to expand the first tubing  
section. Preferably, the tubing expander is a rotary  
expander, such as described in applicant's published  
PCT Patent Application WO 2000/037766. Such an expander  
30 may operate to produce compressive yield in the

tubing wall, the resulting thinning of the wall resulting in a corresponding increase in tubing.

Alternatively, or in addition, a different expansion mechanism may be utilised, such as an axially movable cone or swage, by means of applied internal pressure, or by a combination of two or more different expansion mechanisms, such as described in applicant's published PCT Patent Application WO 2002/081863.

Preferably, a drill bit is mounted to the drill string. Most preferably, the bit is initially located within or above the bore-lining tubing. Preferably, the bit is configured to drill a larger diameter bore than the initial bit diameter, for example, the bit may be a bi-centre bit or an expandable bit, such that the bit may pass through the first tubing section and then be utilised to drill a bore of larger diameter than the internal diameter of the tubing section.

Preferably, the method includes providing a coupling, typically setting a hanger, to couple the upper end of the first tubing section to the lower end of the existing tubing. Preferably, the coupling is achieved by expanding the upper end of the first tubing into contact with the lower section of the existing tubing, which may also be subject to expansion. Alternatively, or in addition, the lower end of the existing tubing may be adapted to accommodate the expanded upper end of the first tubing by,

for example, provision of a larger diameter bell-end or the like.

The first tubing section may be cemented or otherwise sealed in the bore, typically by injecting a slurry or other fluid form of settable material into the annulus between the tubing and the bore wall. If the tubing section is expanded, the expansion may be carried out before or after cementing.

The tubing section may be expanded before, during or after drilling the next bore section.

Following drilling of the next section, the drill string and drill bit may be pulled out of hole and the method repeated using a further tubing section of length corresponding to the unlined drilled bore section.

#### 15 BRIEF DESCRIPTION OF THE DRAWINGS

These and other aspects of the present invention will now be described, by way of example, with reference to the accompanying drawings, in which:

20 Figures 1 to 7 are schematic illustrations of steps in accordance with a preferred embodiment of the present invention.

#### DETAILED DESCRIPTION OF THE DRAWINGS

The drawings illustrate stages in the lining and drilling of a bore 10, as may be used to access a

subsurface hydrocarbon-bearing formation. Figure 1 illustrates an existing bore 10 which is partially lined with casing 12, and the bore having been extended beyond the casing 12; as illustrated in Figure 1, the lower section of the bore 10 is open, or unlined. It will be noted that the lower end of the casing 12 defines a bell-end 14 of larger diameter than the upper portion of the casing, the purpose of which will become apparent in due course.

Figure 2 illustrates lining and drilling apparatus 16 in accordance with an embodiment of an aspect of the invention which has been run into the lower section of the bore 10 on the end of a drill string 18. The apparatus 16 comprises a body 19 which is coupled to the lower end of the drill string 18, a section of expandable tubing 20, an expandable drill bit 22 located within the upper end of the tubing 20, and shown in Figures 2 to 4 in unexpanded configuration, and a tubing expander 24 mounted on the body 19, the expander being initially dormant and providing support for the tubing 20.

The apparatus 16 is located in the bore 10 such that the upper end of the tubing 20 overlaps the lower end of the casing 12, and in particular is located within the casing bell-end 14. As illustrated in Figure 3, the tubing expander 24 is then activated to expand the upper end of the tubing 20 into contact with the casing 12, to create a

tubing hanger 30. The preferred expander 24 is a hydraulic fluid-activated rotary expander. Thus, supplying pressurised fluid to the expander 24, via the string 18, urges a set of expansion members radially outwards to deform the upper end of the tubing 20 and form the hanger 30. The string 18 is then rotated from surface, to rotate the apparatus 16, apart from the tubing 20 which is now coupled to the casing 12. The apparatus 16 is then also advanced axially through the tubing 20, enlarging the tubing internal diameter such that it corresponds substantially to the casing internal diameter, as illustrated in Figure 4.

On reaching the lower end of the tubing 20, the drill bit 22 is positioned beyond the end of the tubing 20, and is then expanded to assume its larger diameter configuration, as illustrated in Figure 5.

The expander 24 is then returned to the dormant configuration; the sequential activation of the expander 24 and drill bit 22 may be achieved by any appropriate means as will be apparent to those of skill in the art, such as dropping balls or darts.

The drill string 18 is then rotated at an appropriate speed for drilling, and drilling fluid is circulated through the string 18 to the bit 22. By applying appropriate weight to the bit 22, the bore 10 is drilled beyond the end of the expanded tubing 20, as illustrated in

Figure 6. Once the bore 10 has been extended by the appropriate length, the drill bit 22 is reconfigured to its retracted form and the drilling apparatus 16 pulled out of hole, leaving a further section of cased hole 10a, and a further section of open hole 10b, ready for the lining and drilling process as described above to be repeated.

It will be apparent to those of skill in the art that the above-described method provides for the efficient lining and drilling of a bore, while avoiding the disadvantages of prior art proposals.

It will also be apparent to those of skill in the art that the above-described embodiment is merely exemplary of the present invention, and that various modifications and improvements may be made thereto without departing from the scope of the present invention. For example, in an alternative embodiment the drill bit may initially be mounted to or beyond the lower end of the tubing 20, and the lower end of the drill string adapted to latch with the bit to allow drilling to commence once the tubing 20 has been located in the bore.

In another embodiment, the tubing 20 is sealed in the bore 10 by, for example, circulating a cement slurry into the annulus 40 (Figure 5) between the tubing and the bore wall before or after expansion of the tubing.

The embodiments of the invention in which an exclusive property or privilege is claimed are defined as follows:

1. A method of lining and drilling a bore, the method comprising the steps:

mounting a first section of bore-lining tubing on a drill string;

running the drill string and tubing into a bore having an unlined section and a tubing-lined section;

locating at least part of the first tubing section in the unlined section; and

without recovering the drill string to surface, drilling the bore beyond the first tubing section.

2. A method of lining and drilling a bore, the method comprising steps of:

mounting a first tubing section on a drill string;

running the drill string and the first tubing section into a pre-existing bore having an unlined section and a lined section lined with an existing tubing;

locating at least part of the first tubing section in the unlined section;

lowering a drill bit through at least a portion of the first tubing section; and

without recovering the drill string to surface, drilling the bore beyond the first tubing section.

3. A method as defined in claim 1 or 2, further comprising locating the first tubing section relative to the existing tubing such that the first tubing section overlaps the existing tubing.

4. A method as defined in claim 3, comprising locating the first tubing section such that an upper end of the first tubing section overlaps a lower end of the existing tubing.

5. A method as defined in any one of claims 1 to 4, further comprising expanding the first section of tubing.

6. A method as defined in claim 5, comprising expanding the first section of tubing at least in part by application of a mechanical expansion force.

7. A method as defined in claim 6, further comprising mounting a tubing expander on the drill string, and operating the tubing expander to expand the first tubing section.

8. A method as defined in claim 6 or 7, comprising expanding the first tubing section by rotary expansion.

9. A method as defined in claim 6, 7 or 8, comprising expanding the first tubing section by advancing an expansion cone axially through the tubing.

10. A method as defined in any one of claims 5 to 9, comprising expanding the first tubing section at least in part by application of fluid-pressure force.

11. A method as defined in any one of claims 5 to 10, comprising expanding the first tubing section by a combination of mechanical and fluid-pressure expansion forces.

## 12

12. A method as defined in any one of claims 1 to 11, further comprising mounting a drill bit on the drill string.
13. A method as defined in claim 12, comprising initially locating the bit within the first tubing section.
14. A method as defined in claim 12, comprising initially locating the bit above the first tubing section.
15. A method as defined in claim 13 or 14, further comprising passing the bit through the first tubing section, and then reconfiguring the bit to drill a bore of larger diameter than the internal diameter of the first tubing section.
16. A method as defined in any one of claims 1 to 15, further comprising setting a hanger to couple the first tubing section to the existing tubing.
17. A method as defined in any one of claims 1 to 16, comprising expanding the first tubing section into contact with the existing tubing.
18. A method as defined in claim 17, further comprising expanding the existing tubing while expanding the first tubing section.
19. A method as defined in claim 17 or 18, further comprising providing existing tubing with a larger diameter lower end to accommodate the expanded upper end of the first tubing section.

20. A method as defined in any one of claims 1 to 19, further comprising sealing the first tubing section in the bore.

21. A method as defined in claim 20, further comprising cementing the first tubing section in the bore.

22. A method as defined in any one of claims 1 to 21, wherein, following drilling of a section of bore beyond the first tubing section, the drill string and drill bit are pulled out of the bore, and the method then is repeated using a further tubing section of length corresponding to the unlined bore section which has been drilled beyond the first tubing section.

23. A method as defined in any one of claims 1 to 22, wherein the first section of bore-lining tubing comprises an enclosed lower end.

24. A method as defined in claim 23, further comprising drilling through the enclosed lower end.

25. A method as defined in claims 1 to 24, wherein the tubing-lined section includes an increased diameter portion.

26. A method as defined in any one of claims 1 to 25, wherein the first tubing section and the tubing-lined section have a substantially equivalent inner diameter following the expanding.

27. A method of lining and drilling a bore, the method comprising the steps:

mounting bore-lining tubing on a drill string;  
running the drill string and tubing into a bore having an unlined section;  
locating at least part of the tubing in the unlined section; and  
without recovering the drill string to surface, drilling the bore beyond the first tubing section.

28. A method of lining and drilling a bore, the method comprising steps of:

mounting a bore-lining tubing on a drill string coupled to a drill bit;  
running the drill string and tubing into a pre-existing bore having an unlined section;  
locating at least part of the tubing in the unlined section;  
expanding the tubing while lowering the drill bit through the tubing; and  
without recovering the drill string to surface, drilling the bore beyond the tubing.

29. Apparatus for use in lining and drilling a bore, the apparatus comprising:

bore-lining tubing for mounting on a drill string; and  
a drill bit for mounting on the drill string, the bit being initially located within or above the bore-lining tubing and being adapted to pass through the tubing and then to be utilised to drill a bore.

30. An apparatus for use in lining and drilling a bore, the apparatus comprising:

a bore-lining tubing coupled to a drill string; and  
a drill bit coupled to the drill string, the bit being

initially located in an upper portion of the bore-lining tubing and being adapted to pass through the tubing and then to be utilised to drill a bore.

31. Apparatus as defined in claim 29 or 30, wherein the drill bit is adapted to drill a bore of larger diameter than the internal diameter of the tubing.

32. Apparatus as defined in claim 29, 30 or 31, wherein the tubing is expandable.

33. Apparatus as defined in any one of claims 29 to 32, further comprising a tubing expander for mounting on the string, the expander being operable to expand the tubing.

34. Apparatus as defined in claim 33, wherein the tubing expander is a rotary expander.

35. Apparatus as defined in claim 33, wherein the tubing expander is a cone.

36. Apparatus as defined in any one of claims 29 to 35, further comprising a coupling adapted for coupling the tubing to tubing previously located in the bore.

37. Apparatus as defined in claim 36, wherein the coupling is activated by expanding the tubing into contact with the tubing previously located in the bore.

38. Apparatus as defined in claim 36 or 37, wherein the coupling is adapted for coupling an upper end of the tubing to a lower end of the tubing located in the bore.

39. A method of lining and drilling a bore, the method comprising steps of:

mounting a first tubing section on a drill string;

mounting a drill bit on the drill string;

initially locating the bit above the first tubing section;

running the drill string and the first tubing section into a pre-existing bore having an unlined section and a lined section lined with an existing tubing;

locating at least part of the first tubing section in the unlined section; and

without recovering the drill string to the surface, drilling the bore beyond the first tubing section.

40. A method of lining and drilling a bore, the method comprising the steps of:

mounting a tubing on a drill string coupled to a drill bit;

initially locating the drill bit in an upper portion of the tubing;

running the drill string and the tubing into a bore having an unlined section and a lined section; and

without recovering the drill string to the surface, drilling the bore beyond the tubing.

41. A method as defined in claim 40, further comprising coupling an expander to the drill bit.

42. A method as defined in claim 40 or 41, further comprising expanding the tubing while lowering the drill bit along the tubing.

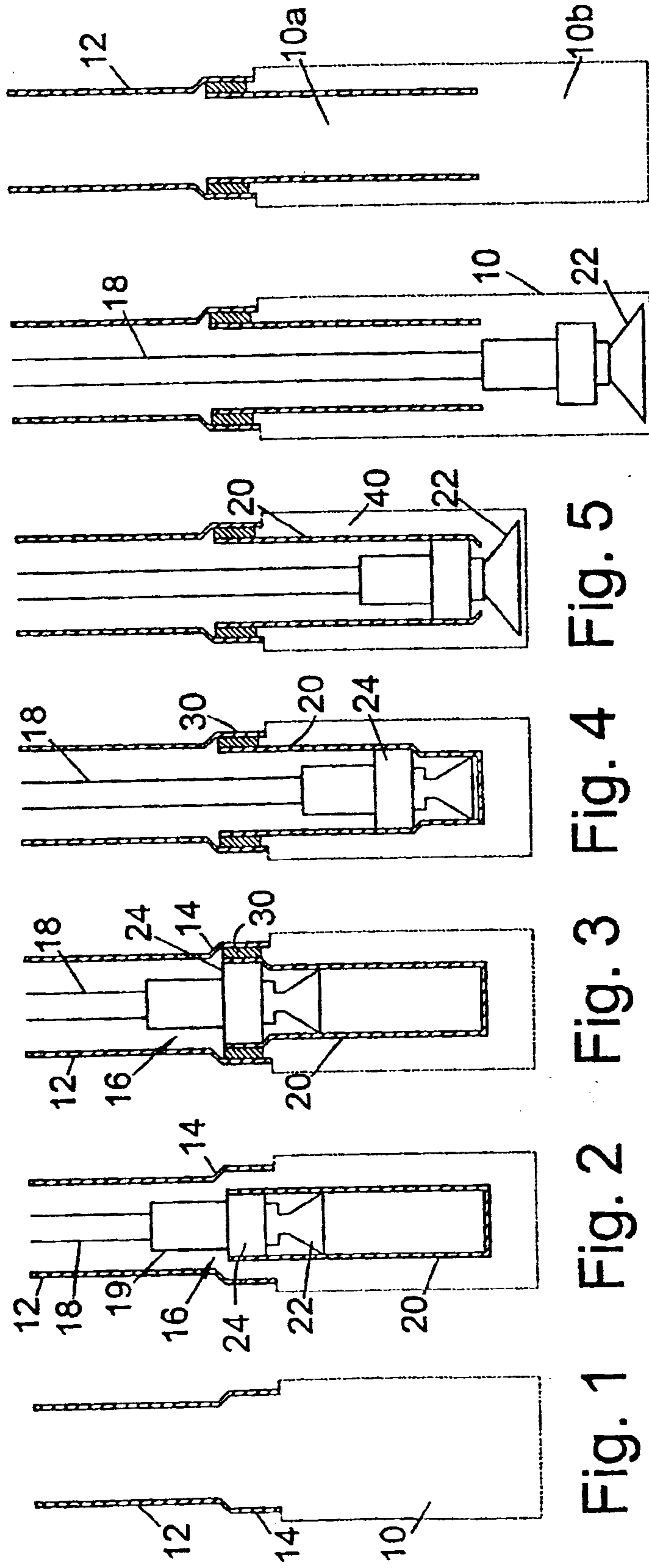

Fig. 1 Fig. 2 Fig. 3 Fig. 4 Fig. 5

Fig. 6 Fig. 7

