

(19) World Intellectual Property Organization  
International Bureau



(43) International Publication Date  
1 February 2001 (01.02.2001)

PCT

(10) International Publication Number  
**WO 01/06905 A1**

(51) International Patent Classification<sup>7</sup>: A47L 11/40,  
G05D 1/02, B25J 9/00

Building, Wills Oval, Newcastle Upon Tyne NE7 7RW (GB). STODDART, Barry [GB/GB]; 364 Durham Road, Low Fell, Gateshead NE9 5AP (GB).

(21) International Application Number: PCT/US00/20109

(74) Agents: REED, T., David et al.; The Procter & Gamble Company, 5299 Spring Grove Avenue, Cincinnati, OH 45217-1087 (US).

(22) International Filing Date: 24 July 2000 (24.07.2000)

(25) Filing Language: English

(81) Designated States (*national*): AE, AG, AL, AM, AT, AT (utility model), AU, AZ, BA, BB, BG, BR, BY, BZ, CA, CH, CN, CR, CU, CZ, CZ (utility model), DE, DE (utility model), DK, DK (utility model), DM, DZ, EE, EE (utility model), ES, FI, FI (utility model), GB, GD, GE, GH, GM, HR, HU, ID, IL, IN, IS, JP, KE, KG, KP, KR, KR (utility model), KZ, LC, LK, LR, LS, LT, LU, LV, MA, MD, MG, MK, MN, MW, MX, MZ, NO, NZ, PL, PT, RO, RU, SD, SE, SG, SI, SK, SK (utility model), SL, TJ, TM, TR, TT, TZ, UA, UG, US, UZ, VN, YU, ZA, ZW.

(26) Publication Language: English

(30) Priority Data:  
9917348.6 24 July 1999 (24.07.1999) GB

(71) Applicant (*for all designated States except US*): THE PROCTER & GAMBLE COMPANY [US/US]; One Procter & Gamble Plaza, Cincinnati, OH 45202 (US).

(72) Inventors; and

(84) Designated States (*regional*): ARIPO patent (GH, GM, KE, LS, MW, MZ, SD, SL, SZ, TZ, UG, ZW), Eurasian patent (AM, AZ, BY, KG, KZ, MD, RU, TJ, TM), European patent (AT, BE, CH, CY, DE, DK, ES, FI, FR, GB, GR, IE, IT, LU, MC, NL, PT, SE), OAPI patent (BF, BJ, CF, CG, CI, CM, GA, GN, GW, ML, MR, NE, SN, TD, TG).

(75) Inventors/Applicants (*for US only*): BOTTOMLEY, Ian [GB/GB]; 17 Howick Street, Alnwick, Northumberland NE66 1UZ (GB). COATES, David [GB/GB]; 14 Percy Road, Shilbottle, Northumberland NE66 2HF (GB). GRAYDON, Andrew, Russell [GB/GB]; 42 The Wills

[Continued on next page]

(54) Title: ROBOTIC SYSTEM

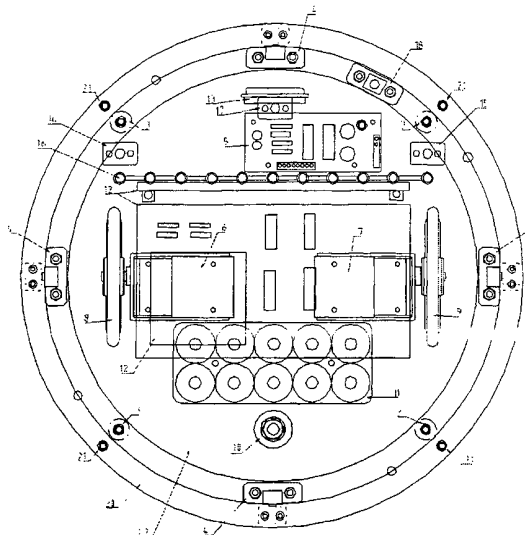

(57) Abstract: A self-propelled robot is disclosed for movement over a surface to be treated. The robot has a power supply (11) and a pair of wheels (8, 9) driven by motors (6, 7) for moving the robot over the surface. The robot is provided with means (120, 121) for providing sonic or ultrasonic energy to the surface. A mechanism (113, 115, 16) is also provided for controllably depositing a fluent material on to the surface. Navigation sensors (4, 13, 18, 21) provide signals for enabling the robot to navigate over the surface and one or more detectors (14, 15, 17) detect the presence of the material on the surface and provide signals indicative of its presence. A control system (100) receives the signals from the sensors and detectors and controls the motors and the depositing mechanism in dependence upon the signals received from the sensors and detectors.

WO 01/06905 A1



**Published:**

- *With international search report.*
- *Before the expiration of the time limit for amending the claims and to be republished in the event of receipt of amendments.*

*For two-letter codes and other abbreviations, refer to the "Guidance Notes on Codes and Abbreviations" appearing at the beginning of each regular issue of the PCT Gazette.*

**ROBOTIC SYSTEM**

The present invention relates to robotic systems and, more particularly to a mobile robotic system capable of movement over a surface and capable of treating the surface. In particular, the invention relates to robotic systems suitable for use in cleaning of floors, carpets and other floor coverings.

The care of carpets and other floor coverings presents a considerable challenge to the consumer. By virtue of their fibrous construction, carpets are able to absorb liquid spills and to pick up particulate soil which then becomes entrained within the carpet fibres. Such soiling is unsightly and can also lead to abrasion and shortening of the lifetime of the carpet.

There are relatively few methods of cleaning carpets available to the consumer, the most common by far being the vacuum cleaner. This relies on vigorous beating of the carpet fibres and/or strong suction. Other known methods also rely on strong suction to remove dirt from the carpet. To provide these powerful suction forces, an equally powerful motor is necessary and as a result, vacuum cleaning devices tend often to be very heavy and noisy.

For the developers of self-propelled autonomous or semi-autonomous robots for floor care, there is a further significant disadvantage. Robots are typically powered by rechargeable batteries which can deliver only a limited supply of current before recharging becomes necessary. The demands of powerful and heavy motors are such that the batteries can only provide the necessary power over a short time period which is not compatible with the time required to clean the floor. This means that by reason of power-consumption, self-propelled floor-cleaning robots can only supply a superficial level of cleaning, and need to be used in a regime that also includes use with a conventional, mains-powered device.

The present invention is aimed at providing a self-propelled robot which can overcome such problems, in particular, which does not require a powerful motor, and yet which still delivers a high level of cleaning and of soil and stain removal from carpets and other floor coverings.

According to a first aspect of the present invention, there is provided a self-propelled robot for movement over a surface to be treated, the robot comprising

- a power supply;
- 10 a traction mechanism receiving power from the power supply, for moving the robot over the surface;
- a means for applying sonic or ultrasonic energy to the surface;
- a plurality of navigation sensors providing signals for enabling the robot to navigate over the surface;
- 15 and a control system for controlling the traction mechanism in dependence upon the signals received from the navigation sensors.

The invention is applicable to both semi-autonomous and autonomous robotic systems. Semi-autonomous robots are robots which are self-propelling but which rely for navigational guidance on transmitters, receivers and sensors to establish a coordinate system by which the robot navigates, in effect learning the location of obstacles within its field of movement. More recently it has been proposed to allow a robot to move without establishing a coordinate system, instead relying on the sensing of *ad hoc* stimuli to enable the robot to navigate around obstacles. For example, it has been proposed to provide a robotic vacuum cleaner operating along these lines. Self-navigational, self-propelling robotic systems of this type are referred to as autonomous robots.

The robots of the invention also incorporate a means for applying sonic or ultrasonic energy to a surface. As used herein, sonic or ultrasonic energy refers to energy provided in the form of mechanical pressure or stress waves

and which have a frequency spectrum typically spanning the range from a few cycles/second (Hz) to a few billion cycles/second. The term 'sonic' refers generally to the frequency range for sound waves which, for human hearing, is approximately from about 20Hz to about 20,000Hz. Pressure waves of frequency above human hearing are referred to as 'ultrasonic'. The term 'means for applying sonic or ultrasonic energy to a surface' is sometimes referred to herein as 'the sonic device'. Preferred herein are sonic devices which deliver energy in the range from about 1 to about 100,000 Hz. In especially preferred embodiments, energy is applied to the surface in the form of sonic energy having a frequency in the range from about 1 to about 20,000 Hz, preferably from about 2 to about 2000 Hz, more preferably from about 10 to about 1000 Hz.

The power output of the sonic device can vary across a broad range, but in preferred robotic devices, the power output falls generally in the range from about 0.1 to about 10, preferably from about 0.5 to about 5 watts. The rate at which energy is applied to the surface also depends upon the speed of the robot relative to the surface and in preferred devices, the robot has a maximum speed relative to the surface in the range from about 1 to about 100, preferably from about 5 to about 50 cm/sec.

In general terms, the sonic device for use herein comprises a frequency generator mechanically coupled to a vibrating cleaning transducer which is adapted to physically contact the surface to be treated. The cleaning transducer can take the form of a vibrating, smooth sonic horn or tip but in preferred embodiments, the cleaning transducer is a vibrator formed of flexible bristles. The vibrating cleaning transducer can be adapted for vibration either longitudinal or transverse to the surface to be treated, but a transverse arrangement is preferred herein.

To help mediate the transfer of energy to the surface to be treated, the self-propelled robots of the invention

preferably further comprise a mechanism for controllably depositing a fluent material (for example, a cleaning composition) on to the surface, such that the sonic or ultrasonic energy is applied both to the deposited fluent material and to the underlying surface. The fluent material is preferably deposited in an amount at least sufficient to moisten the surface and to facilitate the sonic or ultrasonic cleaning process but without causing difficult removal problems, for example, an amount in the range from about 1 to about 150, preferably from about 5 to about 50 ml/m<sup>2</sup>.

Thus, in a further aspect of the invention, there is provided a self-propelled robot for movement over a surface to be treated, the robot comprising

- 15 a power supply;
- a traction mechanism receiving power from the power supply, for moving the robot over the surface;
- a mechanism for controllably depositing a fluent material on to the surface;
- 20 a means for applying sonic or ultrasonic energy to the deposited fluent material and underlying surface;
- a plurality of navigation sensors providing signals for enabling the robot to navigate over the surface;
- and a control system for controlling the traction mechanism in dependence upon the signals received from the navigation sensors.

In the case of robots designed for autonomous operation in a typically cluttered, unstructured domestic or institutional environment, the need to avoid obstacles can lead to the robot tracing a path which involves repeated passing over the same areas of the surface. Excessive navigational movement of this kind can result in over-treatment of the surface which is not only wasteful of the product used for the treatment (a serious problem where the payload is restricted), but may also damage the surface or

otherwise actually be harmful. In the case of sonic or ultrasonic cleaning processes as disclosed herein, moreover, over-treatment of the surface is not only unnecessary but it can also lead to a difficult removal challenge.

5 Thus, in preferred embodiments, the robots of the invention additionally comprise one or more detectors adapted to detect the presence of the material on the surface and to provide signals indicative thereof. At the same time, the robot's control system is adapted to control  
10 the traction mechanism and the depositing mechanism in dependence upon the signals received from the navigation sensors and detectors.

The detectors may comprise one or more sensors arranged to detect the edge of a section of previously deposited  
15 product. Suitable deposition detectors include one or more radiation sources and/or detectors, moisture detectors, reflectivity meters, conductivity meters etc. Detectors may be disposed laterally of the robot's drive wheels, preferably forward thereof.

20 By detecting the application of the fluent material, which may be a liquid or gaseous fluid or else a flowable powder, the over-application of material can be avoided or minimised by either navigating the robot around areas already treated and/or by controlling the depositing  
25 mechanism to reduce or stop the deposit of material over such previously treated areas.

The material deposited may, for example, be a carpet cleaning composition, a hard surface cleaning composition, or one of a number of compositions applied simultaneously,  
30 or successively, and may include a marker, the presence of which can be detected to provide detection of the extent of treatment material deposition. Such a marker may have a limited detection life, for example, 12, 24 or 48 hours.

35 Material for treatment is preferably contained within a reservoir on the robot and may comprise suitable

compositions for treatment of floors, carpets and other floor coverings.

The robots of the invention can, if desired, additionally comprise means for removing contaminant material from the surface after the application of sonic or ultrasonic energy thereto. Suitable means for removing contaminant include low-powered suction devices and absorbent materials that are capable of removing contaminant by a 'wicking' mechanism, for example, comminuted wood pulp, creped cellulose wadding, hydrogel-forming polymer gelling agents, creped tissues, creped nonwovens containing fibers comprised of absorbent polymers, modified cross-linked cellulose fibers, capillary channel fibers, absorbent foams, thermally bonded airlaid materials, absorbent sponges, synthetic staple fibers, polymeric fibers, peat moss, and combinations thereof.

Thus, according to another aspect of the invention, there is provided a self-propelled robot for movement over a surface to be treated, the robot comprising

- a power supply;
- a traction mechanism receiving power from the power supply, for moving the robot over the surface;
- a means for applying sonic or ultrasonic energy to the surface;
- a means for removing contaminant material from the surface after the application of sonic or ultrasonic energy thereto.

- a plurality of navigation sensors providing signals for enabling the robot to navigate over the surface;
- and a control system for controlling the traction mechanism in dependence upon the signals received from the navigation sensors.

The invention also includes a method of treating a surface, especially floors, carpets and other floor



coverings, using an autonomous, self-propelled sonic or ultrasonic robot as defined above. The treatment method is particularly aimed at cleaning the surface, but may also be used for other purposes, for example, to provide protective treatment, for example for stain and soil protection, fire protection, UV protection, wear resistance, dust mite control, anti microbial treatment and the like, as well as treatment to provide an aesthetic benefit such as odorization/deodorization. The treatment method may also find application on other surfaces such as synthetic floor coverings, ceramics or wood. The robot may also be used to apply coatings to either enhance aesthetics or to act as a protective layer.

The robot preferably comprises a plurality of navigation sensors providing signals for enabling the robot to navigate over the surface, and one or more detectors adapted to detect the presence of deposited material on the surface and provide signals indicative thereof. The navigation sensors may include one or more collision sensors and/or proximity sensors. The collision sensors may include one or more lateral displacement sensors arranged on a peripheral sensor ring to provide 360° collision detection, and/or one or more vertical displacement sensors.

Utilising a generally circular shape together with a control regime which scans for the best direction of escape after the robot has become stuck (say in a corner) is especially advantageous. Furthermore, it may be additionally advantageous to detect the angle of any collision, in order to optimise the robots subsequent angle of movement away from the obstacle.

The traction mechanism preferably includes left and right, coaxially disposed drive wheels with corresponding drive motors which are preferably provided with pulse-width modulated drive signals.

For depositing material on the surface, an array of delivery ports, e.g. spray nozzles, may extend generally

parallel with the drive wheel axis, preferably extending to the same lateral extent as the deposition detectors.

The robot further preferably comprises a control system for controlling deposition of the material dependent on the signals received from the one or more detectors and sensors. In preferred embodiments, the control system functions to control deposition of the material (e.g. to avoid or minimise over-application) by a combination of strategies comprising a) navigating the robot around previously-treated areas of the surface (referred to herein as the 'navigation strategy'; and b) controlling the depositing mechanism to stop or reduce the deposit of fluent material on to the surface as the robot passes over such previously-treated areas (referred to herein as the 'deposition rate control strategy'). In practice, the control system arbitrates between the two strategies depending on the signals received from the navigation sensors and deposition detectors. The ability of the control system to arbitrate between the two strategies, for example to make a rapid judgment on whether to cross or navigate around previously-treated areas and whether to maintain, reduce or stop deposition accordingly, is an important feature for ensuring controlled deposition in the context of a fully autonomous robot designed to operate in the cluttered, unstructured and track-free environment typically found in domestic and institutional situations.

Alternatively, the control system can be designed to control deposition purely following a deposition rate control strategy, in other words, by controlling the depositing mechanism to stop or reduce the deposit of fluent material on to the surface as the robot passes over previously-treated areas. Of course, systems depending purely on deposition rate control require less complicated electronics than the preferred combined-strategy systems described above. On the other hand, single strategy systems

can be less efficient in terms of the time required to complete the task in hand.

Preferably, the control system has a hierarchical architecture and includes one or more microprocessor  
5 controllers or microcontrollers for controlling higher-level functions, and providing higher-level instructions and a plurality of lower-level function modules adapted to receive signals from the sensors and detectors and to provide control signals in response thereto. The traction mechanism  
10 control and product dispensing signals are preferably issued to a traction mechanism controller and to a product dispensing controller via a manifold or bus arranged to receive signal inputs from the microprocessor and a plurality of sub-processors each corresponding to a  
15 respective navigation sensor or the like. By this means, a distributed processing system can be employed to provide a high level of flexibility in control strategy, whilst allowing simple connection of the sub-processors, thus to reduce the complexity and expense of the control system.  
20 The various processors preferably include neural network functionality to provide behavioural characteristics appropriate to the chosen task of the robot, the behavioural characteristics of the processors preferably being moderated by a group of generic moderators providing necessary  
25 arbitration between the control instructions from the various processors. The higher-level functions preferably include one or more functions selected from determination of the robot being stuck, room size estimation, clutter level determination, and battery monitoring. The lower-level  
30 modules are preferably analog neural networks which provide, for example, edge follow and dispense control functions, together, preferably, with cliff sensing, collision detection, speed reduction and random movement functions.

One example of a self-propelled robot constructed in  
35 accordance with the present invention, and its method of

operation, will now be described with reference to the accompanying drawings in which:-

Figure 1 is an underneath plan view of the robot;

Figure 2 is a functional diagram of the robot; and

5 Figures 3A-C illustrate neural net aspects of part of the robot's control system.

As can be seen from Figure 1, the robot of the present example is substantially circular in overall plan view. A simple plate-like chassis 1 supports both the mechanical and electrical components of the robot. The plate-like chassis 10 1 supports the body 2 of the robot on resilient rubber mountings 3 which allow the body to move relative to the chassis when a force is applied, eg by collision with an object, to a sensor ring 20 which is disposed around the periphery of the body. Four displacement sensors 4 placed 15 at 90E intervals around the robot measure lateral displacement of the body 2 relative to the chassis 1 and inform the control system of contact with an external object. The displacement sensors 4 are based on linear Hall Effect devices which produce a voltage which is proportional 20 to the strength of the magnetic field in which they immersed. Each sensor consists of a small permanent magnet mounted on the body shell support ring 20 and a Hall Effect device mounted on the main chassis 1. When the body moves 25 with respect to the chassis (as happens during a collision) the voltage produced by the Hall Effect device varies and can be used to signal the control system that an object has been encountered. By examining the signals from all four sensors the angle and magnitude of the collision can be 30 deduced. These sensors allow displacements in the order of 0.1 mm to be reliably detected. A fifth sensor 18, of the same type as the displacement sensors 4, measures vertical displacement of the body shell to accommodate forces produced by objects which are of insufficient height to 35 cause lateral body movement. In an alternative construction, these sensors may be superseded by a single

custom-built sensor which can measure lateral and vertical displacement simultaneously. Such an integrated sensor may be optical in nature utilising an array of photo detectors mounted on the chassis and a light source which is mounted  
5 on the body support ring.

A single forward facing time-of-flight ultrasound sensor 13 is mounted at the front of the robot and is used to allow the robot to gather more information regarding its surroundings than can be achieved by the displacement  
10 sensors 4 alone. This ultrasound sensor 13 is based on a Polaroid® ranging module Polaroid 6500 series sonar ranging device, Polaroid reference 615077, the data from which is pre-processed by a dedicated unit 5 on which the sensor 13 is located. An ultrasonic sensor unit 5, containing the  
15 ultrasonic sensor 13 itself and a suitable electronic interface, are mounted on the body to provide proximity information to the robot's control system.

Left and right motors 6, 7 are provided to drive corresponding left and right wheels 8, 9 each with a soft rubber tyre, via an integral reduction gearbox, to provide  
20 motive power to the robot. A single castor 10 mounted at the rear of the robot completes the drive/movement system and allows the chassis to move forwards or backwards and rotate on the spot. Varying the rotational speed of the  
25 left and right motors 6, 7 allows the robot to be steered in any direction. The speed of the motors is controlled by pulse width modulating the voltages applied to the motors. This involves switching the motor current on and off very rapidly (100,000 times a second) and varying the ratio of  
30 'on' time to 'off' time. This is a very efficient way to control the power to the motors and hence their speed.

Power for the robot, including the motors 6, 7 and the control system is provided by means of a battery pack 11 mounted on the chassis 1. To protect the components of the  
35 robot from tampering and from damage a cover or housing (not shown) is attached to the body 2 to house the robot

components. In the preferred embodiment, this is part-spherical or dome-like in shape.

A row of spray nozzles 16 and a pump 115 (not shown in Figure 1) provide a means of dispensing treating fluid on to the surface to be treated and detectors 14,15,17 are provided to detect the presence of the treating fluid (or a suitable additional marker fluid). The three sensor units 14, 15, 17, one placed in front of each of the drive wheels and the third 17 placed centrally, emit light at a wavelength which excites a fluorescent dye in the product being detected. These sensor units incorporate a pair of light sensitive devices positioned at 90E to the robot's direction of travel and spaced 20mm apart, which can detect light produced by the fluorescent dye. By examining the intensity of the light detected by these devices the edge of a section of previously deposited product can be detected and hence followed. In an alternative construction, the three sensor units 14, 15, 17 pass a small electrical current through the floor covering by virtue of an array of stainless steel contacts which are designed to glide over the floor covering surface. The conductivity of the floor covering will vary depending upon whether or not it has recently been sprayed with product. By examining the conductivity of the floor covering, the edge of previously deposited product can be detected and hence followed.

In an alternative construction, in which fluid is to be dispensed to an edge or corner, the positioning of the sprays is modified. The modification is such that the spray is able to dispense to the edge of the robot or beyond, for example, either by positioning nozzles at the very periphery of the underside or by additional nozzles which protrude from the casing and are directed such that they spray beyond the perimeter of the robot.

A cleaning transducer 121 is situate immediately adjacent the row of spray nozzles 16. The cleaning transducer is mechanically coupled to a frequency generator

120 capable of providing sonic energy in the frequency range from about 10 to about 1000Hz with a power output of from about 0.5 to about 5 watts. The cleaning transducer takes the form of a vibrator bar 123 having a head 124 composed of flexible bristles 125 adapted for linear or rotational vibration in a direction generally transverse to the surface to be treated. In an alternative embodiment, the fluent material is dispensed through a row of dispensing nozzles set within the vibrator bar itself. In another embodiment (not shown), means 126 is also provided for removing contaminant material from the surface after the application of sonic or ultrasonic energy thereto.

The robot's control system comprises various circuit boards and components which are not shown in Figure 1 in detail, but which are broadly indicated by reference numerals 12 in Figure 1.

The control system will now be described in further detail.

Two purposes of the control system of an autonomous mobile robot such as that of the example are to allow the robot to move within a physical environment in safety and to enable it to perform useful tasks. To do this the robot must be aware of its immediate surroundings and be able to react to particular circumstances in particular ways. A robot intended for an unconstrained domestic environment needs to have certain basic skills, such as a collision detection skill, which might cause it to stop upon collision with an object and then take evasive action before resuming its previous activity.

In the case of collision detection, the sensors 4, 18, 13, which sense impacts with and proximity to objects, will inform the control system of the angle of impact and its force. The control system must react very quickly to this stimulus and prevent any further motion in this direction. A conventional approach to this problem would be to have a computer monitor the collision sensors and act upon the data

to stop the motors and then perform some form of avoidance manoeuvre. This is perfectly feasible, but if the same computer is required simultaneously to perform other tasks, for example, such as in the present case, monitoring other  
5 sensors and performing navigational mathematics, it soon reaches a point where the speed and power of the on-board computer required becomes prohibitively expensive if reaction times are to be acceptable.

The alternative, adopted in the present invention, is  
10 to use discrete modules that perform functions in a way analogous to the reflexes of a biological organism. The advantage of this system are obvious: the main processor can merely issue high level commands such as move or turn and is left free to perform other abstract tasks.

This alternative is a form of hierarchical distributed  
15 processing and allows the control system to be composed of simple modules that together yield faster response times than a non-distributed system of the same cost. Another significant advantage of distributed processing is its  
20 inherent robustness. If a system employing a conventional single processor approach suffers a failure, it can leave the system in an unsafe state, which in the case of a robot might allow it to crash into objects or people. The distributed approach can be designed so as to have a much  
25 greater degree of fault tolerance, rendering the occurrence of complete system failures much less likely.

Distributed processing can be implemented using  
conventional computers connected together by some form of  
network, but these tend to be expensive to design and  
30 implement. The approach adopted in the present invention is to simulate biological neural networks in real analogue hardware to provide a system that consists of behavioural  
modules, which are designed to perform individual tasks. These behaviours are managed by a simple micro controller,  
35 which performs higher level tasks such as mathematical



functions to estimate room size or a strategy for escaping from under a table.

The control system 100 will now be described with reference to Figures 2 and 3. Figure 2 illustrates the functional relationship of the control system components.

The control behaviours used on the robot can be divided into two basic types, Low Level and High Level. Low Level behaviours are implemented in hardware as discrete neural blocks or modules 101-105, while High Level behaviours are software algorithms running on a micro controller 106.

The functions of the Low level behaviour modules 101-105 are now described in detail:-

Cliff - To prevent the robot falling down stairs it is equipped with four cliff detectors 21 which warn of vertical hazards and provide signals to the cliff behaviour module 101. The cliff detectors 21 are active infra red proximity sensors which comprise a modulated light source which emits a beam of infra red light directed at the target (in this case the floor), and an infra red detector which monitors the intensity of the light which is reflected. When the sensor is directed over a cliff the intensity of the reflected light decreases and the sensor informs the control system of the hazard. This behavioural function has very high priority and when active operates to manoeuvre the robot away from the hazard and return it to a course which is modified to avoid cliff type drops.

Edge Follow - The Edge Follow module 104 provides a behavioural function which uses information from the sensors 14,15,17 which allow the robot to find the edge of a previously treated area (as described above) and to travel along that edge to produce a faster scan of the floor surface.

Random - In the absence of any edges the robot moves in a random direction under the action of a random

movement module 114 until an object is encountered or the edge follow behaviour is activated.

Collide - The collision detection module 102 takes input from the displacement sensors 4,18 and operates  
5 so that upon encountering an obstacle the robot stops, reverses a small distance, then turns away from the object in a direction that depends upon the angle of impact, which is determined from the signals of the displacement sensors 4,18.

10 Reduce Speed - When an object is detected by the ultrasound sensor unit 5 within a pre-set range limit, the forward speed of the robot is reduced by the Reduce Speed module 103 to minimise the impact force generated when contact with the object occurs.

15 Dispense - A dispense control module 105 has inputs from a fluid level sensor 203 and sensors 14, 15, 17 via the Edge Follow module 104. If the UV sensors 14, 15, 17 report untreated carpet in the direction of travel the treatment chemical is dispensed until  
20 treated areas are encountered or fluid level reaches a lower limit.

High level behaviours are determined within the microcontroller 106 and comprise the following functional modules:-

25 Stuck - A routine 107 determines if there have been more than a chosen number of collisions in a select period and causes the robot to stop and use the ultrasound range finder 5, 13 to find the longest clear path and move in that direction. The robot will rotate  
30 on the spot, by operating the wheels 8, 9 in opposite directions, looking for the longest clear path. When the best direction is discovered the robot will move off in that direction.

35 Estimate Room size - By using statistics gathered from the ultrasound sensor 13 and measuring the time between collisions the routine 108 is able to estimate the area

of the room. This is used to determine how long the robot should take to treat a particular room.

Estimate clutter level - By comparing estimates of room size against collisions per minute a routine 109 is able to deduce a factor describing the complexity of the room. This can then be used to modify the run time to allow for the level of clutter.

Battery Monitor - A battery monitor routine 110 checks the state of the battery by monitoring the output voltage and current. It uses this information to estimate how long the battery will be able to support the robot's systems before a re-charge is needed. When the monitor routine decides that the battery state is approaching the point where reliable operation is no longer possible, the user is warned by illumination of a battery low indicator. If the robot is allowed to continue to operate without being re-charged the monitor routine will shut the robot down in a safe and controlled fashion when power levels reach a predetermined point. Nickel Cadmium or Nickel Metal Hydride batteries require careful charging to ensure maximum capacity and life span and the monitor routine also controls the charging cycle of the battery to ensure that these needs are met.

Traditionally neural network designers have insisted that every neuron in a network is connected to every other neuron in that network. Whilst this allows the network the greatest level of flexibility, very many (even as high as 90%) of these connections will never be used. The present system allows pre-configured neural networks to be connected together in a much less complex way allowing the behaviour of the robot to dynamically adjust to the immediate environment in a continuous fashion.

This so-called "Manifold Architecture" comprises an analogue bus or manifold 111, connecting all the behaviour modules 101-105 and their associated actuators to each

other. Four generic moderators arbitrate between the behaviours, and give rise to a prototype behaviour of their own which regulates the overall activity of the robot via a motor controller 112 and dispensing fluid pump controller 113 driving the pump 115. These generic moderators sum all the excitatory and inhibitory inputs and apply a non-linear transfer function to the results. The outputs from these moderators form the inputs to the motor controllers.

In order to explain the function of the manifold architecture, it is necessary to describe the basic neural aspects of the control system. Figures 3A-C will be referenced for this purpose.

A single neuron (see Fig. 3A) has three basic types of connections, excitatory inputs which cause the neuron to 'fire', inhibitory inputs which suppress activity and the output which represents the state of the neuron. Additionally neurons may have other properties such as Decay which causes the output to fall slowly over time, and Threshold which suppresses all output until the sum of all the input exceeds a certain level.

Figure 3B shows (by way of example) a simplified representation of the collide behaviour and the manifold system in neural notation.

The collision sensors 4 are represented in Fig. 3B as 1, 2, 3 and 4 and are buffered and normalised by sensor pre-processors 5, 6, 7 and 8. The outputs of the sensor pre-processors are each fed into a single neuron 9, 10, 11 and 12 configured as a pulse stretcher with a time constant of approximately 5 seconds. The outputs of these neurons are connected to the rest of the network formed by neurons 13 to 28 where the pattern of connections, and transfer characteristics of the neurons give rise to the behaviour itself. The outputs of this network are connected via the connections 41 to 48 to the manifold summators (generic moderators) 29 to 32 where the signals are summed and the outputs 37 to 40 form the inputs to the left and right motor

controllers (not shown in this figure). Connections from another unspecified behaviour (of which there may be many) are shown as 50 to 57. Connection 49 is a subsumption input, which is used to disable the entire behaviour under control  
5 of the scheduler software running on a microcontroller or another higher priority neural behaviour. The sensor outputs are also made available to the microcontroller so that high level behaviours such as clutter level estimation may have access to any data produced.

10 In the event of a direct collision whilst travelling straight ahead the following is true:

The front collision sensor 1 produces a pulse as contact with an obstacle occurs. This pulse is amplified by the sensor pre-processing element 5 and  
15 passed to the input neuron 9. This neuron is configured to stretch the width of an input pulse (when that pulse exceeds a predetermined input threshold) to approximately 5 seconds. The output from the input neuron 9 is simultaneously fed to four other neurons  
20 13, 14, 15 and 16. These 'hidden layer' neurons are configured to act as attenuators or in neural terms 'weights', and therefore change the amplitude of the applied signals. Neurons 13 and 15 are set to produce an output level of 10 (maximum) when excited and the  
25 outputs are connected to the output neurons 22 and 26 which when excited apply signals to the manifold instructing the motors to stop moving forward. Neurons 14 and 16 are set to produce an output of 5 (half) when excited and their outputs are connected to the output  
30 neurons 23 and 27 which when excited apply signals to the manifold instructing the motors to move the robot backwards. This part of the behaviour itself, would theoretically lead to a situation where the robot would repeatedly collide and retreat in a straight line  
35 from an obstacle, but inherent inaccuracies in the control system and drive mechanics coupled with the

fact that the probability of a perfect head on collision is remote, means that the other collision strategies which involve the left and right sensors, will cause the robot to turn as it reverses from an obstacle and produces a useful behaviour.

The manifold function will now be described in detail with reference to Fig. 3C. The manifold as it's name implies brings together all the output from the robots various neural behaviours, sums it together and provides the inputs to the motor controllers. Fig. 3C shows the section which controls the right hand motor controller; the left hand section is identical.

Connection 41 is effectively the 'Go forward right' input and 42 is 'Don't go forward right'. These two opposing inputs are fed into the excitatory and inhibitory inputs of neuron 29. If values of Go forward 6 and don't go forward 3 are applied simultaneously, neuron 29 outputs a value of 3, but if the values are reversed ie. Go forward 3 and don't go forward 6, neuron 29 produces 0. This is most important as it allows a behaviour to inhibit motion in a particular direction without causing motion in the opposite direction.

Neuron 30 performs the same task as 29 except it's inputs are 'Go backwards' 43 and 'Don't go backwards' 44.

Neuron 29 is connected to the excitatory input of 33 which in turn drives the 'Go forward' input of the right hand motor controller via connection 37. Neurons 30 and 34 are connected to the 'Go backward' input of the right hand motor controller via connection 38. The motor controller sums these inputs so that Go forward 8 and Go Backward 4 simultaneously applied on connections 37 and 38 respectively will result in the right wheel rotating forward at a speed of 4.

Neurons 33 and 34 also have inhibitory connections where the forward signal path is connected to the reverse path and vice versa. This allows non-linear behaviour of

the manifold and as the strength of these connections is increased, the robot becomes less likely to enter a stable state, where no motion occurs due to behaviours with conflicting interests asserting themselves simultaneously.

5 Further details of some of the various sensors and their operation will now be given:-

The ultrasound sensor unit 5 has a pre-processor which manages the sensor 13, providing timing pulses etc., and provides the high level behaviour with continuous 'range to  
10 target' data and a simple range warning to the reduce speed behaviour module 103. The continuous output is used by the stuck behaviour module 107 which rotates the robot through 360E whilst looking for a clear path down which the robot can escape and is also used by the room size and clutter  
15 estimation behaviour modules 109, 108.

To perform the task of dispensing the treatment compositions on to a surface, it is desirable to know which areas of the surface have already been treated.

A marker agent, added to the formulation in question,  
20 has characteristic properties such as absorption or emission of light at a known frequency, or fluorescent behaviour which can be detected by the robot. Examples of such markers are luminol, which can be made to react with hydrogen peroxide to emit light, and substituted coumarins  
25 such as 7-hydroxy or 4-methyl-7-hydroxy variants which are highly fluorescent but undergo ring opening reactions to form a non-fluorescent derivative.

For detection purposes, a light source and corresponding photodiode detectors 14, 15, 17 are placed  
30 left and right in front of the drive wheels 6,7 of the robot in order to detect said marker chemical and enable the control system to follow the edge of a previous pass. In this manner, a structured dispensing pattern can be established. Moreover, the detector can be linked, via a  
35 negative feedback system, to the dispensing array, thereby to avoid the deposition of formulation on to an area of

surface that has already been treated. When no area of the floor can be found that has not been treated, the actual time taken is compared with data provided by the estimated room size behaviour module 108, and if the two are within acceptable limits, the treatment of the floor is deemed complete. The characteristic properties by which the marker is detected either decay within 24-48 hours of application (by aerial oxidation or photolytic decomposition) or, in the case of a two stage treatment method, a second chemical may be applied over the first, neutralising the characteristic properties of the marker chemical.

An alternative means of achieving this desired behaviour is to use moisture detection to identify areas of the surface which have already been treated. In this case, the inherent moisture of a liquid formulation is used to detect treated surfaces via moisture sensing arrays which are positioned left and right in front of the drive wheels 6,7 of the robot. Again, this system can be used to enable the robot to follow the edge of a previous pass.

In cases where a hard floor surface is being treated, the reflective properties of the floor may be used to detect which areas of floor have been treated. A high intensity light source directs light on to the floor where, following reflection, it is subsequently detected by a photodiode detector. These are positioned left and right in front of the drive wheels 6,7 of the robot. Again, this system can be used to enable the robot to follow the edge of a previous pass. In this case, the ability of a formulation to reduce the reflectivity of the floor is harnessed to enable its detection.

Fluent materials preferred for use herein are liquid cleaning compositions, especially cleaning compositions known or suitable for use in carpet cleaning. Preferably the cleaning compositions are formulated so as to leave substantially no visible residue on carpet surfaces and to contain a high level of volatile materials. In preferred



embodiments, the liquid cleaning compositions include water (typically from about 85% to about 99%, preferably from about 85% to about 98%)), an organic solvent (typically from about 0.1% to about 10%, preferably from about 0.5% to about 4%) and a surfactant (typically from about 0.05% to about 2%, preferably from about 0.1 to about 1%). The preferred solvent is butoxy propoxy propanol ("BPP"), and the preferred surfactant is selected from anionic surfactants, nonionic surfactants, cationic surfactants and mixtures thereof.

In an especially preferred embodiment of the invention, the liquid cleaning composition includes: from about 0.1% to about 10% by weight of an organic solvent; from about 0% to about 7% by weight of hydrogen peroxide; from about 0% to about 3% by weight of a peroxide-stabilizing amount of a chelating agent; from about 0.05% to about 2% by weight of a deterative surfactant; and the balance water and other optional ingredients.

What is Claimed is:

1. A self-propelled robot for movement over a surface to be treated, the robot comprising  
5 a power supply (11);  
a traction mechanism (6-9) receiving power from the power supply, for moving the robot over the surface;  
a means (120,121) for applying sonic or ultrasonic energy to the surface;  
10 a plurality of navigation sensors (4,13,18,21) providing signals for enabling the robot to navigate over the surface;  
and a control system (12,100) for controlling the traction mechanism in dependence upon the signals received  
15 from the navigation sensors.
2. A self-propelled robot according to claim 1 wherein the means for applying sonic or ultrasonic energy has an energy output in the range from about 0.1 to about 10, preferably  
20 from about 0.5 to about 5 watts and the robot has a maximum speed relative to the surface in the range from about 1 to about 100, preferably from about 5 to about 50 cm/sec.
3. A self-propelled robot according to claim 1 or 2  
25 wherein the energy applied to the surface is sonic energy having a frequency in the range from about 1 to about 20,000 Hz, preferably from about 2 to about 2000 Hz, more preferably from about 10 to about 1000 Hz, and wherein the means for applying sonic energy comprises a frequency  
30 generator (120) and a vibrating cleaning transducer (121) adapted to physically contact the surface to be treated.
4. A self-propelled robot according to claim 3 wherein the cleaning transducer is adapted for vibration transverse to  
35 the surface to be treated.

- 5 5. A self-propelled robot according to any of claims 1 to 3 additionally comprising a mechanism (16) for controllably depositing a fluent material on to the surface and wherein the sonic or ultrasonic energy is applied both to the deposited fluent material and underlying surface.
- 10 6. A robot according to claim 5 additionally comprising one or more detectors adapted (14,15,17) to detect the presence of the material on the surface and provide signals indicative thereof, and wherein the control system (12,100) is adapted to control the traction mechanism and the depositing mechanism in dependence upon the signals received from the navigation sensors and detectors.
- 15 7. A robot according to claim 6, wherein the detectors comprise one or more sensors (14,15) arranged to detect the edge of a section of previously deposited product.
- 20 8. A robot according to claim 6 or 7, wherein the detectors include one or more radiation sources and/or detectors, moisture detectors, reflectivity meters, conductivity meters.
- 25 9. A robot according to any of claims 1 to 8 additionally comprising a means (126) for removing contaminant material from the surface after the application of sonic or ultrasonic energy thereto.
- 30 10. A self-propelled robot for movement over a surface to be treated, the robot comprising  
a power supply (11);  
a traction mechanism (6-9) receiving power from the power supply, for moving the robot over the surface;  
a mechanism (16) for controllably depositing a fluent  
35 material on to the surface;

a means (120,121) for applying sonic or ultrasonic energy to the deposited fluent material and underlying surface;

5 a plurality of navigation sensors (4,13,18,21) providing signals for enabling the robot to navigate over the surface;

and a control system (12,100) for controlling the traction mechanism in dependence upon the signals received from the navigation sensors.

10

11. A self-propelled robot according to claim 10 wherein the energy applied to the surface is sonic energy having a frequency in the range from about 1 to about 20,000 Hz, preferably from about 2 to about 2000 Hz, more preferably from about 10 to about 1000 Hz, and wherein the means for applying sonic energy comprises a frequency generator and a vibrating cleaning transducer adapted to physically contact the surface to be treated.

20 12. A robot according to claim 10 or 11 additionally comprising one or more detectors adapted (14,15,17) to detect the presence of the material on the surface and provide signals indicative thereof, and wherein the control system (12,100) is adapted to control the traction mechanism and the depositing mechanism in dependence upon the signals received from the navigation sensors and detectors.

13. A self-propelled robot for movement over a surface to be treated, the robot comprising

30 a power supply (11);

a traction mechanism (6-9) receiving power from the power supply, for moving the robot over the surface;

a means (120,121) for applying sonic or ultrasonic energy to the surface;

a means (126) for removing contaminant material from the surface after the application of sonic or ultrasonic energy thereto.

5 a plurality of navigation sensors (4,13,18,21) providing signals for enabling the robot to navigate over the surface;

and a control system (12,100) for controlling the traction mechanism in dependence upon the signals received from the navigation sensors.

10

14. A self-propelled robot according to claim 13 wherein the energy applied to the surface is sonic energy having a frequency in the range from about 1 to about 20,000 Hz, preferably from about 2 to about 2000 Hz, more preferably  
15 from about 10 to about 1000 Hz, and wherein the means for applying sonic energy comprises a frequency generator and a vibrating cleaning transducer adapted to physically contact the surface to be treated.

20 15. A robot according to any of claims 1 to 14, wherein the navigation sensors include collision sensors comprising one or more lateral displacement sensors (4) arranged on a peripheral sensor ring (20) to provide 360° collision detection, and/or one or more vertical displacement sensors  
25 (18).

16. A robot according to any of claims 1 to 15, wherein the control system (100) has a hierarchical architecture and includes one or more microprocessor controllers or  
30 microcontrollers (106) for controlling higher-level functions and providing higher-level instructions; and a plurality of lower-level function modules (101-104,114) adapted to receive signals from the navigation sensors and detectors (4,13-15,17,18,21), if any, and having processors  
35 to provide control signals in response thereto.

17. A robot according to claim 16, wherein the lower level function module processors (101-104,114) include neural network functionality to provide behavioural characteristics appropriate to the chosen task of the robot, the behavioural characteristics of the processors being moderated by a group  
5 of generic moderators (111,29-32) providing arbitration between the control instructions from the various processors (101-104,114).

10 18. A robot according to claim 17, wherein the lower-level modules (101-104,114) comprise analog or digital neural networks which provide functions selected from edge follow and dispense control functions, cliff sensing, collision detection, speed reduction and random movement functions.

15

19. A method for cleaning floors, carpets and other floor coverings using an autonomous, self propelled, sonic or ultrasonic cleaning robot.

20

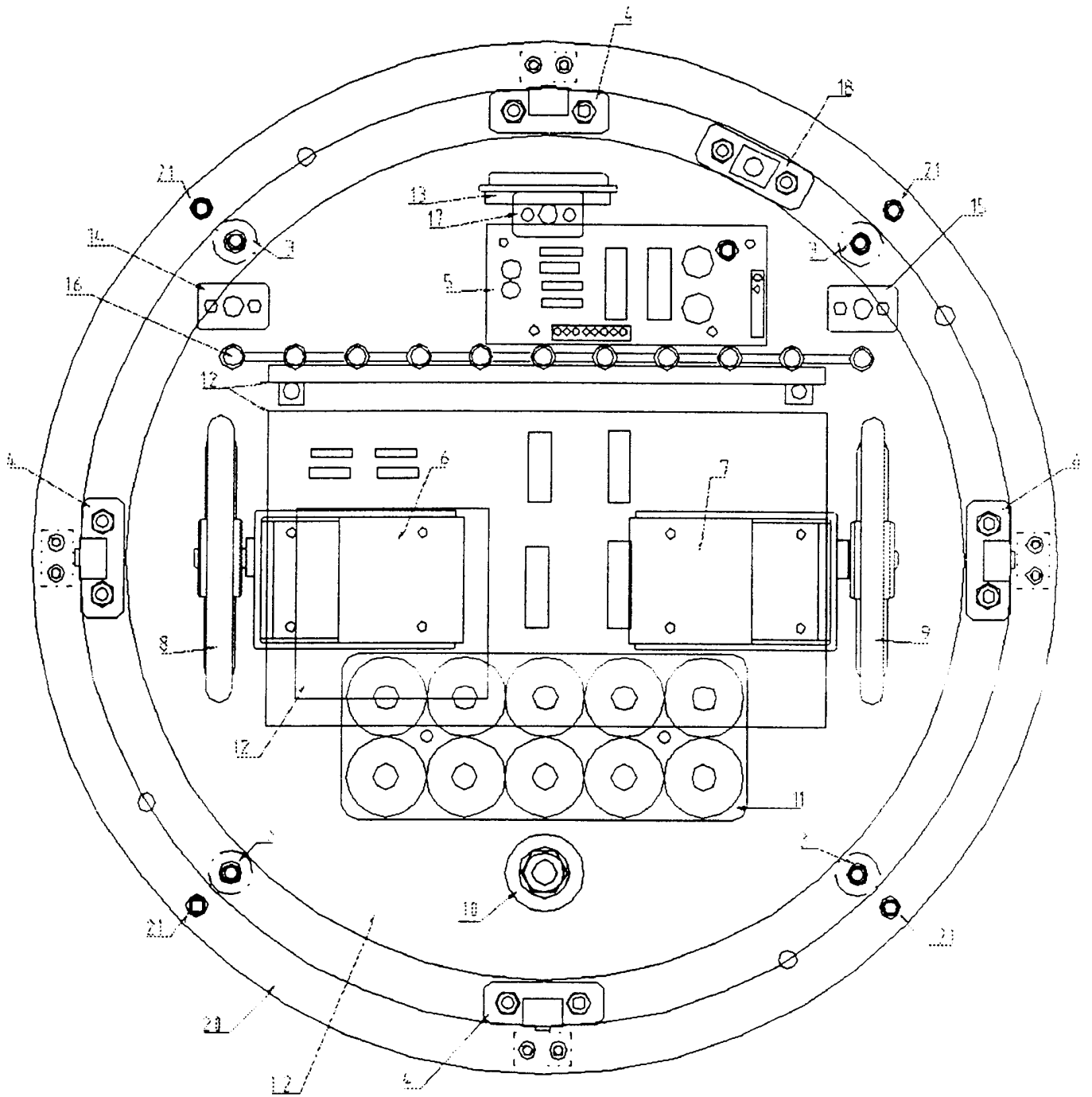

Figure 1

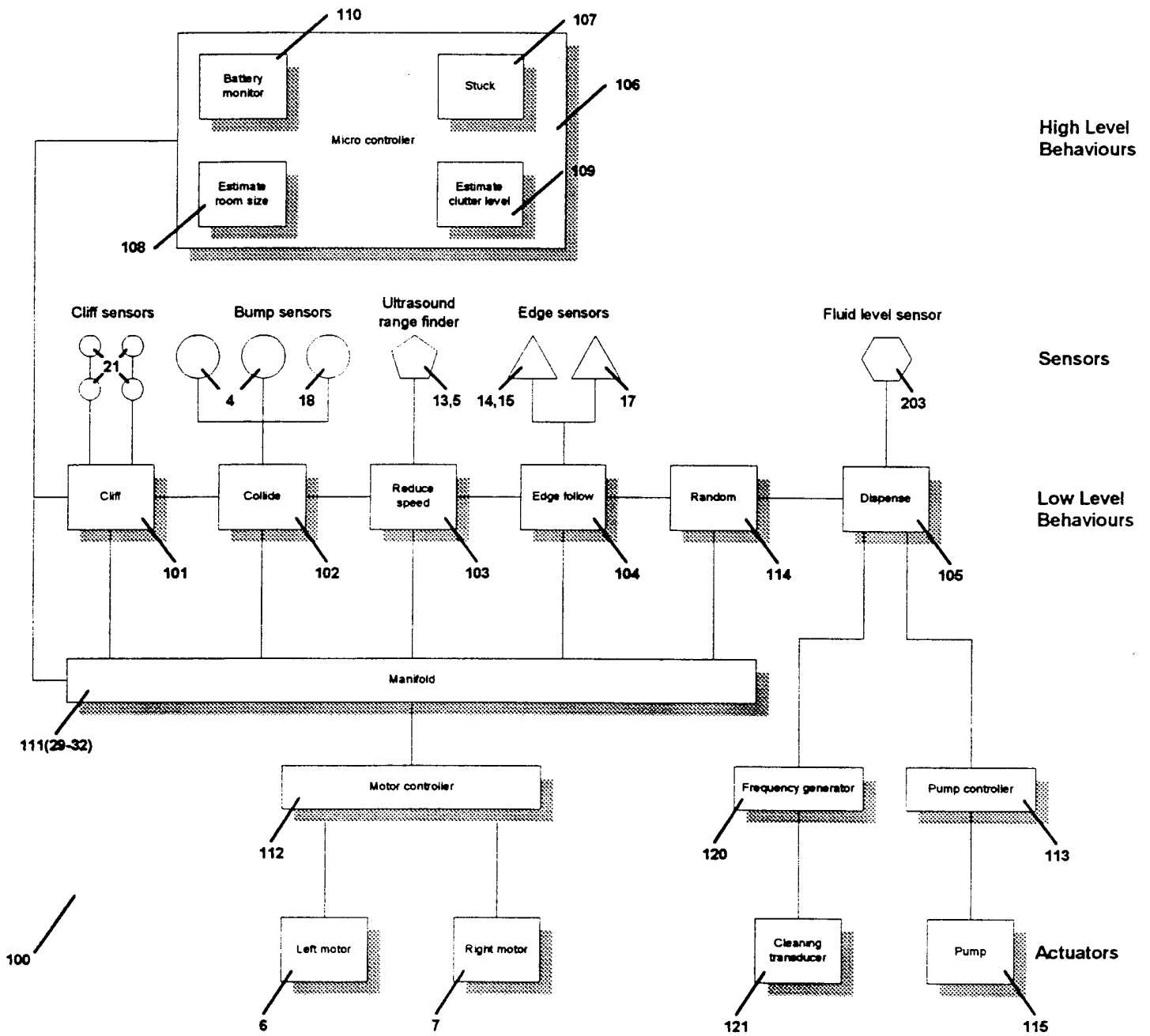

Figure 2



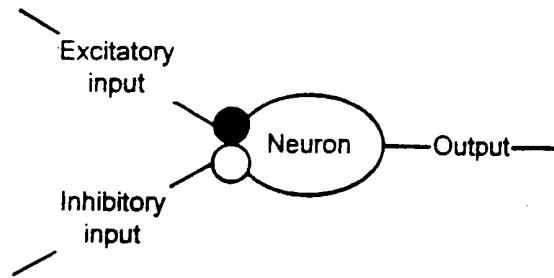

Figure 3A

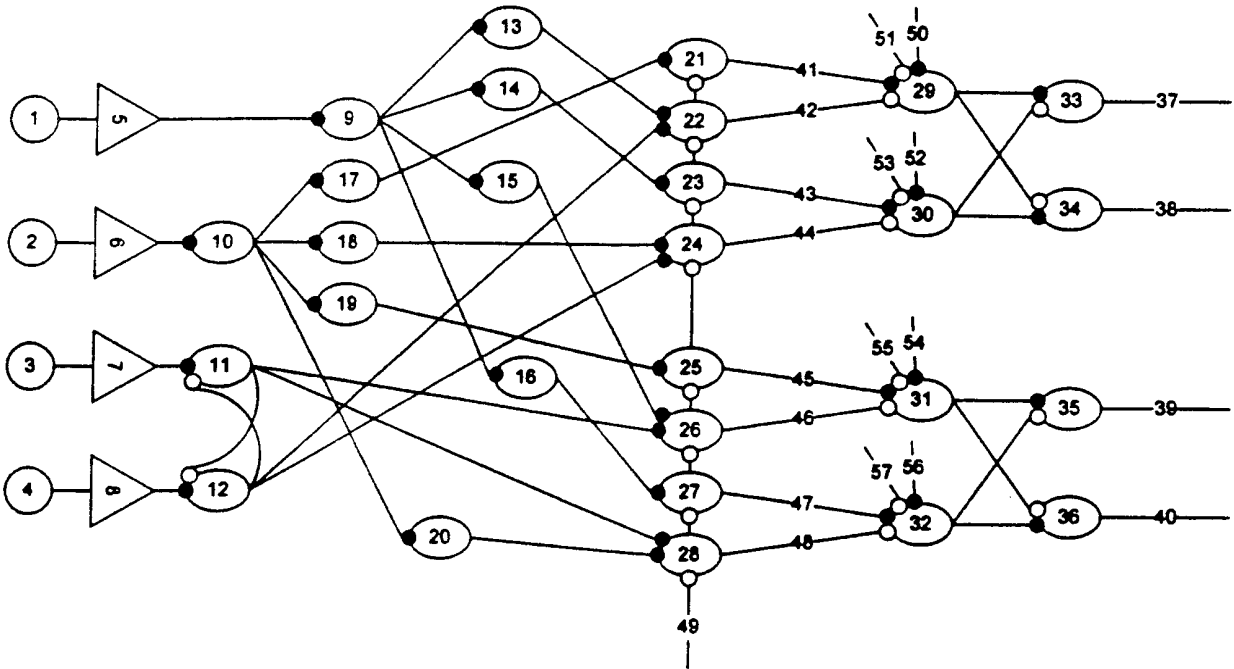

Figure 3B

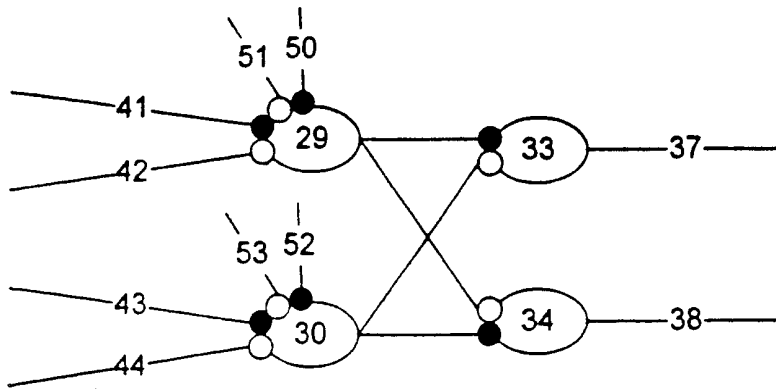

Figure 3C

# INTERNATIONAL SEARCH REPORT

International Application No PCT/US 00/20109
---

**A. CLASSIFICATION OF SUBJECT MATTER**  
 IPC 7 A47L11/40 G05D1/02 B25J9/00

According to International Patent Classification (IPC) or to both national classification and IPC

**B. FIELDS SEARCHED**  
 Minimum documentation searched (classification system followed by classification symbols)  
 IPC 7 B25J A47L G05D B08B

Documentation searched other than minimum documentation to the extent that such documents are included in the fields searched

Electronic data base consulted during the international search (name of data base and, where practical, search terms used)  
 EPO-Internal, WPI Data, PAJ

**C. DOCUMENTS CONSIDERED TO BE RELEVANT**

Category °	Citation of document, with indication, where appropriate, of the relevant passages	Relevant to claim No.
Y	DE 35 36 974 A (KNEPPER HANS REINHARD) 23 April 1987 (1987-04-23) abstract; figures 3A,3B column 7, line 51 -column 8, line 47 ---	1,5-10, 12,13,19
Y	US 4 103 519 A (DAVIDSON AMBER CHARLES) 1 August 1978 (1978-08-01) abstract; figure 5 --- -/--	1,5-10, 12,13,19

Further documents are listed in the continuation of box C.       Patent family members are listed in annex.

° Special categories of cited documents :

*A* document defining the general state of the art which is not considered to be of particular relevance *E* earlier document but published on or after the international filing date *L* document which may throw doubts on priority claim(s) or which is cited to establish the publication date of another citation or other special reason (as specified) *O* document referring to an oral disclosure, use, exhibition or other means *P* document published prior to the international filing date but later than the priority date claimed	*T* later document published after the international filing date or priority date and not in conflict with the application but cited to understand the principle or theory underlying the invention *X* document of particular relevance; the claimed invention cannot be considered novel or cannot be considered to involve an inventive step when the document is taken alone *Y* document of particular relevance; the claimed invention cannot be considered to involve an inventive step when the document is combined with one or more other such documents, such combination being obvious to a person skilled in the art. *&* document member of the same patent family
---	---

Date of the actual completion of the international search  <b>15 November 2000</b>	Date of mailing of the international search report  <b>24/11/2000</b>
--	---

Name and mailing address of the ISA European Patent Office, P.B. 5818 Patentlaan 2 NL - 2280 HV Rijswijk Tel. (+31-70) 340-2040, Tx. 31 651 epo nl, Fax: (+31-70) 340-3016	Authorized officer  <b>Lumineau, S</b>
--	--

INTERNATIONAL SEARCH REPORT

Intel onal Application No  
PCT/US 00/20109

C.(Continuation) DOCUMENTS CONSIDERED TO BE RELEVANT

Category *	Citation of document, with indication, where appropriate, of the relevant passages	Relevant to claim No.
A	<p>SEKIGUCHI M ET AL: "BEHAVIOR CONTROL FOR A MOBILE ROBOT BY MULTI-HIERARCHICAL NEURAL NETWORK" PROCEEDINGS OF THE INTERNATIONAL CONFERENCE ON ROBOTICS AND AUTOMATION,US,WASHINGTON, IEEE COMP. SOC. PRESS, vol. -, 15 May 1989 (1989-05-15), pages 1578-1583, XP000044339 ISBN: 0-8186-1938-4 the whole document</p>	15-18
A	<p>HINKEL R ET AL: "AN APPLICATION FOR A DISTRIBUTED COMPUTER ARCHITECTURE- REALTIME DATA PROCESSING IN AN AUTONOMOUS MOBILE ROBOT" PROCEEDINGS OF THE INTERNATIONAL CONFERENCE ON DISTRIBUTED COMPUTING SYSTEMS,US,WASHINGTON, IEEE COMP. SOC. PRESS, 13 June 1988 (1988-06-13), pages 410-417, XP000040240 the whole document</p>	16-18
A	<p>US 3 166 773 A (GENERAL MOTORS CORP.) 26 January 1965 (1965-01-26)  the whole document</p>	1,3-5, 10,11, 13,14,19
A	<p>US 5 341 540 A (SOUPERT JEAN-LOUIS D C ET AL) 30 August 1994 (1994-08-30) abstract; figures 1,2 column 7, line 60 -column 8, line 6 column 4, line 67 -column 5, line 68</p>	1,10,13, 15,18,19

# INTERNATIONAL SEARCH REPORT

Information on patent family members

International Application No

PCT/US 00/20109

Patent document cited in search report	A	Publication date	Patent family member(s)	Publication date
DE 3536974	A	23-04-1987	NONE	
-----				
US 4103519	A	01-08-1978	NONE	
-----				
US 3166773	A	26-01-1965	NONE	
-----				
US 5341540	A	30-08-1994	FR 2648071 A	14-12-1990
			AT 104838 T	15-05-1994
			AU 5839490 A	07-01-1991
			CA 2058929 A	08-12-1990
			DE 69008530 D	01-06-1994
			EP 0476023 A	25-03-1992
			EP 0584888 A	02-03-1994
			WO 9014788 A	13-12-1990
			FR 2695342 A	11-03-1994
			JP 5502743 T	13-05-1993
			MC 2184 A	16-09-1992
-----				