

Clute & Marshall,

Work Holder.

No. 108,569.

Patented Oct. 25, 1870.

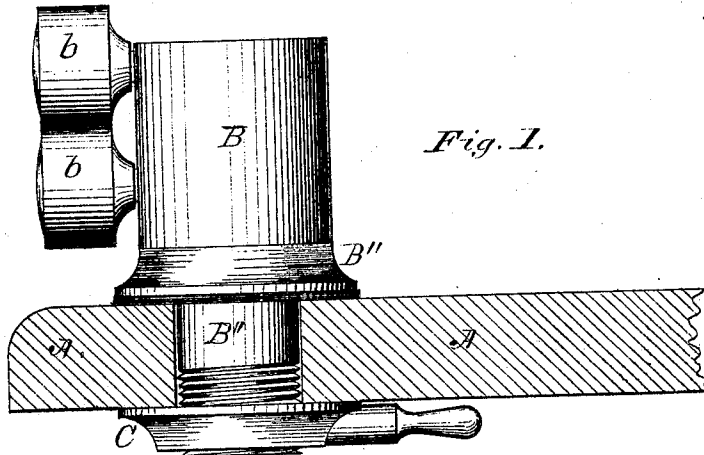

Fig. 1.

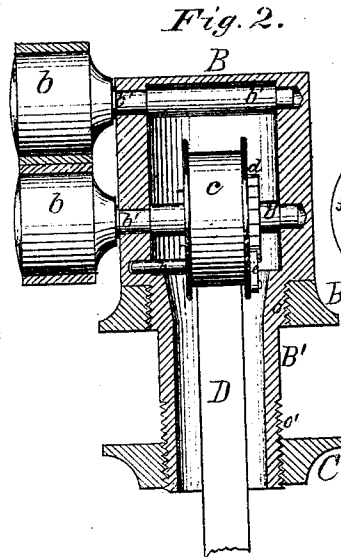

Fig. 2.

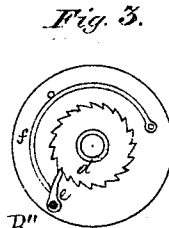

Fig. 3.

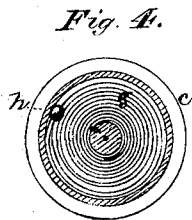

Fig. 4.

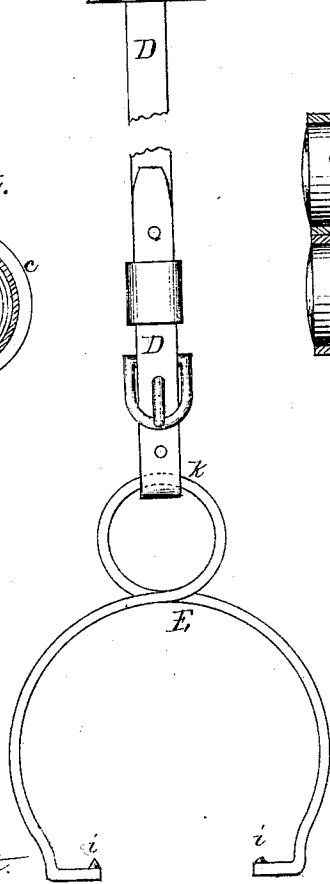

Fig. 5.

Witnesses:
John F. Fennell,
H. K. Hyatt.

Inventors
Nicholas Clute
Oliver W. Marshall
By A. Crawford
attorney

United States Patent Office.

NICHOLAS CLUTE, OF SCHENECTADY, NEW YORK, AND OLIVER W. MARSHALL OF HARTFORD, CONNECTICUT.

Letters Patent No. 108,569, dated October 25, 1870.

IMPROVEMENT IN WORK-HOLDERS.

The Schedule referred to in these Letters Patent and making part of the same.

We, NICHOLAS CLUTE, of Schenectady, in the county of Schenectady in the State of New York, and OLIVER W. MARSHALL, of Hartford, in the county of Hartford in the State of Connecticut, have invented certain Improvements in Work-Holders, of which the following is a specification.

As work-holders, for holding the work while being operated upon, such as sewing, hemming, basting, or ripping old work, have heretofore been constructed, they only take hold of the work and rigidly hold it in a single position, and the holder is incapable of feeding the work along as the operator and the condition of the work may require, without releasing the work from the holder and moving it along by hand to have it held in a different place.

The object of our invention is to not only rigidly hold the material being wrought upon in any desired position, but to feed the material along, so that the relative position of the operator to the machine and work will always be the same, whether the operation be sewing, ripping, or other work that may need holding while being wrought upon; and

It consists in the construction of the device, whereby the above result is accomplished.

Figure 1 is an upright view of the holder.

Figure 2 is an upright sectional view, showing the interior arrangement of the operating parts;

Figure 3 is an end view of the operating-cylinder;

Figure 4 is a view of the spring in the cylinder; and

Figure 5 is a top view of the case and working-cylinder.

A is a section of the top of a table or stand to which the holder is attached.

B is the case that contains and holds some of the operating-parts, and is made in two parts, as seen in fig. 5, in order to place and hold therein the cylinder *c*, which contains the coiled spring *g*, and has the journals of the shafts *b b* cut equally in each half, as seen in fig. 2.

B' is the shank part of case B, and passes through the table-top A.

B'' is a nut with an internal screw-thread, that screws onto screw-thread *o* on the case B, and serves to hold the two parts of the case together, and the shafts *b b* and cylinder *c* in their places.

C is a hand-lever nut, that screws onto the lower end of the shank of case B, and underneath the table-top, and fastens the holder securely to the table, as seen in fig. 1.

b b are two revolving feed-rollers, secured firmly to horizontal shafts *b b*, which are journaled and freely revolve in case B. These rollers *b b* are covered with

or made wholly of India-rubber, in order that their surfaces may be yielding, so that they will not slide upon each other, or the material placed between them slip; and to insure this condition the surfaces are made to press hard against each other, by having the journal-boxes in case B made a trifle nearer each other than the distance would be as simply placed against each other with their shafts *b b* parallel.

Upon the lower shaft *b* is secured a cylinder, *c*. This cylinder *c* is closed at its ends, and contains a coiled spring, *g*.

To the outer end of the spring *g* is a winch or lever, by which the spring is held in proper tension, as seen in fig. 2.

To one head of the cylinder is a ratchet, *d*, which is held by pawl *e* and spring *f*, and is similar to a watch-spring, its cylinder or barrel, and ratchet and pawl.

The inner end of the coiled spring *g* is securely attached to the hub of the cylinder in the usual way.

Upon the outer side of cylinder *c*, and securely attached thereto, is strap D, which extends downward through the shank of case B, and low enough to receive stirrup E, with its coiled spring-top *k* at its lower end, and have the stirrup the right height to place the operator's foot therein.

The stirrup E is constructed of wire, and bent in the form seen in fig. 1. The top part *k*, formed so that it acts a spring and loop or ring, to which the strap D is attached.

At each end the wire is bent in the form as seen in said fig. 1, and terminating in upwardly-projecting points *i i*.

This construction of stirrup allows of different sizes of boot or shoe, as it can be sprung open or closed as desired, and the points *i i*, together with the spring of its sides, will prevent its slipping off of the shoe or boot when in use.

The case B may be made in any convenient form other than the one adopted and herein described.

By our construction and arrangement of the parts of the device a simple, efficient, and cheap work-holder is produced having all the holding qualities that any other work-holder can have, and, at the same time, the additional function or means of automatically moving the work, being held and wrought upon along, so that the best relative position of the operator to the work can always be secured.

The device is so placed together as that the coiled spring is wound up by the hand-winch *h* to its proper tension, the cylinder turned so as to wind upon itself a portion of strap D, and having the shaft *b* with the cylinder and the winch *h* of spring *g* in the positions

as seen in fig. 2, when the two parts of case B are secured together by nut B', and the holder is ready to be put in the proper place for operation.

When the several parts are thus arranged and placed together and secured to a table or stand, the work is introduced between the rollers *b b*, which, by being compressed on their surfaces that are in contact, hold the work firmly, and, when the operator desires to have the work moved along, it is only necessary, by having the foot placed in the stirrup, and bearing gently down with the foot, to revolve the cylinder by means of the strap, which act revolves the lower roller *b*, and with it the upper roller, thus feeding the work along. The foot is then raised, when the spring will wind up the strap again upon the cylinder.

The work can be fed along as often and as rapidly as desired, as the pawl in the ratchet holds the cylinder from returning to its original position without winding all the strap on the cylinder that was run off by the bearing on of the foot.

We lay no claim to the cylinder, spring, or feed-rollers by themselves, as they are known to be old and in use; but

What we do claim, and wish to secure by Letters Patent, is—

1. The work-holder herein described, when constructed and arranged to operate in the manner and for the purpose set forth.
2. The stirrup E, constructed in the manner and for the purpose described.
3. The combination of the stirrup E, strap D, cylinder *c*, coiled spring *g*, ratchet *d*, pawl *e*, with the holding and feeding-rollers *b b*, in the manner and for the purpose described.

NICHOLAS CLUTE.
OLIVER W. MARSHALL.

Witnesses:

J. N. SHIPMAN,
C. W. JOHNSON.