

J. CAPRON.

2 Sheets—Sheet 1.

Annunciator.

No. 110,547.

Patented Dec. 27, 1870.

Fig. 1.

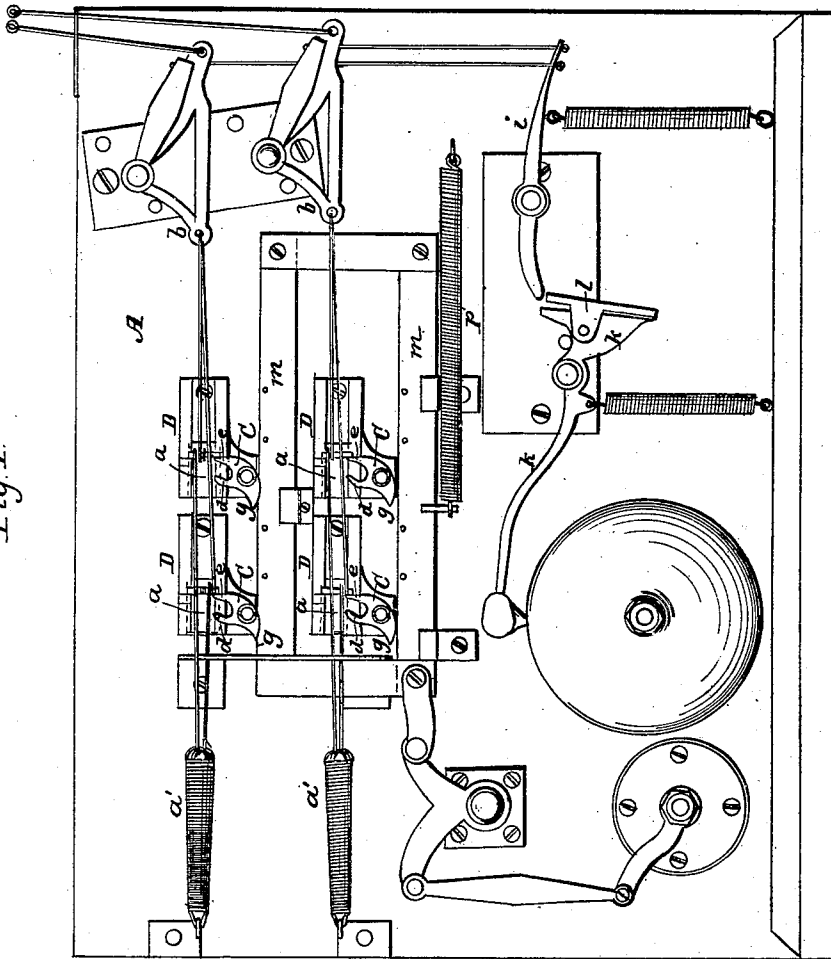

Witnesses:
S. A. Noyes
E. H. Nelson

Inventor:
Jacob Capron by
H. W. Kendall, atty.

J. CAPRON.
Annunciator.

2 Sheets—Sheet 2.

No. 110,547.

Patented Dec. 27, 1870.

Fig. 3.

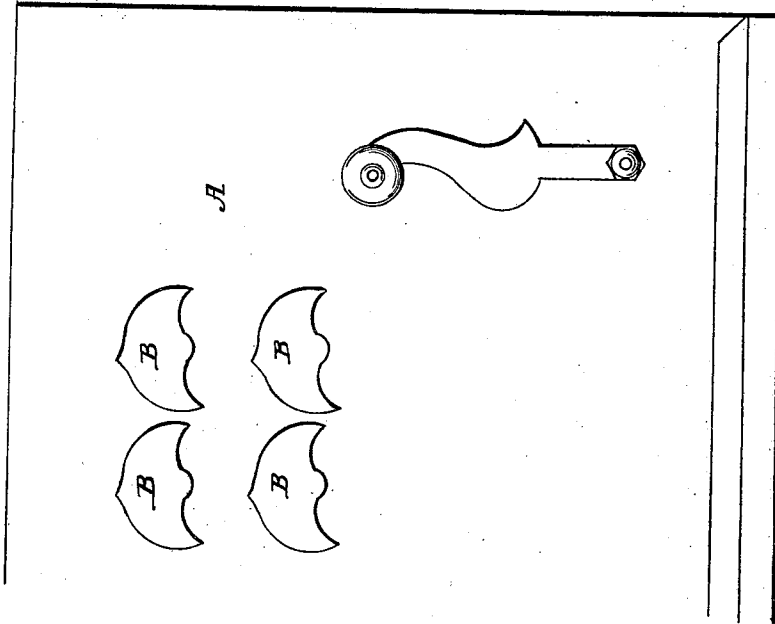
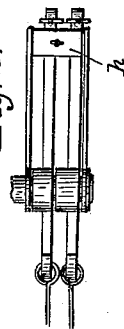

Fig. 2.



Witnesses:
J. A. Jones
J. R. Johnson

Inventor:
Jacob Capron
H. W. Beadle
att'y.

UNITED STATES PATENT OFFICE.

JACOB CAPRON, OF NEW YORK, N. Y.

IMPROVEMENT IN ANNUNCIATORS.

Specification forming part of Letters Patent No. 110,547, dated December 27, 1870.

To all whom it may concern:

Be it known that I, JACOB CAPRON, of New York, in the county of New York and State of New York, have invented new and useful Improvements in Annunciators; and I do hereby declare that the following is a full and exact description of the same, reference being had to the accompanying drawings, and to the letters of reference marked thereon.

This invention relates to improvements in annunciators of the class known as the "Jackson annunciator;" and it consists in certain details of construction which will be fully described hereinafter.

In the drawings, Figure 1, Sheet 1, represents a rear view of the foundation-plate with the various operating parts in place. Fig. 2, Sheet 2, is a plan view of the swinging rack. Fig. 3 represents the face-plates and the crank on the rear of the foundation-plate, which moves the slide returning the tumblers.

The main features shown in the drawings are of the construction known commonly as the "Jackson annunciator," and need not be particularly described.

On the face of the foundation-plate A are the usual numbers forming the register, covered by the face-plates B B, slightly heavier on one side, and connected to the tumblers C C by pins or bolts passing through the foundation-plate.

Fixed to the rear of the foundation-plate at proper distance above the pivots of the tumblers are guides D D, in which move sliding stops *a a*. These stops are connected on the one side to springs *a' a'* and on the other to crank-levers *b b*. They are arranged at such points with relation to the tumblers that when drawn back by the retraction of the spring they will hold the tumblers in the position shown in the figure, and consequently the face-plate elevated and covering the numbers on the register; but when these stops are drawn away from the arms of the tumblers the weight of the face-plates, being greater on that side next the sliding stops, carries the tumblers with the face-plates, in the direction of the motion of the stops to an inverted position, thus leaving the number beneath the said face-plate in each instance exposed to view.

It will be especially observed that the stops are not in any way connected to the tumblers,

which move freely when the stops are drawn away. Any convenient number of these may be arranged in the same horizontal line. The tumblers C C are of peculiar construction, having two arms, *d* and *e*, and a point, *g*. The arm *e* is made straight and rests against the stop. The other arm and point serve purposes which will be hereinafter described. These sliding stops are operated through the crank-levers *b b*, as before stated, by means of ordinary connections. The crank-levers are hung on the same pivot, in number equaling the number of figures on the register and corresponding face-plates. Each has its own separate wire, carried, as usual, to its proper apartment. Over these levers thus hung on one pivot is a rack (shown in Fig. 2) swinging on the same pivot. Its transverse bar *h* rests across the levers in such a manner that the elevation of any lever of the set raises the rack.

From the bar *h* a wire runs to the lever *i*, through which the hammer is operated. It will thus be evident that the raising of any one of the levers, causing the disclosure of a given number, will cause the bell to be struck, while at the same time only one wire is used to connect the bell-lever to the rack. Separate wires may be run to other racks located above.

The lever K, which carries the hammer, is pivoted, as shown, and provided with spring, as usual. Its rear end is enlarged, as shown at K', and has a swinging face, *l*, pivoted by suitable arms therein, and so made and hung as to fall by gravity to the position shown in the drawings. When in this position the end of the lever *i* hangs directly above its upper end. When, however, the other end of this lever is raised by the wire connected thereto, the depressed end strikes the face *l* and carries down with it the enlarged end of the lever, thus raising the hammer. At a proper point, the hammer being raised, the face-piece swings and slips from the end of *i*, allowing the latter to return with itself to the original positions and permitting the hammer to strike freely. The upper part of the enlarged end is slightly cut out and rests against a stop. The tumblers, or any one of them separately, are returned to their proper position, covering with the face-plate the number by means of the sliding frame *m*, which carries pins suitably arranged to strike, when the frame is drawn to

the left, successively upon the bent arm *d* and the point *g*.

The frame is moved by suitable crank and connections, and is drawn back by a spring, *n*.

All the parts are properly fixed and connected to the foundation-plate and the number of face-plates and connections suited to the requirements of the case.

The marked difference between the Jackson annunciator and my improvement is that in the former the stops operate directly upon the face-plate, while in mine they operate upon the tumbler itself without the interposition of a bell-crank.

Having thus fully described my improvements, what I claim as new, and desire to secure by Letters Patent of the United States, is—

The stops *a*, acting directly upon the tumblers, combined with the rotating face-plates, as shown and described.

This specification signed and witnessed this 27th day of May, 1870.

JACOB CAPRON.

Witnesses:

THOS. BARKER,
W. M. POWELL.