

May 9, 1933.

W. E. HUNTER

1,908,496

SELF SUPPORTING PLUMB INDICATOR

Filed Sept. 18, 1931

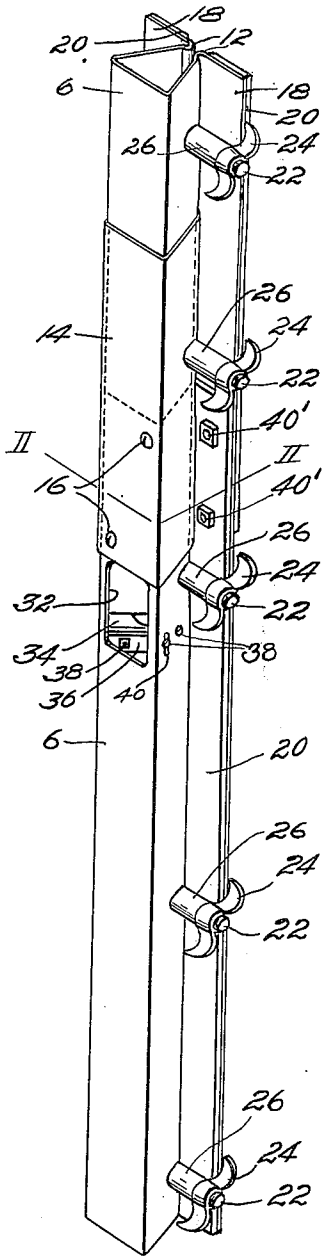

Fig. 1

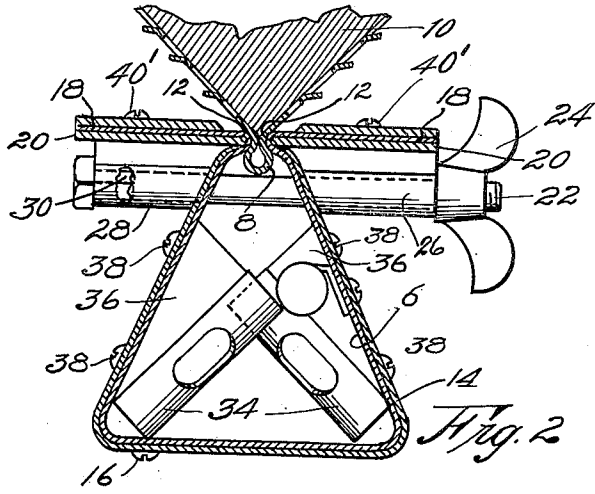

Fig. 2

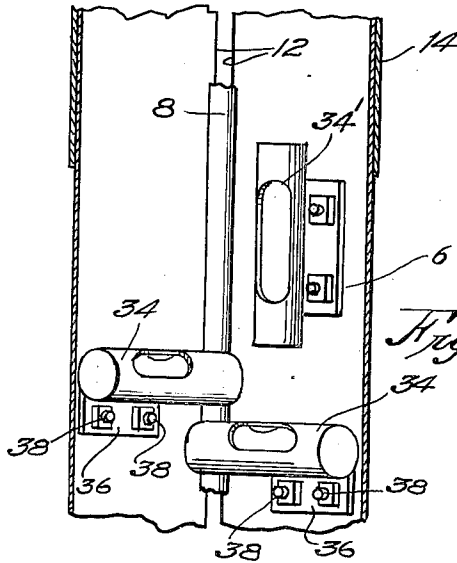

Fig. 3

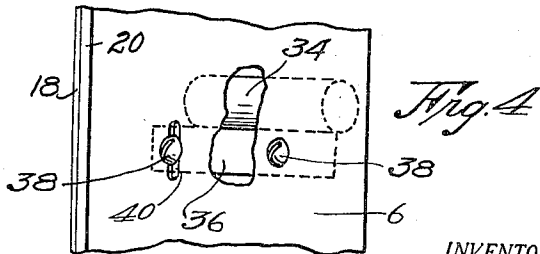

Fig. 4

INVENTOR,
William E. Hunter.
BY
Howe & Hamilton
ATTORNEYS

UNITED STATES PATENT OFFICE

WILLIAM E. HUNTER, OF KANSAS CITY, MISSOURI

SELF-SUPPORTING PLUMB INDICATOR

Application filed September 18, 1931. Serial No. 563,505.

This invention relates to tools of the precision type and the primary object is to provide a plumb indicator for corner reinforcing beads which is easy to operate, quick to position and remove from operative relation with the bead, and efficient, especially with regard to its possibilities of speedy manipulation.

A still further object of this invention is the provision of a builder's tool of the above character which incorporates in its structure a plurality of housed spirit levels, a hollow dove-tailed shaped elongated body, longitudinally extending jaws and means for adjustably interconnecting said jaws, whereby the device may be quickly affixed to the reinforcing bead which is to be attached.

Minor objects of the invention, together with specific details of construction, manner of operation and various uses will appear during the course of the detailed specifications, referring to the accompanying drawing, wherein:

Figure 1 is a perspective view of a self-supporting plumb indicator embodying the features of this invention.

Fig. 2 is an enlarged, horizontal cross section through the same, taken on line II—II of Fig. 1.

Fig. 3 is a fragmentary, vertical section through a portion of the indicator in the proximity of the plurality of spirit levels forming a part of the tool, and,

Fig. 4 is a fragmentary side view of the device illustrating the manner of adjustably supporting some of the spirit levels.

It is well known in this art that reinforcing members which are to be affixed to the corners of structures must be properly applied in a manner which insures their being plumb and in true vertical alinement so that the plaster which is usually applied after the setting of the corner bead will present a plumb and neat appearance. Usually these corner beads are constructed of sheet metal and nailed in place as above mentioned by using a plumbob which insures the projected portion of the bead being in positive vertical position.

termine proper alinement is desirable and obviously this tool must be strong, rugged and susceptible of indicating the proper position of a corner bead throughout its length. A self-supporting plumb indicator for reinforcing beads embodying features of this invention might be constructed to present a pair of elongated body sections 6, each made of sheet metal and formed as shown in Fig. 2 to present in their cross section a dove-tailed shaped member, between the converging walls of which is presented a longitudinal slot for the reception of bead 8 which is to be affixed to a corner member 10. Two co-acting jaws 12 move together and apart when the device is being slipped in place over bead 8.

As illustrated in Fig. 1, the device is made up of two body sections 6, interconnected by sleeve 14, carried by one end of one section 6 and removably secured by screws or analogous means 16 to the other section. When both sections 6 are in longitudinal alinement, sleeve 14 overlaps the joint formed between section 6 so that jaws 12 are continuous throughout the length of both sections.

Sections 6 are alike in so far as the laterally extending flanges 18 are concerned. These flanges project outwardly from along jaws 12 and a reinforcing strip 20 may be used to strengthen flanges 18 after they have been formed integrally with body sections 6. It is notable at this point the jaws 12 are each offset so that they will rest in the groove behind the longitudinal nose of bead 8. Sections 6 are preferably constructed of resilient sheet metal so that when the later described clamping means are released the normal tendency of sections 6 will be to move apart jaws 12.

While there may be many means provided for adjustably clamping together jaws 12, the expedient herein described and illustrated in the drawing has been found advantageous. A plurality of bolts 22 extend from one flange 18 to the other through body sections 6 so that the turning of winged nut 24 on each bolt 22 respectively will securely clamp bead 8 between jaws 12. To hold the bolts 22 in place there should be provided a

The use of a quickly attachable tool to de-

bearing 26 on one flange 18 and a similar bearing 28 on the other flange opposite each bearing 26. All bolts 22 are squared as at 30 to fit into a similarly squared opening in bearing 28. This form of construction insures that bolt 22 will remain stationary while nut 24 is being turned.

A plurality of spirit levels housed within hollow body sections 6 adjacent a window 32 indicate the alinement of bead 8 as it is being affixed to member 10. This plurality of spirit levels includes the two normally horizontal ones 34 and the normally vertical one 34. Each spirit level is secured to one of the converging side walls of the dove-tailed shaped body section 6 and, in the case of spirit levels 34, a small bracket 36 is used to be engaged by a bolt 38 at each end respectively of bracket 36. Lever 34 is employed when the tool is used as means for leveling a horizontally disposed bead or building unit.

As illustrated in Fig. 4, when setting spirit levels 34, it is desirable to alter the relative position with respect to their accurate angularity to jaws 12. To provide for this point of the invention, the structure supplies a slot 40, through which passes one of bolts 38 so that a tilting of the spirit level 34 about the other bolt 38 may be accomplished. Reference to Fig. 2 will readily teach that spirit levels should have their longitudinal axis in a plane parallel to the plane of corner member 10 and also the sides of corner bead 8. The combined action of these three spirit levels will permit of placing a bead 8 in a true plumb and vertical position.

After the device has been affixed to bead 8, the same may be used to easily handle the bead to draw it toward or from the corner member 10 to which it is being affixed. After securing bead 8 in place, nuts 24 are loosened and jaws 12 snapped off of the nose portion of bead 8. This action leaves the device in proper position for replacement without attention to the securing means. The resiliency of the material from which the body sections 6 are constructed allows a snapping into place without further attention to bolts 22.

The positioning of bolts 22 so that they pass through body sections 6 behind bead 8 and intermediate this bead and the third wall of the dove-tailed shaped body is an advantage in that it matters not how tightly the securing bolts and nuts are drawn distortion will not take place. As may be seen in Fig. 1, reinforcing strip 20 of one section overlaps the reinforcing strip 20 of the other section and screws 40' are utilized to interconnect these overlapping members. This position of these parts adds even further strength to the assembly.

Having thus described the invention, what is claimed as new and desired to be secured by Letters Patent is:

1. A plumb indicator for corner beads comprising an elongated body; a pair of opposed longitudinal jaws formed by said body for engaging the bead; a plurality of spirit levels being disposed at substantially a right angle to each other in parallel horizontal planes and housed within said body; and means to clamp together said jaws, certain of said levels converging toward each other.

2. A plumb indicator for corner beads comprising an elongated hollow body; a pair of opposed longitudinal jaws formed by said body for engaging the bead; a plurality of spirit levels being within said body at substantially a right angle to each other in parallel horizontal planes; and clamping means for said jaws extending transversely thereof from one to the other through said elongated hollow body, certain of said spirit levels converging.

3. A plumb indicator for corner beads comprising an elongated hollow body; a pair of jaws formed by said body for engaging the bead; a plurality of spirit levels within the body; oppositely extending flanges integral with said body and coextensive with said jaws; and clamping means for said jaws passing through said body to adjustably interconnect said flanges.

4. A plumb indicator for corner beads comprising an elongated hollow body of dove-tail cross section having an opening forming a pair of coextensive longitudinal jaws along the converging sides of said body to engage the bead; a plurality of spirit levels within the body; and a plurality of clamping means passing transversely through the body whereby to draw together said jaws, certain of said levels being in parallel relation to the walls forming the corner.

5. A plumb indicator for corner beads comprising a continuous, hollow, sheet metal, sectional body having an entrance slot between two opposing side walls thereof; a sleeve bridging the joint between said sections; a plurality of clamping means passing transversely through said body whereby to draw together opposing sides of said body; a plurality of spirit levels within the body; and laterally projecting flanges coextensive with the body, said clamping means being supported by said flanges.

6. In a plumb indicator for corner beads, a hollow body of dove-tail cross section, a plurality of spirit levels being within said body at substantially a right angle to each other in parallel horizontal planes; and means adjustably supporting each of said levels in the operative position, said levels including a pair of spirit levels disposed to converge toward each other, said levels being in substantially parallel relation to the walls forming the corners when the indicator is in the operative position.

7. In a plumb indicator of the class de-

scribed, a hollow body of dove-tail cross section having a pair of converging sides; a pair of coextensive jaws formed by said converging sides; a laterally projecting flange
5 integral with each wall along the jaw-forming edge thereof; and a plurality of bolts extending through said body from flange to flange to draw together said jaws.

8. In a plumb indicator of the class described, a hollow body of dove-tail cross section having a pair of converging sides; a pair of coextensive jaws formed by said converging sides; a laterally projecting flange integral with each wall along the jaw-forming
15 edge thereof; squared bearings on one of said flanges; and a plurality of bolts extending through said body from flange to flange to draw together said jaws, each of said bolts
20 having a squared portion engaging one of said squared bearings supported by one of said flanges.

In testimony whereof, I hereunto affix my signature.

WILLIAM E. HUNTER.

25

30

35

40

45

50

55

60

65