

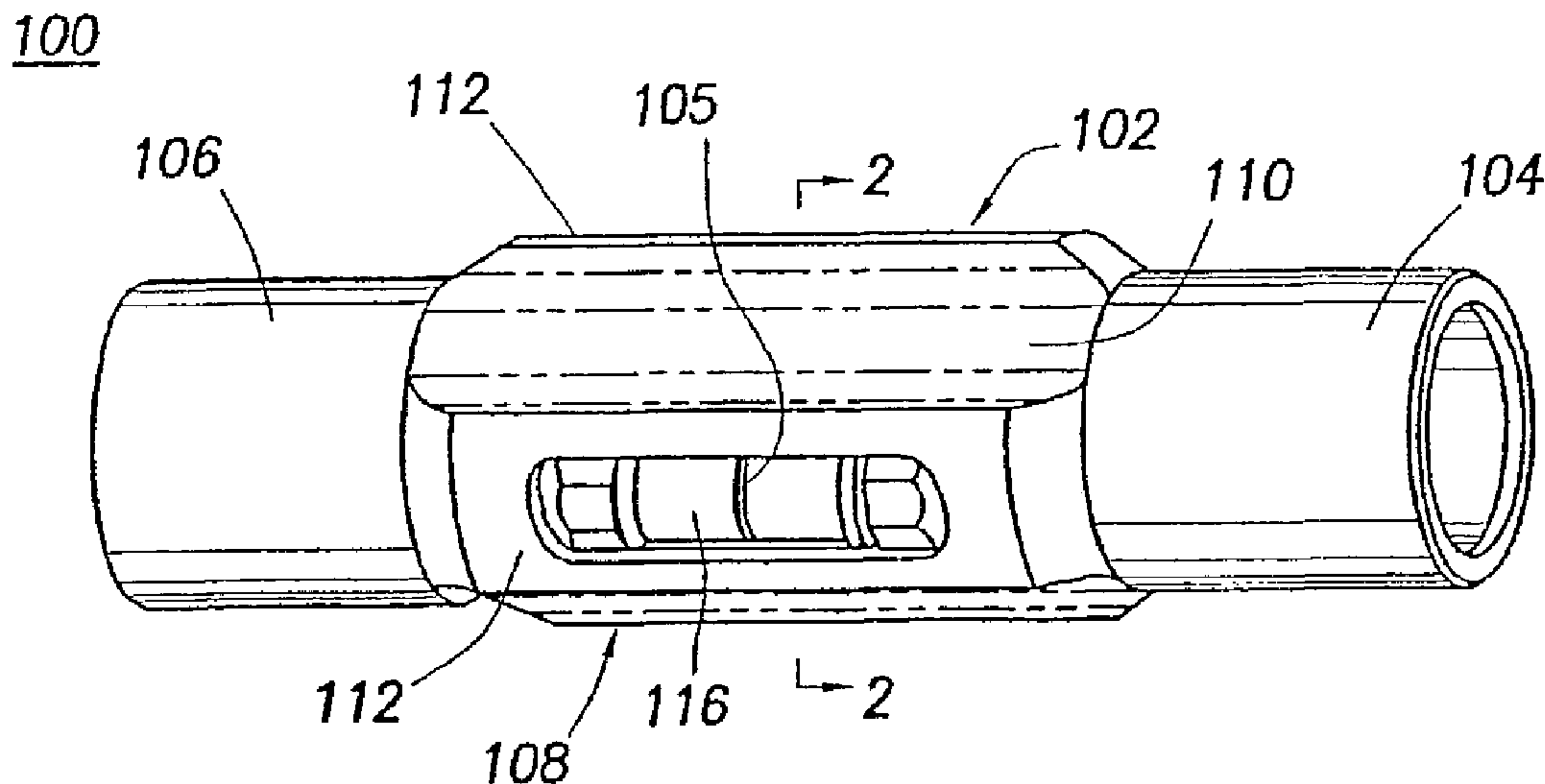

(22) Date de dépôt/Filing Date: 2001/11/08  
 (41) Mise à la disp. pub./Open to Public Insp.: 2002/05/16  
 (45) Date de délivrance/Issue Date: 2007/03/20  
 (62) Demande originale/Original Application: 2 428 479  
 (30) Priorité/Priority: 2000/11/13 (US09/712,789)

(51) Cl.Int./Int.Cl. *E21B 29/00* (2006.01),  
*E21B 17/00* (2006.01), *E21B 33/04* (2006.01)  
 (72) Inventeurs/Inventors:  
SIMPSON, NEIL ANDREW ABERCROMBIE, GB;  
TRAHAN, KEVIN OTTO, US  
 (73) Propriétaire/Owner:  
WEATHERFORD/LAMB, INC., US  
 (74) Agent: MARKS & CLERK

(54) Titre : APPAREIL ET PROCEDES PERMETTANT DE SEPARER ET DE RELIER DES ELEMENTS TUBULAIRES  
DANS UN PUIT DE FORAGE  
 (54) Title: APPARATUS AND METHODS FOR SEPARATING AND JOINING TUBULARS IN A WELLBORE



(57) **Abrégé/Abstract:**

The present invention provides methods and apparatus for cutting tubulars in a wellbore. In one aspect of the invention, a cutting tool having radially disposed rolling element cutter is provided for insertion into a wellbore to a predetermined depth where a tubular therearound will be cut into an upper and lower portion. The cutting tool is constructed and arranged to be rotated while the actuated cutters exert a force on the inside wall of the tubular, thereby severing the tubular therearound. In one aspect, the apparatus is run into the well on wireline which is capable of bearing the weight of the apparatus while supplying a source of electrical power to at least one downhole motor which operates at least one hydraulic pump. The hydraulic pump operates a slip assembly to fix the downhole apparatus within the wellbore prior to operation of the cutting tool. Thereafter, the pump operates a downhole motor to rotate the cutting tool while the cutters are actuated.

**ABSTRACT**

The present invention provides methods and apparatus for cutting tubulars in a wellbore. In one aspect of the invention, a cutting tool having radially disposed rolling element cutter is provided for insertion into a wellbore to a predetermined depth where a tubular therearound will be cut into an upper and lower portion. The cutting tool is constructed and arranged to be rotated while the actuated cutters exert a force on the inside wall of the tubular, thereby severing the tubular therearound. In one aspect, the apparatus is run into the well on wireline which is capable of bearing the weight of the apparatus while supplying a source of electrical power to at least one downhole motor which operates at least one hydraulic pump. The hydraulic pump operates a slip assembly to fix the downhole apparatus within the wellbore prior to operation of the cutting tool. Thereafter, the pump operates a downhole motor to rotate the cutting tool while the cutters are actuated.

**Apparatus And Methods For Separating And  
Joining Tubulars in a Wellbore**

This is a divisional application of Canadian Patent Application Serial No. 2,428,479 filed on November 8, 2001.

5           The present invention relates to methods and apparatus for separating and joining tubulars in a wellbore; more particularly, the present invention relates to cutting a tubular in a wellbore using rotational and radial forces brought to bear against a wall of the tubular. It should be understood that the expression "the invention" and the like encompasses the subject matter of both the parent and divisional applications.

10           In the completion and operation of hydrocarbon wells, it is often necessary to separate one piece of a downhole tubular from another piece in a wellbore. In most instances, bringing the tubular back to surface for a cutting operation is impossible and in all instances it is much more efficient in time and money to separate the pieces in the wellbore. The need to separate tubulars in a wellbore arises in different ways. For  
15           example, during drilling and completion of an oil well, tubulars and downhole tools mounted thereon are routinely inserted and removed from the wellbore. In some instances, tools or tubular strings become stuck in the wellbore leading to a "fishing" operation to locate and remove the stuck portion of the apparatus. In these instances, it is often necessary to cut the tubular in the wellbore to remove the run-in string and  
20           subsequently remove the tool itself by milling or other means. In another example, a downhole tool such as a packer is run into a wellbore on a run-in string of tubular. The packing member includes a section of tubular or a "tail pipe" hanging from the bottom thereof and it is advantageous to remove this section of tail pipe in the wellbore after the packer has been actuated. In instances where workover is necessary for a well which has  
25           slowed or ceased production, downhole tubulars routinely must be removed in order to replace them with new or different tubulars or devices. For example, un-cemented well casing may be removed from a well in order to reuse the casing or to get it out of the way in a producing well.

          In yet another example, plug and abandonment methods require tubulars to be cut  
30           in a wellbore such as a subsea wellbore in order to seal the well and conform with rules and regulations associated with operation of an oil well offshore. Because the interior of a tubular typically provides a pathway clear of obstructions, and because any

annular space around a tubular is limited, prior art devices for downhole tubular cutting typically operate within the interior of the tubular and cut the wall of the tubular from the inside towards the outside.

5           A prior art example of an apparatus designed to cut a tubular in this fashion includes a cutter run into the interior of a tubular on a run-in string. As the tool reaches a predetermined area of the wellbore where the tubular will be separated, cutting members in the cutting tool are actuated hydraulically and swing outwards from a pivot point on the body of the tool. When the cutting members are actuated, the run-in string  
10 with the tool therebelow is rotated and the tubular therearound is cut by the rotation of the cutting members. The foregoing apparatus has some disadvantages. For instance, the knives are constructed to swing outward from a pivot point on the body of the cutting tool and in certain instances, the knives can become jammed between the cutting tool and the interior of the tubular to be cut. In other instances, the cutting members can  
15 become jammed in a manner which prevents them from retracting once the cutting operation is complete. In still other examples, the swinging cutting members can become jammed with the lower portion of tubular after it has been separated from the upper portion thereof. Additionally, this type of cutter creates cuttings that are difficult to remove and subsequently causes problems for other downhole tools.

20           An additional problem associated conventional downhole cutting tools includes the cost and time associated with transporting a run-in string of tubular to a well where a downhole tubular is to be cut. Run-in strings for the cutting tools are expensive, must be long enough to reach that section of downhole tubular to be cut, and require some  
25 type of rig in order to transport, bear the weight of, and rotate the cutting tool in the wellbore. Because the oil wells requiring these services are often remotely located, transporting this quantity of equipment to a remote location is expensive and time consuming. While coil tubing has been utilized as a run-in string for downhole cutters, there is still a need to transport the bulky reel of coil tubing to the well site prior to  
30 performing the cutting operation.

Other conventional methods and apparatus for cutting tubulars in a wellbore rely upon wireline to transport the cutting tool into the wellbore. However, in these instances the actual separation of the downhole tubular is performed by explosives or chemicals, not by a rotating cutting member. While the use of wireline in these methods avoids time and expense associated with run-in strings of tubulars or coil tubing, chemicals and explosives are dangerous, difficult to transport and the result of their use in a downhole environment is always uncertain.

There is a need therefore, for a method and apparatus for separating downhole tubulars which is more effective and reliable than conventional, downhole cutters. There is yet a further need for an effective method and apparatus for separating downhole tubulars which does not rely upon a run-in string of tubular or coil tubing to transport the cutting member into the wellbore. There is yet a further need for a method and apparatus of separating downhole tubulars which does not rely on explosives or chemicals. There is a yet a further need for methods and apparatus for connecting a first tubular to a second tubular downhole while ensuring a strong connection therebetween.

The present invention provides methods and apparatus for cutting tubulars in a wellbore. In one aspect of the invention, a cutting tool having radially disposed rolling element cutters is provided for insertion into a wellbore to a predetermined depth where a tubular therearound will be cut into an upper and lower portion. The cutting tool is constructed and arranged to be rotated while the actuated cutters exert a force on the inside wall of the tubular, thereby severing the tubular therearound. In one aspect, the apparatus is run into the well on wireline which is capable of bearing the weight of the apparatus while supplying a source of electrical power to at least one downhole motor which operates at least one hydraulic pump. The hydraulic pump operates a slip assembly to fix the downhole apparatus within the wellbore prior to operation of the cutting tool. Thereafter, the pump operates a downhole motor to rotate the cutting tool while the cutters are actuated.

30

In another aspect of the invention, the cutting tool is run into the wellbore on a run-in string of tubular. Fluid power to the cutter is provided from the surface of the

well and rotation of the tool is also provided from the surface through the tubular string. In another aspect, the cutting tool is run into the wellbore on pressurizable coiled tubing to provide the forces necessary to actuate the cutting members and a downhole motor providing rotation to the cutting tool.

5

In another aspect of the invention, the apparatus includes a cutting tool having hydraulically actuated cutting members, a fluid filled pressure compensating housing, a torque anchor section with hydraulically deployed slips, a brushless dc motor with a source of electrical power from the surface, and a reduction gear box to step down the  
10 motor speed and increase the torque to the cutting tool, as well as one or more hydraulic pumps to provide activation pressure for the slips and the cutting tool. In operation, the anchor activates before the rolling element cutters thereby allowing the tool to anchor itself against the interior of the tubular to be cut prior to rotation of the cutting tool. Hydraulic fluid to power the apparatus is provided from a pressure compensated  
15 reservoir. As oil is pumped into the actuated portions of the apparatus, the compensation piston moves downward to take up space of used oil.

In yet another aspect of the invention, an expansion tool and a cutting tool are both used to affix a tubular string in a wellbore. In this embodiment, a liner is run into a  
20 wellbore and is supported by a bearing on a run-in string. Disposed on the run-in string, inside of an upper portion of the liner is a cutting tool and therebelow an expansion tool. As the apparatus reaches a predetermined location of the wellbore, the expander is actuated hydraulically and the liner portion therearound is expanded into contact with the casing therearound. Thereafter, with the weight of the liner transferred from the  
25 run-in string to the newly formed joint between the liner and the casing, the expander is de-actuated and the cutter disposed thereabove on the run-in string is actuated. The cutter, through axial and rotational forces, separates the liner into an upper and lower portion. Thereafter, the cutter is de-actuated and the expander therebelow is re-actuated. The expansion tool expands that portion of the liner remaining thereabove and  
30 is then de-actuated. After the separation and expanding operations are complete, the run-in string, including the cutter and expander are removed from the wellbore, leaving

the liner in the wellbore with a joint between the liner and the casing therearound sufficient to fix the liner in the wellbore.

In yet another aspect, the invention provides apparatus and methods to join  
5 tubulars in a wellbore providing a connection therebetween with increased strength that facilitates the expansion of one tubular into another.

According to an aspect of the invention there is provided a method of cutting a  
tubular in a wellbore comprising:

10 expanding at least a portion of the tubular in the wellbore;  
conveying a cutting member into the wellbore;  
separating the tubular into a first section and a second section;  
removing the first section from the wellbore.

15 According another aspect of the invention there is provided a tool string for cutting and expanding a tubular in a wellbore, comprising:

a cutting tool disposed on the tool string, the cutting tool configured for transversely severing the tubular; and  
an expansion tool disposed on the tool string.

20

According to a further aspect of the invention there is provided a method of expanding and cutting a tubular in a wellbore, comprising:

running an apparatus into the wellbore, the apparatus including a cutter and an expander disposed on a run-in string;  
25 operating the expander to expand a portion of the tubular; and  
operating the cutter to sever transversely the tubular.

According to a further aspect of the invention there is provided a method of cutting a tubular in a wellbore, comprising:

30 disposing at least a portion of the tubular in a larger diameter tubular;  
providing a cutting apparatus having an extendable cutting member;  
extending the cutting member into contact with the tubular; and

5a

rotating the cutting apparatus to deform the tubular, the degree of deformation being such that the tubular is cut; and  
expanding the tubular.

5           According to a further aspect of the invention there is provided a method of cutting a section of tubing in a borehole, comprising:  
providing a cutting device having at least one radially movable piston that includes a cutter;  
positioning the device in the borehole adjacent a tubular in the borehole;  
10          supplying fluid pressure through a conduit to an internal portion of the cutting device, thereby extending the piston such that at least a portion of the cutter contacts the tubular;  
and  
rotating the cutting device to deform the tubular, the degree of deformation being such that the tubular is cut.

15           So that the manner in which the above recited features, advantages and objects of the present invention are attained and can be understood in detail, a more particular description of the invention, briefly summarized above, may be had by reference to the embodiments thereof which are illustrated in the appended drawings.

20           It is to be noted, however, that the appended drawings illustrate only typical embodiments of this invention and are therefore not to be considered limiting of its scope, for the invention may admit to other equally effective embodiments. In the drawings:

25           **Figure 1 is a perspective view of the cutting tool of the present invention.**

**Figure 2 is a perspective end view in section, thereof.**

**Figure 3 is an exploded view of the cutting tool.**

30           **Figure 4 is a section view of the cutting tool disposed in a wellbore at the end of a run-in string and having a tubular therearound.**

5b

Figure 5 is a section view of the apparatus of Figure 4, wherein cutters are actuated against the inner wall of the tubular therearound.

Figure 6 is a view of a well, partially in section, illustrating a cutting tool and a  
5 mud motor disposed on coil tubing.

Figure 7 is a section view of a wellbore illustrating a cutting tool, mud motor and tractor disposed on coil tubing.

Figure 8 is a section view of an apparatus including a cutting tool, motor/pump  
5 and slip assembly disposed on a wireline.

Figure 9 is a section view of the apparatus of Figure 6, with the cutting tool and a slip assembly actuated against the inner wall of a tubular therearound.

10 Figure 10 is a section view of a liner hanger apparatus including a liner portion, and run-in string with a cutting tool and an expansion tool disposed thereon.

Figure 11 is an exploded view of the expansion tool.

15 Figure 12 is a section view of the liner hanger apparatus of Figure 8 illustrating a section of the liner having been expanded into the casing therearound by the expansion tool.

20 Figure 13 is a section view of the liner hanger apparatus with the cutting tool actuated in order to separate the liner therearound into an upper and lower portion.

Figure 14 is a section view of the liner hanger apparatus with an additional portion of the liner expanded by the expansion tool.

25 Figure 15 is a perspective view of a tubular for expansion into and connection to another tubular.

Figure 16 is the tubular of Figure 15 partially expanded into contact with an outer tubular.

30

Figure 17 is the tubular of Figure 16 fully expanded into the outer tubular with a seal therebetween.

Figure 18 is an alternative embodiment of a tubular for expansion into and in connection to another tubular.

5 Figure 19 is a section view of the tubular of Figure 18 with a portion thereof expanded into a larger diameter tubular therearound and illustrating a fluid path of fluid through an annulus area.

10 Figure 20 is a section view of the tubular of Figure 18 completely expanded into the larger diameter tubular therearound.

Figures 1 and 2 are perspective views of the cutting tool 100 of the present invention. Figure 3 is an exploded view thereof. The tool 100 has a body 102 which is hollow and generally tubular with conventional screw-threaded end connectors 104 and 15 106 for connection to other components (not shown) of a downhole assembly. The end connectors 104 and 106 are of a reduced diameter (compared to the outside diameter of the longitudinally central body part 108 of the tool 100), and together with three longitudinal flutes 110 on the central body part 108, allow the passage of fluids between the outside of the tool 100 and the interior of a tubular therearound (not shown). The 20 central body part 108 has three lands 112 defined between the three flutes 110, each land 112 being formed with a respective recess 114 to hold a respective roller 116. Each of the recesses 114 has parallel sides and extends radially from the radially perforated tubular core 115 of the tool 100 to the exterior of the respective land 112. Each of the mutually identical rollers 116 is near-cylindrical and slightly barreled with a 25 single cutter 105 formed thereon. Each of the rollers 116 is mounted by means of a bearing 118 (Figure 3) at each end of the respective roller for rotation about a respective rotation axis which is parallel to the longitudinal axis of the tool 100 and radially offset therefrom at 120-degree mutual circumferential separations around the central body 108. The bearings 118 are formed as integral end members of radially slidable pistons 30 120, one piston 120 being slidably sealed within each radially extended recess 114. The inner end of each piston 120 (Figure 2) is exposed to the pressure of fluid within the hollow core of the tool 100 by way of the radial perforations in the tubular core 115.

By suitably pressurizing the core 115 of the tool 100, the pistons 120 can be driven radially outwards with a controllable force which is proportional to the pressurization, and thereby the rollers 116 and cutters 105 can be forced against the inner wall of a tubular in a manner described below. Conversely, when the  
5 pressurization of the core 115 of the tool 100 is reduced to below whatever is the ambient pressure immediately outside the tool 100, the pistons 120 (together with the piston-mounted rollers 116) are allowed to retract radially back into their respective recesses 114.

10

Figure 4 is a section view of the cutting tool 100 disposed at the end of a tubular run-in string 101 in the interior of a tubular 150. In the embodiment shown, the tubular 150 is a liner portion functioning to line a borehole. However, it will be understood that the cutting tool 100 could be used to sever any type of tubular in a wellbore and the invention is not limited to use with a tubular lining the borehole of a well. The run-in  
15 string 101 is attached to a first end connector 106 of the cutting tool 100 and the tool is located at a predetermined position within the tubular 150. With the cutting tool 100 positioned in the tubular 150, a predetermined amount of fluid pressure is supplied through the run-in string 101. The pressure is adequate to force the pistons 120 and the  
20 rollers 116 with their cutters 105 against the interior of the tubular. With adequate force applied, the run-in string 101 and cutting tool 100 are rotated in the tubular, thereby causing a groove of ever increasing depth to be formed around the inside of the tubular 150. Figure 5 is a section view of the apparatus of Figure 4 wherein the rollers 116 with their respective cutters 105 are actuated against the inner surface of the tubular 150.  
25 With adequate pressure and rotation, the tubular is separated into an upper 150a and lower 150b portions. Thereafter, with a decrease in fluid pressure, the rollers 116 are retracted and the run-in string 101 and cutting tool 100 can be removed from the wellbore.

30

Figure 6 illustrates an alternative embodiment of the invention including a cutting tool 100 disposed in a wellbore 160 on a run-in string 165 of coil tubing. A mud motor 170 is disposed between the lower end of the coil tubing string 165 and the

cutting tool 100 and provides rotational force to the tool 100. In this embodiment, pressurized fluid adequate to actuate the rollers 116 with their cutters 105 is provided in the coil tubing string 165. The mud motor 170 is also operated by fluid in the coil tubing string 165 and an output shaft of the mud motor is coupled to an input shaft of the cutting tool 100 to provide rotation to the cutting tool 100. Also illustrated in Figure 6 is a coil tubing reel 166 supplying tubing which is run into the wellbore 160 through a conventional wellhead assembly 168. With the use of appropriate known pressure containing devices, the cutting tool 100 can be used in a live well.

Figure 7 is a section view illustrating a cutting tool 100 disposed on coil tubing 165 in a wellbore 160 with a mud motor 170 and a tractor 175 disposed thereabove. As in the embodiment of Figure 6, the cutting tool 100 receives a source of pressurized fluid for actuation from the coil tubing string 165 thereabove. The mud motor 170 provides rotational force to the cutter. Additionally, the tractor 175 provides axial movement necessary to move the cutting tool assembly in the wellbore. The tractor is especially useful when gravity alone would not cause the necessary movement of the cutting tool 100 in the wellbore 160. Axial movement can be necessary in order to properly position the cutting tool 100 in a non-vertical wellbore, like a horizontal wellbore. Tractor 175, like the cutting tool includes a number of radially actuatable rollers 176 that extend outward to contact the inner wall of a tubular 150 therearound. The spiral arrangement of the rollers 176 on the body 177 of the tractor 175 urge the tractor axially when rotational force is applied to the tractor body 177.

Figure 8 is a section view of an apparatus 200 including the cutting tool 100 disposed in a tubular 150 on wireline 205. In use, the apparatus 200 is run into a wellbore on wireline extending from the surface of the well (not shown). The wireline 205 serves to retain the weight of the apparatus 200 and also provide a source of power electrical to components of the apparatus. The apparatus 200 is designed to be lowered to a predetermined depth in a wellbore where a tubular 150 therearound is to be separated. Included in the apparatus 200 is a housing 210 having a fluid reservoir 215 with a pressure compensating piston (not shown), a hydraulically actuated slip assembly 220 and a cutting tool 100 disposed below the housing 210. The pressure compensating

piston 215 allows fluid in the reservoir 215 to expand and contract with changes in pressure and isolates the fluid in the reservoir fluid from wellbore fluid therearound. Disposed between the slip assembly 220 and the cutting tool 100 is a brushless dc motor 225 powering two reciprocating hydraulic pumps 230, 235 and providing rotational  
5 movement to the cutter tool 100. Each pump is in fluid communication with reservoir 215. The upper pump 230 is constructed and arranged to provide pressurized fluid to the slip assembly 220 in order to cause slips to extend outwardly and contact the tubular 150 therearound. The lower pump 235 is constructed and arranged to provide pressurized fluid to the cutting tool 100 in order to actuate rollers 116 and cutters 105  
10 and force them into contact with the tubular 150 therearound. A gearbox 240 is preferably disposed between the output shaft of the motor and the rotational shaft of the cutting tool. The gearbox 240 functions to provide increased torque to the cutting tool 100. The pumps 230, 235 are preferably axial piston, swash plate-type pumps having axially mounted pistons disposed alongside the swash plate. The pumps are designed to  
15 alternatively actuate the pistons with the rotating swash plate, thereby providing fluid pressure to the components. However, either pump 230, 235 could also be a plain reciprocating, gear rotor or spur gear-type pump. The upper pump, disposed above the motor 225, preferably runs at a higher speed than the lower pump ensuring that the slip assembly 220 will be actuated and will hold the apparatus 200 in a fixed position  
20 relative to the tubular 150 before the cutters 105 contact the inside wall of the tubular. The apparatus 200 will thereby anchor itself against the inside of the tubular 150 to permit rotational movement of the cutting tool 100 therebelow.

Hydraulic fluid to power the both the upper 230 and lower 235 pumps is  
25 provided from the pressure compensated reservoir 215. As fluid is pumped behind a pair of slip members 245a, 245b located on the slip assembly 220, the compensation piston will move in order to take up space of the fluid as it is utilized. Likewise, the rollers 116 of the cutting tool 100 operate on pressurized fluid from the reservoir 215.

30 The slip members 245a, 245b and the radially slidable pistons 120 housing the rollers 116 and cutters 105 preferably have return springs installed therebehind which will urge the pistons 245a, 245b, 120 to a return or a closed position when the power is

removed and the pumps 230, 235 have stopped operating. Residual pressure within the system is relieved by means of a control orifice or valves in the supply line (not shown) to the pistons 245a, 245b, 120 of the slip assembly and the cutting tool 100. The valves or controlled orifices are preferably set to dump oil at a much lower rate than the pump output. In this manner, the apparatus of the present invention can be run into a wellbore to a predetermined position and then operated by simply supplying power from the surface via the wireline 205 in order to fix the apparatus 200 in the wellbore and cut the tubular. Finally, after the tubular 150 has been severed and power to the motor 225 has been removed, the slips 246a, 246b and cutters 105 will de-actuate with the slips 246a, 246b and the cutters 105 returning to their respective housings, allowing the apparatus 200 to be removed from the wellbore.

Figure 9 is a section view of the apparatus 200 of Figure 9 with the slip assembly 220 actuated and the cutting tool 100 having its cutting surfaces 105 in contact with the inside wall of the tubular 150. In operation, the apparatus 200 is run into the wellbore on a wireline 205. When the apparatus reaches a predetermined location in the wellbore or within some tubular therein to be severed, power is supplied to the brushless dc motor 225 through the wireline 205. The upper pump 230, running at a higher speed than the lower pump 235, operates the slip assembly 220 causing the slips 246a, 246b to actuate and grip the inside surface of the tubular 150. Thereafter, the lower hydraulic pump 235 causes the cutters 105 to be urged against the tubing 150 at that point where the tubing is to be severed and the cutting tool 100 begins to rotate. Through rotation of the cutting tool 100 and radial pressure of the cutters 105 against the inside wall of the tubular 150, the tubular can be partially or completely severed and an upper portion 150a of the tubing separated from a lower portion 150b thereof. At the completion of the operation, power is shut off to the apparatus 200 and through a spring biasing means, the cutters 105 are retracted into the body of the cutting tool 100 and the slips 246a, 246b retract into the housing of the slip assembly 220. The apparatus 200 may then be removed from the wellbore. In an alternative embodiment, the slip assembly 220 can be caused to stay actuated whereby the upper portion 150a of the severed tubular 150 is carried out of the well with the apparatus 200.

Figure 10 is a section view showing another embodiment of the invention. In this embodiment, an apparatus 300 for joining downhole tubulars and then severing a tubular above the joint is provided. The apparatus 300 is especially useful in fixing or hanging a tubular in a wellbore and utilizes a smaller annular area than is typically  
5 needed for this type operation. The apparatus 300 includes a run-in tubular 305 having a cutting tool 100 and an expansion tool 400 disposed thereon.

Figure 11 is an exploded view of the expansion tool. The expansion tool 400, like the cutting tool 100 has a body 402 which is hollow and generally tubular with  
10 connectors 404 and 406 for connection to other components (not shown) of a downhole assembly. The end connectors 404 and 406 are of a reduced diameter (compared to the outside diameter of the longitudinally central body 402 of the tool 400), and together with three longitudinal flutes 410 on the body 402, allow the passage of fluids between the outside of the tool 400 and the interior of a tubular therearound (not shown). The  
15 body 402 has three lands 412 defined between the three flutes 410, each land 412 being formed with a respective recess 414 to hold a respective roller 416. Each of the recesses 414 has parallel sides and extends radially from the radially perforated tubular core 415 of the tool 400 to the exterior of the respective land 412. Each of the mutually identical rollers 416 is near-cylindrical and slightly barreled. Each of the rollers 416 is mounted  
20 by means of a bearing 418 at each end of the respective roller for rotation about a respective rotation axis which is parallel to the longitudinal axis of the tool 400 and radially offset therefrom at 120-degree mutual circumferential separations around the central body 408. The bearings 418 are formed as integral end members of radially slidable pistons 420, one piston 420 being slidably sealed within each radially extended  
25 recess 414. The inner end of each piston 420 is exposed to the pressure of fluid within the hollow core of the tool 400 by way of the radial perforations in the tubular core 415 (Figure 10).

Referring again to Figure 10, also disposed upon the run-in string and supported  
30 thereon by a bearing member 310 is a liner portion 315 which is lowered into a wellbore along with the apparatus 300 for installation therein. In the embodiment shown in Figure 10, the bearing member 310 supports the weight of the liner portion 315 and

permits rotation of the run-in string independent of the liner portion 315. The liner 315 consists of tubular having a first, larger diameter portion 315a which houses the cutting tool 100 and expansion tool 400 and a tubular of a second, small diameter 315b therebelow. One use of the apparatus 300 is to fix the liner 315 in existing casing 320  
5 by expanding the liner into contact with the casing and thereafter, severing the liner at a location above the newly formed connection between the liner 315 and the casing 320.

Figure 12 is a section view of the apparatus 300 illustrating a portion of the larger diameter tubular 315a having been expanded into casing 320 by the expanding  
10 tool 400. As is visible in the Figure, the expanding tool 400 is actuated and through radial force and axial movement, has enlarged a given section of the tubular 315a therearound once the tubular 315 is expanded into the casing 325, the weight of the liner 315 is borne by the casing 325 therearound, and the run-in string 305 with the expanding 400 and cutting 105 tools can independently move axially within the  
15 wellbore. Preferably, the tubular 315 and casing 325 are initially joined only in certain locations and not circumferentially. Consequently, there remains a fluid path between the liner and casing and any cement to be circulated in the annular area between the casing 325 and the outside diameter of the liner 315 can be introduced into the wellbore 330.

20

Figure 13 is a section view of the apparatus 300 whereby the cutting tool 100 located on the run-in string 305 above the expansion tool 400 and above that portion of the liner which has been expanded, is actuated and the cutters 105, through rotational and radial force, separate the liner into an upper and lower portion. This step is  
25 typically performed before any circulated cement has cured in the annular area between the liner 315 and casing 320. Finally, Figure 14 depicts the apparatus 300 of the present invention in the wellbore after the liner 315 has been partially expanded, severed and separated into an upper and lower portion and the upper portion of the expanded liner 315 has been "rolled out" to give the new liner and the connection between the liner and  
30 the casing a uniform quality. At the end of this step, the cutter 100 and expander 400 are de-actuated and the piston surfaces thereon are retracted into the respective bodies. The run-in string is then raised to place the bearing 310 in contact with shoulder

member at the top of the liner 315. The apparatus 300 can then be removed from the wellbore along with the run-in string 305, leaving the liner installed in the wellbore casing.

5           As the foregoing demonstrates, the present invention provides an easy efficient way to separate tubulars in a wellbore without the use of a rigid run-in string. Alternatively, the invention provides a trip saving method of setting a string of tubulars in a wellbore. Also provided is a space saving means of setting a liner in a wellbore by expanding a first section of tubular into a larger section of tubular therearound.

10

As illustrated by the foregoing, it is possible to form a mechanical connection between two tubulars by expanding the smaller tubular into the inner surface of the larger tubular and relying upon friction therebetween to affix the tubulars together. In this manner, a smaller string of tubulars can be hung from a larger string of tubulars in a wellbore. In some instances, it is necessary that the smaller diameter tubular have a relatively thick wall thickness in the area of the connection in order to provide additional strength for the connection as needed to support the weight of a string of tubulars therebelow that may be over 1,000 ft. in length. In these instances, expansion of the tubular can be frustrated by the excessive thickness of the tubular wall. For instance, tests have shown that as the thickness of a tubular wall increases, the outer surface of the tubular can assume a tensile stress as the interior surface of the wall is placed under a compressive radial force necessary for expansion. When using the expansion tool of the present invention to place an outwardly directed radial force on the inner wall of a relating thick tubular, the expansion tool, with its actuated rollers, places the inner surface of the tubular in compression. While the inside surface of the wall is in compression, the compressive force in the wall will approach a value of zero and subsequently take on a tensile stress at the outside surface of the wall. Because of the tensile stress, the radial forces applied to the inner surface of the tubular may be inadequate of efficiently expand the outer wall past its elastic limits.

20  
25  
30

In order to facilitate the expansion of tubulars, especially those requiring a relatively thick wall in the area to be expanded, formations are created on the outer

surface of the tubular as shown in Figure 15. Figure 15 is a perspective view of a tubular 500 equipped with threads at a first end to permit installation on an upper end of a tubular string (not shown). The tubular includes substantially longitudinal formations 502 formed on an outer surface thereof. The formations 502 have the effect of increasing the wall thickness of the tubular 500 in the area of the tubular to be expanded into contact with an outer tubular. This selective increase in wall thickness reduces the tensile forces developed on the outer surface of the tubular wall and permits the smaller diameter tubular to be more easily expanded into the larger diameter tubular. In the example shown in Figure 15, the formations 502 and grooves 504 formed on the outer surface of the tubular 500 therebetween are not completely longitudinal but are spiraled in their placement along the tubular wall. The spiral shape of the grooves and formations facilitate the flow of fluids, like cement and also facilitate the expansion of the tubular wall as it is acted upon by an expansion tool. Additionally, formed on the outer surface of formations 502 are slip teeth 506 which are specifically designed to contact the inner surface of a tubular therearound, increasing frictional resistance to downward axial movement. In this manner, the tubular can be expanded in the area of the formations 502 and the formations, with their teeth 506 will act as slips to prevent axial downward movement of the tubing string prior to cementing of the tubular string in the wellbore. Formed on the outer surface of the tubular 500 above the formations 502 are three circumferential grooves 508 which are used with seal rings (not shown) to seal the connection created between the expanded inner tubular 500 and an outer tubular.

Figure 16 is a section view of the tubular 500 with that portion including the formations 502 expanded into contact with a larger diameter tubular 550 therearound. As illustrated in Figure 16, that portion of the tubular including the formations has been expanded outwards through use of an expansion tool (not shown) to place the teeth 506 formed on the formations 502 into frictional contact with the larger tubular 550 therearound. Specifically, an expansion tool operated by a source of pressurized fluid has been inserted into the tubular 500 and through selective operation, expanded a portion of tubular 500. The spiral shape of the formations 502 has resulted in a smoother expanded surface of the inner tubular as the rollers of the expansion tool have

5 moved across the inside of the tubular at an angle causing the rollers to intersect the angle of the formations opposite the inside wall of the tubular 500. In the condition illustrated in Figure 16, the weight of the smaller diameter tubular 500 (and any tubular string attached thereto) is borne by the larger diameter tubular 550. However, the grooves 504 defined between the formations 502 permit fluid, like cement to circulate through the expanded area between the tubulars 500, 550.

10 Figure 17 is a section view of the tubular 500 of Figure 16 wherein the upper portion of the tubular 500 has also been expanded into the inner surface of the larger diameter tubular 550 to effect a seal therebetween. As illustrated, the smaller tubular is now mechanically and sealingly attached to the outer tubular through expansion of the formations 502 and the upper portion of the smaller tubular 550 with its circumferential grooves 508. Visible in Figure 16, the grooves 508 include rings 522 made of some elastomeric material that serves to seal the annular area between the tubulars 500, 550 when expanded into contact with each other. Typically, this step is performed after cement has been circulated around the connection point but prior to the cement having cured.

20 In use, the connection would be created as follows: A tubular string 500 with the features illustrated in Figure 15 is lowered into a wellbore to a position whereby the formations 502 are adjacent the inner portion of an outer tubular 550 where a physical connection between the tubulars is to be made. Thereafter, using an expansion tool of the type disclosed herein, that portion of the tubular bearing the formations is expanded outwardly into the outer tubular 550 whereby the formations 502 and any teeth formed thereupon are placed in frictional contact with the tubular 550 therearound. Thereafter, with the smaller diameter tubular fixed in place with respect to the larger diameter outer tubular 550, any fluids, including cement are circulated through an annular area created between the tubulars 500, 550 or tubular 500 and a borehole therearound. The grooves 504 defined between the formations 502 of the tubular 500 permit fluid to pass therethrough even after the formations have been urged into contact with the outer tubular 550 through expansion. After any cement has been circulated through the connection, and prior to any cement curing, the connection between the inner and outer

25

30

tubulars can be sealed. Using the expansion tool described herein, that portion of the tubular having the circumferential grooves 508 therearound with rings 522 of elastomeric material therein is expanded into contact with the outer tubular 550. A redundant sealing means over the three grooves 508 is thereby provided.

5

In another aspect, the invention provides a method and apparatus for expanding a first tubular into a second and thereafter, circulating fluid between the tubulars through a fluid path independent of the expanded area of the smaller tubular. Figure 18 is a section view of a first, smaller diameter tubular 600 coaxially disposed in an outer, larger diameter tubular 650. As illustrated, the upper portion of the smaller diameter tubular includes a circumferential area 602 having teeth 606 formed on an outer surface thereof which facilitate the use of the circumferential area 602 as a hanger portion to fixedly attach the smaller diameter tubular 600 within the larger diameter tubular 650. In the illustration shown, the geometry of the teeth 606 formed on the outer surface of formations 602 increase the frictional resistance of a connection between the tubulars 600, 650 to a downward force. Below the circumferential area 602 are two apertures 610 formed in a wall of the smaller diameter tubular 600. The purpose of apertures 610 is to permit fluid to pass from the outside of the smaller diameter tubular 600 to the inside thereof as will be explained herein. Below the apertures 610 are three circumferential grooves 620 formed in the wall of the smaller diameter tubular 600. These grooves 620 aid in forming a fluid tight seal between the smaller diameter and larger diameter tubulars 600, 650. The grooves 620 would typically house rings 622 of elastomeric material to facilitate a sealing relationship with a surface therearound. Alternatively, the rings could be any malleable material to effect a seal. Also illustrated in Figure 18 is a cone portion 629 installed at the lower end of a tubular string 601 extending from the tubular 600. The cone portion 629 facilitates insertion of the tubular 601 into the wellbore.

Figure 19 is a section view of the smaller 600 and larger 650 diameter tubulars of Figure 18 after the smaller diameter tubular 600 has been expanded in the circumferential area 602. As illustrated in Figure 19, area 602 with teeth 606 has been placed into frictional contact with the inner surface of the larger tubular 650. At this

30

point, the smaller diameter tubular 600 and any string of tubular 601 attached therebelow is supported by the outer tubular 650. However, there remains a clear path for fluid to circulate in an annular area formed between the two tubulars as illustrated by arrows 630. The arrows 630 illustrate a fluid path from the bottom of the tubular string  
5 601 upwards in an annulus formed between the two tubulars and through apertures 610 formed in smaller diameter tubular 600. In practice, cement would be delivered into the tubular 610 to some point below the apertures 610 via a conduit (not shown). A sealing mechanism around the conduit (not shown) would urge fluid returning through apertures 610 towards the upper portion of the wellbore.

10

Figure 20 is a section view of the smaller 600 and larger 650 diameter tubulars. As illustrated in Figure 20, that portion of the smaller diameter tubular 600 including sealing grooves 620 with their rings 622 of elastomeric material have been expanded into the larger diameter tubular 650. The result is a smaller diameter tubular 600 which  
15 is joined by expansion to a larger diameter tubular 650 therearound with a sealed connection therebetween. While the tubulars 600, 650 are sealed by utilizing grooves and elastomeric rings in the embodiment shown, any material could be used between the tubulars to facilitate sealing. In fact, the two tubulars could simply be expanded together to effect a fluid-tight seal.

20

In operation, a tubular string having the features shown in Figure 18 at an upper end thereof would be used as follows: The tubular string 601 would be lowered into a wellbore until the circumferential area 602 of an upper portion 600 thereof is adjacent that area where the smaller diameter tubular 600 is to be expanded into a larger diameter  
25 tubular 650 therearound. Thereafter, using an expansion tool as described herein, that portion of the smaller diameter tubular 600 including area 602 is expanded into frictional contact with the tubular 650 therearound. With the weight of the tubular string 601 supported by the outer tubular 650, any fluid can be circulated through an annular area defined between the tubulars 600, 650 or between the outside of the  
30 smaller tubular and a borehole therearound. As fluid passes through the annular area, circulation is possible due to the apertures 610 in the wall of the smaller diameter tubular 600. Once the circulation of cement is complete, but before the cement cures,

that portion of the smaller diameter tubular 600 bearing the circumferential grooves 620 with elastomeric seal rings 622 is expanded. In this manner, a hanging means is created between a first smaller diameter tubular 600 and a second larger diameter tubular 650 whereby cement or any other fluid is easily circulated through the connection area after  
5 the smaller diameter tubular is supported by the outer larger diameter tubular but before a seal is made therebetween. Thereafter, the connection between the two tubulars is sealed and completed.

While foregoing is directed to the preferred embodiment of the present  
10 invention, other and further embodiments of the invention may be devised without departing from the basic scope thereof, and the scope thereof is determined by the claims that follow.

The embodiments of the invention in which an exclusive property or privilege is claimed are defined as follows:

1. A method of cutting a tubular in a wellbore comprising:  
expanding at least a portion of the tubular in the wellbore;  
conveying a cutting member into the wellbore;  
separating the tubular into a first section and a second section;  
removing the first section from the wellbore.
2. The method of claim 1, wherein the tubular is separated proximate an expanded portion of the tubular.
3. The method of claim 1 or 2, wherein the second section is at least partially expanded.
4. The method of claim 1, 2 or 3, further comprising forming a connection between the second section and a larger diameter tubular.
5. The method of any one of claims 1 to 4, wherein the tubular is separated at an unexpanded portion of the tubular.
6. The method of any one of claims 1 to 5, further comprising actuating the cutting member.

7. The method of claim 6, wherein actuating the cutting member comprises extending the cutting member radially into engagement with the tubular.
8. The method of claim 7, further comprising rotating the cutting member to separate the tubular.
9. The method of claim 6, 7 or 8, further comprising supplying fluid pressure to actuate the cutting member.
10. The method of any one of claims 1 to 9, wherein the cutting member comprises a plurality of cutting blades.
11. The method of claim 10, further comprising placing the plurality of cutting blades in an unactuated position.
12. The method of any one of claims 1 to 11, wherein the tubular is conveyed into the wellbore along with the cutting member.
13. The method of any one of claims 1 to 11, wherein an expander tool is conveyed into the wellbore along with the cutting member.
14. The method of claim 13, wherein the tubular is conveyed into the wellbore along with the cutting member.

15. The method of any one of claims 1 to 14, further comprising expanding at least a portion of the second section of the tubular.
16. The method of any one of claims 1 to 15, wherein separating the tubular comprises rotating the cutting member.
17. The method of any one of claims 1 to 16, wherein the tubular comprises a casing.
18. A tool string for cutting and expanding a tubular in a wellbore, comprising:  
a cutting tool disposed on the tool string, the cutting tool configured for transversely severing the tubular; and  
an expansion tool disposed on the tool string.
19. The tool string of claim 18, wherein the cutting tool is rotatable and includes a radially extendable cutter for contacting an inside of the tubular in order to sever the tubular.
20. The tool string of claim 18 or 19, wherein the expansion tool is rotatable and includes a radially extendable member for contacting an inside of the tubular and applying a radial force to expand the tubular.
21. A method of expanding and cutting a tubular in a wellbore, comprising:  
running an apparatus into the wellbore, the apparatus including a cutter and an expander disposed on a run-in string;  
operating the expander to expand a portion of the tubular; and

operating the cutter to sever transversely the tubular.

22. A method of cutting a tubular in a wellbore, comprising:
- disposing at least a portion of the tubular in a larger diameter tubular;
  - providing a cutting apparatus having an extendable cutting member;
  - extending the cutting member into contact with the tubular; and
  - rotating the cutting apparatus to deform the tubular, the degree of deformation being such that the tubular is cut; and
  - expanding the tubular.
23. The method of claim 22, wherein the cutting member is freely rotatable about an axis which is substantially parallel to the longitudinal axis of the cutting apparatus.
24. The method of claim 22 or 23, wherein the cutting member comprises a roller having a raised circumferential portion formed thereon.
25. The method of claim 22, 23 or 24, wherein the cutting apparatus further comprises an actuator for extending or retracting the cutting member.
26. The method of claim 25, wherein extending the cutting member comprises supplying fluid pressure to activate the actuator.
27. The method of claim 21 or 22, wherein the actuator comprises a piston.

28. The method of any one of claims 22 to 27, wherein the tubular is cut at an unexpanded portion of the tubular.
29. The method of any one of claims 22 to 27, wherein the tubular is cut proximate an expanded portion.
30. The method of any one of claims 22 to 27, wherein the tubular is cut at the portion of the tubular disposed in the larger diameter tubular.
31. The method of any one of claims 22 to 30, wherein expanding the tubular and cutting the tubular is performed in a single trip into the wellbore.
32. The method of any one of claims 22 to 31, wherein the tubular is expanded into contact with the larger diameter tubular.
33. A method of cutting a section of tubing in a borehole, comprising:  
providing a cutting device having at least one radially movable piston that includes a cutter;  
positioning the device in the borehole adjacent a tubular in the borehole;  
supplying fluid pressure through a conduit to an internal portion of the cutting device, thereby extending the piston such that at least a portion of the cutter contacts the tubular;  
and  
rotating the cutting device to deform the tubular, the degree of deformation being such that the tubular is cut.

1/15

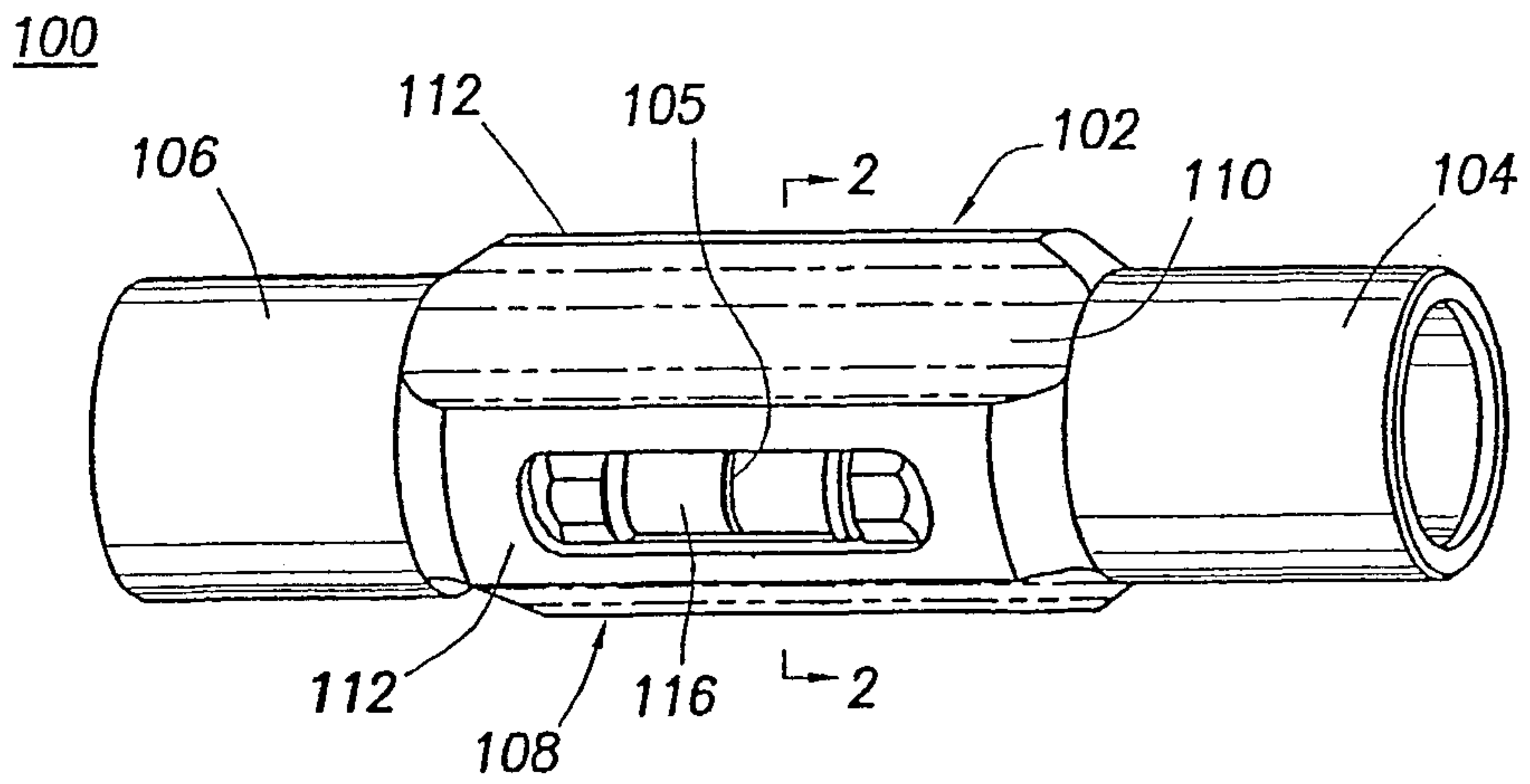

FIG. 1

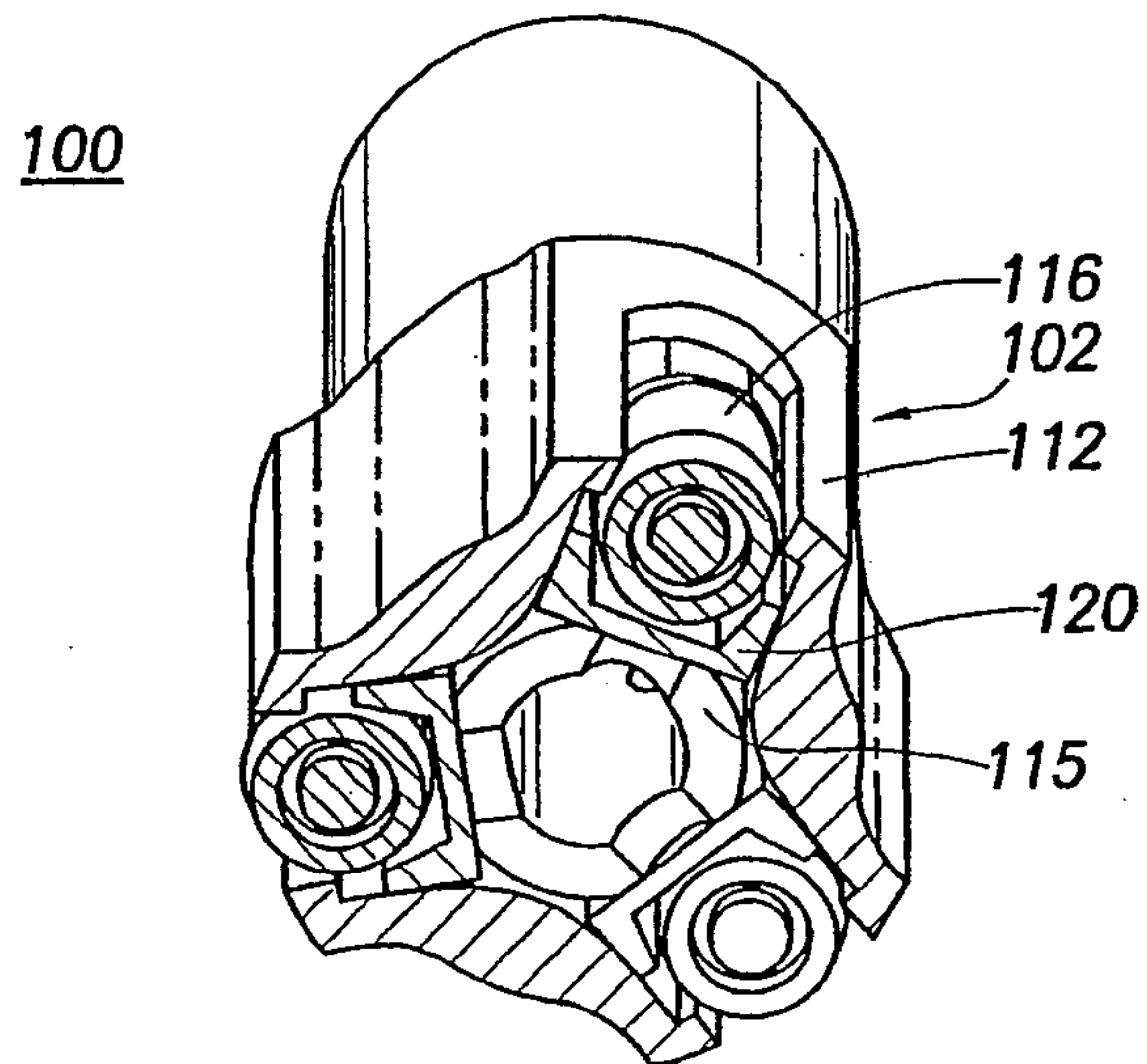

FIG. 2

2/15

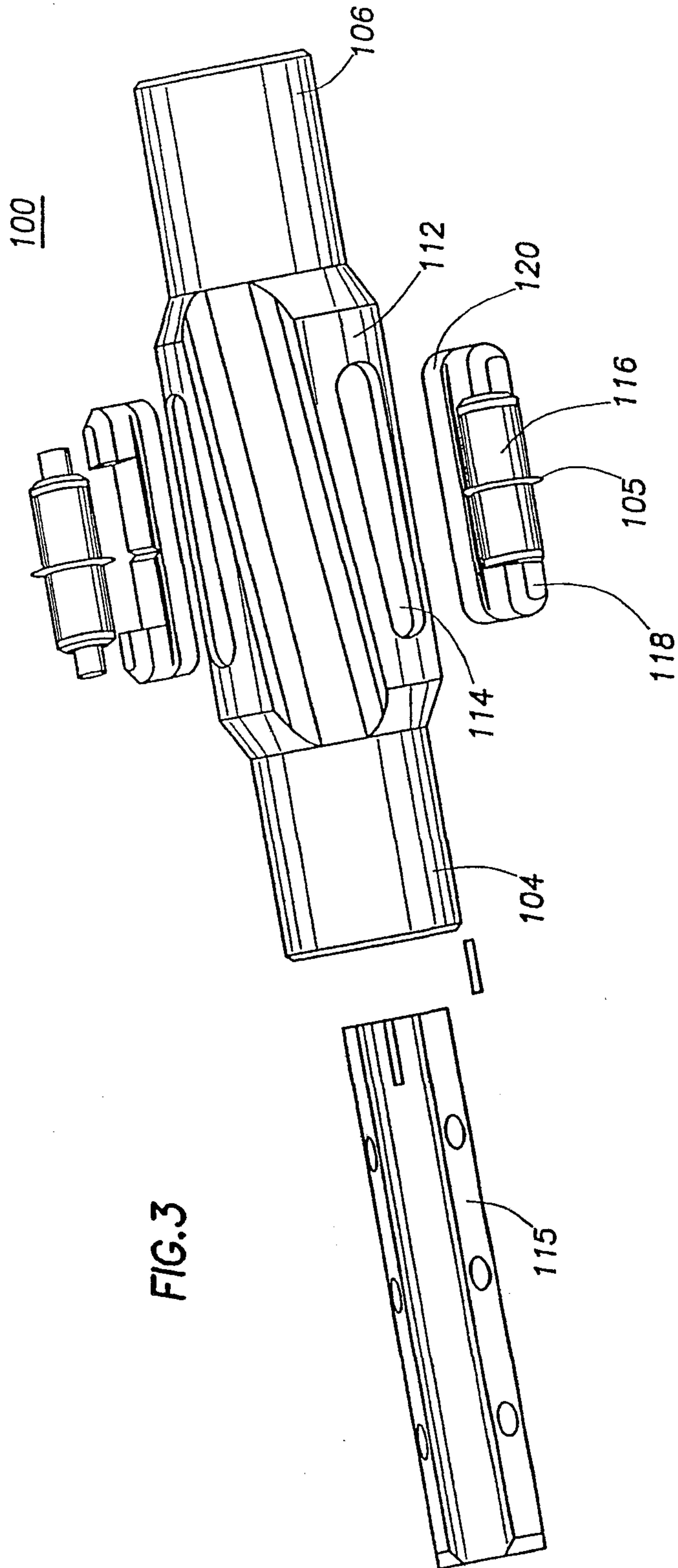

FIG.3

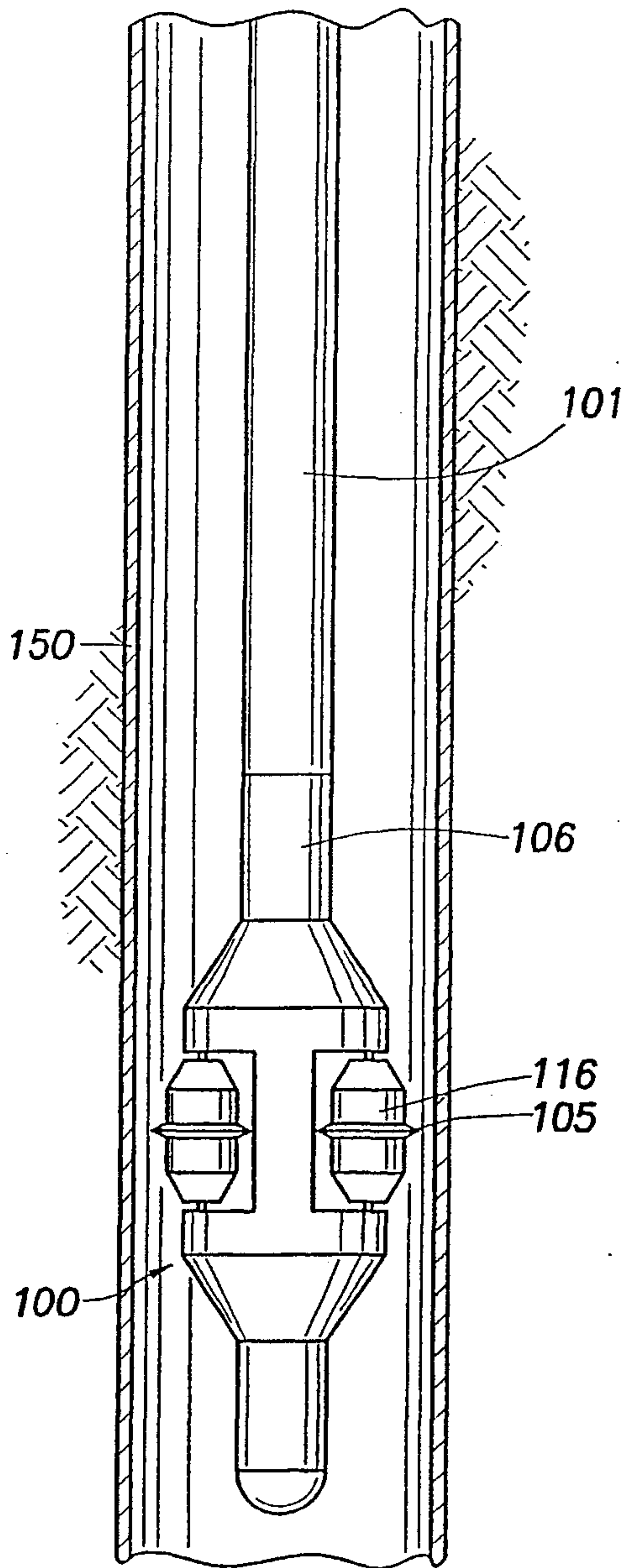

FIG. 4

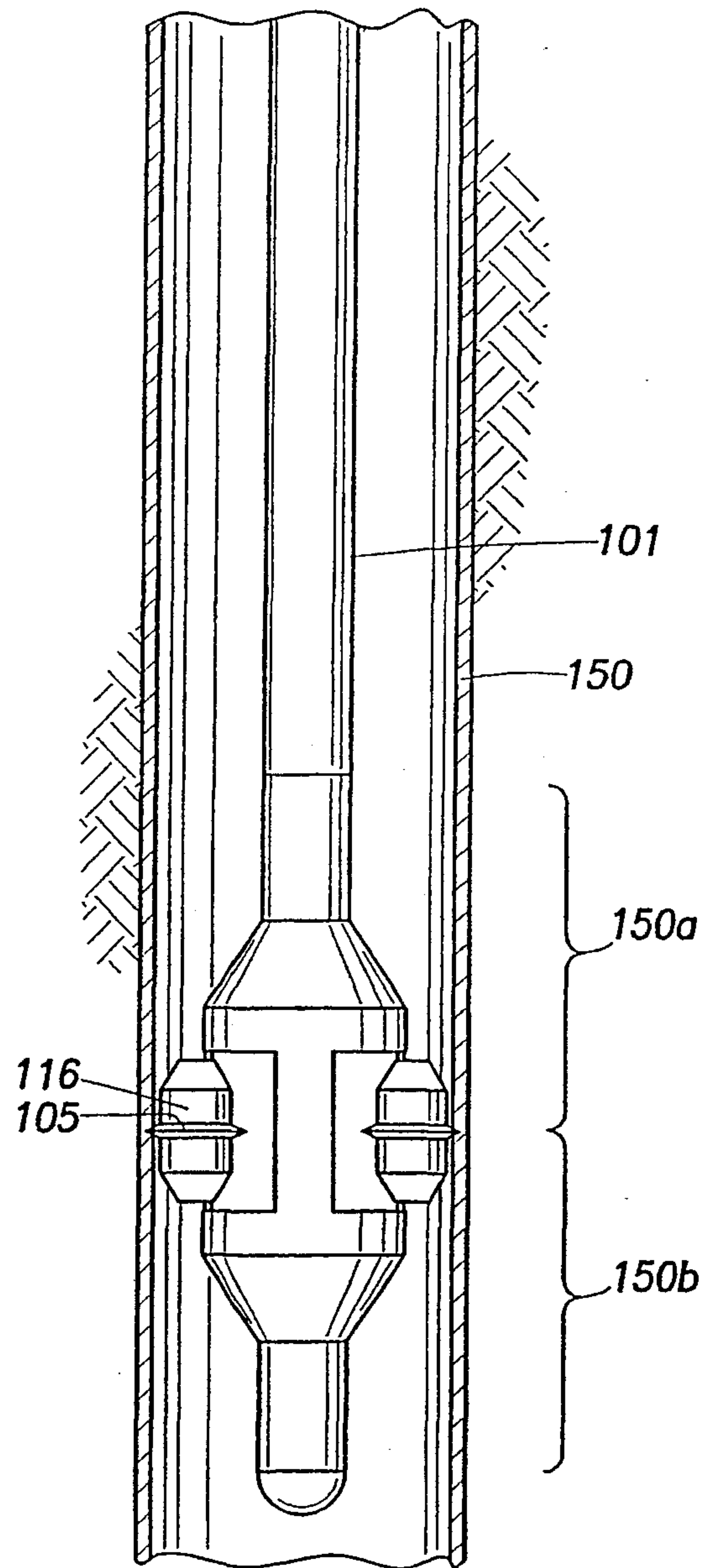

FIG. 5

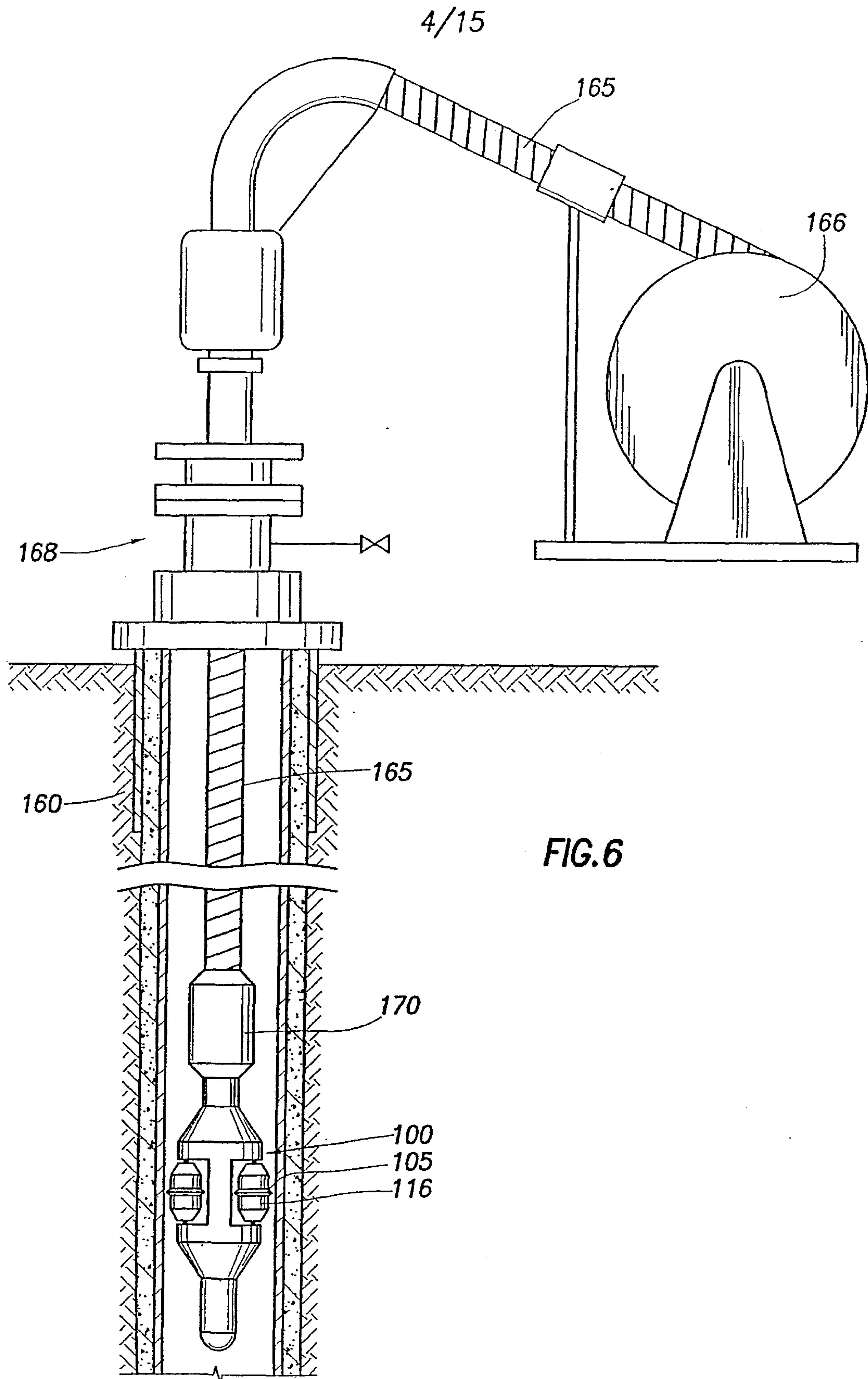

FIG. 6

+

5/15

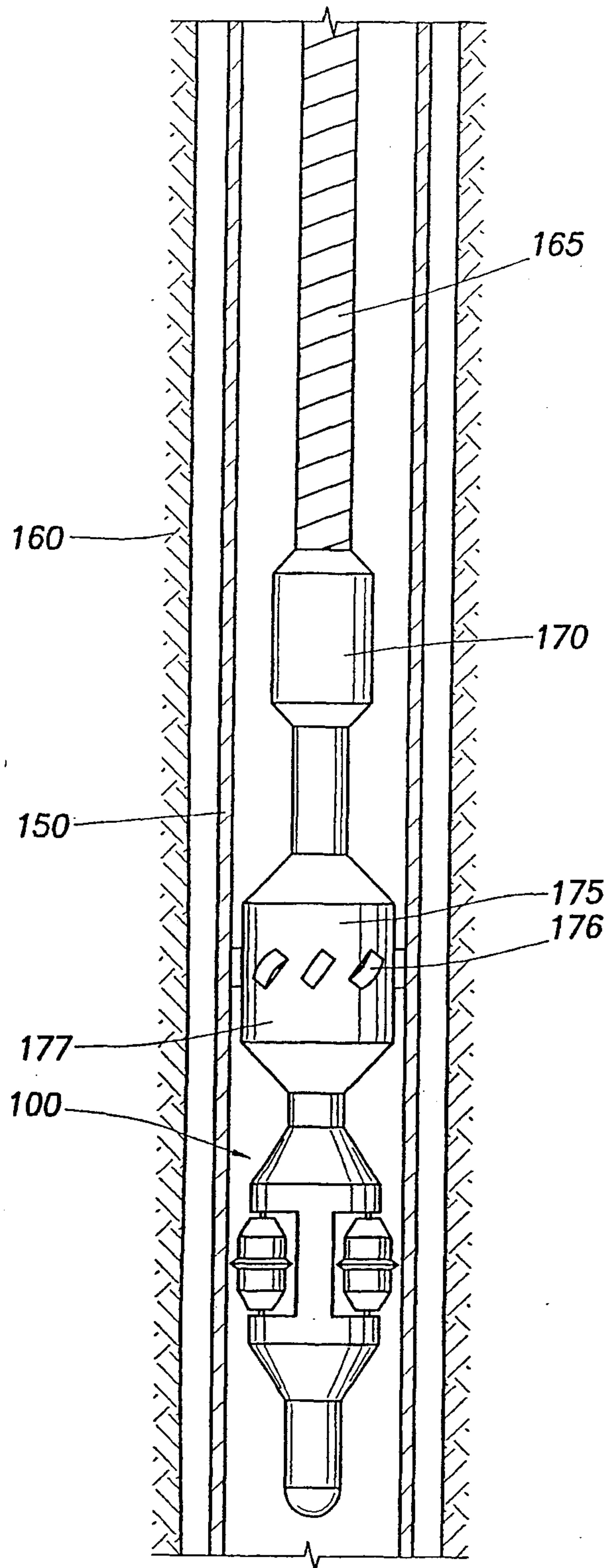

FIG.7

+

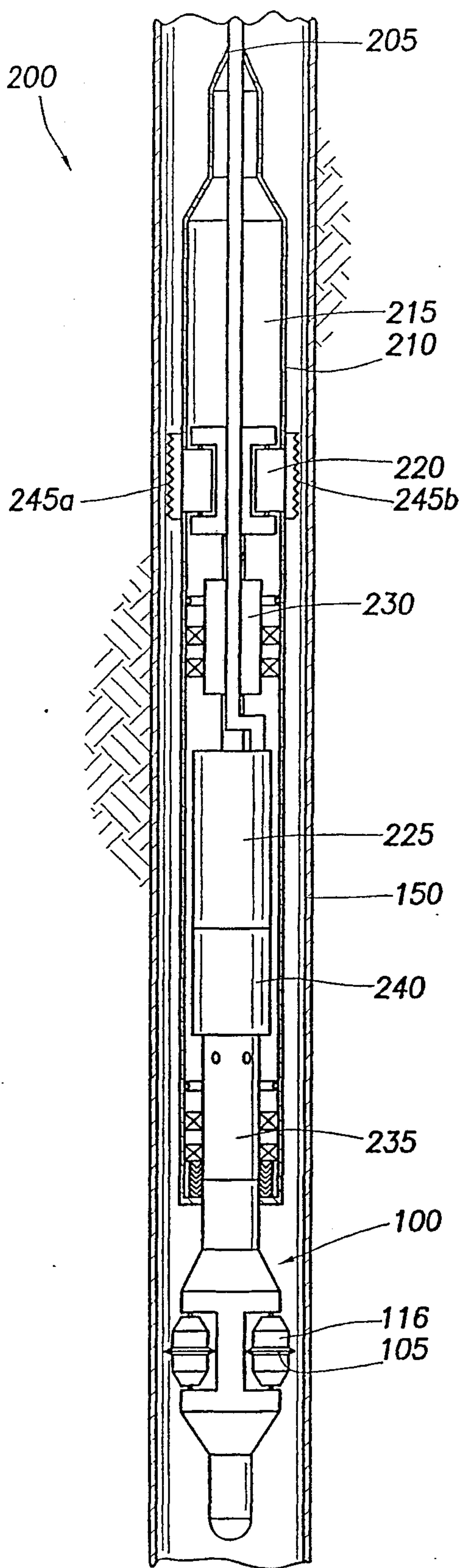

FIG. 8

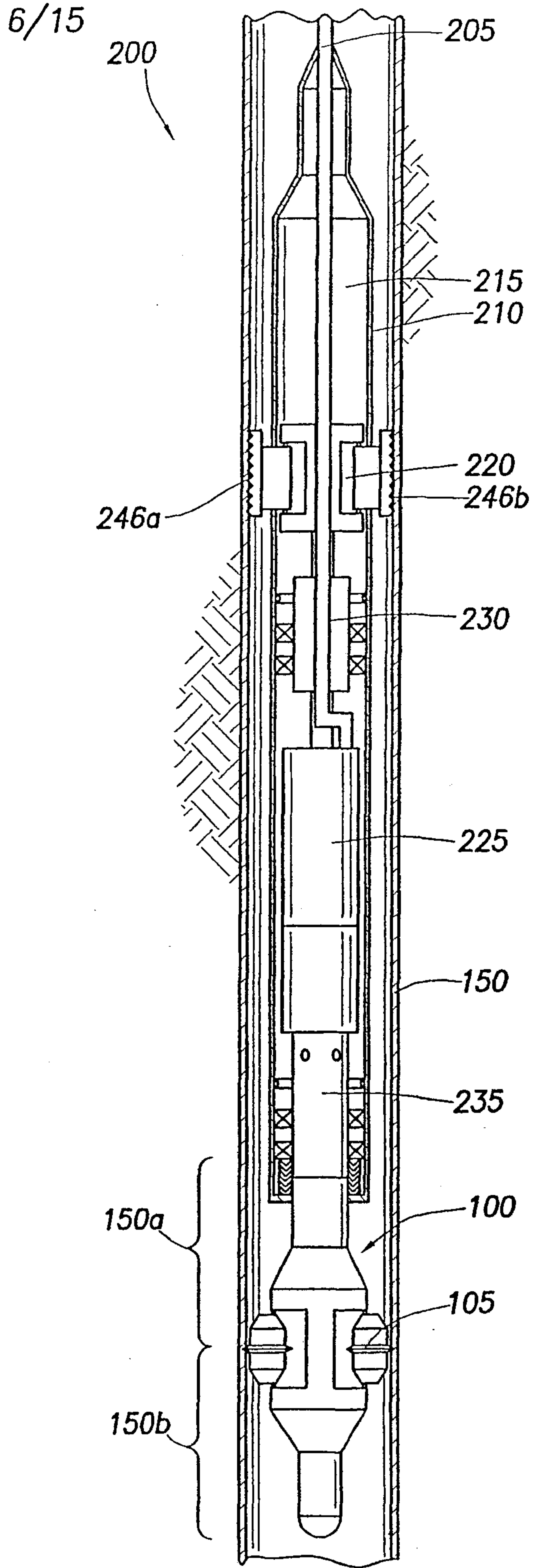

FIG. 9

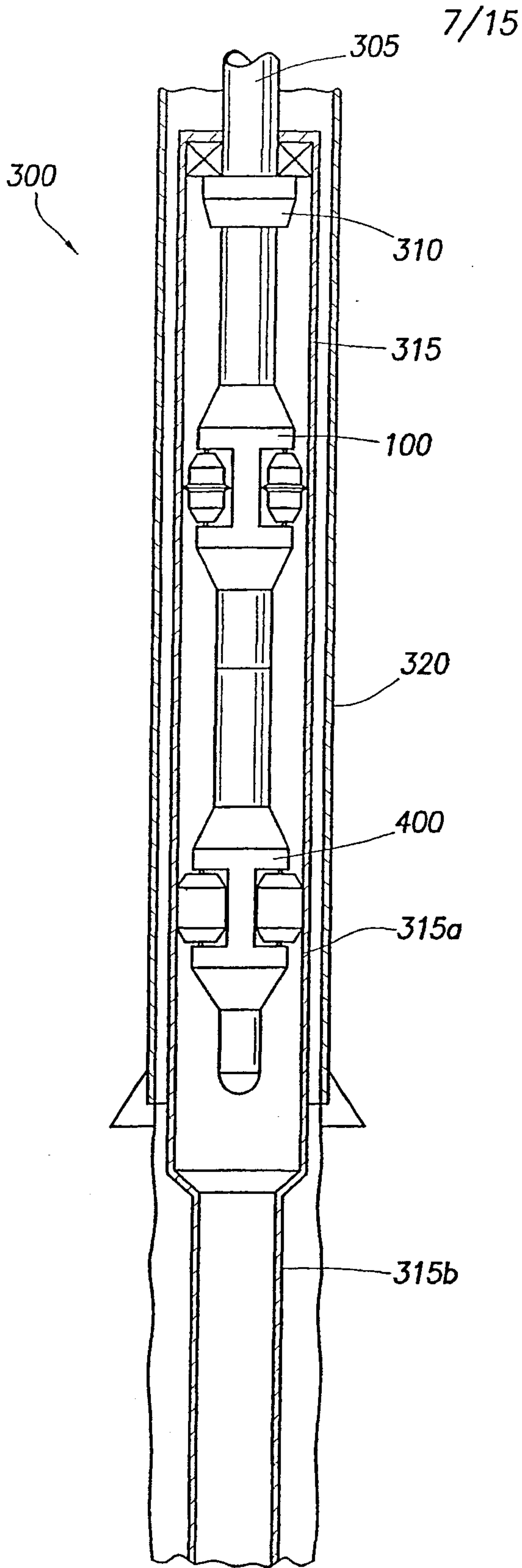

FIG. 10

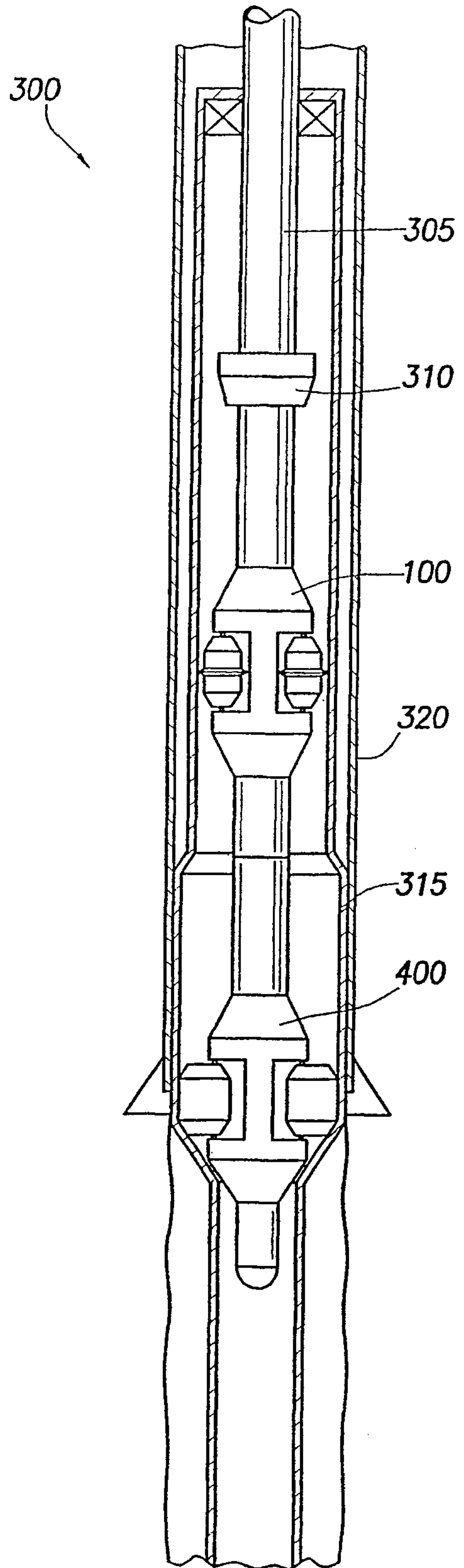
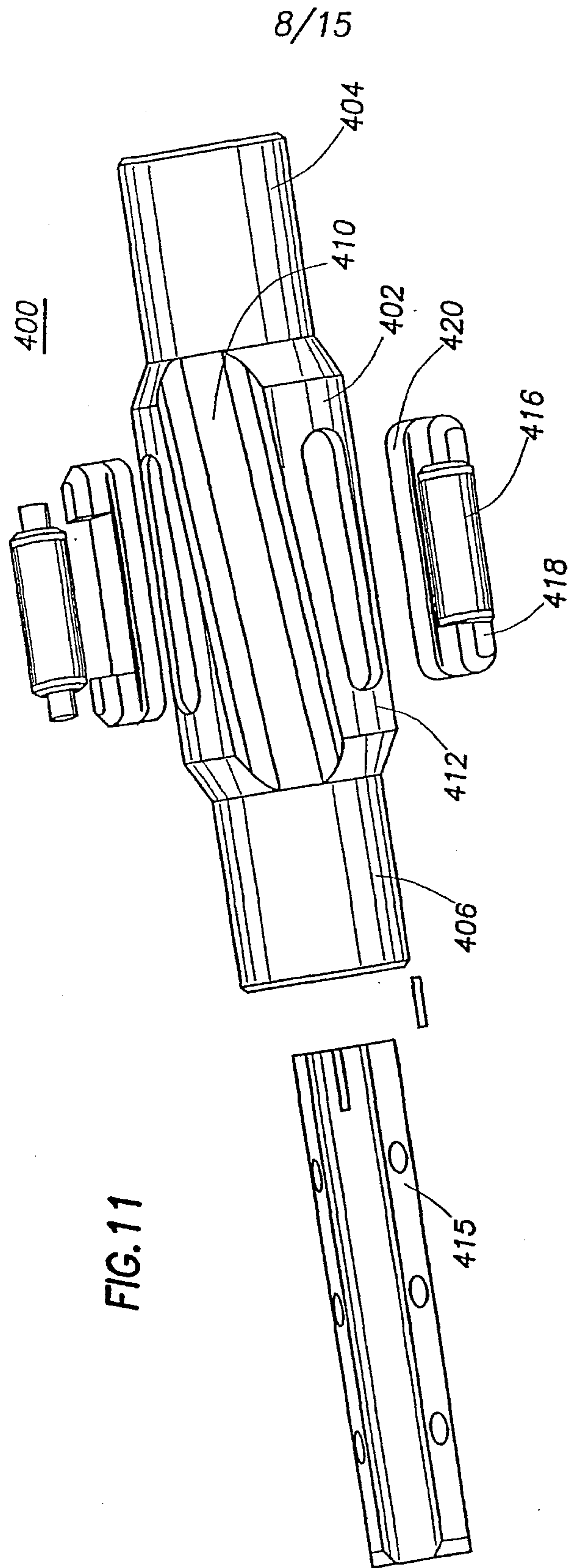

FIG. 12



9/15

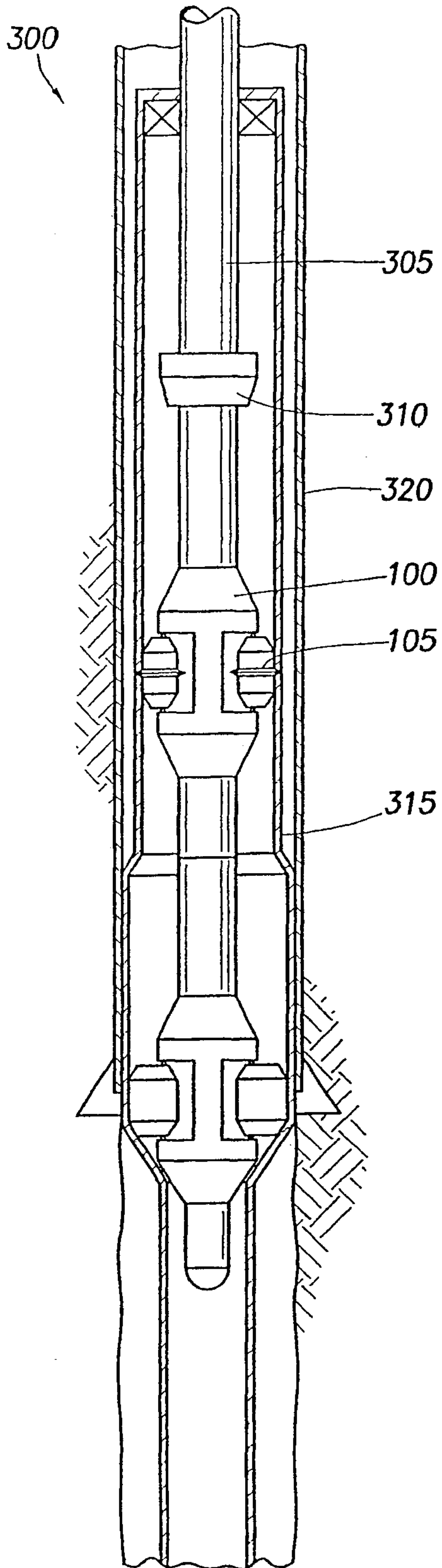

FIG. 13

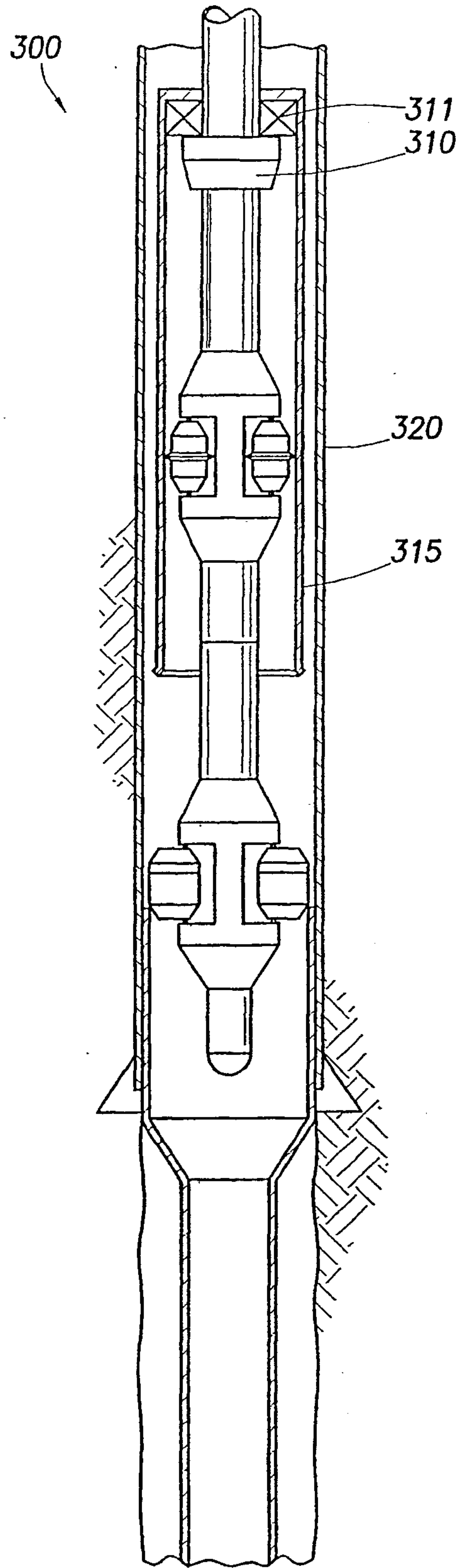

FIG. 14

10/15

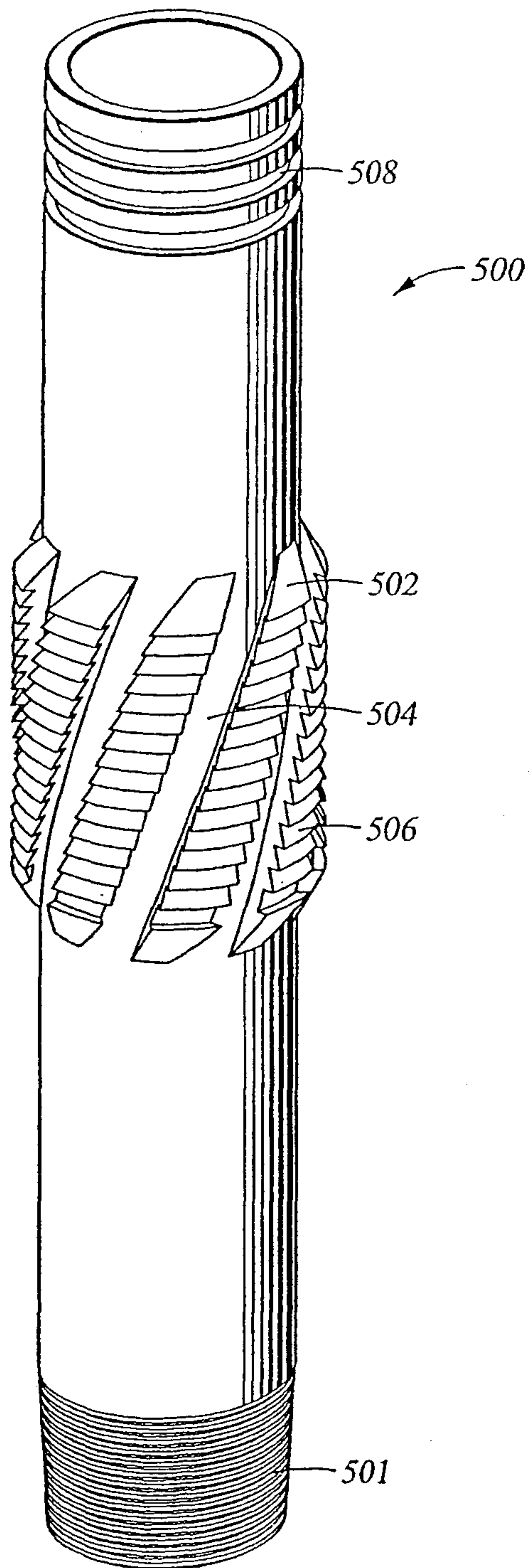

Fig. 15

11/15

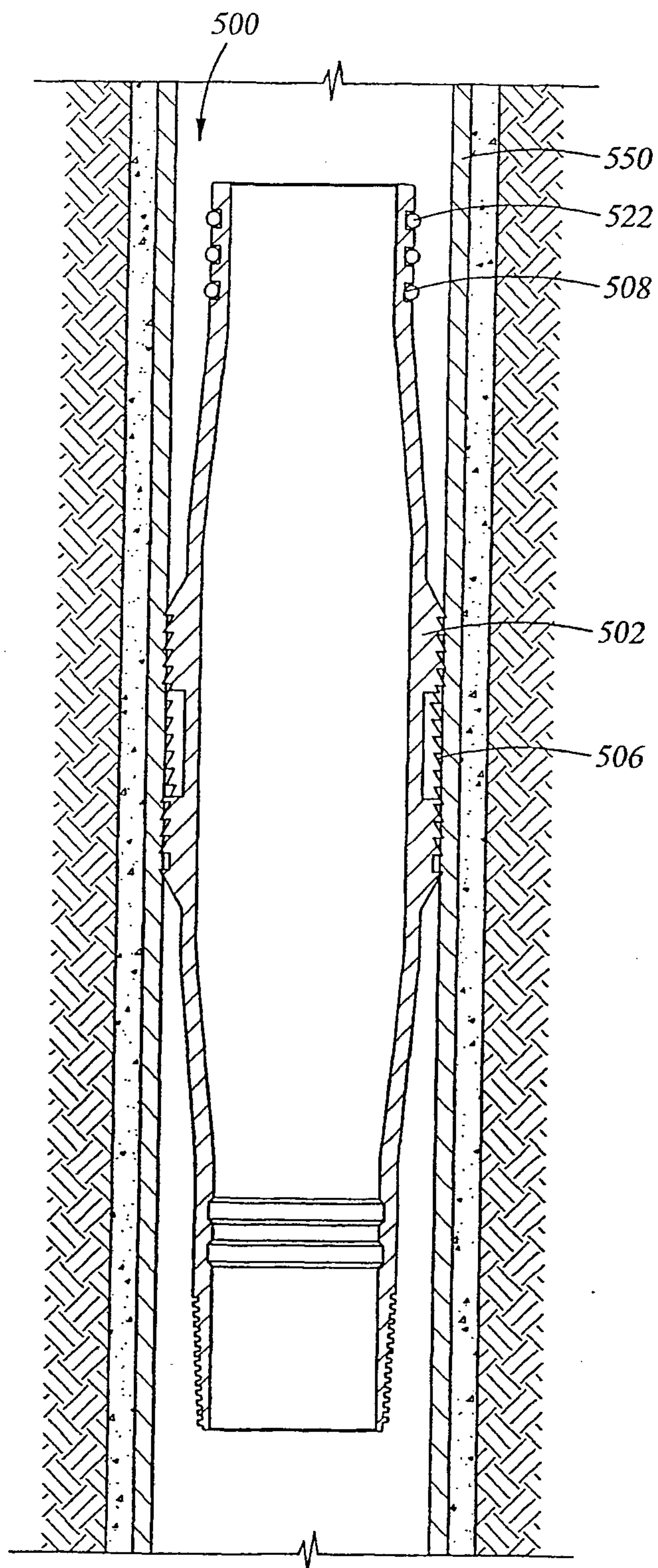

Fig. 16

12/15

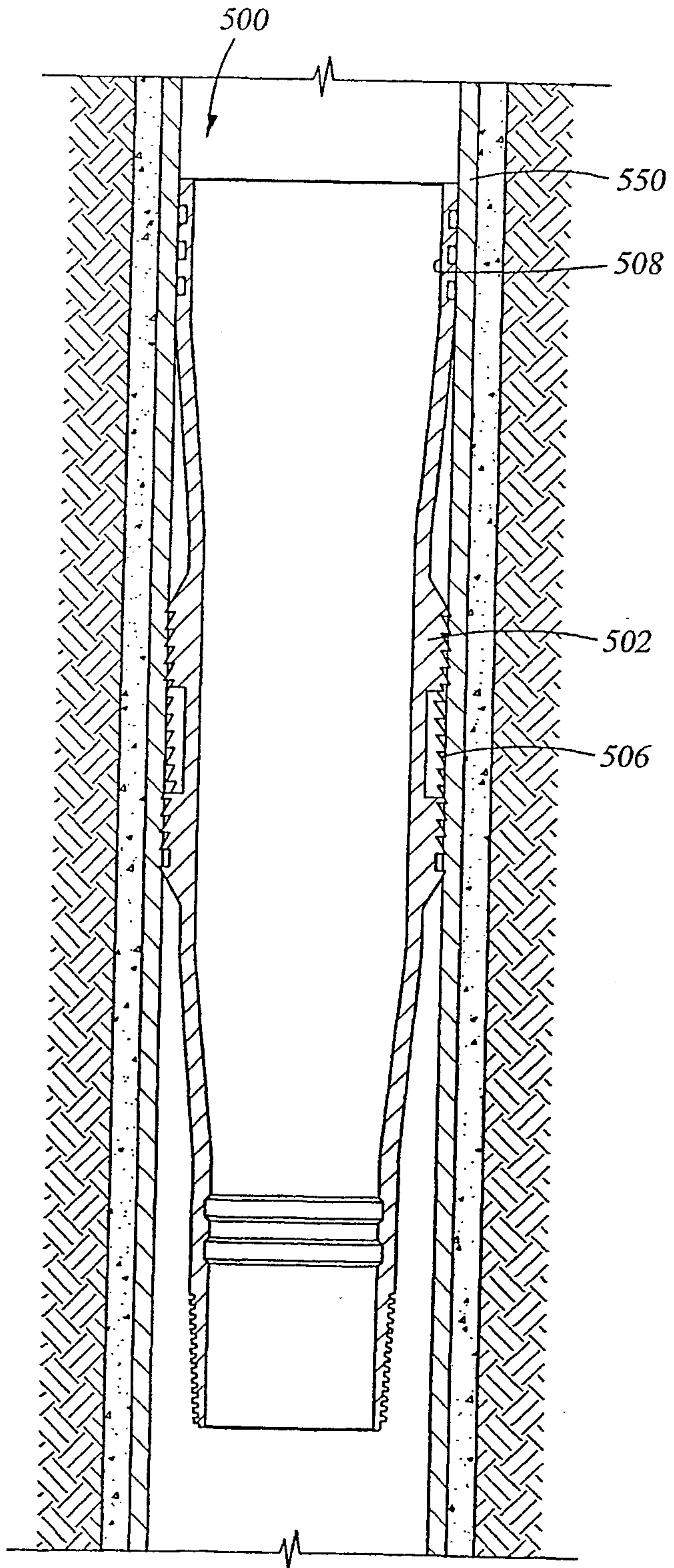
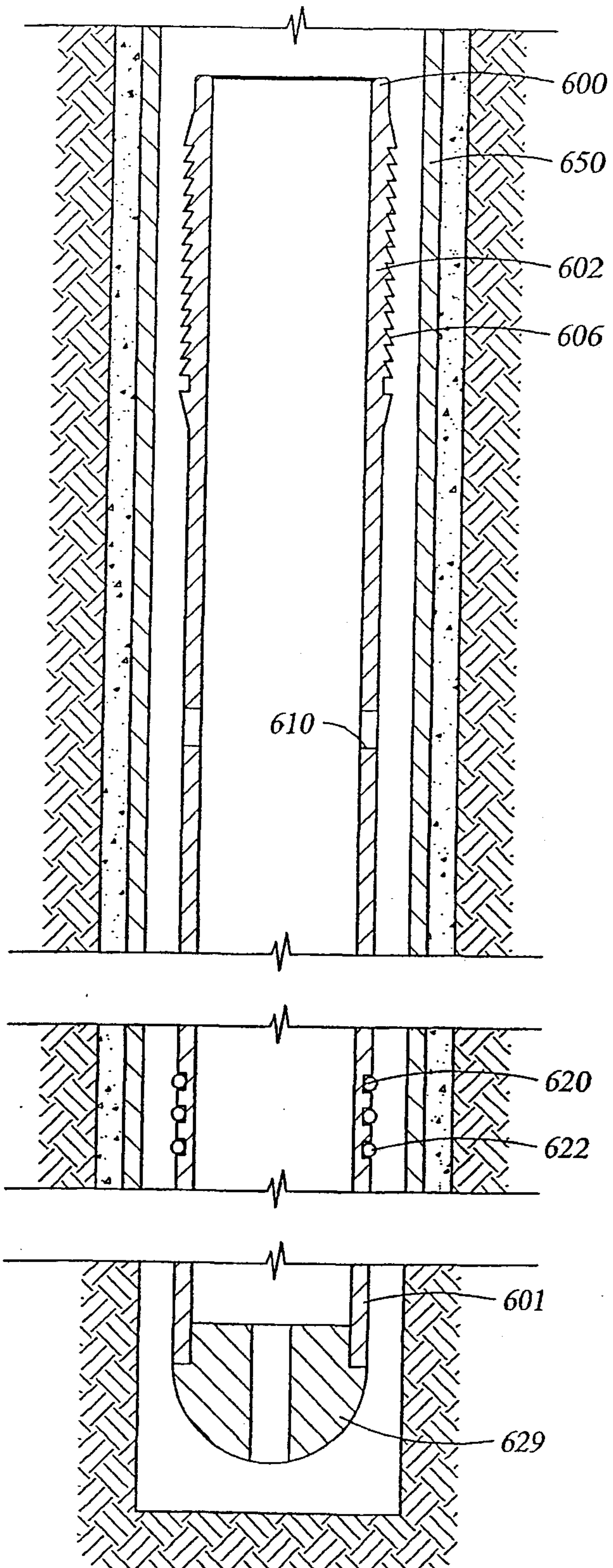

Fig. 17

13/15

Fig. 18



14/15

Fig. 19

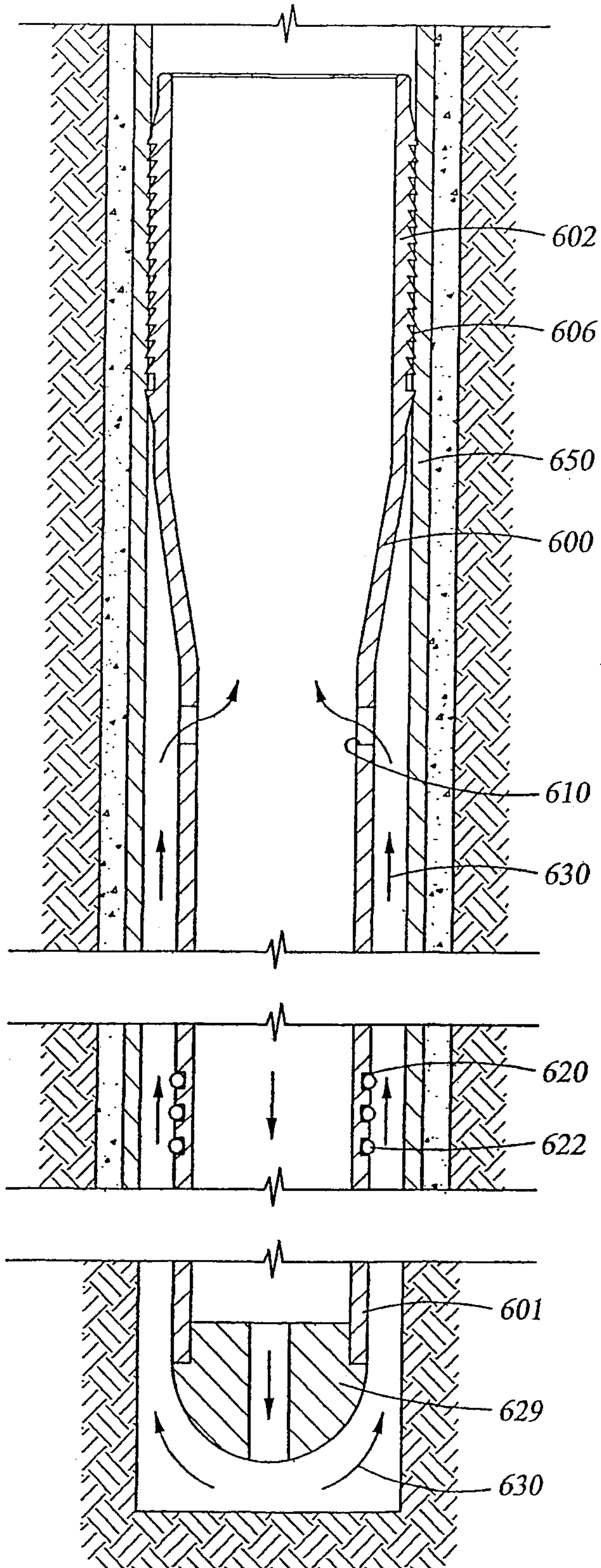

15/15

Fig. 20

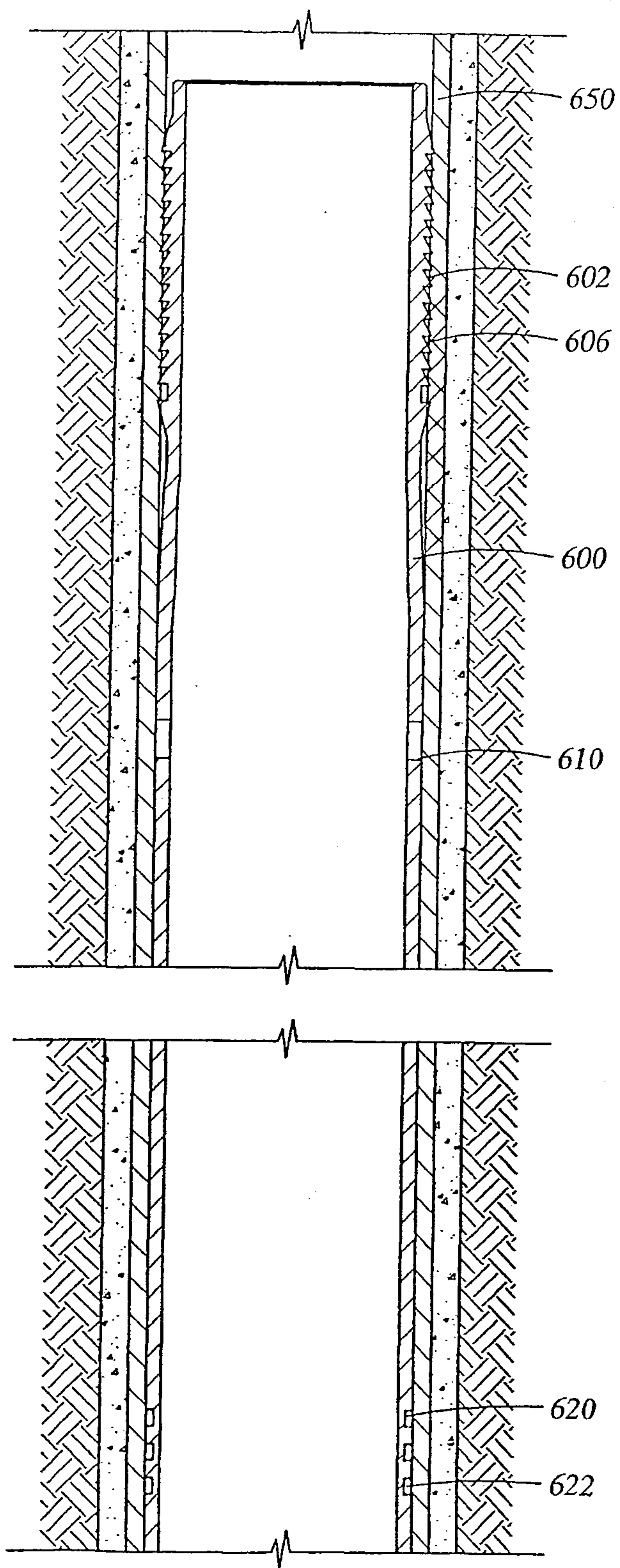

100

