



(11) **EP 2 854 150 B1**

(12) **EUROPEAN PATENT SPECIFICATION**

(45) Date of publication and mention of the grant of the patent:
14.06.2017 Bulletin 2017/24

(51) Int Cl.:
H01H 50/02 ^(2006.01) **H01H 50/44** ^(2006.01)
H01H 50/54 ^(2006.01)

(21) Application number: **14186542.8**

(22) Date of filing: **26.09.2014**

(54) **Electromechanical relay**

Elektromechanisches Relais

Relais électromécanique

(84) Designated Contracting States:
AL AT BE BG CH CY CZ DE DK EE ES FI FR GB GR HR HU IE IS IT LI LT LU LV MC MK MT NL NO PL PT RO RS SE SI SK SM TR

(30) Priority: **26.09.2013 BE 201300642**

(43) Date of publication of application:
01.04.2015 Bulletin 2015/14

(73) Proprietor: **Niko NV**
9100 Sint-Niklaas (BE)

(72) Inventors:
• **Devenyn, Diederik Jozef Luc**
9820 Merelbeke (BE)

• **Tiels, Koen Reinout Roeland**
9100 Sint-Niklaas (BE)

(74) Representative: **D'Halleweyn, Nele Veerle Trees Gertrudis et al**
Arnold & Siedsma
Bezuidenhoutseweg 57
2594 AC The Hague (NL)

(56) References cited:
DE-A1- 19 823 987 **JP-A- H1 050 186**
JP-A- 2007 087 828 **US-A1- 2002 186 109**
US-A1- 2003 174 038 **US-A1- 2009 096 560**
US-B1- 6 229 417

EP 2 854 150 B1

Note: Within nine months of the publication of the mention of the grant of the European patent in the European Patent Bulletin, any person may give notice to the European Patent Office of opposition to that patent, in accordance with the Implementing Regulations. Notice of opposition shall not be deemed to have been filed until the opposition fee has been paid. (Art. 99(1) European Patent Convention).

Description

[0001] The present invention relates to an electromechanical relay according to the preamble of claim 1. More particularly, the present invention relates to an electromechanical relay that fits into electrical devices with limited space or special shapes.

[0002] US 2003/174038 discloses a relay 7 comprising a first non-flexible substrate 16 and a second flexible substrate 40, see figure 1 below. There is provided a conductive member 17 on top of the first substrate 16 and the conductive member 50 on top of the second flexible substrate 40. Further, there is provided a coil 22 in coil support structure 11 attached to the second substrate 16. Opposite the coil 22, on top of the flexible substrate 40, there is provided a ferritic member 48. The description explains that although only two coils are shown, the array may have a 10x10 array or larger to provide a multitude of independent or dependent relay circuits as desired.

[0003] A known electromechanical relay typically comprises a coil that is mounted on a base made of, for example, iron (yoke), an armature of magnetic material which is movable with respect to the base, and a first contact element made out of electrically conductive material and connected to the armature. The first contact element is intended to establish or disconnect electrical contact with a second contact element, depending on whether the coil has been charged or not. By sending a current through the coil, a magnetic field is generated for moving the armature in such a way that the electrical contact between the first contact element and the second contact element is established or disconnected. Such a relay has as a disadvantage that it is not very compact, and, therefore, difficult to integrate into small electrical devices of which the space within the device is limited and/or of which the shape is fixed.

[0004] The aim of the present invention is to provide an electromechanical relay, the shape of which can be adapted to any desired shape of electrical device. In particular a relay is provided that, together with other electronic components, can fit into any kind of electrical device shape with a limited volume, and, more in particular, a compact relay that can form a relatively thin, flat unit.

[0005] For this purpose, an electromechanical relay according to the invention has the features of claim 1. The electromechanical relay comprises a carrier, a contact body which is connected to the carrier and which is movably mounted with respect to the carrier, at least one electrical contact element, and at least two coils to move the contact body with respect to the carrier, in order to disconnect or establish an electrical contact between the contact body and the at least one electrical contact element. The contact body is adapted to be moved as a result of a magnetic field generated by the at least two coils. The at least two coils are provided on or in the carrier and/or on or in the contact body. The carrier and/or the contact body are made out of electrically insulating material, on or in which electrically conductive tracks are

provided. The carrier and/or the contact body are further adapted for mounting electronic components thereon, which electronic components are connectable to the electrically conductive tracks.

5 **[0006]** Embodiments of the invention are *inter alia* based on the inventive insight to combine a plurality of coils with a relatively small height next to each other between a carrier and a contact body, and to give an additional function to the carrier and/or contact body, namely forming a mounting surface for electronic components, like resistors, capacitors, chips, etc. In this way, a relay can be obtained with any desired shape, and, in particular, a relatively thin and compact relay can be provided that is easy to integrate in an electronic circuit.

10 **[0007]** According to embodiments of the invention, the contact body is connected to the carrier and is, therefore, not floating.

15 **[0008]** A plurality of coils is located next to each other in a plane parallel to the carrier and/or the contact body. The axes of the coils may preferably be substantially perpendicular to the carrier and/or the contact body. The coils can be mounted onto the carrier and/or onto the contact body, whereby, for example, also at least a first coil can be mounted onto the carrier and at least a second coil onto the contact body.

20 **[0009]** The carrier and/or the contact body may preferably be implemented as a printed circuit board (PCB). The contact body and/or the carrier are preferably plate-shaped and may preferably be thin plates so that a thin assembly can be obtained. These plates can have any shape depending on the design of the electronic device in which the relay is required. Furthermore, the shape of the carrier can be different from or equal to the shape of the contact body. The carrier may preferably have a thickness of less than 3 mm. The contact body may preferably have a thickness of less than 3 mm.

25 **[0010]** According to a possible embodiment, the contact body may entirely be made out of a magnetic material, for example an iron alloy. According to another embodiment, the contact body may have zones of magnetic material, which are provided in such a way that they can cooperate with the coils, to guide the magnetic flux. According to still further embodiments, for example, one or more permanent magnets may be provided onto or in the contact body.

30 **[0011]** According to an advantageous embodiment, at least one spring means may be provided between the carrier and the contact body. The or each spring means may preferably have a first end that is fixed to the carrier and a second end that is fixed to the contact body. Using more than one coil and a spring-mounted assembly of the contact body allows the height of the relay to be limited and/or any desired height to be obtained. The contact body may, according to embodiments of the invention, also in another way resilient, hingedly or otherwise movably be hung up or mounted with respect to the carrier.

35 **[0012]** According to embodiments of the invention, the or each spring may be adapted to form an electrically

conductive path between the carrier and the contact body.

[0013] According to a possible embodiment, the carrier may have a first side on which the at least two coils and the contact body are provided and a second side, opposite to the first side, on which an invention, also in another way resilient, hingedly or otherwise movably be hung up or mounted with respect to the carrier.

[0014] According to embodiments of the invention, the or each spring may be adapted to form an electrically conductive path between the carrier and the contact body.

[0015] According to a possible embodiment, the carrier may have a first side on which the at least two coils and the contact body are provided and a second side, opposite to the first side, on which an electronic component is provided. Further, one or more electronic components can also be provided on this first side. Furthermore, one or more electronic components can be provided on one side of the contact body or on both sides thereof.

[0016] The at least one contact element is provided directly to the carrier on a side facing the contact body. In other embodiments, not claimed in this application, it can also be provided at a different location, for example at a distance from the carrier, on the other side of the contact body. The at least one contact element is provided between two adjacent coils on the carrier.

[0017] According to advantageous embodiments of the invention, at least four coils may be provided, which are placed next to each other in a plane between the carrier and the contact body. This will allow the distance between the carrier and the contact body to be kept relatively small, while the coils can exert a sufficiently large force on the contact body without very high currents being required. The distance between the carrier and the contact body, in the condition in which the at least one contact element does not make contact with the contact body, may preferably be less than 1.5 times the diameter ($1.5 \cdot d$) of a coil, more preferably smaller than the diameter of the coil, and most preferably less than 0.75 times the diameter ($0.75 \cdot d$) of the coil. This distance may preferably be less than 10 mm, or more preferably less than 5 mm.

[0018] The at least one electrical contact element may, for example, comprise a spring contact or a spherical contact. More generally, the at least one electrical contact element can have any shape. Furthermore, contact elements of different types can be combined in one relay.

[0019] According to an advantageous embodiment, the carrier and/or the contact body may be a PCB, and each coil may be formed with conductive tracks of the PCB (PCB track coil). Hereby the conductive tracks may, according to embodiments of the invention, be provided in multiple layers of the PCB. In this way, the compactness of the relay can be further enhanced.

[0020] According to an embodiment invention, each coil may be provided with a core of magnetic material. Further, each coil can also be surrounded by at least one

element of magnetic material in order to, together with the at least one coil and the contact body, form a magnetic circuit. Such an element can be mounted against the contact body or against the carrier. Furthermore, such an element can be resilient or spring-mounted. When the contact body, as a result of charging the at least one coil, moves in the direction of the carrier, such a spring element of magnetic material can then be pushed in.

[0021] The relay may comprise an additional movably mounted contact body, an additional carrier, and at least two additional coils to generate a magnetic field for moving the additional contact body with respect to the additional carrier. The contact body and the additional contact body are hereby facing each other and are located between the carrier and the additional carrier. The additional carrier may be located at a fixed distance from the carrier, and the at least one contact element may be provided on or may be formed by the additional contact body. In this way, the relay function is thus built in between two carriers, wherein two sets of coils located above each other are present between the carriers, and wherein additional electronic components can be mounted onto the carriers. The carriers may preferably be PCBs.

[0022] The relay may comprise an additional carrier at a fixed distance from the carrier. The additional carrier is provided with at least one contact element at a side facing a side of the contact body. Between the contact body and the carrier, there may be a movable intermediate body, typically a separator plate, on which or in which at least two additional coils are provided for the generation of a magnetic field to move the contact body with respect to the intermediate body. In this way, the distance between the contact body and the at least one contact element (in the open position) can be increased. Also two sets of coils, which contribute to the movement of the contact body with respect to the carrier, are provided above each other. Furthermore, other electronic components can be provided on both the carrier and the additional carrier.

[0023] According to a possible embodiment, the at least one contact element may comprise at least a first contact element on a first side of the contact body and at least a second contact element on a second side of the contact body, and the contact body may be mounted and designed so as to make electrical contact with the first contact element in a first position and with the second contact element in a second position. In this way, a two-way circuit can be formed, in which the contact body alternately makes contact with the first contact element and the second contact element.

[0024] According to a possible embodiment, the contact body may be movable between a first and a second position as a result of the generation of respectively a first and a second magnetic field by means of the at least two coils. This is called a bi-stable relay. To obtain a bi-stable relay, at least one permanent magnet may be provided onto the carrier and/or the contact body in such a way that the contact body is kept in the first position after

removal of the first magnetic field and/or that the contact body is kept in the second position after removal of the second magnetic field. According to embodiments of the invention, the contact body may be spring-mounted with respect to the carrier by means of at least one bi-stable spring element, whereby the at least one bi-stable spring element is mounted in such a way that the contact body is kept in the first position after removal of the first magnetic field and/or that the contact body is kept in the second position after removal of the second magnetic field.

[0025] According to a further developed embodiment, the at least one contact element may comprise a first contact element and a second contact element, and the at least two coils are provided in such a way that, as a result of selectively charging one or more of these coils, the first and second contact element can selectively make contact with the contact body. In this way, compact multiple relays can be built.

[0026] The present invention will be further explained on the basis of a number of, by no means limiting, exemplary embodiments of an electromechanical relay according to the invention, with reference to the attached drawings.

Figure 1A schematically illustrates an exploded perspective view of a first embodiment of a relay according to the invention;

Figure 1B schematically illustrates a side view of the embodiment of figure 1A;

Figure 1C schematically illustrates a top view of the embodiment of figure 1A;

Figure 2 schematically illustrates a perspective view of a second embodiment of a relay;

Figure 3 schematically illustrates a perspective view of a third embodiment of a relay;

Figure 4 schematically illustrates an exploded perspective view of a fourth embodiment of a relay according to the invention;

Figure 5 schematically illustrates a perspective view of a fifth embodiment of a relay according to the invention;

Figure 6 schematically illustrates a perspective view of a sixth embodiment of a relay according to the invention;

Figure 7 schematically illustrates a perspective view of a seventh embodiment of a relay according to the invention;

Figures 8A and 8B schematically illustrate a view of a bi-stable spring element in two different positions; and

Figures 9A and 9B schematically illustrate a view of an embodiment of a relay according to the invention in two different positions.

[0027] A first embodiment of an electromechanical relay according to the invention is shown in figures 1A-1C. The relay comprises a carrier 4 onto which a number of coils 1 are mounted. According to the present embodiment,

the carrier 4 may be implemented in the form of a PCB 4. The coils 1 are positioned next to each other onto the PCB 4 and in a plane parallel to the PCB 4. In the illustrated example, sixteen coils 1 have been provided. It has to be understood by a person skilled in the art that this number is not meant to be limiting in any way, a relay according to embodiments of the invention can have any number of coils 1 as required for the relevant application. A contact body 3 is movably mounted with respect to PCB 4 by means of a number of springs 5. According to the present embodiment, the contact body 3 may be provided in the form of a contact plate 3 made out of a magnetic material, for example an iron alloy. According to further embodiments of the invention which have not been illustrated, the contact body 3 may be a PCB on which or in which one or more permanent magnets are provided. Each of the at least one coil (1) may have an axis that is oriented perpendicular to the carrier (4) and/or the contact body (3). In the illustrated example, four springs 5 are provided in between PCB 4 and contact plate 3 at the corners of the PCB 4 and the contact plate 3. A person skilled in the art will understand that, according to embodiments of the invention, more or less than four springs 5 may be provided, and that the springs 5 can be provided at other positions than in the corners. These springs 5 may, according to some embodiments of the invention, also have an additional function, for example the function of an electrical conduction between the contact plate 3 and a conductive path on PCB 4 which is connected to an electronic component 6 that is mounted on PCB 4. In order to keep the distance between contact plate 3 and PCB 4 small, the ends of the springs 5 may preferably be attached directly to contact plate 3 at the one end and to PCB 4 at the other end.

[0028] The relay furthermore comprises a number of electrical contact elements, here in the form of a pillar-shaped electrically conductive element 2a and four electrically conductive spring elements 2b. These contact elements 2a, 2b are intended to make contact with the contact plate 3 in the closed position of the relay. Providing a current through the coils 1 allows for a movement of the contact plate 3 in the direction of the carrier 4, in order to establish an electrical contact between contact plate 3 and contact elements 2a, 2b. According to embodiments of the invention that have not been illustrated, it is also possible that the relay is originally closed (i.e. that an electrical contact is present between contact plate 3 and contact elements 2a, 2b) and that charging the coils 1 causes the movement of the contact plate 3 away from the carrier 4 in such a way that the electrical contact is disconnected.

[0029] In the present embodiment, the coils 1 are provided on a flat top surface of PCB 4, but, according to alternative embodiments, the coils 1 may also be provided in cavities in the PCB 4 or as conductive tracks of PCB 4 in the shape of so-called PCB track coils.

[0030] In the embodiment illustrated in figures 1A-1C, the coils 1 and the contact plate 3 are provided on a top

side 41 of PCB 4, and the bottom side 42 of PCB 4 is intended for mounting additional electronic components 6. However, it is also possible to provide additional electronic components 6 at the top side 41 of PCB 4 or at the top or bottom of contact plate 3, see also the embodiment of figure 4 which is discussed below.

[0031] The distance D (see figure 1B) between PCB 4 and contact plate 3 may preferably be relatively small, for example less than 5 mm in the condition in which the contact elements 2a, 2b do not make contact with the contact plate 3, in such a way that a thin compact unit is obtained. The distance D between PCB 4 and contact plate 3 may preferably be less than 1.5 times the diameter d (1.5*d) of the coil 1, more preferably smaller than the diameter d of the coil 1, and most preferably less than 0.75 times the diameter d (0.75*d) of the coil 1.

[0032] According to embodiments of the invention, the coils 1 can be provided with a core of magnetic material. Further, the coils 1 can be surrounded by at least one element of magnetic material to close the magnetic circuit. In the example of figures 1A-1C, each coil 1 may be surrounded by four beam-shaped elements 8 of magnetic material. Further, instead of four beam-shaped elements 8, according to embodiments of the invention, also one tubular element 8 can be provided around a coil 1 (see also figure 4), and these elements 8 could also be attached to the contact plate 3 instead of to PCB 4.

[0033] The relay illustrated in figures 1A-C is a so-called monostable relay, i.e. a relay of which the contact body 3 during charging of the coils 1 is kept in a first position (here a closed position) and springs back to a second position (here the open position) at the time that the charge is removed. It is, however, also possible to build the relay of figures 1A-C as a so-called bi-stable relay, i.e. a relay of which the coils 1 can move the contact body 3 from a first position to a second position and vice versa (for example, by reversing the direction of the current sent through the coils 1), and of which the contact body 3 after the removal of the charge stays in the relevant position. For this purpose, one or more springs 5 can be implemented as so-called bi-stable spring elements, i.e. spring elements that after spring rebound or compression remain in the rebound or compressed position, respectively. An example of such a spring element 5 is a leaf spring, which shows a buckling phenomenon during the spring rebound and compression. According to embodiments of the present invention, such a bi-stable spring element can easily be provided in the contact body 3, as is illustrated in figures 8A and 8B. The bi-stable spring elements 15 are formed by cutting out zones of the contact plate 3 and by creating a permanent bending deformation via a narrow bridge zone. According to typical embodiments, the contact plate 3 may be sufficiently thin and/or elastic so that the bending deformed zone will, when a point force is applied, jump to the other side of the contact plate 3. Figures 8A and 8B illustrate one bi-stable spring element 15, but a person skilled in the art will understand that several such spring elements 15

can be installed. Figures 9A and 9B illustrate the operation of such a bi-stable spring element 15. Figure 9A illustrates the open position. When the contact plate 3 is attracted as a result of a magnetic field generated by the coil 1, the bi-stable spring element 15 is pressed against the carrier 4, and it will jump to its reversed fixed position, see figure 9B. The bi-stable spring element 15 will hereby make contact with an opposite stop 16, such that the contact plate 3 is pushed against the contact elements 2a. The contact plate 3 will remain in this position until again a magnetic field is generated that ensures that the contact plate 3 is moved up, away from the contact elements 2a. At that time, the bi-stable spring element 15 returns to the position of figure 9A. According to a further embodiment that is not illustrated, the bi-stable spring elements 15 can also be provided on the carrier 4.

[0034] According to embodiments of the invention, one or more permanent magnets (not shown in figures 1A-C) can be provided on the carrier 4. To allow movement of the contact body 3 from the closed position to the open position, the coils 1 are charged in such a way that the magnetic force that is generated can overcome the magnetic force of the permanent magnets in order to move the contact body 3 from the closed position to the open position. This may, for example, be achieved by sending a sufficiently high current in the reverse direction (in comparison with the direction needed to move the contact body 3 from the open to the closed position) through the coils 1.

[0035] Although in the description above, it was described to charge the coils 1 simultaneously so as to move the contact body 3 from a closed position to an open position and vice versa, a person skilled in the art will understand that it is also possible to charge the coils not simultaneously, so that the contact body 3 is, for example, tilted, and not all contacts are closed. The contact elements 2a, 2b do not have to be electrically connected to each other, and the separate control of the coils 1 will then allow the selective contact of the contact elements 2a, 2b with the contact body 3 so that multiple independent switching electrical circuits can be realized. This will make multi-switch actions possible, and it will, for example, be possible to obtain an electrical two-way circuit.

[0036] Figure 2 illustrates a second embodiment of a relay. Similar parts have been indicated with the same reference numbers as in figure 1. The relay comprises, similar to the relay illustrated in figure 1, a contact body in the form of a contact plate 3, a carrier in the form of a PCB 4 and at least one coil 1, in the example given a plurality of coils 1, provided on the PCB 4. According to the second embodiment, an additional movably mounted contact plate 3', an additional carrier in the form of PCB 4' and at a fixed distance from PCB 4, and a number of additional coils 1' for the generation of a magnetic field to move the additional contact plate 3' with respect to additional PCB 4', are provided. The additional coils 1' are provided on the additional PCB 4'. Contact plate 3 and additional contact plate 3' are facing each other and

are located between PCB 4 and PCB 4'. The at least one electrical contact element is formed here as a number of contact paths 2c which are provided on the additional contact plate 3' on a side facing the contact plate 3. According to the present embodiment, both coils 1 and additional coils 1' will contribute to the movement toward each other of contact plate 3 and additional contact plate 3'. In this way, the distance between the contact body 3 and the contact elements 2 can be increased. Furthermore, both the top side of PCB 4' and the bottom side of PCB 4 are available for mounting electronic components 6 thereon.

[0037] The relay illustrated in figure 2 is a monostable relay. It is, however, also possible to build the variant of figure 2 as a so-called bi-stable relay. For this purpose, one or more springs 5 can be implemented as so-called bi-stable spring elements, as described for the embodiment of figure 1 and as illustrated in figures 8A, 8B, 9A and 9B.

[0038] Also for the variant of figure 2, the coils 1 and 1' can be charged simultaneously or separately, or group by group (for example, four at a time), depending on whether it is desirable to obtain a single or a composed multiple relay.

[0039] Figure 3 illustrates a third embodiment of a relay. Similar parts have been indicated with the same reference numbers as in figure 1. The relay comprises, similar to the relay illustrated in figure 1, a contact body in the form of a contact plate 3, a carrier in the form of a PCB 4 and at least one coil 1, in the example given a plurality of coils 1. According to the third embodiment, an additional PCB 4' is provided at a fixed distance from PCB 4. The contact plate 3 is provided in between the PCB 4 and the additional PCB 4 and at least one contact element 2d is provided on the additional PCB 4' on a side facing a side of the contact plate 3. Between the contact plate 3 and PCB 4, a movably mounted intermediate plate 7, for example a PCB 7, is provided onto which a plurality of coils 1" are mounted for the generation of a magnetic field to move contact plate 3 with respect to the intermediate plate 7. In this way, both coils 1 and 1" will contribute to the movement of contact plate 3 in the direction of the electrical contact elements 2d. Furthermore, both the top side of PCB 4' and the bottom side of PCB 4 are available for mounting electronic components 6 thereon.

[0040] The relay illustrated in figure 3 is a monostable relay. It is, however, also possible to build the variant of figure 3 as a so-called bi-stable relay. For this purpose, one or more springs 5a, 5b can be implemented as so-called bi-stable spring elements, as described for the embodiment of figure 1. According to embodiments of the invention, permanent magnets can further be mounted on the bottom side of PCB 4', see also the embodiment of figure 6.

[0041] Also for the variant of figure 3, the coils 1 and 1" can be charged simultaneously or separately, or group by group (for example, two or four at a time), depending on whether it is desirable to obtain a single or a composed

multiple relay.

[0042] Figure 4 illustrates a fourth embodiment of a relay according to the invention. Similar parts have been indicated with the same reference numbers as in figure 1. According to the fourth embodiment, the contact body is formed by a frame-shaped PCB 3. At the bottom side of PCB 3, a number of zones 18 of magnetic material are provided, which zones 18 extend above the coils 1 which are provided on the carrier 4. Furthermore, PCB 3 is provided with additional contact elements 13 formed of electrically conductive material, which are intended to make contact with electrical contact elements 2b, here implemented as spring contacts, on PCB 4. According to the fourth embodiment, the coils 1 are provided on PCB 4 at a distance from each other, and additional electrical components 6, 6", 6''' are provided on the top side and/or bottom side of PCB 4. Furthermore, the opening in frame-shaped PCB 3 allows a high electronic component 6" to be provided on PCB 4, as this component 6" can stick out through the opening. Furthermore, electrical components 6', 6''' can for example also be provided on the bottom and the top of PCB 3.

[0043] The monostable relay illustrated in figure 4 can also be built as a so-called bi-stable relay, as described in the embodiment of figure 1.

[0044] Also for the variant of figure 4, the coils 1 can be charged simultaneously or separately, or in groups, depending on whether it is desirable to obtain a single or a composed multiple relay. The two coils 1 on the left can, for example, be charged simultaneously in order to realize a contact between contact elements 2b, 13 on the left, and the two coils 1 on the right can be charged simultaneously in order to realize a contact between contact elements 2b, 13 on the right, wherein the coils 1 on the left and the coils 1 on the right can be charged independently from each other.

[0045] Figure 5 illustrates a fifth embodiment of a relay according to the invention. Similar parts have been indicated with the same reference numbers as in figure 1. According to the fifth embodiment, the coils 1 are relatively high and slim compared to the rather flat coils of the embodiments illustrated in figures 1 to 4. The springs 5 are here implemented as windings around the coils 1. In this way, a space is created between PCB 3 and PCB 4, where relatively high electronic components 6 can be provided. The contact elements are not illustrated, but may, for example, be similar to those of figures 1A-C or those of figure 4.

[0046] Figure 6 illustrates a sixth embodiment of a relay according to the invention. Similar parts have been indicated with the same reference numbers as in figure 1. According to the sixth embodiment, an additional PCB 4' is provided at a fixed distance of PCB 4. The at least one electrical contact element is here implemented as a number of contact paths 2a, 2d, which are provided on the top side 41 of PCB 4 and at the bottom side of additional PCB 4', respectively. These contact paths 2a, 2d are intended to cooperate with corresponding contact

paths 13a, 13d at respectively the bottom and top of contact body 3. Both the top of PCB 4' and the bottom of PCB 4 are available for mounting electronic components 6 thereon.

[0047] The relay furthermore comprises springs 5. According to a first possibility, the springs 5 may be such that the contact paths 13d in a first position of rest make contact with contact paths 2d. By charging coils 1, contact plate 3 can be moved to a second position in which the contact paths 13a make contact with the contact paths 2a. In this way, a two-way circuit can be realized.

[0048] According to a second possibility, which is illustrated in figure 6, the springs 5 are such that the contact paths 13d in an intermediary position do not make contact with contact paths 2d and that the contact paths 13a do not make contact with the contact paths 2a. By charging the coils 1 in respectively a first direction and a second direction opposite to the first direction, the contact plate 3 can be moved to a first position in which the contact paths 13d make contact with the contact paths 2d, and to a second position in which the contact paths 13a make contact with the contact paths 2a. Further, permanent magnets 9 may be provided at the bottom of additional PCB 4' and/or at the top of PCB 4 in order to keep the contact plate 3 in the first or second position in case of removal of the charge.

[0049] Figure 7 illustrates a seventh embodiment of a relay according to the invention. Similar parts have been indicated with the same reference numbers as in figure 1. The relay according to the seventh embodiment comprises:

- an additional PCB 4' at a fixed distance from PCB 4;
- an additional contact plate 3' spring-mounted with respect to PCB 4' by means of springs 5', at the bottom thereof; and
- additional coils 1' for moving contact plate 3' with respect to PCB 4'.

The contact plate 3 and additional contact plate 3' are provided in between the PCB 4 and PCB 4' and are facing each other. The at least one electrical contact element is here implemented as a number of contact paths 2a, 2a', which are provided on the top side 41 of PCB 4 and at the bottom side of additional PCB 4'. These contact paths 2a, 2a' are intended to cooperate with corresponding contact paths 13a, 13a' at the bottom of contact plate 3 and the top of contact plate 3', respectively. Further, the bottom side of contact plate 3' and the top side of contact plate 3 are provided with contact paths 13b', 13b respectively. Both the top side of PCB 4' and the bottom side of PCB 4 are available for mounting electronic components 6 thereon.

[0050] The springs 5, 5' may be such that the contact paths 13b in an intermediary position do not make contact with contact paths 13b' and that the contact paths 13a, 13a' do not make contact with the contact paths 2a, 2a' (situation illustrated in figure 7). By charging the coils 1

in a first direction and a second direction opposite to the first direction, respectively, the contact plate 3 can be moved to a first position in which the contact paths 13a make contact with the contact paths 2a, and to a second position in which the contact paths 13b make contact with the contact paths 13b'. By charging the coils 1' in a first and a second opposite direction, respectively, the contact plate 3' can be moved to a first position in which the contact paths 13a' make contact with the contact paths 2a', and to a second position in which the contact paths 13b make contact with the contact paths 13b'. Further, the coils 1, 1' can be charged simultaneously or separately. A person skilled in the art will understand that in this way a plurality of switch combinations can be realized with a very compact relay.

[0051] Similar as in the embodiment described with respect to, for example, figures 3 and 4, both the top of PCB 4' and the bottom of PCB 4 are available for mounting electronic components 6 thereon.

[0052] If in the embodiment illustrated in figure 7 the coils 1, 1' are charged alternately in order to selectively close or open certain contacts, the contact plates 3, 3' will in certain situations take a tilted position. In order to realize a proper contact in such a position as well, the contact elements 2a, 2a', 13a, 13a', 13b, 13b' can, for example, have a rounded shape, as schematically shown in figure 7.

[0053] The above-described electrical contact elements 2a, 2a', 2b, 2c, 2d, can, by means of conductive tracks on the PCB 4, be connected to a circuit in which the relay function should be provided. Similarly, contact plate 3 (first, second, third and fifth embodiment) or contact elements 13, 13a, 13a', 13b, 13b' (fourth, sixth and seventh embodiment) can, by means of a conductive wire or track, be connected to the circuit in which the relay function is required. This circuit can partially or fully be provided onto a carrier/PCB 4, 4' or a contact body/PCB 3.

[0054] In the illustrated embodiments, the coils 1 are always mounted to or in a fixed carrier in the shape of PCB 4 or additional carrier in the shape of PCB 4'. However, it is also possible to mount the coils 1 onto or in the contact body 3 or additional contact body 3' and to install the necessary magnetic zones 18 on or in PCB 4 or PCB 4'.

[0055] A person skilled in the art will understand that different embodiments can be combined with each other. For example, the frame-shaped contact plate of figure 4 can also be used in the embodiments of figures 1A-C, 2, 3, 5, 6, 7, where the contact elements should of course be provided in locations that have been adapted to the electrically conductive zone(s) of the contact body/PCB 3.

[0056] A person skilled in the art will understand that many modifications and additions are possible within the framework of the present invention, which in no way is limited by the exemplary embodiments described above. The scope of protection is only determined by the follow-

ing claims.

Claims

1. Electromechanical relay comprising:

- a carrier (4);
- a contact body (3), movably mounted with respect to the carrier (4);
- at least one electrical contact element (2a;2b;2c;2d);
- at least two coils (1) for moving the contact body (3) with respect to the carrier (4), so as to disconnect or establish an electrical contact between the contact body (3) and the at least one electrical contact element (2a;2b;2c;2d),

wherein the contact body (3) is adapted to move as a result of a magnetic field generated by the at least two coils (1), wherein the at least two coils (1) are mounted on or in the carrier (4) and/or on or in the contact body (3), and wherein the carrier (4) and/or the contact body (3)

- are made out of an electrically insulating material, on which or in which electrically conductive tracks are provided, and
- are adapted for providing electronic components (6) thereon, which electronic components (6) are connectable to the electrically conductive tracks; wherein the at least two coils (1) are placed next to each other, seen in a plane parallel to the carrier (4) and/or the contact body (3);

wherein the at least one contact element (2a;2b;2c;2d) is provided directly to the carrier (4) on a side of the carrier facing the contact body (3), **characterized in that** the at least one electrical contact element (2a;2b;2c;2d) is provided between adjacent coils on the carrier of the at least two coils (1).

2. Electromechanical relay according to claim 1, wherein the carrier (4) and/or the contact body (3) is a printed circuit board (PCB).
3. Electromechanical single relay according to claim 1 or 2, wherein the at least one electrical contact comprises a spring contact or a spherical contact.
4. Electromechanical relay according to any of the previous claims, wherein the or each coil (1) has an axis that is oriented perpendicular to the carrier (4) and/or the contact body (3).
5. Electromechanical relay according to any of the previous claims, wherein the contact body (3)

- has been fully made out of a magnetic material; or
- comprises zones (18) of magnetic material; and/or
- is provided with one or more permanent magnets (9).

6. Electromechanical relay according to any of the previous claims, wherein at least one spring means (5;5a,5b) is provided between the carrier (4) and the contact body (3).

7. Electromechanical relay according to claim 6, wherein the or each spring means (5;5a,5b) has a first end that is attached to the carrier (4) and a second end that is attached to the contact body (3).

8. Electromechanical relay according to claim 6 or 7, wherein the or each spring means (5;5a,5b) is adapted to form an electrically conductive path between the carrier (4) and the contact body (3).

9. Electromechanical relay according to any of the previous claims, the carrier (4) having a first side (41) and a second side (42) and the contact body (3) having a first side and a second side, wherein an electronic component (6,6",6""") is mounted on the first side (41) and/or on the second side (42) of the carrier (4); and/or wherein an electronic component (6',6'") is mounted on the first and/or on the second side of the contact body (3).

10. Electromechanical relay according to any of the previous claims, wherein the distance (D) between the carrier (4) and the contact body (3), in the condition in which the at least one contact element (2a;2b;2c;2d) does not make contact with the contact body (3), is less than 5 mm.

11. Electromechanical relay according to any one of the previous claims, wherein the distance between the carrier and the contact body, in the condition in which the at least one contact element does not make contact with the contact body, is smaller than the diameter of the coil.

12. Electromechanical relay according to any of the previous claims, wherein the at least one contact element comprises at least a first contact element (2a) on a first side of the contact body (3) and a second contact element (2d; 13b') on a second side of the contact body (3), and the contact body (3,13a, 13d; 3, 13a, 13b) is mounted and adapted to make electrical contact with the first contact element (2a) in a first position and with the second contact element (2d; 13b') in a second position.

13. Electromechanical relay according to any of the previous claims, wherein the contact body (3) is movable between a first and a second position as a result of the generation of respectively a first and a second magnetic field by the at least two coils (1), and at least one permanent magnet (9) is provided on the carrier (4) and/or the contact body (3) in such a way that the contact body (3) is kept in the first position after removal of the first magnetic field and/or that the contact body (3) is kept in the second position after removal of the second magnetic field.
14. Electromechanical relay according to any of the previous claims, wherein the at least one contact element comprises a first contact element and a second contact element, and the at least two coils (1) are provided in such a way that, as a result of selectively charging one or more coils (1), the first and second contact element can selectively make contact with the contact body (3).

Patentansprüche

1. Elektromechanisches Relais, umfassend:

- einen Träger (4);
- einen Kontaktkörper (3), beweglich in Bezug auf den Träger (4) montiert;
- wenigstens ein elektrisches Kontaktelement (2a; 2b; 2c; 2d);
- wenigstens zwei Spulen (1) zum Bewegen des Kontaktkörpers (3) in Bezug auf den Träger (4), um einen elektrischen Kontakt zwischen dem Kontaktkörper (3) und dem wenigstens einen elektrischen Kontaktelement (2a; 2b; 2c; 2d) zu trennen oder herzustellen,

wobei der Kontaktkörper (3) angepasst ist, um sich aufgrund eines Magnetfelds, welches durch die wenigstens zwei Spulen (1) erzeugt wurde, zu bewegen, wobei die wenigstens zwei Spulen (1) an oder in dem Träger (4) und/oder an oder in dem Kontaktkörper (3) montiert sind, und wobei der Träger (4) und/oder der Kontaktkörper (3)

- aus einem elektrisch isolierenden Material gefertigt sind, an welchem oder in welchem elektrisch leitende Spuren bereitgestellt sind, und
- zum Bereitstellen von elektronischen Komponenten (6) darauf angepasst sind, wobei die elektronischen Komponenten (6) mit den elektrisch leitenden Spuren verbunden werden können;

wobei die wenigstens zwei Spulen (1) nebeneinander angeordnet sind, gesehen in einer Ebene parallel zum Träger (4) und/oder dem Kontaktkörper (3);

wobei das wenigstens eine Kontaktelement (2a; 2b; 2c; 2d) direkt zu dem Träger (4) auf einer Seite des Trägers, die dem Kontaktkörper (3) zugewandt ist, bereitgestellt ist; **dadurch gekennzeichnet, dass** das wenigstens eine elektrische Kontaktelement (2a; 2b; 2c; 2d) zwischen benachbarten Spulen an dem Träger der wenigstens zwei Spulen (1) bereitgestellt ist.

2. Elektromechanisches Relais nach Anspruch 1, wobei der Träger (4) und/oder der Kontaktkörper (3) eine Leiterplatte (PCB) ist.

3. Elektromechanisches Relais nach Anspruch 1 oder 2, wobei der wenigstens eine elektrische Kontakt einen Federkontakt oder einen Kugelkontakt umfasst.

4. Elektromechanisches Relais nach einem der vorhergehenden Ansprüche, wobei die oder jede Spule (1) eine Achse aufweist, die senkrecht zu dem Träger (4) und/oder dem Kontaktkörper (3) orientiert ist.

5. Elektromechanisches Relais nach einem der vorhergehenden Ansprüche, wobei der Kontaktkörper (3)

- vollständig aus einem Magnetmaterial gefertigt wurde; oder
- Zonen (18) von magnetischem Material umfasst; und/oder
- Mit einen oder mehrere Permanentmagneten (9) bereitgestellt ist.

6. Elektromechanisches Relais nach einem der vorhergehenden Ansprüche, wobei wenigstens eine Federeinrichtung (5; 5a, 5b) zwischen dem Träger (4) und dem Kontaktkörper (3) bereitgestellt ist.

7. Elektromechanisches Relais nach Anspruch 6, wobei die oder jede Federeinrichtung (5; 5a, 5b) ein erstes Ende aufweist, das an dem Träger (4) befestigt ist, und ein zweites Ende, das an dem Kontaktkörper (3) befestigt ist.

8. Elektromechanisches Relais nach Anspruch 6 oder 7, wobei die oder jede Federeinrichtung (5; 5a, 5b) angepasst ist, um einen elektrisch leitenden Pfad zwischen dem Träger (4) und dem Kontaktkörper (3) zu bilden.

9. Elektromechanisches Relais nach einem der vorhergehenden Ansprüche, wobei der Träger (4) eine erste Seite (41) und eine zweite Seite (42) aufweist und der Kontaktkörper (3) eine erste Seite und eine zweite Seite aufweist,

wobei eine elektronische Komponente (6, 6', 6'') an der ersten Seite (41) und/oder an der zweiten Seite (42) des Trägers (4) montiert ist; und/oder wobei eine elektronische Komponente (6', 6'') an der

ersten Seite und/oder an der zweiten Seite des Kontaktkörpers (3) montiert ist.

10. Elektromechanisches Relais nach einem der vorhergehenden Ansprüche, wobei der Abstand (D) zwischen dem Träger (4) und dem Kontaktkörper (3) in dem Zustand, in welchem das wenigstens eine Kontaktelement (2a; 2b; 2c; 2d) keinen Kontakt mit dem Kontaktkörper (3) herstellt, weniger als 5 mm beträgt.

11. Elektromechanisches Relais nach einem der vorhergehenden Ansprüche, wobei der Abstand zwischen dem Träger und dem Kontaktkörper in dem Zustand, in welchem das wenigstens eine Kontaktelement keinen Kontakt mit dem Kontaktkörper herstellt, kleiner ist als der Durchmesser der Spule.

12. Elektromechanisches Relais nach einem der vorhergehenden Ansprüche, wobei das wenigstens eine Kontaktelement wenigstens ein erstes Kontaktelement (2a) an einer ersten Seite des Kontaktkörpers (3) und ein zweites Kontaktelement (2d; 13b') an einer zweiten Seite des Kontaktkörpers (3) umfasst und der Kontaktkörper (3, 13a, 13d; 3, 13a, 13b) montiert und angepasst ist, um mit dem ersten Kontaktelement (2a) in einer ersten Position und mit dem zweiten Kontaktelement (2d; 13b') in einer zweiten Position elektrischen Kontakt herzustellen.

13. Elektromechanisches Relais nach einem der vorhergehenden Ansprüche, wobei der Kontaktkörper (3) zwischen einer ersten und einer zweiten Position aufgrund der Erzeugung eines ersten bzw. eines zweiten Magnetfelds durch die wenigstens zwei Spulen (1) beweglich ist und wenigstens ein Permanentmagnet (9) an dem Träger (4) und/oder dem Kontaktkörper (3) auf eine derartige Weise bereitgestellt ist, dass der Kontaktkörper (3) nach Entfernung des ersten Magnetfelds in der ersten Position gehalten wird und/oder dass der Kontaktkörper (3) nach Entfernung des zweiten Magnetfelds in der zweiten Position gehalten wird.

14. Elektromechanisches Relais nach einem der vorhergehenden Ansprüche, wobei das wenigstens eine Kontaktelement ein erstes Kontaktelement und ein zweites Kontaktelement umfasst und die wenigstens zwei Spulen (1) auf eine derartige Weise bereitgestellt sind, dass, aufgrund von selektivem Laden von einer oder mehreren Spulen (1), das erste und zweite Kontaktelement selektiv Kontakt mit dem Kontaktkörper (3) herstellen können.

Revendications

1. Relais électromécanique comprenant :

- un support (4) ;
- un corps de contact (3), monté de manière mobile par rapport au support (4);
- au moins un élément de contact électrique (2a ; 2b ; 2c ; 2d);
- au moins deux bobines (1) pour déplacer le corps de contact (3) par rapport au support (4), de manière à déconnecter ou à établir un contact électrique entre le corps de contact (3) et l'au moins un élément de contact électrique (2a ; 2b ; 2c ; 2d),

dans lequel le corps de contact (3) est adapté pour se déplacer sous l'effet d'un champ magnétique généré par les au moins deux bobines (1), dans lequel les au moins deux bobines (1) sont montées sur ou dans le support (4) et/ou sur ou dans le corps de contact (3), et dans lequel le support (4) et/ou le corps de contact (3)

- sont constitués d'un matériau électriquement isolant, sur lequel ou dans lequel sont disposées des pistes électro-conductrices, et
- sont adaptés pour fournir des composants électroniques (6) sur ceux-ci, lesquels composants électroniques (6) sont connectables aux pistes électro-conductrices ;

dans lequel les au moins deux bobines (1) sont placées l'une à côté de l'autre, vu dans un plan parallèle au support (4) et/ou au corps de contact (3) ; dans lequel l'au moins un élément de contact (2a ; 2b ; 2c ; 2d) est disposé directement sur le support (4) sur un côté du support face au corps de contact (3), **caractérisé en ce que** l'au moins un élément de contact électrique (2a ; 2b ; 2c ; 2d) est disposé entre des bobines adjacentes sur le support des au moins deux bobines (1).

2. Relais électromécanique selon la revendication 1, dans lequel le support (4) et/ou le corps de contact (3) est une carte de circuit imprimé (PCB).
3. Relais électromécanique selon la revendication 1 ou 2, dans lequel l'au moins un contact électrique comprend un contact à ressort ou un contact sphérique.
4. Relais électromécanique selon l'une quelconque des revendications précédentes, dans lequel la ou chaque bobine (1) a un axe qui est orienté perpendiculairement au support (4) et/ou au corps de contact (3).
5. Relais électromécanique selon l'une quelconque des revendications précédentes, dans lequel le corps de contact (3)

- a été entièrement fabriqué d'un matériau

- magnétique ; ou
 - comprend des zones (18) de matériau magnétique ; et/ou
 - est pourvu d'un ou plusieurs aimants permanents (9).
6. Relais électromécanique selon l'une quelconque des revendications précédentes, dans lequel au moins un moyen à ressort (5 ; 5a, 5b) est disposé entre le support (4) et le corps de contact (3).
7. Relais électromécanique selon la revendication 6, dans lequel le ou chaque moyen à ressort (5 ; 5a, 5b) a une première extrémité qui est fixée au support (4) et une seconde extrémité qui est fixée au corps de contact (3).
8. Relais électromécanique selon la revendication 6 ou 7, dans lequel le ou chaque moyen à ressort (5 ; 5a, 5b) est adapté pour former un chemin électro-conducteur entre le support (4) et le corps de contact (3).
9. Relais électromécanique selon l'une quelconque des revendications précédentes, le support (4) ayant un premier côté (41) et un second côté (42) et le corps de contact (3) ayant un premier côté et un second côté,
 dans lequel un composant électronique (6, 6", 6''') est monté sur le premier côté (41) et/ou sur le second côté (42) du support (4) ; et/ou
 dans lequel un composant électronique (6', 6''') est monté sur le premier et/ou sur le second côté du corps de contact (3).
10. Relais électromécanique selon l'une quelconque des revendications précédentes, dans lequel la distance (D) entre le support (4) et le corps de contact (3), dans la condition dans laquelle l'au moins un élément de contact (2a ; 2b ; 2c ; 2d) ne fait pas contact avec le corps de contact (3), est inférieure à 5 mm.
11. Relais électromécanique selon l'une quelconque des revendications précédentes, dans lequel la distance entre le support et le corps de contact, dans la condition dans laquelle l'au moins un élément de contact ne fait pas contact avec le corps de contact, est inférieure au diamètre de la bobine.
12. Relais électromécanique selon l'une quelconque des revendications précédentes, dans lequel l'au moins un élément de contact comprend au moins un premier élément de contact (2a) sur un premier côté du corps de contact (3) et un second élément de contact (2d ; 13b') sur un second côté du corps de contact (3), et le corps de contact (3, 13a, 13d ; 3, 13a, 13b) est monté et adapté pour réaliser un contact électrique avec le premier élément de contact (2a) dans une première position et avec le second élément de contact (2d ; 13b') dans une seconde position.
13. Relais électromécanique selon l'une quelconque des revendications précédentes, dans lequel le corps de contact (3) est mobile entre une première et une seconde position sous l'effet de la génération de respectivement un premier et un second champ magnétique par les au moins deux bobines (1), et au moins un aimant permanent (9) est disposé sur le support (4) et/ou le corps de contact (3) de manière à ce que le corps de contact (3) est maintenu dans la première position après le retrait du premier champ magnétique et/ou à ce que le corps de contact (3) est maintenu dans la seconde position après le retrait du second champ magnétique.
14. Relais électromécanique selon l'une quelconque des revendications précédentes, dans lequel l'au moins un élément de contact comprend un premier élément de contact et un second élément de contact, et les au moins deux bobines (1) sont disposées de manière à ce que, sous l'effet du chargement sélectif d'une ou de plusieurs bobines (1), le premier et le second élément de contact peuvent sélectivement entrer en contact avec le corps de contact (3).

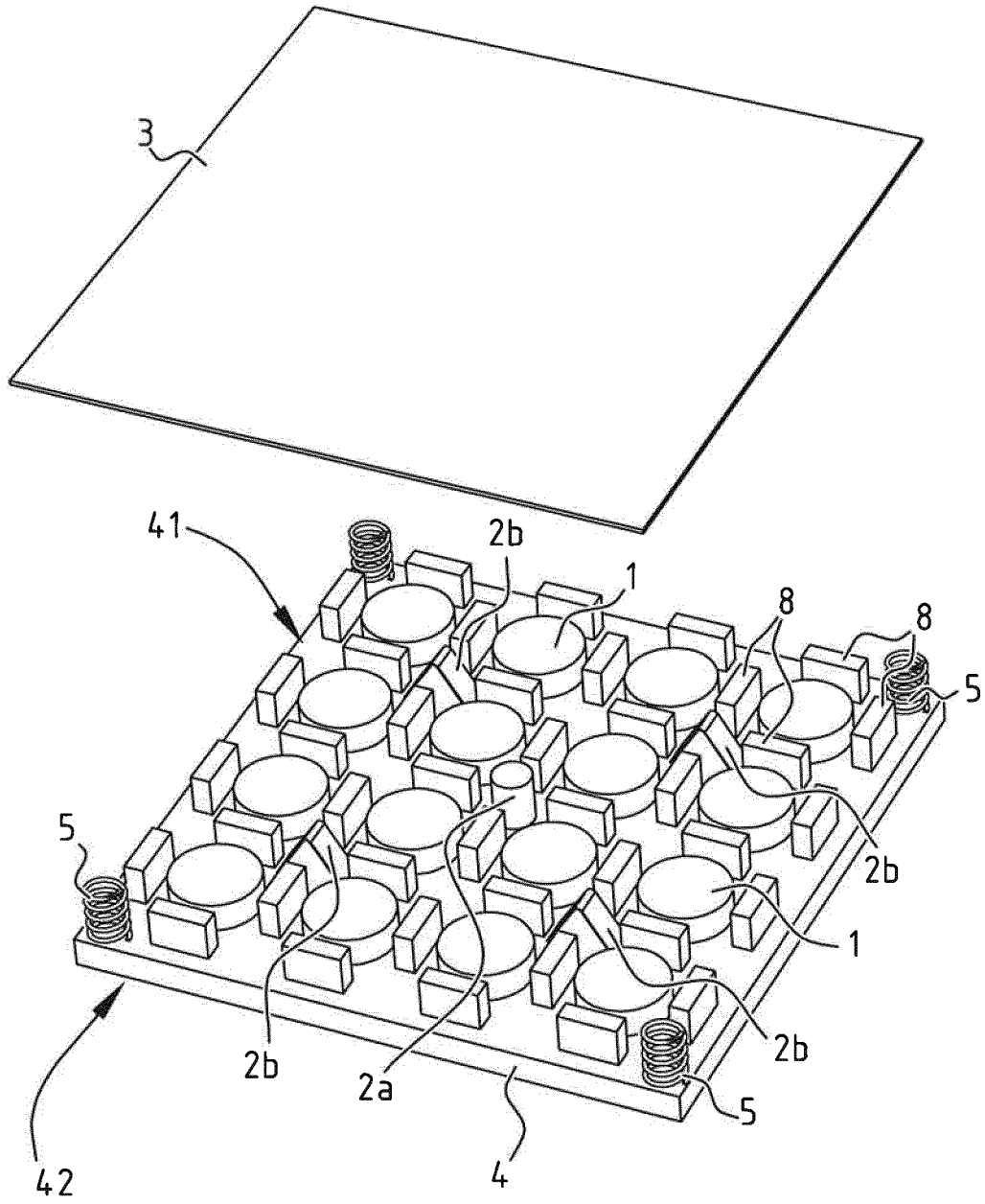

FIG. 1A

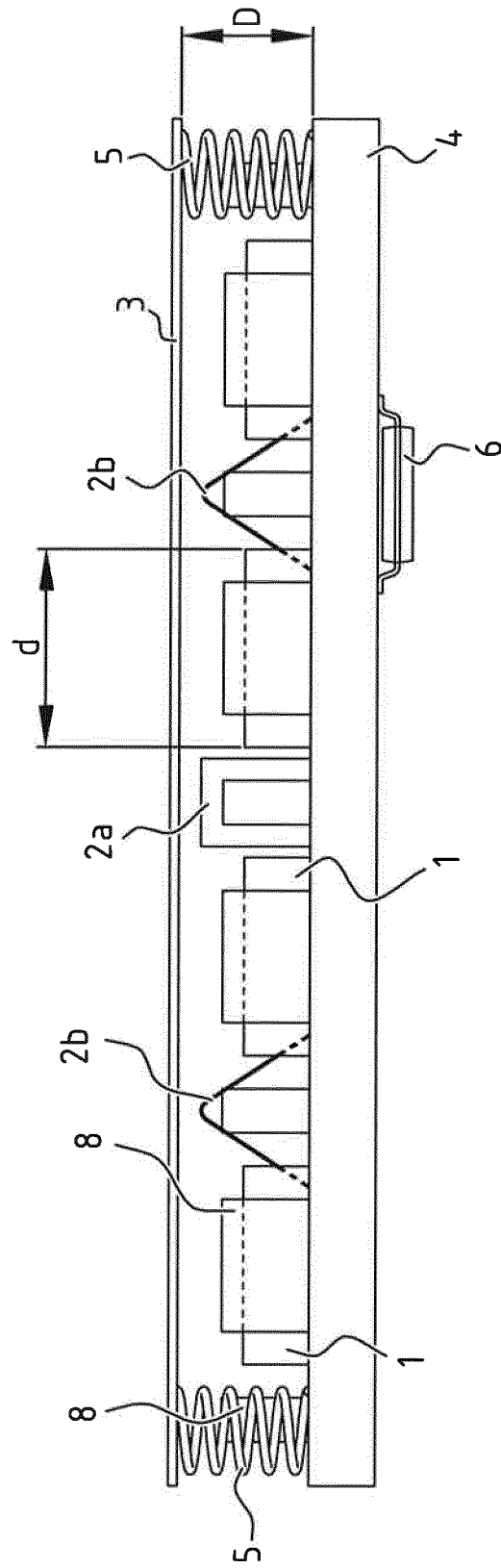

FIG. 1B

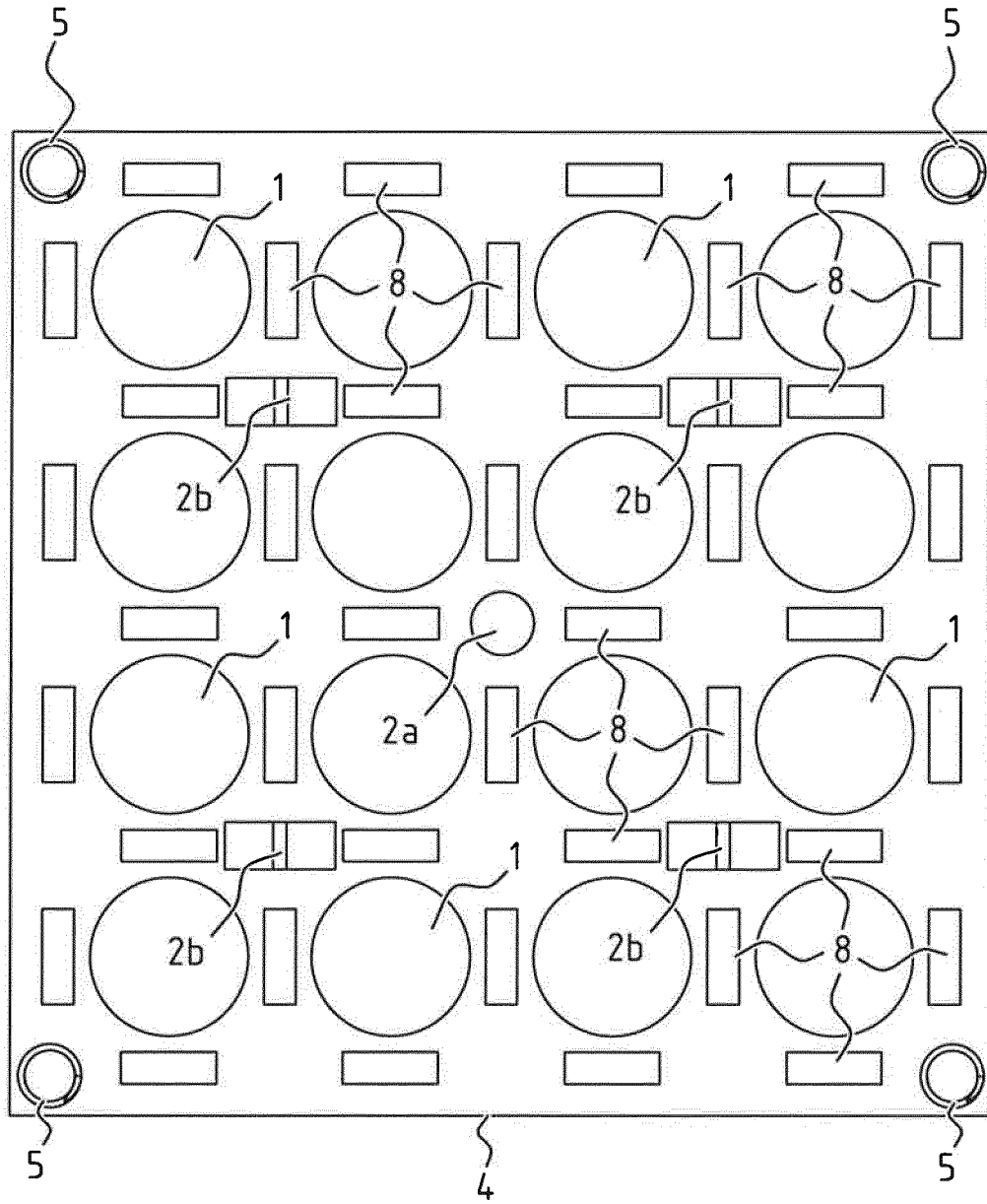

FIG. 1C

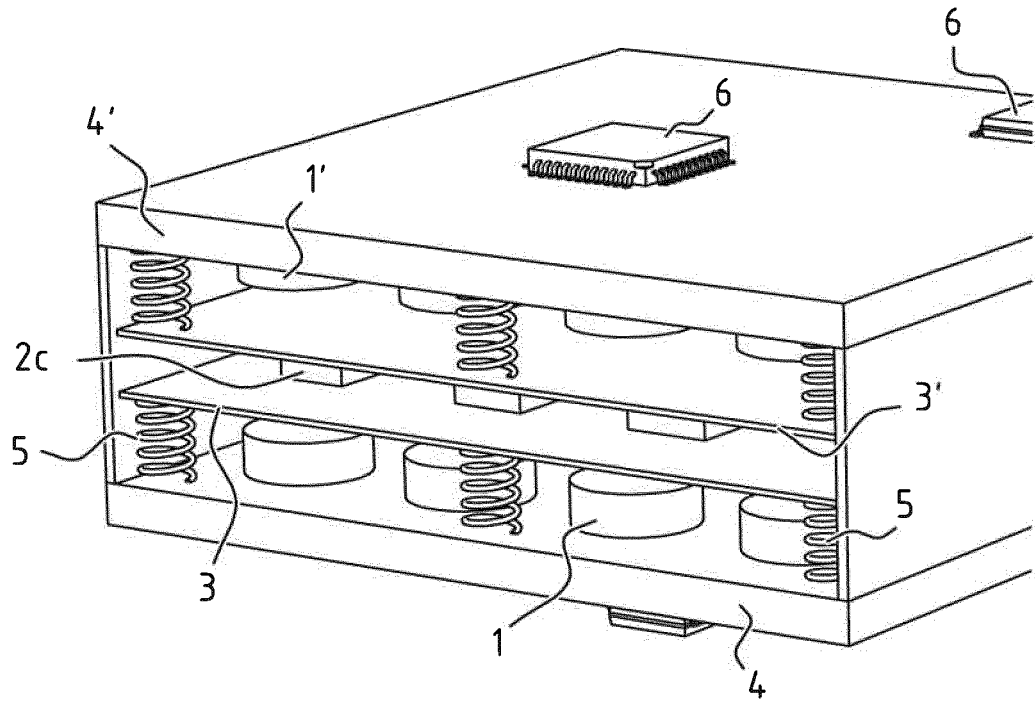

FIG. 2

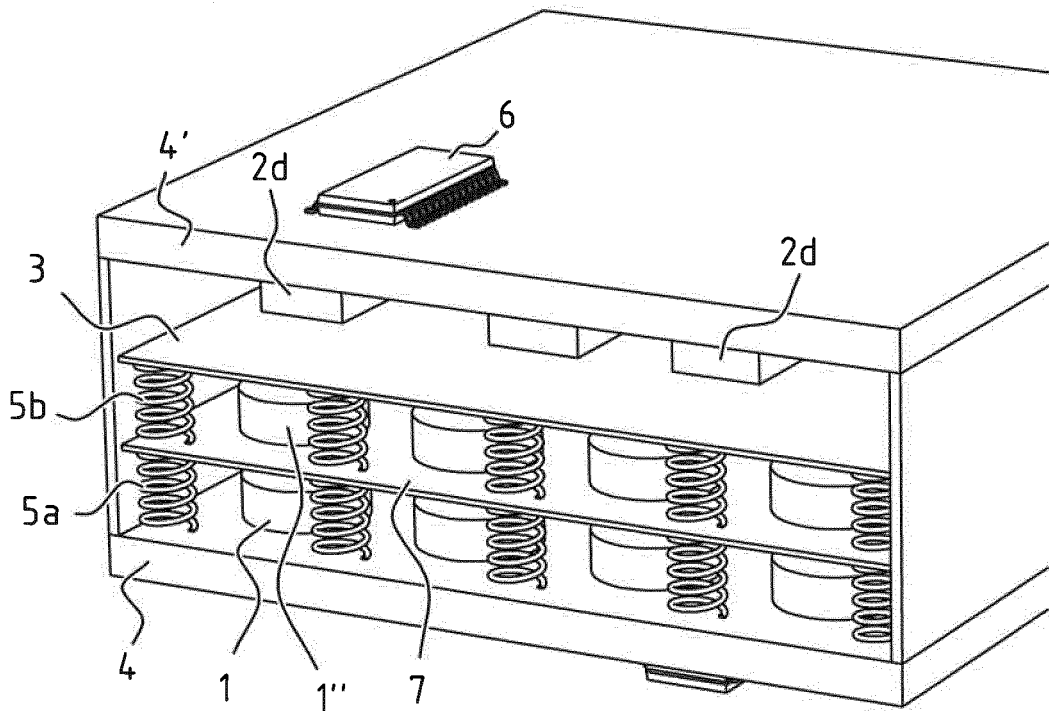

FIG. 3

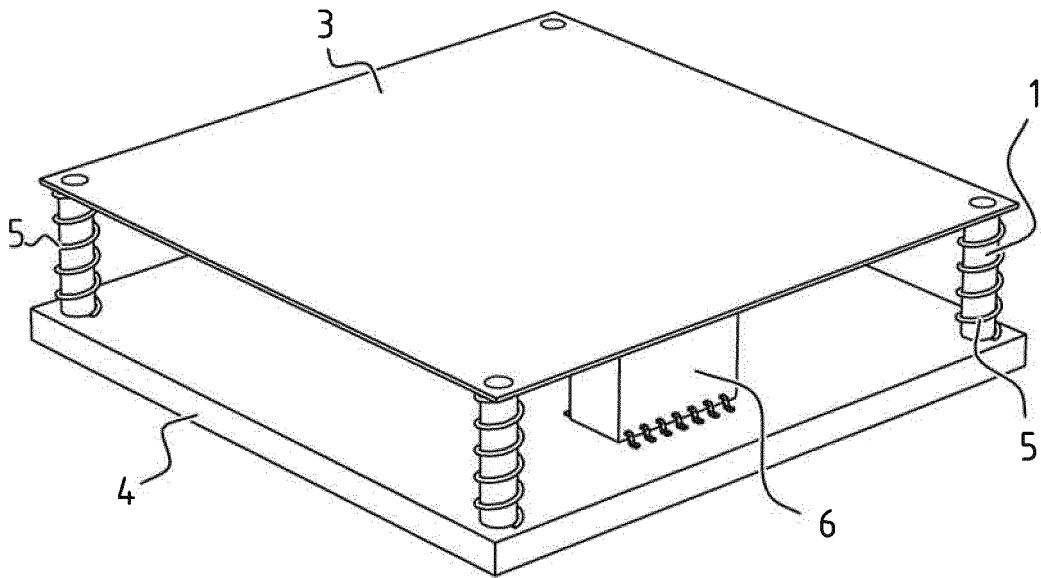

FIG. 5

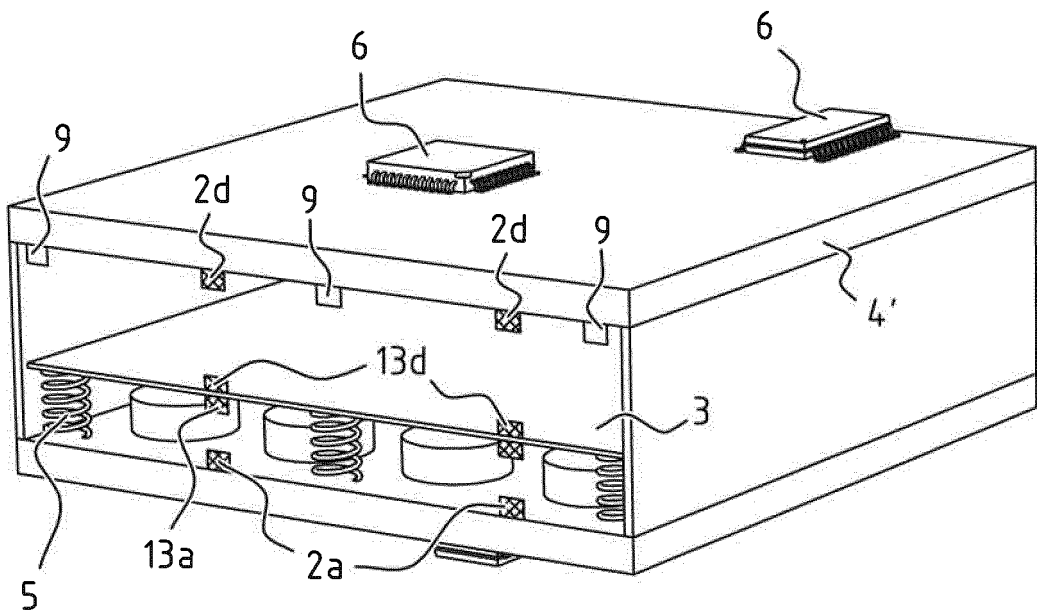

FIG. 6

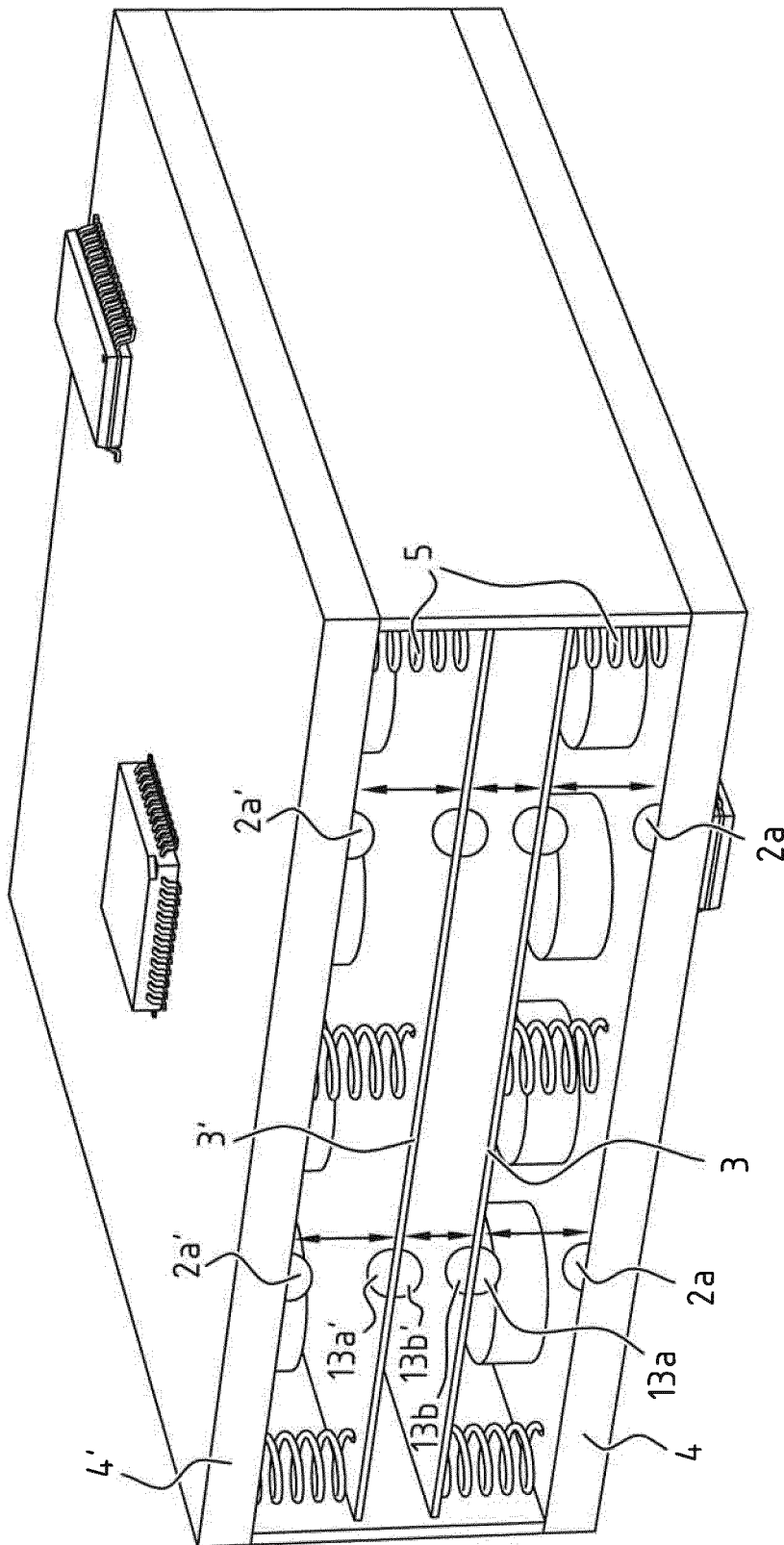

FIG. 7

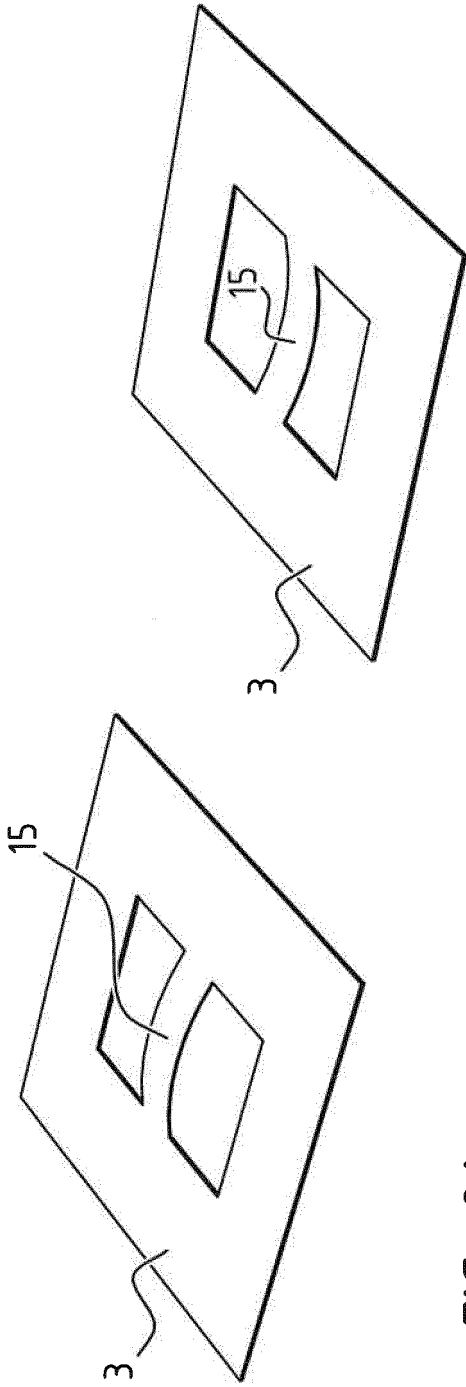

FIG. 8A

FIG. 8B

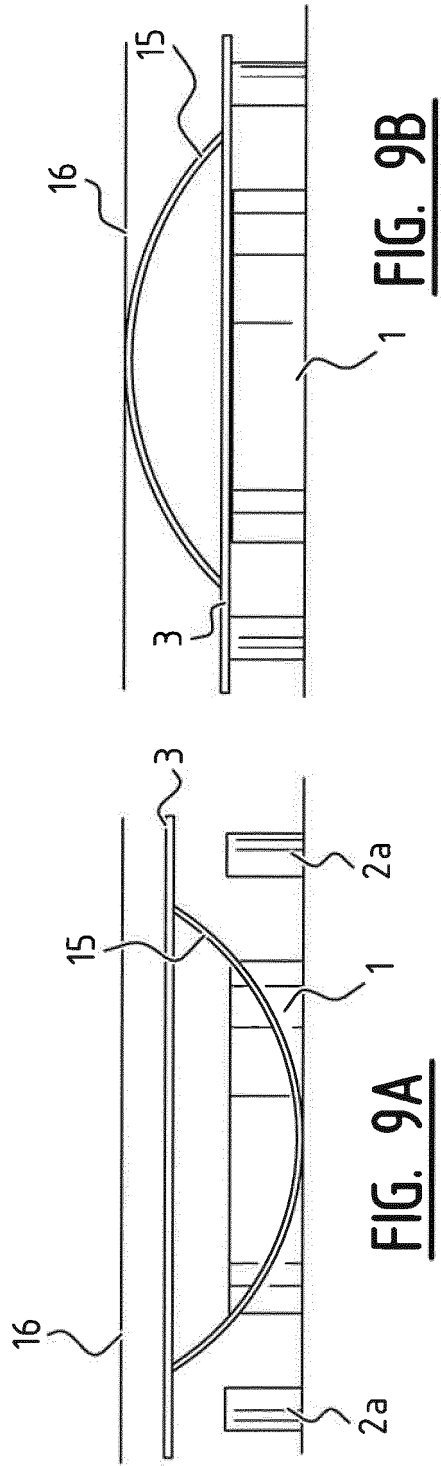

FIG. 9A

FIG. 9B

REFERENCES CITED IN THE DESCRIPTION

This list of references cited by the applicant is for the reader's convenience only. It does not form part of the European patent document. Even though great care has been taken in compiling the references, errors or omissions cannot be excluded and the EPO disclaims all liability in this regard.

Patent documents cited in the description

- US 2003174038 A [0002]