

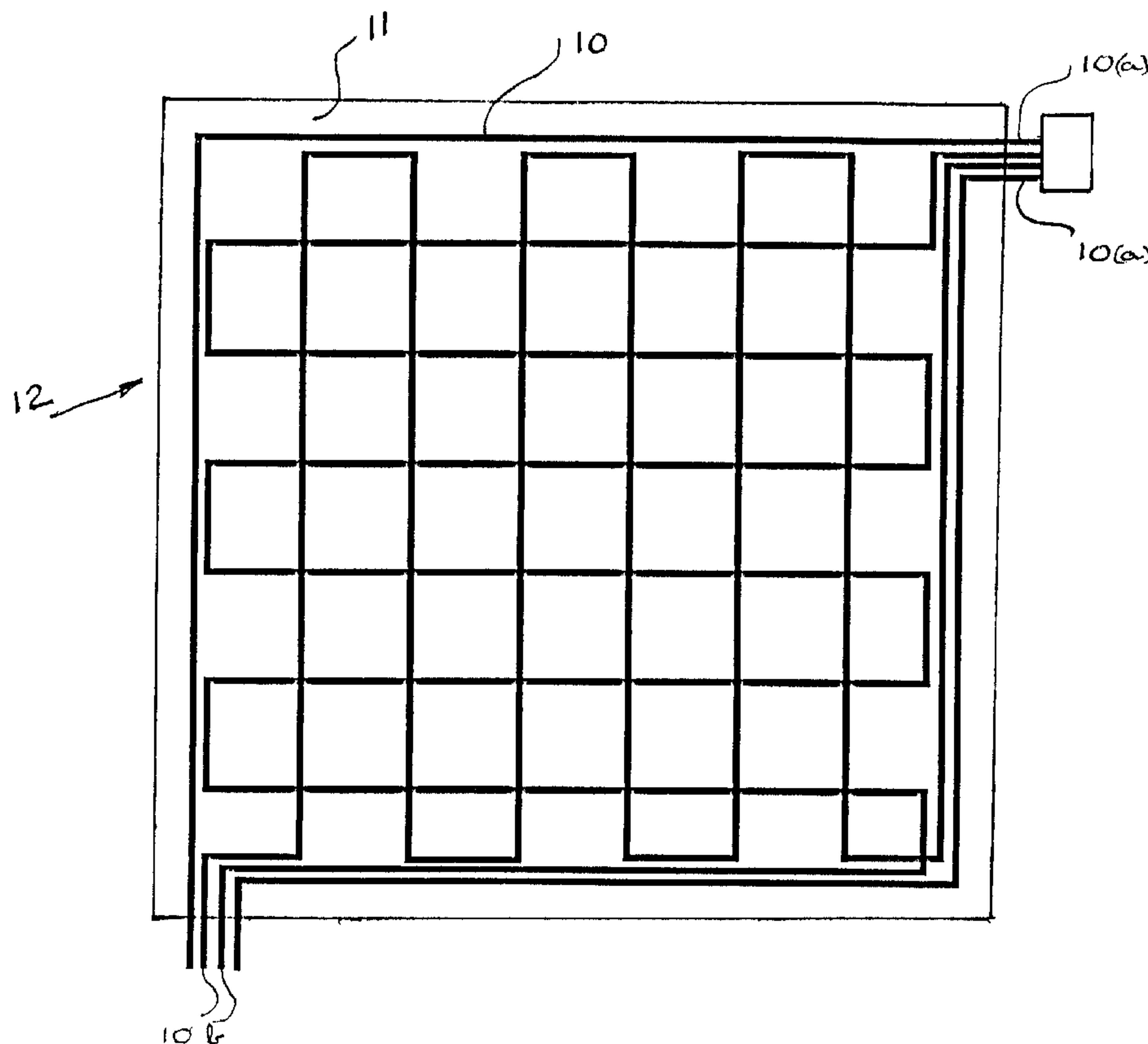

(22) Date de dépôt/Filing Date: 1996/07/26
(41) Mise à la disp. pub./Open to Public Insp.: 1997/10/25
(45) Date de délivrance/Issue Date: 2001/10/23

(51) Cl.Int.⁶/Int.Cl.⁶ H05F 3/02
(72) Inventeurs/Inventors:
White, Richard (Dick), CA;
Krossa, Ted, CA
(73) Propriétaire/Owner:
KRI-TECH POWER PRODUCTS LTD., CA
(74) Agent: MALYSZKO, THOMAS E.

(54) Titre : TAPIS DE MISE A LA TERRE
(54) Title: PORTABLE PROTECTIVE GROUNDING MAT



(57) Abrégé/Abstract:
This invention relates to a portable grounding mat, and more particularly to a mat specifically designed to protect electrical workers by providing a zone of equi-potential. The mat has a flexible base to which is attached at least one conductive element laid out in a grid pattern.

ABSTRACT

This invention relates to a portable grounding mat, and more particularly to a mat specifically designed to protect electrical workers by providing a zone of equi-potential. The mat has a flexible base to which is attached at least one conductive element laid out in a grid pattern.

The invention is directed to a portable grounding mat and more particularly to a mat specifically designed to protect electrical workers who are in contact with the ground, by providing a zone of equi-potential.

5 There has long been a problem, particularly with electrical workers, in protecting these individuals from electricution or other physical damage when they are operating with live electrical equipment and apparatus, that is grounded. Indeed, there have been many fatalities
10 over the years. One particular example, which resulted in the conception of the mat of the present invention was a case where a utility worker was killed, standing on the ground, holding a wire energized by induction.

An investigation into protection systems currently
15 available, failed to disclose any structure that could satisfy the particular requirements of this industry. An investigation into the prior art disclosed very few patents directed in any way to a solution of this problem. For example:

20 U.S. Patent 993447 issued May 30, 1911 to Hotchkiss discloses an osteopath's electric operating table, used for the purpose of electrically treating patients. By electrifying the table, and subjecting the operator to the same current flow as the patient on the table, excessive
25 currents are prevented through the body of the latter.

U.S. Patent 2,323,461 issued July 6, 1943 to Donelson discloses a spark-proof flooring system, which grounds static electricity. A sandwiched construction is utilized comprising a thin layer of conductive material, and
5 conductive studs imbedded to extend through a rubber or asphalt flooring to come into contact with the layer of conductive material. Static electricity in any object placed on the floor is grounded by contact through the studs.

10 U.S. Patent 2,457,299 issued December 28, 1948 to Lancaster et al, deals with a variation of the static electricity discharge flooring system previously discussed. In this structure, however, a non-conductive flooring backing member is provided overlaid with a strip of
15 electrically conductive plastic, the latter being connected to a current conducting grid. In use, there will always be a slow bleed of any charge on the floor through the backing and atmosphere to ground.

U.S. Patent 3,121,825 issued on February 18, 1964 to
20 Abegg et al, also discloses an electrically conductive floor covering, but specifically for use in explosive hazard areas. This system contemplates a composite floor surface material comprising a powdered electrically conductive material suspended in a plastic material.
25 Again, this floor system is designed to prevent the

accumulation of static electricity.

U.S. Patent 4,484,250 issued on November 20, 1984 to Rzepecki et al discloses a static displacement mat of composite layered construction. The top layer of vinyl having a high volume of resistivity, the sandwich is a middle
5 layer of low surface resistance on to a conductive vinyl backing. The top layer is "tacky" to collect dust particles from the air.

Finally, U.S. Patent 1,940,491 issued December 19, 1933 to Freitag, is the most relevant in respect to the subject application. This patent discloses a protective device incorporated in footwear and which includes means for
10 establishing a detachable flexible low resistance conducting connection between a ground connector and the footwear. The feet of the person are maintained at all times at the potential of the ground conductors.

None of these referenced patents, however, contemplate the provision of a zone of equi-potential, where an operator or worker may have free
15 unrestricted access.

Accordingly, in it's preferred form, the invention comprises a portable grounding mat comprising a flexible base having at least one conductive element attached to a surface of the base. The at least one element forms a continuous grid pattern on the surface of the base, substantially covering the
20 entire surface of the base. A

preferred material for the base is a vinyl/polyester fabric and the element is manufactured from high ampacity tinned copper braid.

The invention will now be described by way of example only, reference being had to the accompanying drawings in which:-

Figure 1 is a plan view of a typical mat constructed in accordance with the invention;

Figure 2 is a schematic representation of a situation where a worker is subjected to current flow, without the availability of the mat according to the present invention; and

Figure 3 is a similar schematic representation to that shown in Figure 2, of the same situation where the mat of the present invention is utilized.

Looking firstly at the mat design and construction according to Figure 1, the arrangement is simplicity itself. High ampacity tinned copper braid 10 is attached, for example, by sewing to the fabric 11, which fabric is preferably a vinyl/polyester fabric, to form a composite mat 12. In this embodiment, four continuous braids 10 are shown, two indicated as 10A, being provided around and adjacent the periphery of the mat, and the remaining two 10B are provided in a cross-over grid pattern to cover the

central area of the mat.

All braids 10 are connected to the same power source (not shown) thus ensuring that the entire mat is of one potential.

5 While it is possible to utilize only one continuous copper cable or braid 10, this is not preferred because it might not provide the safety factor that is required, since if a physical break were experienced in the cable 10, the mat might cease to be functional.

10 By utilizing two or more continuous braids 10, in an overlapping fashion, any break in one circuit would not affect the other circuits, which by virtue of the grid design would still provide a full zone of equi-potential.

Referring now to Figures 2 and 3, these are introduced to further emphasize the significance of utilizing the mat according to the invention.

15 In Figure 2, the worker 13 stands directly on the ground and in effect completes the circuit. Current flow from the source 14 flowing directly through the worker to ground. A potentially fatal situation. In Figure 3, however, the worker 13 is standing on the grounding mat 12 according to the intervention, which is connected, in circuit with the power source 14. The current flow is therefore through the mat, notwithstanding the fact that the body of the worker is at full potential.

20

In this situation, however, the worker is safe from harm.

Obviously, it will be appreciated that there is no size limitations to the inventive mat, since if larger
5 areas have to be covered, a number of separate mats can be joined together.

The grid pattern selected is of design choice only, and depends on the size and number of cables or braids utilized. It is, however, preferable that two or more
10 circuits be utilized to prevent complete circuit breakdown.

As to the size or diameter of the cables or braids 10, obviously the larger cables would be safer since it would be more difficult to damage. However, too large a diameter or size of cable, would increase the weight and hence the
15 cost of the system.

The present invention is therefore not limited to specific details and arrangements described above and many other modifications may be contemplated by those skilled in the art. The appended claims therefore must be given broad
20 interpretation commensurate with the overall scope of the invention.

WE CLAIM:

1. A portable grounding mat to protect a worker working on a power source, said mat comprising a base of flexible material having at least one conductive element attached to a surface of said base, said at least one element forming a grid pattern substantially covering the surface of said base and being in electrical communication with said power source to provide a zone of equi-potential to said worker on said base.
2. The mat of claim 1 wherein said flexible base is manufactured from a vinyl/polyester fabric.
3. The mat of claim 1 or 2 wherein said element is a high ampacity tinned copper braid.
4. The mat of claim 1, 2 or 3 wherein said element is attached to a top surface of said base.
5. The mat of claim 1, 2, 3 or 4 wherein at least one connecting means is provided adjacent an outer periphery of said base for electrically joining another of said mats to increase said zone of equi-potential.
6. A portable grounding mat to protect a worker working on a power source, said mat comprising a flexible base member and a plurality of

conductive elements forming an electrical grid across said base member, said grid being in electrical communication with said power source to provide a zone of equi-potential to said worker on said base member.

7. The mat of claim 6 wherein said flexible base member is manufactured from a vinyl/polyester fabric.

8. The mat of claim 6 or 7 wherein said conductive elements are of a high ampacity tinned copper braid.

9. The mat of claim 6, 7 or 8 wherein said conductive elements are attached to a top surface of said base member.

10. The mat of claim 6, 7, 8 or 9 wherein at least one connector is provided adjacent an edge of said base member for electrically joining another of said base members to increase said zone of equi-potential.

11. A portable grounding mat to protect a worker working on a power source, said mat comprising a base of flexible material having at least two continuous conductive elements attached to a surface of said base, at least one of said elements following a grid pattern substantially covering the surface of said base, said elements being in electrical communication with said power source to provide a zone of equi-potential to said worker on said base.

12. The mat of claim 11 wherein said flexible base is manufactured from a vinyl/polyester fabric.

13. The mat of claim 11 or 12 wherein at least one of said elements is a high ampacity tinned copper braid.

14. The mat of claim 11, 12 or 13 wherein each element is attached to a top surface of said base.

15. The mat of claim 11, 12, 13 or 14 wherein four elements are utilized, two said elements providing separate continuous peripheral circuits, and two said elements providing a central interconnected continuous grid pattern.

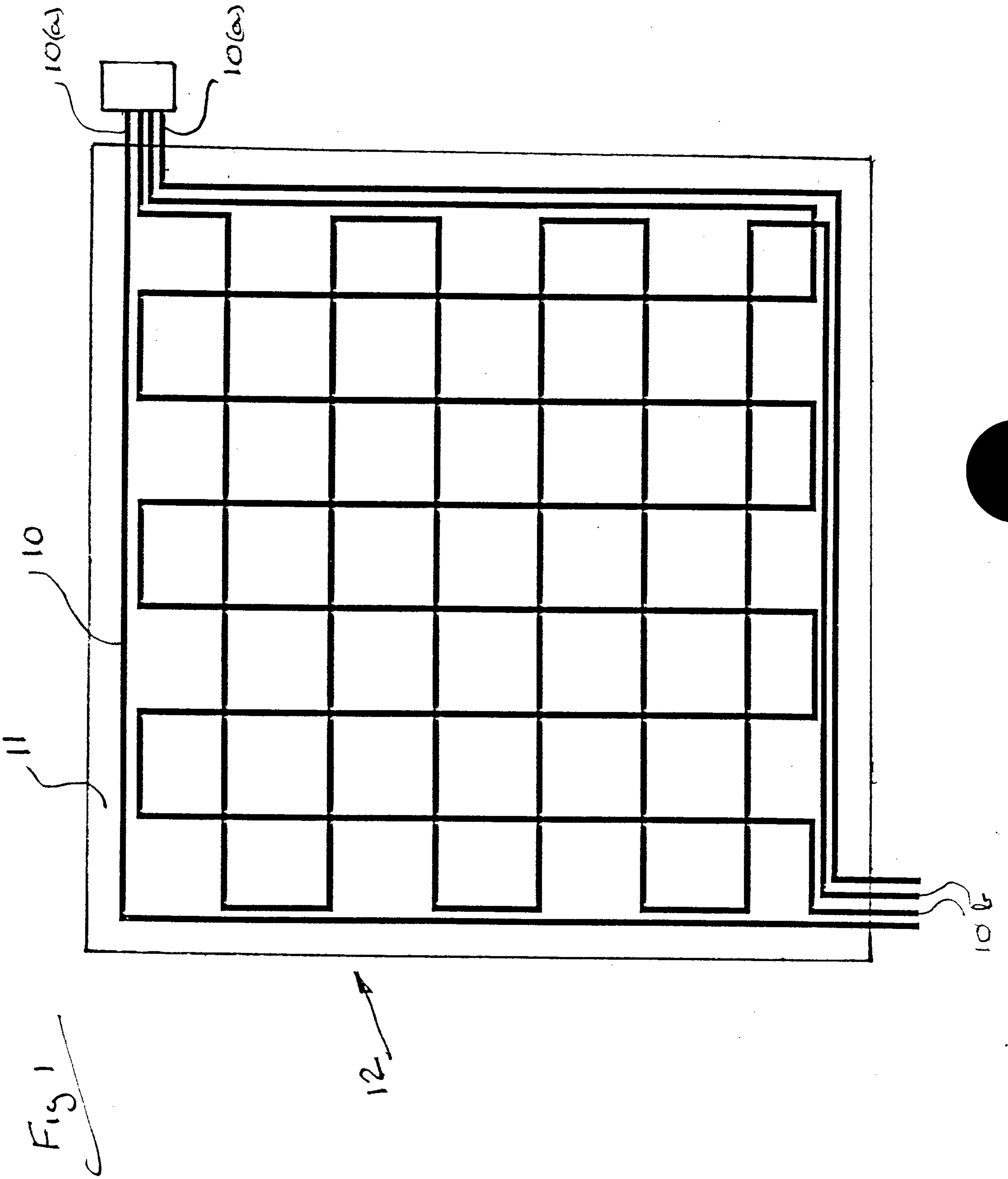

Fig 1

Fig 2

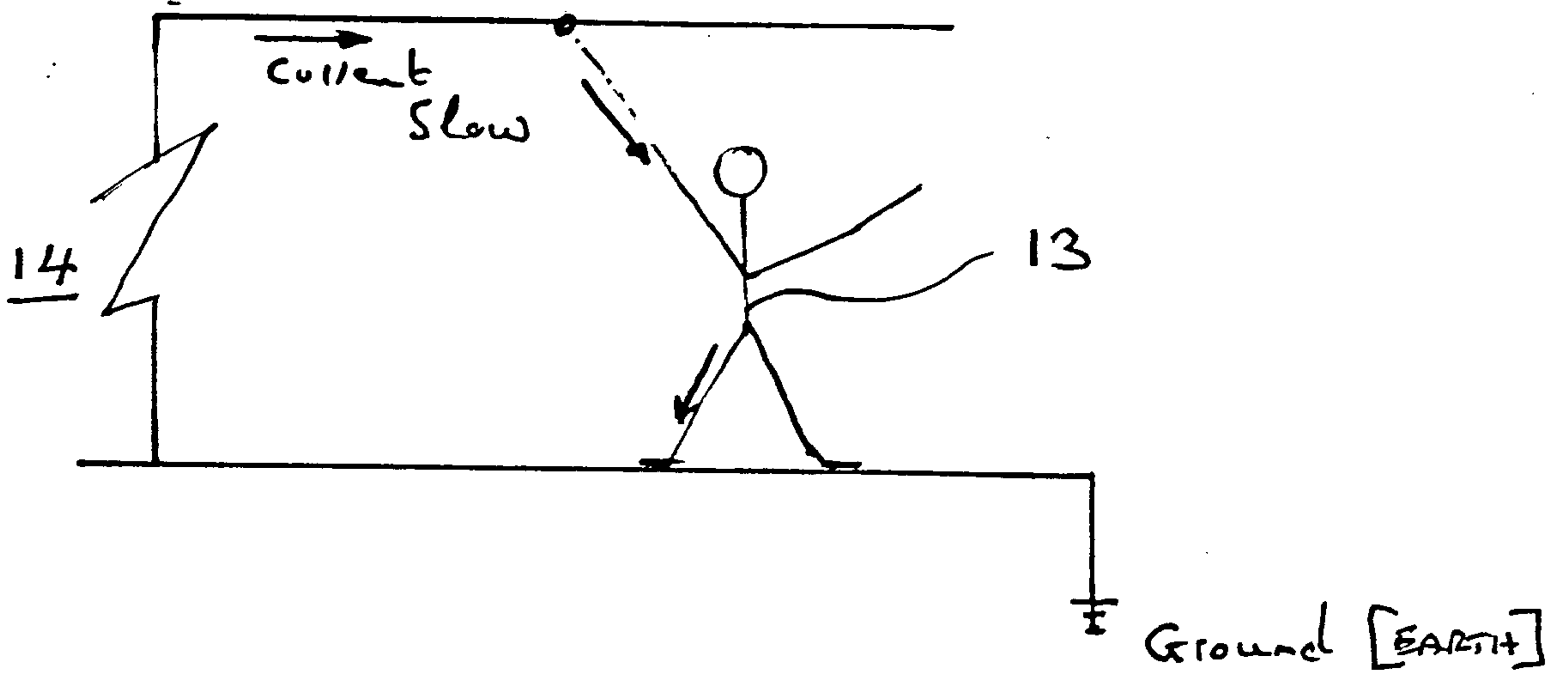

Fig 3

