



(51) International Patent Classification:

H05B 47/16 (2020.01) H05B 45/10 (2020.01)  
H05B 47/105 (2020.01) H05B 47/175 (2020.01)

(21) International Application Number:

PCT/EP2020/071822

(22) International Filing Date:

03 August 2020 (03.08.2020)

(25) Filing Language:

English

(26) Publication Language:

English

(30) Priority Data:

19190189.1 06 August 2019 (06.08.2019) EP

(71) Applicant: **SIGNIFY HOLDING B.V.** [NL/NL]; High Tech Campus 48, 5656 AE Eindhoven (NL).

(72) Inventors: **SQUILLACE, Jorge, Gabriel**; c/o High Tech Campus 7, 5656 AE Eindhoven (NL). **MAGIELSE, Remco**; c/o High Tech Campus 7, 5656 AE Eindhoven (NL). **WORM, Kevin, Thomas**; c/o High Tech Campus 7, 5656 AE Eindhoven (NL).

(74) Agent: **VAN EEUWIJK, Alexander, Henricus, Walterus** et al.; High Tech Campus 7, 5656 AE Eindhoven (NL).

(81) Designated States (unless otherwise indicated, for every kind of national protection available): AE, AG, AL, AM, AO, AT, AU, AZ, BA, BB, BG, BH, BN, BR, BW, BY, BZ, CA, CH, CL, CN, CO, CR, CU, CZ, DE, DJ, DK, DM, DO, DZ, EC, EE, EG, ES, FI, GB, GD, GE, GH, GM, GT, HN, HR, HU, ID, IL, IN, IR, IS, IT, JO, JP, KE, KG, KH, KN, KP, KR, KW, KZ, LA, LC, LK, LR, LS, LU, LY, MA, MD,

ME, MG, MK, MN, MW, MX, MY, MZ, NA, NG, NI, NO, NZ, OM, PA, PE, PG, PH, PL, PT, QA, RO, RS, RU, RW, SA, SC, SD, SE, SG, SK, SL, ST, SV, SY, TH, TJ, TM, TN, TR, TT, TZ, UA, UG, US, UZ, VC, VN, WS, ZA, ZM, ZW.

(84) Designated States (unless otherwise indicated, for every kind of regional protection available):

ARIPO (BW, GH, GM, KE, LR, LS, MW, MZ, NA, RW, SD, SL, ST, SZ, TZ, UG, ZM, ZW), Eurasian (AM, AZ, BY, KG, KZ, RU, TJ, TM), European (AL, AT, BE, BG, CH, CY, CZ, DE, DK, EE, ES, FI, FR, GB, GR, HR, HU, IE, IS, IT, LT, LU, LV, MC, MK, MT, NL, NO, PL, PT, RO, RS, SE, SI, SK, SM, TR), OAPI (BF, BJ, CF, CG, CI, CM, GA, GN, GQ, GW, KM, ML, MR, NE, SN, TD, TG).

Declarations under Rule 4.17:

— as to applicant's entitlement to apply for and be granted a patent (Rule 4.17(ii))

Published:

— with international search report (Art. 21(3))

(54) Title: A CONTROLLER FOR CONTROLLING A LIGHTING UNIT OF A LIGHTING SYSTEM AND A METHOD THEREOF

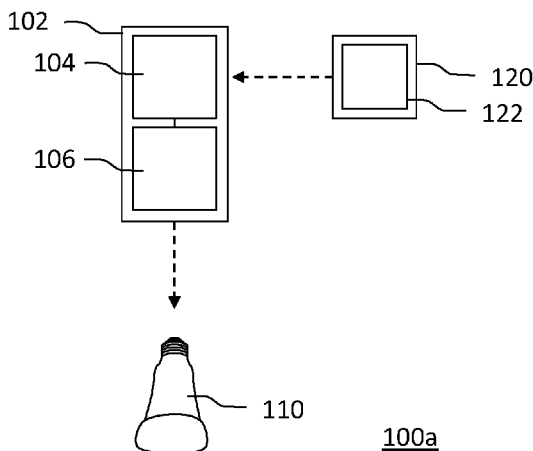

Fig. 1a

(57) Abstract: A method (400) of controlling a lighting unit (110) of a lighting system (100a, 100b) is disclosed. The lighting system (100a, 100b) comprises the lighting unit (110) and a lighting control device (120) comprising a user input element (122) for receiving a continuous user input for changing an intensity of the light output of the lighting unit (110). The method (400) comprises receiving (402) a signal indicative of the continuous user input, obtaining (404) one or more parameters, the one or more of parameters comprising at least a current light setting of the lighting unit (110), the current light setting having an intensity level between a predefined maximum intensity level and a predefined minimum intensity level, and controlling the intensity of the light output of the lighting unit (110) over time while the continuous user input is being provided, wherein the intensity of the light output is either increased or decreased based on the one or more parameters.

WO 2021/023716 A1

A controller for controlling a lighting unit of a lighting system and a method thereof

## FIELD OF THE INVENTION

The invention relates to a method of controlling a lighting unit of a lighting system, the lighting system comprising the lighting unit and a lighting control device comprising a user input element for receiving a continuous user input for changing an intensity of the light output of the lighting unit. The invention further relates to a computer program product for executing the method. The invention further relates to a controller for controlling a lighting unit of a lighting system, the lighting system comprising the lighting unit and a lighting control device comprising a user input element for receiving a continuous user input for changing an intensity of the light output of the lighting unit.

10

## BACKGROUND

Smart lighting systems enable users to control lighting units in an environment, such as the user's home. Such smart lighting systems may comprise multiple lighting units and lighting control devices (such as light switches and smartphones) connected to the lighting units. Some types of lighting control devices have a limited number of user input elements. Some light switches, for example, may have only a single button. This single button may, for example, be configured such that a user can toggle one or more lighting units on and off by pressing the button. Such a button may further be configured to receive a press-and-hold input, which may be associated with a dimming control command, and the one or more lighting units may be dimmed while the user continuously presses and holds the button.

15

20

US 9113513 B1 discloses controlling changes in light intensity by an illumination system by receiving desired dimming signals, sampling the signals, and changing the output drive signal driving the illumination system by the change increment, until the light intensity emitted by the illumination system substantially matches the desired light intensity indicated by the dimming signal. Pressing and holding a switch closed for more than a specified time period, for example 1 second, signals the microcontroller to enter a dimming mode in which it automatically dims the light-emitting element output by changing the PWM duty cycle from 100% down to 1 % over a set time period, for example 3

25

seconds. Releasing the switch and then repeating the press-and-hold action may signal the microcontroller to reverse the dimming direction and increase the light output by changing the PWM duty cycle from 1 % up to 100%. The PWM increment may automatically change based on the actual duty cycle or light level. For example, when the duty cycle is below about 2%, the PWM increment may be 1 bit, and when the duty cycle is between about 2% and about 5%, the PWM increment may be 2 bits, and when the duty cycle is above about 5%, the PWM increment may be 4 bits.

#### SUMMARY OF THE INVENTION

10 In current systems, the above-mentioned press-and-hold input either increases the intensity of the light output of the lighting unit, or it decreases the intensity of the light output. The inventors have realized that it may be desirable that such a single input element may be used for both increasing and decreasing the intensity of the light output depending on the user's needs. It is therefore an object of the present invention to provide a method and a  
15 controller that enable advanced dimming control by providing a single input.

According to a first aspect of the present invention, the object is achieved by a method of controlling a lighting unit of a lighting system, the lighting system comprising the lighting unit and a lighting control device comprising a user input element for receiving a continuous user input for changing an intensity of the light output of the lighting unit, the  
20 method comprising:

- receiving a signal indicative of the continuous user input,
- obtaining one or more parameters, the one or more of parameters comprising at least a current light setting of the lighting unit, the current light setting having a current intensity level between a predefined maximum intensity level and a predefined minimum  
25 intensity level, and
- controlling the intensity of the light output of the lighting unit over time while the continuous user input is being provided, wherein the intensity of the light output is either increased or decreased based on the one or more parameters.

The intensity of the light output of the lighting unit is controlled while the  
30 continuous user input is received. The continuous user input may, for example, be a press and hold user input provided by pressing and holding a button of a lighting control device. The light output is either increased or decreased based on the one or more parameters. The method may further comprise determining whether to increase or decrease the intensity based on the one or more parameters. The one or more parameters include at least a current light

setting of the lighting unit, the current light setting having a current intensity level between a predefined maximum intensity level and a predefined minimum intensity level. The predefined maximum intensity may, for example, be a 100% intensity, and the predefined minimum intensity may, for example, be off. Thus, if the current intensity is between the maximum and the minimum intensity of the lighting unit, the intensity of the light output of the lighting unit is either increased or decreased over time based on the current intensity. If, for example, the current intensity is high (e.g. 90% of the maximum intensity), the intensity may be decreased while the user is providing the continuous user input, and if, for example, the current intensity is low (e.g. 10% of the maximum intensity), the intensity may be increased while the user is providing the continuous user input. This is beneficial, because the such a single input element may be used for both increasing and decreasing the intensity of the light output depending on the (expected) user's needs, thereby providing advanced dimming control by providing a single input.

The one or more parameters may further comprise a current time. The current time may, for example, be a current time of day, a day in the week, month or a period/day of the year, season, etc. Thus, the determination whether to increase or decrease may be further based on the current time. A user may, for example, desire to increase the intensity early in the evening and decrease the intensity later in the evening. This is beneficial, because even more advanced dimming controls are enabled by providing a single input.

The one or more parameters may further comprise a location of the lighting unit. The location may, for example, be a geographical location, a location in a building (e.g. specific a room or space), a location in a room or a space (e.g. at the ceiling, on the floor, in a corner, in the center of a room, etc.), a location relative to another device or object (e.g. a tv, a table, etc.), etc. Thus, the determination whether to increase or decrease the intensity may be further based on the location of the lighting unit. A user may, for example, desire to increase the intensity of lighting units located in the living room, and decrease the intensity of lighting units in the bedroom. This is beneficial, because even more advanced dimming controls are enabled by providing a single input.

The method may further comprise: ceasing increasing or decreasing the intensity when the continuous user input is no longer being provided. Thus, when the user no longer provides the continuous input, the increase or decrease of the intensity is stopped, and the intensity is set to its current intensity level. This enables a user to select the desired intensity, simply by no longer providing the continuous user input.

The method may further comprise: when the intensity reaches the predefined maximum intensity level while the continuous user input is being provided, decreasing the intensity over time while the continuous user input is being provided, and when the intensity reaches the predefined minimum intensity level while the continuous user input is being provided, increasing the intensity over time while the continuous user input is being provided. For example, when the intensity is being increased, and the predefined maximum intensity is reached, the intensity may be decreased (as long as the continuous user input is provided). This enables a user to cycle through the dimming levels by providing the continuous user input. This is beneficial, because even more advanced dimming controls are enabled by providing a single input.

The method may further comprise, when the continuous user input is no longer received:

- receiving a second signal indicative of a second continuous user input received via the same user input element, and
- if the intensity was being decreased while the continuous user input was being provided, increasing the intensity over time while the second continuous user input is being provided, and
- if the intensity was being increased while the continuous user input was being provided, decreasing the intensity over time while the second continuous user input is being provided. This enables a user to stop providing the continuous user input (e.g. by releasing the button), and subsequently providing a second continuous user input (e.g. by pressing and holding the button again), whereupon the intensity change is reversed (from increase to decrease, or vice versa). This enables even more advanced dimming control via a single input element.

The predefined minimum and maximum intensity levels may be minimum and maximum intensity levels of the lighting unit. The predefined maximum intensity may, for example, be a 100% intensity, and the predefined minimum intensity may, for example, be off.

The predefined minimum and maximum intensity levels may be based on a light intensity profile. The light intensity profile may, for example, be a dimming curve defining a plurality of dimming values, according to which the lighting unit may be controlled.

The method further may further comprise:

- entering a learning mode, to learn, over a period of time, associations between user inputs indicative of changes of the intensity of the light output of one or more lighting units and one or more current parameters,
- switching to a control mode, and
- 5 - executing the steps of any one of the above-mentioned methods, wherein the method further comprises: determining whether to increase or decrease the intensity of the light output based on the learned associations. In other words, user preferences related to parameters (e.g. current light settings, time of day, location of the lighting units, etc.) may be monitored during a monitoring period. These user preferences may then be used to determine  
10 whether to increase or decrease the intensity of the light output. This is beneficial, because the dimming control is tailored to a specific user's preferences.

The lighting control device may be a light switch, and the continuous user input may be received by actuating and holding a button of the light switch. The button may, for example, be a press or touch button. In another example, the lighting control device may  
15 be a personal device, such as a smartphone, and the continuous user input may be received by actuating and holding a touch sensitive display of the personal device. In another example, the lighting control device may be an augmented reality device, and the continuous user input may be a gaze of a user towards a certain lamp, detected by for example a camera comprised in the augmented reality device. In another example, the lighting control device may  
20 comprise an audio sensor, and the continuous user input may be a continuous sound created by the user, detected by the audio sensor.

According to a second aspect of the present invention, the object is achieved by a computer program product for a computing device, the computer program product comprising computer program code to perform any of the above-mentioned methods when  
25 the computer program product is run on a processing unit of the computing device.

According to a third aspect of the present invention, the object is achieved by a controller for controlling a lighting unit of a lighting system, the lighting system comprising the lighting unit and a lighting control device comprising a user input element for receiving a continuous user input for changing an intensity of the light output of the lighting unit, the  
30 controller comprising:

- a communication unit for receiving a signal indicative of the continuous user input,

- a processor configured to control the intensity of the light output of the lighting unit, wherein the processor is further configured to:

- obtain one or more parameters, the one or more of parameters comprising at least a current light setting of the lighting unit, the current light setting having an intensity level between a maximum intensity level and a minimum intensity level of the lighting unit, and

5 - controlling the intensity of the light output of the lighting unit over time while the continuous user input is being provided, wherein the intensity of the light output is either increased or decreased based on the one or more parameters.

It should be understood that the computer program product and the controller may have similar and/or identical embodiments and advantages as the above-mentioned methods.

10

#### BRIEF DESCRIPTION OF THE DRAWINGS

The above, as well as additional objects, features and advantages of the disclosed systems, devices and methods will be better understood through the following illustrative and non-limiting detailed description of embodiments of devices and methods, with reference to the appended drawings, in which:

15

Fig. 1a shows schematically an embodiment of a lighting system comprising a lighting unit, a lighting control device and a controller for controlling the lighting device;

Fig. 1b shows schematically an embodiment of a lighting system comprising a lighting unit, and a lighting control device comprising a controller for controlling the lighting device;

20

Fig. 2 shows schematically an example of a lighting control device;

Fig. 3 shows schematically a dimming curve; and

Fig. 4 shows schematically a method of controlling a lighting unit of a lighting system.

25

All the figures are schematic, not necessarily to scale, and generally only show parts which are necessary in order to elucidate the invention, wherein other parts may be omitted or merely suggested.

#### DETAILED DESCRIPTION OF EMBODIMENTS

30

Figs. 1a and 1b show exemplary systems 100a, 100b comprising a controller 102 for controlling a lighting unit 110 based on user inputs received from a user input element 122 of a lighting control device 120. The user input may be a continuous user input for changing an intensity of the light output of the lighting unit 110. In the example of Fig. 1a, the lighting control device 120 and the controller 102 are different devices. The controller

102 may, for example, be comprised in a smartphone, in a bridge device, in a central home/lighting control system, in the lighting unit 110, on a remote server (e.g. in the cloud), etc. Alternatively, as illustrated in Fig. 1b, the controller 102 may be comprised in the lighting control device 120. The controller 102 comprises a communication unit 104  
5 configured to receive signals indicative of user inputs from the lighting control device 120, and a processor 106 (e.g. a microcontroller, circuitry, a microchip, etc.).

The processor 106 is configured to obtain one or more parameters. These parameters may be contextual parameters that provide information about the context (e.g. the environment) wherein the lighting unit 110 is located. The one or more parameters may be  
10 received from external devices (e.g. via the communication unit 104), from one or more sensors (which may be located remotely or comprised in the controller 102), etc. The one or more of parameters may comprise a current light setting of the lighting unit 120, the current light setting being the light setting of the lighting unit 110 at the moment the user input has been received (e.g. at the moment the user actuates a button). The current light setting may be  
15 determined in various ways, for example by transmitting a status request message to the lighting unit 110, by transmitting a status request message to a central control system (e.g. a hub, a bridge) connected to the lighting unit 110, by accessing a memory storing information about a last-sent command that has been transmitted to the lighting unit 110, etc. The current light setting may have an intensity level between a predefined maximum intensity level and a  
20 predefined minimum intensity level. The current light setting may, for example, have an intensity level between 0% and 100% (e.g. 40%). The processor 106 is further configured to control the intensity of the light output of one or more lighting units 110 over time while the continuous user input is being provided. The processor 106 may determine whether to increase or decrease the intensity of the light output of the one or more lighting units 110  
25 based on the one or more (contextual) parameters. When, for example, a user actuates and holds the user input element 122 of the lighting control device 120, the processor 106 may for example determine that the current intensity of the light output of the lighting unit 110 is 20%, and receive one or more signals from the lighting control device 120 indicative of the continuous user input. Based on the intensity level of 20%, the processor 106 may, for  
30 example, determine to increase the intensity of the light output lighting unit 110 while the user is providing the continuous user input. When the user stops providing the continuous input, the controller 102 may cease increasing the intensity and set the intensity to the last (current) intensity level.

The processor 106 may be further configured to determine whether to increase or decrease the intensity of the light output of the lighting unit 110 based on one or more light current light intensities of one or more further lighting units. If, for example, one or more further lighting units have a current intensity different (e.g. higher) from the current intensity of the lighting unit 110 that is to be controlled, the processor 106 may be configured to determine to control the intensity over time while the continuous user input is being received such that the intensity level of the lighting unit 110 increases or decreases towards the current intensities of the one or more further lighting units. In another example, the processor may be configured to control a group of lighting units comprising the lighting unit 110 and one or more further lighting units, and the processor 106 may determine to increase/decrease the intensity of the light output of the individual lighting units of the group of lighting units based on the current intensities of the lighting units of the group of lighting units. The processor 106 may, for example, determine to increase the intensity of all lighting units of the group when their average intensity is low. The processor 106 may, for example, determine to increase the intensity of some lighting units of the group that have a lower intensity than an average intensity of the group, and decrease the intensity of some lighting units of the group that have a higher intensity than the average intensity of the group, in order to reach a common e.g. (average or target) intensity level. If the group of lighting units have the same current intensity, the processor 106 may determine to increase or decrease the intensity of the group synchronously based on their current intensity.

The lighting control device 120 may be any type of lighting control device (e.g. a light switch, a smartphone, smart glasses, a voice-controlled home assistant, etc.) comprising a user input element 122 configured to receive continuous user inputs indicative of a dimming command. The lighting control device 120 may be a light switch, and the continuous user input may be received by actuating and holding a button of the light switch. The button may, for example, be a press or touch button. Such a light switch 220a comprising a button 222a has been illustrated in Fig. 2. In another example, the lighting control device 120 may be a personal device, such as a smartphone, and the continuous user input may be received by actuating and holding a touch sensitive display 122 of the personal device. In another example, the lighting control device 120 may be an augmented reality (AR) device, and the continuous user input may be a gaze of a user towards a certain lamp, detected by for example a camera 112 comprised in the AR device. In another example, the lighting control device 120 may comprise an audio sensor 122, and the continuous user input may be a continuous sound created by the user, detected by the audio sensor.

The controller 102 comprises a communication unit 104 configured to receive a signal indicative of the continuous user input. In the example of Fig. 1a, wherein the lighting control device 120 and the controller 102 are comprised in separate devices, the communication unit 104 may be a receiver configured to receive (wireless) signals from the lighting control device 120. The receiver may be coupled to the processor 106 and communicate the received signals to the processor 106. In the example of Fig. 1b, wherein the controller 102 is comprised in the lighting control device 120, the communication unit 104 may for example be an input module of the processor 106 located between the user input element 122 and the processor 106.

In the example of Fig. 1a, wherein the lighting control device 120 and the controller 102 are comprised in separate devices, the communication unit 104 may comprise a transmitter for transmitting control commands to the lighting unit 110 to control the intensity of the light output of the lighting unit 110. In the example of Fig. 1b, wherein the controller 102 is comprised in the lighting control device 120, the processor 106 may (directly) control the intensity of the light output of the lighting unit 110.

The lighting unit 110 is configured to receive (wireless) signals (e.g. lighting control signals) from the controller 102. The (wireless) signals may be received directly from the controller 102 or via an intermediary device such as a bridge, a hub, a router, or another network device. The controller 102 may comprise a communication unit configured to communicate lighting control signals via any wired or wireless communication protocol (e.g. Ethernet, DALI, Bluetooth, Wi-Fi, Li-Fi, Thread, ZigBee, etc.). The lighting unit 110 may be an LED light bulb, an LED strip, a TLED, a light tile, etc.). The lighting unit 110 may comprise a control unit, such as a microcontroller (not shown), for controlling the light output generated by the lighting units based on received lighting control commands. A lighting control signal may comprise lighting control instructions for controlling the light output, such as the color, intensity, saturation, beam size, beam shape, etc. according to which the lighting unit 110 is controlled.

The processor 106 may be configured to access a memory configured to store a lookup table comprising associations between (current) intensity levels and an indication to increase or decrease the intensity. Table 1 illustrates an example of such a table. If, for example, the intensity level is 30% at the moment the user starts pressing the button, the processor 106 may determine to increase the intensity (e.g. until the user no longer provides the input (e.g. when the level is 90%, or all the way until 100%).

<i>Current intensity</i>	<i>Intensity change</i>
0-25%	Increase intensity
25-50%	Increase intensity
50-75%	Decrease intensity
75-100%	Decrease intensity

Table 1

The processor 106 may be further configured to determine/obtain a current time, and the current time may be a parameter used by the processor 106 to determine whether to increase or decrease the intensity of the light output of the lighting unit 110. The controller 102 may comprise an internal clock for providing the time to the processor 106. Alternatively, the processor 106 may receive the current time from an external clock (e.g. via a network via the communication unit 104). The current time may, for example, be a current time of day, a current day in the week, month or a current period/day of the year and/or a current season. Table 2 illustrates an example wherein both the current intensity and the current time are parameters used to determine whether to increase or decrease the intensity. If, for example, the intensity level is 30% and the time is 20:00 at the moment the user starts pressing the button, the processor 106 may determine to increase the intensity (e.g. until the user no longer provides the input (e.g. when the level is 90%), or all the way until 100%), but if the user would provide the same input at the same intensity level (30%) at a later time (e.g. 22:00), the processor 106 may determine to decrease the intensity (e.g. until the user no longer provides the input (e.g. when the level is 10%), or all the way until 0%).

<i>Current intensity</i>	<i>Current time</i>	<i>Intensity change</i>
0-25%	18:00-21:00	Increase intensity
0-25%	21:00-23:00	Decrease intensity
25-50%	18:00-21:00	Increase intensity
25-50%	21:00-23:00	Decrease intensity
50-75%	18:00-21:00	Increase intensity
50-75%	21:00-23:00	Decrease intensity
75-100%	18:00-21:00	Decrease intensity
75-100%	21:00-23:00	Decrease intensity

Table 2

The processor 106 may be further configured to determine/obtain information about the location of the lighting unit 110, and the location may be a parameter used by the

processor 106 to determine whether to increase or decrease the intensity of the light output of the lighting unit 110. The location of the lighting unit 110 may be obtained by the processor by accessing a memory storing information about the location of the lighting unit 110, by receiving information (via the communication unit 104) about the location of the lighting unit 110 from an (indoor) positioning system, by receiving information (via the communication unit 104) about the location of the lighting unit 110 from a central lighting control system (e.g. a bridge), etc. The location may, for example, be a geographical location, a location in a building (e.g. specific a room or space), a location in a room or a space (e.g. at the ceiling, on the floor, in a corner, in the center of a room, etc.), a location relative to another device or object (e.g. a tv, a table, etc.), etc. Table 2 illustrates an example wherein both the current intensity and the location are parameters used to determine whether to increase or decrease the intensity. If, for example, the intensity level is 30% at the moment the user starts pressing the button and the lighting unit 110 is located in the living room, the processor 106 may determine to increase the intensity (e.g. until the user no longer provides the input (e.g. when the level is 90%), or all the way until 100%), but if the user would provide the same input at the same intensity level (30%) for a lighting unit located in the bedroom, the processor 106 may determine to decrease the intensity (e.g. until the user no longer provides the input (e.g. when the level is 10%, or all the way until 0%).

<i>Current intensity</i>	<i>Location</i>	<i>Intensity change</i>
0-25%	Living room	Increase intensity
0-25%	Bedroom	Decrease intensity
25-50%	Living room	Increase intensity
25-50%	Bedroom	Decrease intensity
50-75%	Living room	Increase intensity
50-75%	Bedroom	Decrease intensity
75-100%	Living room	Decrease intensity
75-100%	Bedroom	Decrease intensity

*Table 3*

In the examples of Tables 2 and 3, two parameters are mentioned. It should be understood that the processor 106 may be configured to take more than two parameters (e.g. the current intensity, the location and the current time) into account to determine whether to increase or decrease the intensity of the light output of the lighting unit 110. Examples of other parameters include but are not limited to the current weather information (e.g. uncloudy vs cloudy, which information may be obtained from a weather application), temperature

information (which may be obtained from a temperature sensor), occupancy information (e.g. a single person vs multiple people, which may be detected by a camera or other presence sensor), information indicative of an activity of the user operating the lighting control device 120 (which information may for example be detected by a camera, a wearable device, etc.),  
5 current light intensities of one or more further lighting units, etc. It should be understood that the above-mentioned lookup tables are mere examples for the processor 106 to determine whether to increase or decrease the intensity, and that the skilled person is able to design alternatives (algorithms) for determining whether to increase or decrease the intensity based on the one or more parameters, without departing from the scope of the appended claims.

10 The processor 106 may be further configured to cease increasing or decreasing the intensity when the continuous user input is no longer being provided. In other words, when the user stops providing the continuous input (e.g. by releasing a button 222a of a light switch 220a) at a certain intensity (e.g. at 40%), the processor 106 may set the intensity of the light output of the lighting unit 110 to that intensity (e.g. 40%).

15 The processor 106 may be further configured to, when the intensity reaches the predefined maximum intensity level while the continuous user input is being provided, to start decreasing the intensity over time while the continuous user input is being provided. If, for example, the intensity is being increased, and the predefined maximum intensity is reached, the processor 106 may start decreasing the intensity. This enables a user to cycle  
20 through the dimming levels by providing the continuous user input.

The processor 106 may be further configured to, when the intensity reaches the predefined minimum intensity level while the continuous user input is being provided, start increasing the intensity over time while the continuous user input is being provided. If, for example, the intensity is being decreased, and the predefined minimum intensity is  
25 reached, the processor 106 may start increasing the intensity. This enables a user to cycle through the dimming levels by providing the continuous user input.

The increase or decrease of the intensity of the light output over time may be linear, exponential, etc. The increase or decrease of the intensity of the light output over time may be based on a light intensity profile. The light intensity profile may, for example, be a  
30 dimming curve defining a plurality of dimming values, according to which the lighting unit may be controlled. Fig. 3 illustrates an example of a light intensity profile. A user may, for example, provide the continuous user input  $u/I$  when the current intensity  $i$  is approximately 10%. Based thereon, the processor 106 may determine to start increasing the intensity over time while the user is providing the continuous user input until the peak (the maximum intensity)

of the curve has been reached. The processor 106 may then determine to reduce the intensity while the user is providing the continuous user input. In another example, a user may, for example, provide the continuous user input  $u_2$  when the current intensity  $i$  is approximately 90%. Based thereon, the processor 106 may determine to start decreasing the intensity over  
5 time while the user is providing the continuous user input until the bottom of the curve (the minimum intensity) has been reached. The processor 106 may then determine to increase the intensity while the user is providing the continuous user input. In the example of Fig. 3 the curve is symmetrical and repetitive. The curve, however, may be asymmetrical and comprise different maxima, minima, and slopes according to which the lighting unit 110 may be  
10 controlled over time while the user is providing the continuous user input.

A user may stop providing the continuous user input and provide a subsequent second continuous user input within a predefined time period after the (first) continuous user input. The processor 106 may be configured to receive a second signal indicative of the second continuous user input received via the same user input element. The processor 106  
15 may be further configured to increase the intensity, if the intensity was being decreased while the continuous user input was being provided, over time while the second continuous user input is being provided. The processor 106 may be further configured to decrease the intensity, if the intensity was being increased while the continuous user input was being provided, over time while the second continuous user input is being provided. For instance,  
20 referring to Fig. 3, the processor 106 may control the intensity of the light output of the lighting unit 110 according to the curve while the continuous user input is being received, and control the intensity of the light output of the lighting unit 110 in the opposite direction of the curve while the second continuous user input is being received.

The predefined minimum and maximum intensity levels may be minimum and  
25 maximum intensity levels that can be provided by the lighting unit 110. The predefined maximum intensity may, for example, be a 100% intensity, and the predefined minimum intensity may, for example, be off. In another example, the predefined minimum and maximum intensity levels may be based on a light intensity profile (e.g. the curve shown in Fig. 3). The light intensity profile may, for example, be a dimming curve defining a plurality  
30 of dimming values, according to which the lighting unit may be controlled. In another example, the predefined minimum and maximum intensity levels may be minimum and maximum intensity levels of an active light scene. The light scene may be a set of light settings for a plurality of lighting units, wherein the plurality of lighting units are controlled

according to a set of rules (e.g. a set of colors, a minimum and maximum intensity, etc.).  
these rules may indicate the minimum and maximum intensity levels.

The processor 106 may be further configured to enter a learning mode to learn,  
over a period of time, associations between user inputs indicative of changes of the intensity  
5 of the light output of one or more lighting units and one or more current parameters. In other  
words, user preferences related to parameters (e.g. current light settings, time of day, location  
of the lighting units, etc.) and lighting control provided by users related to increasing or  
decreasing the intensity may be monitored during a monitoring/learning period. The  
processor 106 may use machine learning algorithms to learn these user preferences. Such  
10 algorithms are known in the art and will therefore not be discussed in detail. The user  
preferences may then be used to determine whether to increase or decrease the intensity of  
the light output when the processor 106 has been set to the control mode.

Fig. 4 illustrates a method of controlling a lighting unit 110 of a lighting  
system 100a, 100b, the lighting system comprising the lighting unit 110 and a lighting control  
15 device 120 comprising a user input element 122 for receiving a continuous user input for  
changing an intensity of the light output of the lighting unit 110, the method 400 comprising:  
receiving 402 a signal indicative of the continuous user input, obtaining 404 one or more  
parameters, the one or more of parameters comprising at least a current light setting of the  
lighting unit, the current light setting having an intensity level between a predefined  
20 maximum intensity level and a predefined minimum intensity level, and control 406 the  
intensity of the light output of the lighting unit over time while the continuous user input is  
being provided, wherein the intensity of the light output is either increased or decreased over  
time based on the one or more parameters.

The method 400 may be executed by computer program code of a computer  
25 program product when the computer program product is run on a processing unit of a  
computing device, such as the processor 106 of the controller 102.

It should be noted that the above-mentioned embodiments illustrate rather than  
limit the invention, and that those skilled in the art will be able to design many alternative  
embodiments without departing from the scope of the appended claims.

30 In the claims, any reference signs placed between parentheses shall not be  
construed as limiting the claim. Use of the verb "comprise" and its conjugations does not  
exclude the presence of elements or steps other than those stated in a claim. The article "a" or  
"an" preceding an element does not exclude the presence of a plurality of such elements. The  
invention may be implemented by means of hardware comprising several distinct elements,

and by means of a suitably programmed computer or processing unit. In the device claim enumerating several means, several of these means may be embodied by one and the same item of hardware. The mere fact that certain measures are recited in mutually different dependent claims does not indicate that a combination of these measures cannot be used to advantage.

Aspects of the invention may be implemented in a computer program product, which may be a collection of computer program instructions stored on a computer readable storage device which may be executed by a computer. The instructions of the present invention may be in any interpretable or executable code mechanism, including but not limited to scripts, interpretable programs, dynamic link libraries (DLLs) or Java classes. The instructions can be provided as complete executable programs, partial executable programs, as modifications to existing programs (e.g. updates) or extensions for existing programs (e.g. plugins). Moreover, parts of the processing of the present invention may be distributed over multiple computers or processors or even the 'cloud'.

Storage media suitable for storing computer program instructions include all forms of nonvolatile memory, including but not limited to EPROM, EEPROM and flash memory devices, magnetic disks such as the internal and external hard disk drives, removable disks and CD-ROM disks. The computer program product may be distributed on such a storage medium, or may be offered for download through HTTP, FTP, email or through a server connected to a network such as the Internet.

## CLAIMS:

1. A method (400) of controlling a lighting unit (110) of a lighting system (100a, 100b), the lighting system (100a, 100b) comprising the lighting unit (110) and a lighting control device (120) comprising a user input element (122) for receiving a continuous user input for changing an intensity of the light output of the lighting unit (110), the method (400)

5 comprising:

- receiving (402) a signal indicative of the continuous user input,
- obtaining (404) parameters, the parameters comprising at least a current light setting of the lighting unit (110) and a current time, the current light setting having an intensity level between a predefined maximum intensity level and a predefined minimum

10 intensity level, and

- controlling the intensity of the light output of the lighting unit (110) over time while the continuous user input is being provided, wherein the intensity of the light output is either increased or decreased based on the parameters comprising at least the current light setting of the lighting unit (110) and the current time.

15

2. The method (400) of any preceding claim, wherein the parameters further comprise a location of the lighting unit (110).

3. The method (400) of any preceding claim, wherein the parameters further

20 comprise one or more light current light intensities of one or more further lighting units.

4. The method (400) of any preceding claim, further comprising ceasing increasing or decreasing the intensity when the continuous user input is no longer being provided.

25

5. The method (400) of any preceding claim, wherein the method (400) comprises:

- when the intensity reaches the predefined maximum intensity level while the continuous user input is being provided, decreasing the intensity over time while the continuous user input is being provided, and

5 - when the intensity reaches the predefined minimum intensity level while the continuous user input is being provided, increasing the intensity over time while the continuous user input is being provided.

6. The method (400) of any preceding claim, further comprising, when the continuous user input is no longer received:

10 - receiving a second signal indicative of a second continuous user input received via the same user input element (122), and

- if the intensity was being decreased while the continuous user input was being provided, increasing the intensity over time while the second continuous user input is being provided, and

15 - if the intensity was being increased while the continuous user input was being provided, decreasing the intensity over time while the second continuous user input is being provided.

7. The method (400) of any preceding claim, wherein the predefined minimum and maximum intensity levels are minimum and maximum intensity levels of the lighting unit (110).

8. The method (400) of any preceding claim, wherein the predefined minimum and maximum intensity levels are based on a light intensity profile.

25

9. The method (400) of any preceding claim, wherein the method (400) further comprises:

- entering a learning mode, to learn, over a period of time, associations between user inputs indicative of changes of the intensity of the light output of one or more lighting units and one or more current parameters,

30

- switching to a control mode, and

- executing the steps of any one of the above-mentioned methods (400), wherein the method (400) further comprises: determining whether to increase or decrease the intensity of the light output based on the learned associations.

10. The method (400) of any preceding claim, wherein the lighting control device (120) is a light switch, and the continuous user input is received by actuating and holding a button of the light switch.

5

11. A computer program product for a computing device, the computer program product comprising computer program code to perform the method (400) of any of claims 1-10 when the computer program product is run on a processing unit of the computing device.

10 12. A controller (102) for controlling a lighting unit (110) of a lighting system (100a, 100b), the lighting system (100a, 100b) comprising the lighting unit (110) and a lighting control device (120) comprising a user input element (122) for receiving a continuous user input for changing an intensity of the light output of the lighting unit (110), the controller (102) comprising:

15 a communication unit (104) for receiving a signal indicative of the continuous user input,

a processor (106) configured to control the intensity of the light output of the lighting unit (110), wherein the processor (106) is further configured to:

20 - obtain parameters, the parameters comprising at least a current light setting of the lighting unit (110) and a current time, the current light setting having an intensity level between a maximum intensity level and a minimum intensity level of the lighting unit (110), and

25 - controlling the intensity of the light output of the lighting unit (110) over time while the continuous user input is being provided, wherein the intensity of the light output is either increased or decreased based on the parameters comprising at least the current light setting of the lighting unit (110) and the current time.

13. The controller (102) of claim 12, wherein the controller (102) is comprised in the lighting control device (120).

1/3

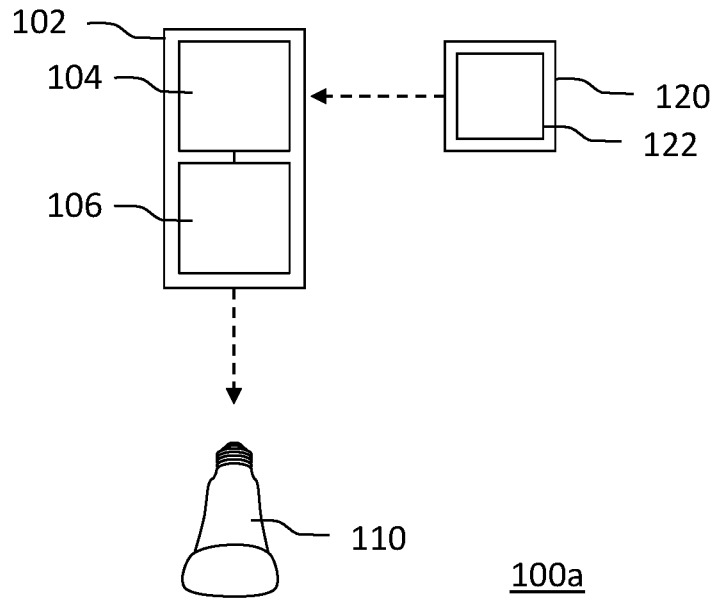

Fig. 1a

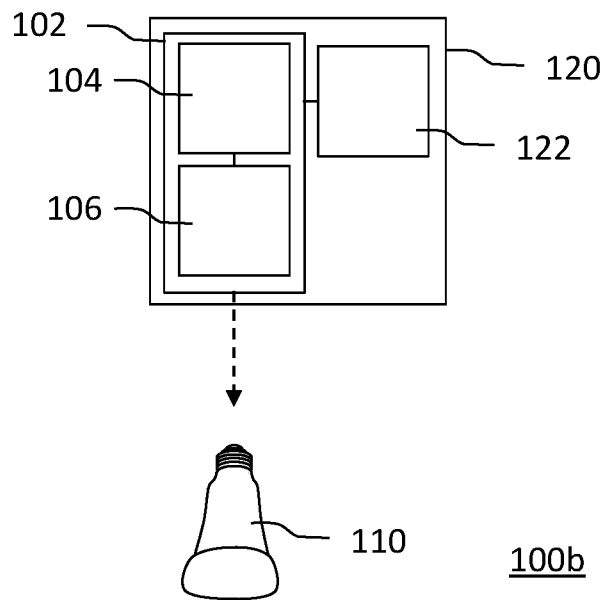

Fig. 1b

2/3

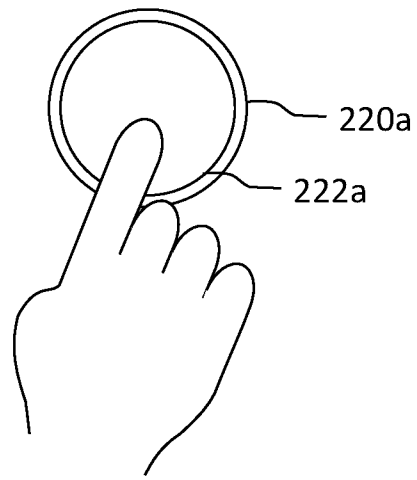

Fig. 2

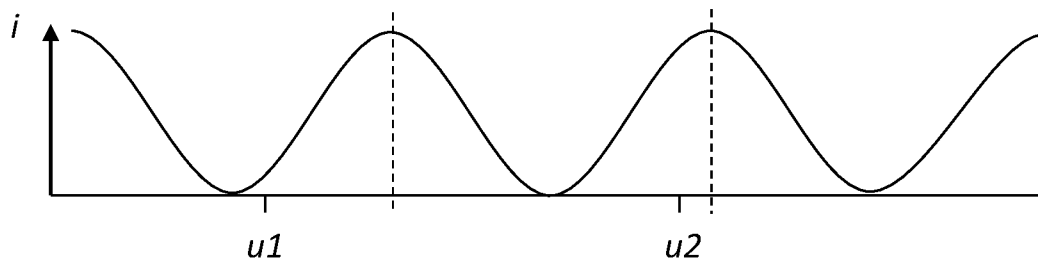

Fig. 3

3/3



400

Fig. 4

**INTERNATIONAL SEARCH REPORT**

International application No  
PCT/EP2020/071822

**A. CLASSIFICATION OF SUBJECT MATTER**  
 INV. H05B47/16 H05B47/105 H05B45/10 H05B47/175  
 ADD.  
 According to International Patent Classification (IPC) or to both national classification and IPC

**B. FIELDS SEARCHED**  
 Minimum documentation searched (classification system followed by classification symbols)  
 H05B

Documentation searched other than minimum documentation to the extent that such documents are included in the fields searched

Electronic data base consulted during the international search (name of data base and, where practicable, search terms used)  
 EPO-Internal, WPI Data

**C. DOCUMENTS CONSIDERED TO BE RELEVANT**

Category*	Citation of document, with indication, where appropriate, of the relevant passages	Relevant to claim No.
X	US 9 113 513 B1 (JUNGWIRTH PAUL [CA]) 18 August 2015 (2015-08-18) column 19, line 7 - column 21, line 47; figures 11-12, 13-I, 13-II -----	1-7,11, 12
X	US 2007/126368 A1 (MCDONOUGH BRIDGET [US] ET AL) 7 June 2007 (2007-06-07) paragraph [0063] - paragraph [0067]; figures 2B, 3, 4A, 4B, 4C -----	1-4,8-13

Further documents are listed in the continuation of Box C.

See patent family annex.

\* Special categories of cited documents :

- "A" document defining the general state of the art which is not considered to be of particular relevance
- "E" earlier application or patent but published on or after the international filing date
- "L" document which may throw doubts on priority claim(s) or which is cited to establish the publication date of another citation or other special reason (as specified)
- "O" document referring to an oral disclosure, use, exhibition or other means
- "P" document published prior to the international filing date but later than the priority date claimed

- "T" later document published after the international filing date or priority date and not in conflict with the application but cited to understand the principle or theory underlying the invention
- "X" document of particular relevance; the claimed invention cannot be considered novel or cannot be considered to involve an inventive step when the document is taken alone
- "Y" document of particular relevance; the claimed invention cannot be considered to involve an inventive step when the document is combined with one or more other such documents, such combination being obvious to a person skilled in the art
- "&" document member of the same patent family

Date of the actual completion of the international search

8 September 2020

Date of mailing of the international search report

24/09/2020

Name and mailing address of the ISA/

European Patent Office, P.B. 5818 Patentlaan 2  
 NL - 2280 HV Rijswijk  
 Tel. (+31-70) 340-2040,  
 Fax: (+31-70) 340-3016

Authorized officer

Erskine, Andrew

# INTERNATIONAL SEARCH REPORT

Information on patent family members

International application No PCT/EP2020/071822
---

Patent document cited in search report	Publication date	Patent family member(s)	Publication date
US 9113513	B1	18-08-2015	US 9113513 B1 18-08-2015
			US 9402289 B1 26-07-2016
-----			
US 2007126368	A1	07-06-2007	AU 2005275076 A1 23-02-2006
			BR PI0513309 A 06-05-2008
			CA 2573767 A1 23-02-2006
			CA 2662642 A1 23-02-2006
			CN 101014913 A 08-08-2007
			EP 1776620 A1 25-04-2007
			EP 2170017 A2 31-03-2010
			IL 180704 A 28-04-2011
			JP 2008507094 A 06-03-2008
			US 2006012315 A1 19-01-2006
			US 2007126368 A1 07-06-2007
			WO 2006019918 A1 23-02-2006
-----			