

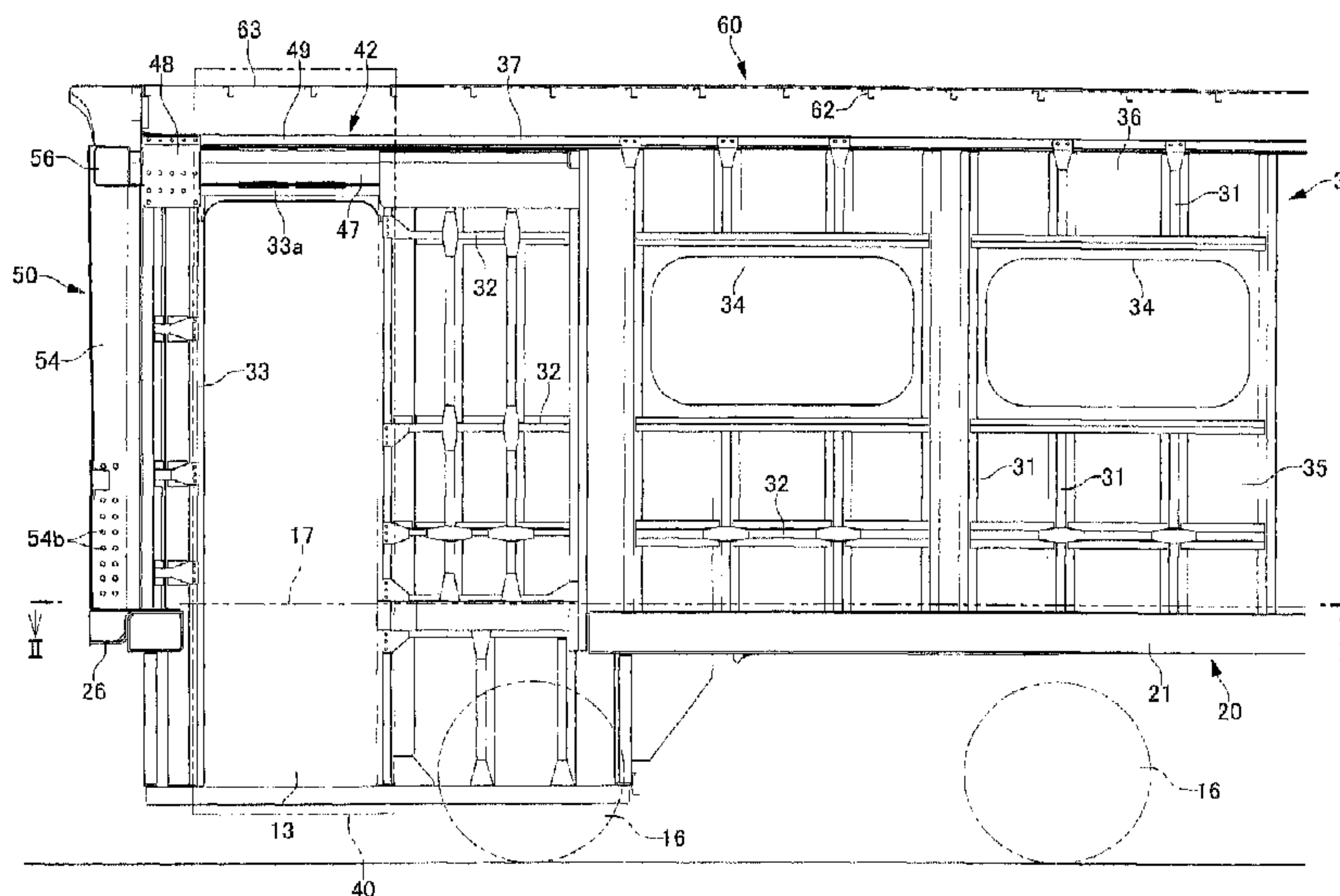

(86) Date de dépôt PCT/PCT Filing Date: 2011/04/15
 (87) Date publication PCT/PCT Publication Date: 2011/11/17
 (45) Date de délivrance/Issue Date: 2017/11/21
 (85) Entrée phase nationale/National Entry: 2012/11/05
 (86) N° demande PCT/PCT Application No.: JP 2011/059339
 (87) N° publication PCT/PCT Publication No.: 2011/142208
 (30) Priorités/Priorities: 2010/05/10 (JP2010-108143);
 2010/05/10 (JP2010-108142)

(51) Cl.Int./Int.Cl. *B61D 15/06* (2006.01),
B61D 17/06 (2006.01), *B61D 17/08* (2006.01),
B61F 1/10 (2006.01)
 (72) Inventeurs/Inventors:
 NAKAO, KOJI, JP;
 HAYASHI, KENTARO, JP;
 ISHIZUKA, TAKASHI, JP;
 KURODA, MASARU, JP
 (73) Propriétaire/Owner:
 NIPPON SHARYO, LTD., JP
 (74) Agent: MARKS & CLERK

(54) Titre : VEHICULE FERROVIAIRE
 (54) Title: RAILWAY VEHICLE



(57) Abrégé/Abstract:

Provided is a railway vehicle having a configuration which can sufficiently protect the cabin even when large external force is applied to the end structures thereof. An end structure 50 is disposed at an end portion of the vehicle body 11 through a crushable zone 40. The end structure is provided with an end post, corner posts, and an upper reinforcement beam 56. The lower end portions of the end post and the corner posts are joined to an end beam 26 of an underframe, and the upper end portions of the end post and the corner posts are joined to the upper reinforcement beam, respectively. In the crushable zone, there are provided a lower slide portion and an upper slide portion. The lower slide portion is configured by connecting a slide center beam projecting from a center portion of an end beam of the underframe in a direction of a cap beam with a guide center beam projecting from the cap beam in a vehicle end direction by a lower fuse member. The upper slide portion is configured by connecting a slide bar projecting from the upper reinforcement beam with a guide frame disposed at a side structure upper portion by an upper fuse member. The strength of each fuse member is set such that the fuse member is broken when a load over a preliminary set compressive load is applied to the end structure.

ABSTRACT

Provided is a railway vehicle having a configuration which can sufficiently protect the cabin even when large external force is applied to the end structures thereof. An end structure 50 is disposed at an end portion of the vehicle body 11 through a crushable zone 40. The end structure is provided with an end post, corner posts, and an upper reinforcement beam 56. The lower end portions of the end post and the corner posts are joined to an end beam 26 of an underframe, and the upper end portions of the end post and the corner posts are joined to the upper reinforcement beam, respectively. In the crushable zone, there are provided a lower slide portion and an upper slide portion. The lower slide portion is configured by connecting a slide center beam projecting from a center portion of an end beam of the underframe in a direction of a cap beam with a guide center beam projecting from the cap beam in a vehicle end direction by a lower fuse member. The upper slide portion is configured by connecting a slide bar projecting from the upper reinforcement beam with a guide frame disposed at a side structure upper portion by an upper fuse member. The strength of each fuse member is set such that the fuse member is broken when a load over a preliminary set compressive load is applied to the end structure.

DESCRIPTION
RAILWAY VEHICLE

Technical Field

[0001]

The present invention relates to a railway vehicle, particularly, a railway vehicle which can protect a cabin from a shock caused by a collision, or derailment and overturn.

Background Art

[0002]

A vehicle body of a railway vehicle is configured by joining side structures and end structures to the four side portions of an underframe, respectively, joining a roof structure to the upper portions of the side structures and the end structures, and disposing outer plates, floor boards, interior materials, doors, and windows, on the respective structures. In a conventional railway vehicle, as countermeasures for collisions, the end structures and the underframe portion are reinforced, and shock absorption members are disposed, thereby protecting the cabin (e.g., refer to Patent Literature 1).

Citation List

Patent Literature

[0003]

Patent Literature 1: Japanese Patent Application Laid-Open No. 2001-48016

SUMMARY OF INVENTION

[0004]

However, when large external force is applied to the side structures or the end structures due to a collision etc., the side structures and the end structures may be greatly deformed or damaged so that the cabin cannot be sufficiently protected.

[0005]

Then, the present invention is intended to provide a railway vehicle having a configuration which can sufficiently protect the cabin even when large external force is applied to the side structure or the end structure.

[0006]

In view of the above mentioned object, according to an aspect of the present invention there is provided a railway vehicle which is configured by joining an underframe, side structures, end structures, and a roof structure, so as to form a vehicle body, wherein a crushable zone is disposed at an end portion of the vehicle body, wherein a slide bar is respectively projected from a corresponding upper end portion of each of the end structures horizontally along upper portions of the side structures, wherein the side structures are provided at upper portions thereof with guide frames which hold the slide bars so as to be slidable in vehicle body front and back directions, wherein in the crushable zone, there are provided slidably in vehicle body front and back directions a slide center beam configured to project from a center portion of an end beam of the underframe in a horizontal direction toward a direction of a cap beam disposed at the underframe, and a guide center beam configured to horizontally project from the cap beam in a vehicle end direction, wherein the slide bars are slidable in the vehicle body front and back directions and each slide bar is

configured to project from a corresponding end portion of an upper reinforcement beam in a horizontal direction along a side structure upper portion, and wherein there is provided a guide frame disposed at the side structure upper portion, wherein the slide center beam and the guide center beam are connected with each other by a lower fuse member, and the slide bar and the guide frame are connected with each other by an upper fuse member, wherein a strength of each of the fuse members is set such that the fuse member is broken when a load over a preliminary set load is applied to the end structure so that the lower slide portion and the upper slide portion are brought into a slidable state.

[0007]

Moreover, in the railway vehicle of the present invention, the crushable zone is a vestibule including a passenger door disposed at a rear portion of the end structure. The slide bar passes through a lintel portion of a door frame portion of the passenger door. The guide frame is disposed at an upper portion of a door pocket portion disposed at the side structure.

[0008]

The end structure is provided with an end post disposed at a central portion thereof in a width direction; a pair of corner posts; each corner post being respectively disposed at a corresponding one of said end portions thereof in the width direction; and an upper reinforcement beam disposed at an upper portion of the end structure in a railroad tie direction.

[0009]

The lower end portions of the end post and the corner post are joined to an end beam of the underframe, and the upper end portions of the end post and the corner post are joined to the upper reinforcement beam, respectively.

[0010]

A shock absorption member is disposed between the slide center beam and the cap beam.

[0011]

According to the railway vehicle of the present invention, even when external force is applied to the end structure from various directions, such as a front direction, an inclined direction or a portion thereof, external force can be born by the entire end structure which is rigidly assembled in a frame by connecting the end beam of the underframe and the upper reinforcement beam with the end post and the corner post, respectively.

[0012]

Moreover, the end structure can be moved parallel to the vehicle body backward direction by the lower slide portion and the upper slide portion, thereby, the end structure is prevented from falling down toward the cabin, and the damage of the cabin can be suppressed. When the vestibule portion disposed at the rear portion of the end structure is configured as the crushable zone, the movement of the end structure toward the cabin side can be absorbed by the crushable zone, thereby the damage of the cabin can be more surely suppressed. The strength of the entire end structure can be enhanced by providing the upper reinforcement beam at the upper portion of the end structure.

[0013]

Moreover, by providing the fuse member, the end structure can be maintained at a predetermined strength. By providing the shock absorption member between the slide center beam and the cap beam, the external force applied to the end structure can be effectively absorbed.

BRIEF DESCRIPTION OF DRAWINGS

[0014]

FIG. 1 is a side view of a vehicle structure illustrating an embodiment of the present invention.

FIG. 2 is a II-II cross-sectional view of FIG. 1.

FIG. 3 is an explanatory diagram of a main portion illustrating a joining state between a side post and an underframe.

FIG. 4 is a IV-IV cross-sectional view of FIG. 3.

FIG. 5 is a front view of the vehicle structure.

FIG. 6 is a VI-VI cross-sectional view of FIG. 5.

FIG. 7 is a VII-VII cross-sectional view of FIG. 5.

FIG. 8 is a VIII-VIII cross-sectional view of FIG. 5.

FIG. 9 is an explanatory diagram illustrating a state of assembling between an end post and a post reinforcement member, and between a corner post and a post reinforcement member.

FIG. 10 is a front view of the underframe of the vehicle structure.

FIG. 11 is a XI-XI cross-sectional view of FIG. 10.

FIG. 12 is a XII-XII cross-sectional view of FIG. 10.

FIG. 13 is a side view of a main portion of the vehicle structure.

FIG. 14 is a XIV-XIV cross-sectional view of FIG. 13.

FIG. 15 is a XV-XV cross-sectional view of FIG. 13.

FIG. 16 is a XVI-XVI cross-sectional view of FIG. 13.

FIG. 17 is a cross-sectional view of a main portion of a lower slide portion.

FIG. 18 is a perspective view of a shock absorption member.

FIG. 19 is a side view of a railway vehicle.

FIG. 20 is a front view of the railway vehicle.

Description of Embodiments

[0015]

A vehicle body 11 of a railway vehicle as described in the present embodiment is provided with an underframe 20, a pair of

right and left side structures 30 disposed on both sides of the underframe 20 in the longitudinal directions, end structures 50 disposed on the end portions of the vehicle body 11 through crushable zones 40, and a roof structure 60 disposed so as to cover the upper portions of the side structures 30 and the end structures 50. At both front and rear end portions of the side faces of the vehicle body 11, vestibules 13 having passenger doors 12 are respectively disposed, and a cabin 14 is disposed between the vestibules 13 at both ends. A plurality of side window 15 are disposed on the side walls of the cabin 14, and interior materials and seats are disposed in the cabin 14.

[0016]

The underframe 20 includes a pair of right and left side beams 21 disposed in the rail directions, center beams 23 and transverse beams 24 for reinforcement, and a pair of front and rear cap beams 22 disposed in the railroad tie directions at both front and rear end portions of the center beams 23. At the lower portion of the cap beam 22, a truck provided with wheels 16 is disposed, and a floor board 17 is disposed at the upper portion of the underframe 20. The side beam 21 is a member having a Z-shaped cross-section, and includes a projecting piece 21a which projects in the horizontal direction toward the outside of the vehicle body from the lower end portion of the side beam 21.

[0017]

The side structure 30 is provided with a plurality of side

posts 31 in the vertical directions, a plurality of frame members 32 in the front and back directions of the vehicle body, door frame portions 33 in which the passenger doors 12 are disposed, window frame portions 34 in which the side windows 15 are disposed, wainscot panels 35 disposed at the lower portions of the side windows 15, skin panels 36 disposed at the upper portions of the side windows 15, and door pocket portions 37 disposed on the cabin sides of the door frame portions 33. The lower end of the side post 31 is joined to the upper face portion of the projecting piece 21a which is disposed at the side beam 21 through a rocker rail 25, and the outer face portion 21b of the side beam 21 is joined to the lower inner face of the side post 31.

[0018]

The roof structure 60 is formed by a pair of cant rails 61 which are respectively disposed on both sides in the rail directions, a plurality of rafters 62 in the railroad tie directions which are orthogonally joined to the cant rails 61, and a shingle 63 joined to the outside of the rafters 62. Both ends of the cant rail 61 are joined to the upper portions of the end structures 50, and both ends of the rafter 62 are joined to the upper ends of the side structures 30 through the cant rails 61. The shingle 63 is formed so as to have a curved face gently projecting upward, and instruments, such as a horn 64, are disposed on the roof as appropriate.

[0019]

The end structure 50 includes an opening frame portion for door 51 for a connecting door 18 which is disposed at the center in the width direction, and opening frame portions for windows 52 for front face windows (end face windows) 19 which are respectively disposed on the right and left of the connecting door 18. A pair of end posts (central portion collision posts) 53 are respectively disposed between the opening frame portion for door 51 and each of the opening frame portions for windows 52. A pair of corner posts (end portion collision posts) 54 are respectively disposed at the outsides of the opening frame portions for windows 52 which are both end portions in the end structure width directions. At the central portion in the vertical directions of this corner post 54, a reinforcement member 52a is disposed in order to enhance the rigidity of the side portion of the end face window 19. The lower portion of the end structure 50 is rigidly joined through the end post reinforcement members 57 and corner post reinforcement members 58 to the end beam 26 disposed at each of both front and rear ends of the underframe 20 and is integrally formed therewith. Moreover, at the upper portion of the end structure 50, an upper reinforcement beam 56 is disposed in the railroad tie directions under a state of being independent from the portion joined with the roof structure 60.

[0020]

A sweep-back angle toward the side is formed at the front face window 19, and the planar view of the outer face (end face)

of the end structure 50 is formed in a triangle folded end shape whose connecting door 18 portion projects. The side face upper half portion of the end structure 50 is inclined toward the inside of the vehicle body, similar to the side structures 30.

[0021]

The end beam 26 is formed in a Z-shaped cross-section. The upper face portion thereof toward the inside of the vehicle body is provided with an upper face plate 55. The distal end of the lower projecting piece 26a horizontally projecting toward the outside of the vehicle body is formed in a shape corresponding to the triangle folded end shape of the end structure 50. With this, there is no need to perform a process for folding the entire end beam 26 so as to correspond to the shape of the end structure 50. In addition to this, the end post reinforcement member 57 and the corner post reinforcement member 58 can be rigidly fixed by welding to the end beam 26 by the projecting piece 26a.

[0022]

At the positions of the end beam 26 corresponding to the end posts 53, a pair of end post reinforcement members 57 each having height of about 1/2 of that of the end post 53 are respectively disposed. At the positions of both end portions of the end beam 26 corresponding to the corner posts 54, a pair of corner post reinforcement members 58 each having length reaching the lower frame portion of the opening frame portion for window 52 are respectively disposed. At the lower portion of the end

beam 26, a coupler support frame 59a for supporting a coupler 59 is disposed.

[0023]

The lower portion 57a of the end post reinforcement member 57 is joined to the outer faces of the end beam 26 and the end beam lower member 26c through the slits 26b which are formed in the upper face plate 55 and the projecting piece 26a, respectively. The lower end of the lower portion 58a of the corner post reinforcement member 58 is joined to the upper face of the projecting piece 26a, and the side face of the lower end portion thereof is joined to the outer face of the end beam 26. Thus, the end post reinforcement member 57 and the corner post reinforcement member 58 are joined to the outer face of the end beam 26 so that the end post reinforcement member 57 and the corner post reinforcement member 58 can be rigidly joined to the end beam 26, and external force applied to the end post reinforcement member 57 and the corner post reinforcement member 58 can be born by the end beam 26.

[0024]

Moreover, the end post reinforcement member 57 and the end post 53 are joined to each other, and the corner post reinforcement member 58 and the corner post 54 are joined to each other, so that the end post 53 and the corner post 54 can be joined to the underframe 20 with sufficient joining strength against shearing force and bending moment caused at the respective joined portions

of the end post 53 and the corner post 54 by external force applied to all vertical positions of the end post 53 and the corner post 54. Moreover, the height of each of the post reinforcement members 57, 58 is set to the height of about 1/2 of the height of the end post 53 or the corner post 54 so that loads applied to all vertical positions of the end post 53 and the corner post 54 can be effectively born, and sufficient joining strength with the underframe 20 can be held.

[0025]

At the vehicle body inner sides of the end post 53 and the corner post 54, there are respectively provided openings 53a, 54a through which the respective post reinforcement members 57, 58 can pass. The end post 53 and the corner post 54 are assembled with the respective post reinforcement members 57, 58 by inserting the respective post reinforcement members 57, 58 into the insides of the end post 53 and the corner post 54 through the openings 53a, 54a of the end post 53 and the corner post 54 which have been preliminary assembled into the end structure 50. The end post 53 and the corner post 54 are joined to the respective post reinforcement members 57, 58 by welding the inner circumferences of a plurality of joining holes 53b, 54b disposed on the side faces of the end post 53 and the corner post 54 and the side faces of the respective post reinforcement members 57, 58. Moreover, reinforcement angle 53c, 54c are joined and connected between the lower end portions of the end post 53 and the corner post 54 and

the upper face plate 55.

[0026]

At the upper portions of the end post 53 and the corner post 54, the outer sides of the end post 53 and the corner post 54 are extended upward, and these extended portions are disposed on the outer face of the upper reinforcement beam 56 so as to be joined thereto, respectively. Namely, the end beam 26 and the upper reinforcement beam 56 are connected by the end posts 53 and the corner posts 54 which are joined to their outer faces, so that the overall rigidity of the end structure 50 is enhanced by assembling in a frame the end beam 26, the upper reinforcement beam 56, a pair of end posts 53, and a pair of corner posts 54. Moreover, the post reinforcement members 57, 58 are respectively disposed at the lower portions of the end post 53 and the corner posts 54, and the lower portions of the respective post reinforcement members 57, 58 are joined to the outer face of the end beam 26, so that the rigidity of the end structure 50 is further enhanced.

[0027]

The thus formed end structure 50 is joined to the end beam 26 and the upper face plate 55 connected to the slide center beam 43, and is disposed at the end portion of the vehicle body 11 through the crushable zone 40 which is disposed at the vestibule 13 portion. At the upper and lower sides of this crushable zone 40, a lower slide portion 41 and an upper slide portion 42 are

disposed.

[0028]

The lower slide portion 41 is connected to the central portion in the width directions of the end beam 26. The slide center beam 43, which is disposed so as to horizontally project in a substantially T letter-shape in a planar view toward the direction of the cap beam 22, is disposed so as to be slidable in the vehicle body front and back directions through support members 43a, 44a with respect to a guide center beam 44 projecting horizontally toward the direction of the vehicle end from the cap beam 22, and is connected by a lower fuse member which is designed so as to be broken when the load exceeds a preliminary set value.

[0029]

The upper slide portion 42 is provided with slide bars 47 which horizontally project along lintel portions 33a of the door frame portion 33 from both end portions of the upper reinforcement beam 56, and guide frames 48 disposed at the upper portions of the door pocket portions 37. The slide bar 47 is disposed so as to be slidable in the vehicle body front and back directions with respect to the guide frame 48, and similar to the lower slide portion 41, the slide bar 47 and the guide frame 48 are connected with each other by an upper fuse member which is designed so as to be broken when the load exceeds a preliminary set value.

[0030]

Each of the fuse members is a member having strength for

bearing preliminary set tensile load and compressive load. The strength of the fuse member is set such that the fuse member is not permanently deformed or broken by the normal tensile load or compressive load which is applied when a plurality of railway vehicles are used by connecting with one another by the couplers 59, and is broken when an excessive load over the preliminary set load is applied by a collision. Namely, when the fuse member is broken due to an application of an excessive load, the slide center beam 43 and the slide bar 47 become slidable with respect to the guide center beam 44 and the guide frame 48 so that energy is absorbed by crushing a plurality of shock absorption members 45 disposed in the underframe 20.

[0031]

The strength of respective members disposed at the vestibule portion, for example, the strength at the vestibule portions of the door frame portion 33, the floor board 17, and the roof structure 60, is set at strength lower than the strength of the fuse member, such that when the fuse member is broken by an application of an excessive load, the vestibule portions of the door frame portion 33, the floor board 17, and the roof structure 60 are deformed at the same time of the break of the fuse member.

[0032]

The shock absorption member 45 can be made by combining, for example, four long shock absorbers 45a made of square pipes each having the same shape of square cross-section and two short

shock absorbers 45b each having a length shorter than the length of the long shock absorber 45a so as to make the axes of the respective shock absorbers 45a, 45b parallel with each other. The proximal end of each of the shock absorbers 45a, 45b is integrally joined to a mounting plate 45c. The mounting plate 45c is mounted on the end faces of the cap beam 22 and the guide center beam 44, and the axes of the respective shock absorbers 45a, 45b are disposed so as to be oriented in the vehicle body front and back directions. At the distal end of each of the shock absorbers 45a, 45b, cutout portions 45d are respectively formed in the distal edges of a set of opposing faces between two sets of opposing faces. The respective shock absorbers 45a, 45b are combined such that the respective cutout portions 45d themselves are not adjacent to each other.

[0033]

Thus formed shock absorber 45 is deformed at the time of collision first at the opposing edges of the long shock absorber 45a where the cutout portion 45d is not disposed. Subsequently, the opposing edges of the short shock absorber 45b where the cutout portion 45d is not disposed start to be deformed by an application of collision. The deformations of the respective shock absorbers 45a, 45b are continuously repeated toward the proximal end side while mutually influencing the wall face of adjacent shock absorber. With this, a shock can be absorbed by continuously making the wall faces of the respective shock absorbers 45a, 45b

buckled into a bellows-like state. Moreover, because a plurality of shock absorbers are disposed and joined in the width directions and the vertical directions, the bending rigidity of the shock absorption member 45 is enhanced so that the intermediate portion can be prevented from being bent, thereby the collision energy can be surely absorbed.

[0034]

Thus, the end beam 26, to which the lower portion of the end structure 50 is joined, is held so as to be slidable in the vehicle body front and back directions by the lower slide portion 41 which is formed by the slide center beam 43 and the guide center beam 44. The upper reinforcement beam 56 disposed at the upper portion of the end structure 50 is held so as to be slidable in the vehicle body front and back directions by the upper slide portion 42 which is formed by the slide bar 47 and the guide frame 48 which are disposed on both sides of the vehicle body. The end beam 26 and the upper reinforcement beam 56 are rigidly connected with each other by the end post 53 and the corner post 54. Moreover, at the lower portion of the end post 53 and the corner post 54, the post reinforcement members 57, 58 are respectively disposed for enhancing the rigidities of the end post 53 and the corner post 54. Accordingly, the end beam 26, the upper reinforcement beam 56, the end post 53, and the corner post 54 are rigidly joined to one another, and the end post 53 and the corner post 54 are disposed at the front faces of the end beam 26 and the upper

reinforcement beam 56, thereby the end structure 50 becomes a state of being rigidly assembled in a frame.

[0035]

With this, even when large external force is applied from the front direction to the end structure 50, large external force is applied from an oblique direction to the end structure 50, and/or large external force is applied to a part of the end structure 50, the external force can be born by the entire end structure 50, and the end structure 50 can be moved parallel to the vehicle body backward direction by the lower slide portion 41 and the upper slide portion 42, thereby, the end structure 50 is prevented from falling down toward the cabin 14.

[0036]

Moreover, the end post 53 and the corner post 54 are joined to the upper reinforcement beam 56 and the outer face of the end beam 26 so that external force applied to the end post 53 and the corner post 54 can be surely transmitted to the upper reinforcement beam 56 and the end beam 26. The lower end of the lower portion of the corner post reinforcement member 58 is joined to the upper face of the projecting piece 26a, and the side face of the lower end portion thereof is joined to the outer face of the end beam 26, so that the joining strength between the corner post reinforcement member 58 and the end beam 26 can be enhanced, compared with the case in which the corner post reinforcement member 58 is disposed so as to stand on the upper face of the end

beam 26. Thereby, external force to the end face can be effectively transmitted to the entire end structure 50 and the end beam 26.

[0037]

Therefore, regardless of the application direction of external force applied to the end structure 50 and the application position thereof, the end structure 50 can be moved parallel to the vehicle body backward direction while the vestibule 13 portion, which is a crushable zone, is being deformed. Therefore, external force is applied to the shock absorption member 45 in the axial directions of the respective shock absorbers 45a, 45b. Thereby, as mentioned above, the respective shock absorbers 45a, 45b can be surely deformed to be buckled so that the external force absorbing effect by the shock absorption member 45 can be fully used. Thus, the cabin 14 can be protected by deforming only the vestibule 13 portion which is disposed at the vehicle end portion so as to absorb collision energy.

[0038]

Moreover, the lower end of the side post 31 of the side structure 30 is joined to the upper face portion of the projecting piece 21a which is disposed at the side beam 21 of the underframe 20, and the lower inner face of the side post 31 is joined to the outer face portion 21b of the side beam 21. Thereby, the external force applied to the side structure 30 from the side of the vehicle body can be born by the outer face portion 21b of the side beam

21 through the lower end portion of the side post 31. Accordingly, the joining strength between the side post 31 and the side beam 21 can be enhanced, compared with the case in which the lower end of the side post 31 is joined to the upper face of the side beam 21, and the underframe 20 and the side structure 30 can be rigidly joined to each other. Thereby, the deformation of the side structure 30 toward the inside of the vehicle body can be suppressed even when large external force is applied to the side face portion of the vehicle body. Moreover, the external force applied to the roof structure 60 from above can be born by the projecting piece 21a of the side beam 21 through the side post 31, so that the deformation of the roof structure 60 toward the inside of the vehicle body by external force from above can be suppressed.

[0039]

The end post 53 and the corner post 54 are assembled with the respective post reinforcement members 57, 58 by inserting the respective post reinforcement members 57, 58 into the insides of the end post 53 and the corner post 54 through the openings 53a, 54a which are formed at the vehicle body inner sides of the end post 53 and the corner post 54, so that the end structure 50 can be assembled by moving the same in the horizontal direction. With this, the end structure 50 and the underframe 20 can be combined under a state in which the end post 53 and the corner post 54 are preliminary assembled into the end structure 50 which can have

various vehicle body cross-sections, so that the respective post reinforcement members 57, 58 can be easily assembled with the end post 53 and the corner post 54. Moreover, an end structure whose end post 53 and corner post 54 are inclined can be addressed.

[0040]

Note that, at the front head portion of the vehicle body, a driver's cab and a crew's room are disposed at the vestibule 13 portion, and a hood and a marker light, etc. are disposed at the end face. The end post 53 can be disposed at a suitable position according to the existence or non-existence of the connection door 18 or the shape of the end face window 19, and can be single. Moreover, suitable configurations can be adopted for the configuration of the shock absorption member 45 and the configurations of the respective connection members 46 and the upper connection member 49.

Reference Signs List

[0041]

11... vehicle body, 12... passenger door, 13... vestibule, 14... cabin, 15... side window, 16... wheel, 17... floor board, 18... connecting door, 19... end face window, 20... underframe, 21... side beam, 21a... projecting piece, 21b... outer face portion, 22... cap beam, 23... center beam, 24... transverse beam, 25... rocker rail, 26... end beam, 26a... projecting piece, 26b... slit, 30... side structure, 31... side post, 32... frame member, 33... door frame portion, 33a... lintel portion, 34... window frame portion, 35... wainscot panel, 36... skin panel, 37... door pocket

portion, 40... crushable zone, 41... lower slide portion, 42... upper slide portion, 43... slide center beam, 44... guide center beam, 45... shock absorption member, 45a... long shock absorber, 45b... short shock absorber, 45c... mounting plate, 45d... cutout portion, 47... slide bar, 48... guide frame, 50... end structure, 51... opening frame portion for door, 52... opening frame portion for window, 52a... reinforcement member, 53... end post, 54... corner post, 53a, 54a... opening, 53b, 54b... joining hole, 53c, 54c... reinforcement angle, 55... upper face plate, 56... upper reinforcement beam, 57... end post reinforcement member, 58... corner post reinforcement member, 59... coupler, 59a... coupler support frame, 60... roof structure, 61... cant rail, 62... rafter, 63... shingle, 64... horn

The embodiments of the invention in which an exclusive property or privilege is claimed are defined as follows:

1. A railway vehicle which is configured by joining an underframe, side structures, end structures, and a roof structure, so as to form a vehicle body, wherein a crushable zone is disposed at an end portion of the vehicle body, wherein a slide bar is respectively projected from a corresponding upper end portion of each of the end structures horizontally along upper portions of the side structures, wherein the side structures are provided at upper portions thereof with guide frames which hold the slide bars so as to be slidable in vehicle body front and back directions,

wherein in the crushable zone, there are provided slidably in vehicle body front and back directions a slide center beam configured to project from a center portion of an end beam of the underframe in a horizontal direction toward a direction of a cap beam disposed at the underframe, and a guide center beam configured to horizontally project from the cap beam in a vehicle end direction, wherein the slide bars are slidable in the vehicle body front and back directions and each slide bar is configured to project from a corresponding end portion of an upper reinforcement beam in a horizontal direction along a side structure upper portion, and wherein there is provided a guide frame disposed at the side structure upper portion,

wherein the slide center beam and the guide center beam are connected with each other by a lower fuse member, and the slide bar and the guide frame are connected with each other by an upper fuse member, wherein a strength of each of the fuse members is set such that the fuse member

is broken when a load over a preliminary set load is applied to the end structure so that the lower slide portion and the upper slide portion are brought into a slidable state.

2. The railway vehicle according to claim 1, wherein the crushable zone is a vestibule including a passenger door disposed at a rear portion of the end structure, wherein the slide bar passes through a lintel portion of a door frame portion of the passenger door, and wherein the guide frame is disposed at an upper portion of a door pocket portion disposed at the side structure.

3. The railway vehicle according to claim 1 or 2, wherein the end structure is provided with: an end post disposed at a central portion thereof in a width direction; a pair of corner posts; each corner post being respectively disposed at a corresponding one of said end portions thereof in the width direction; and an upper reinforcement beam disposed at an upper portion of the end structure in a railroad tie direction.

4. The railway vehicle according to any one of claims 1 to 3, wherein lower end portions of an end post and a corner post are joined to an end beam of the underframe, and upper end portions of the end post and the corner post are joined to the upper reinforcement beam, respectively.

5. The railway vehicle according to any one of claims 1 to 4, wherein a shock absorption member is disposed between the slide center beam and the cap beam.

FIG.2

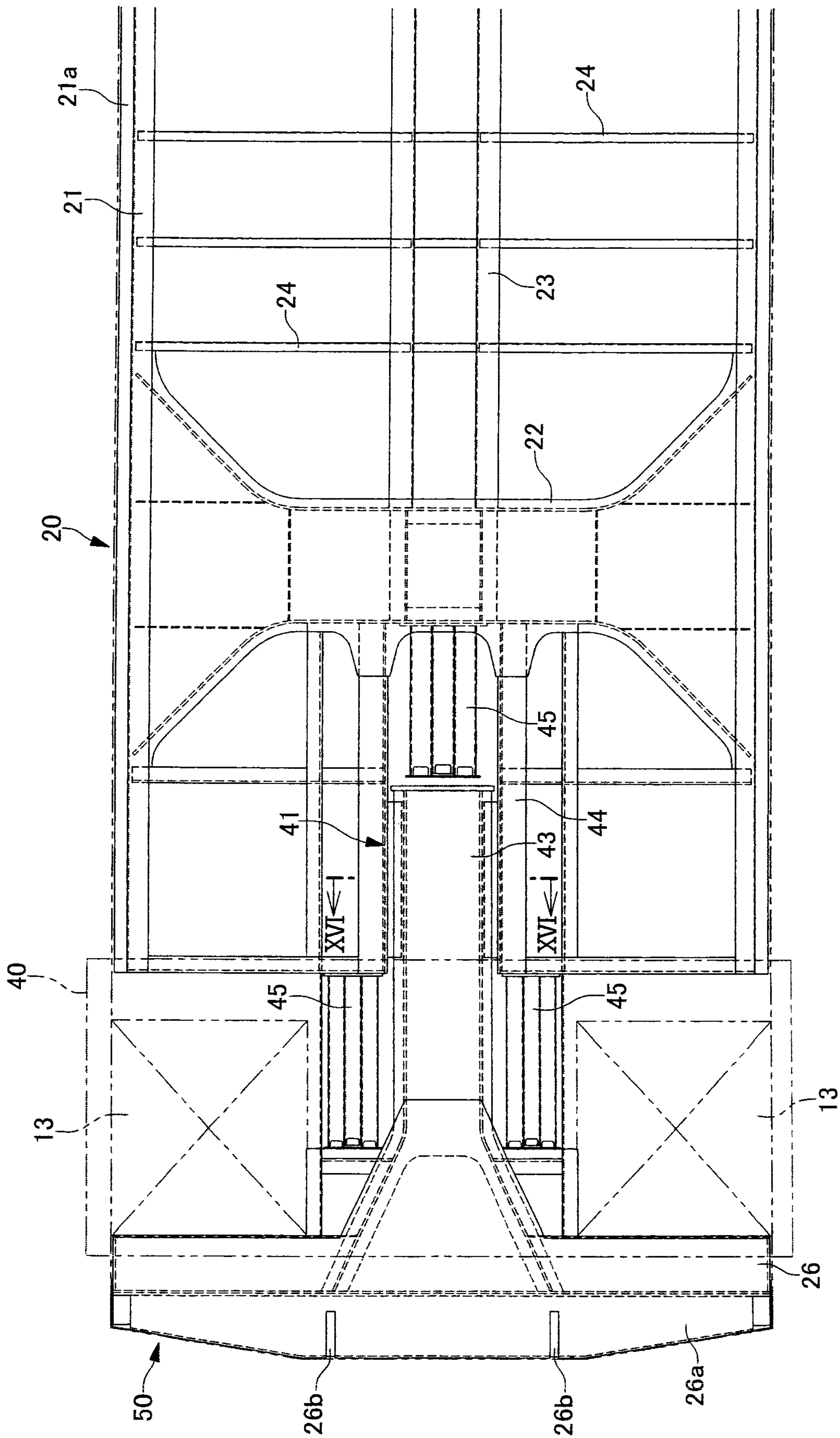

FIG.3

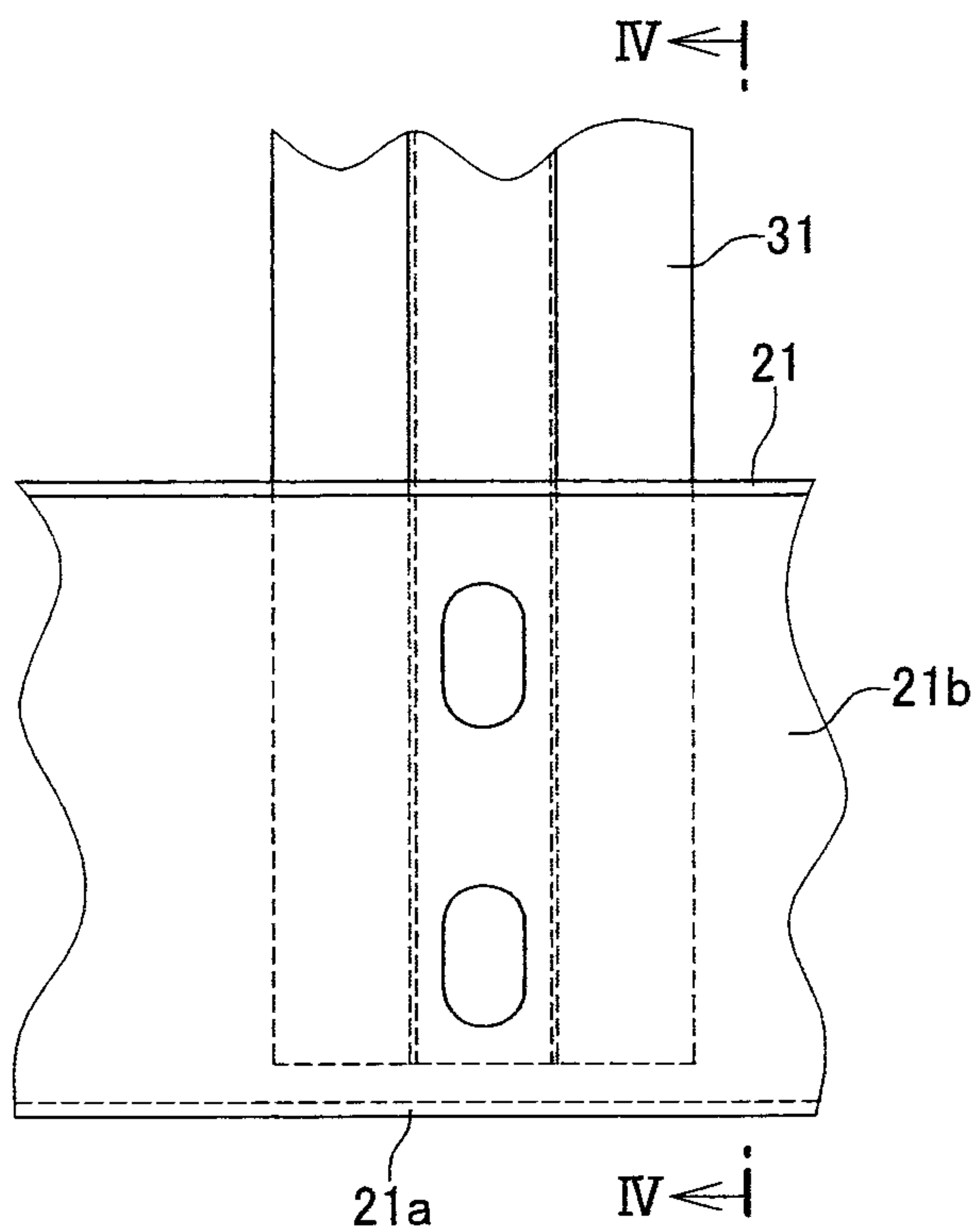

FIG.4

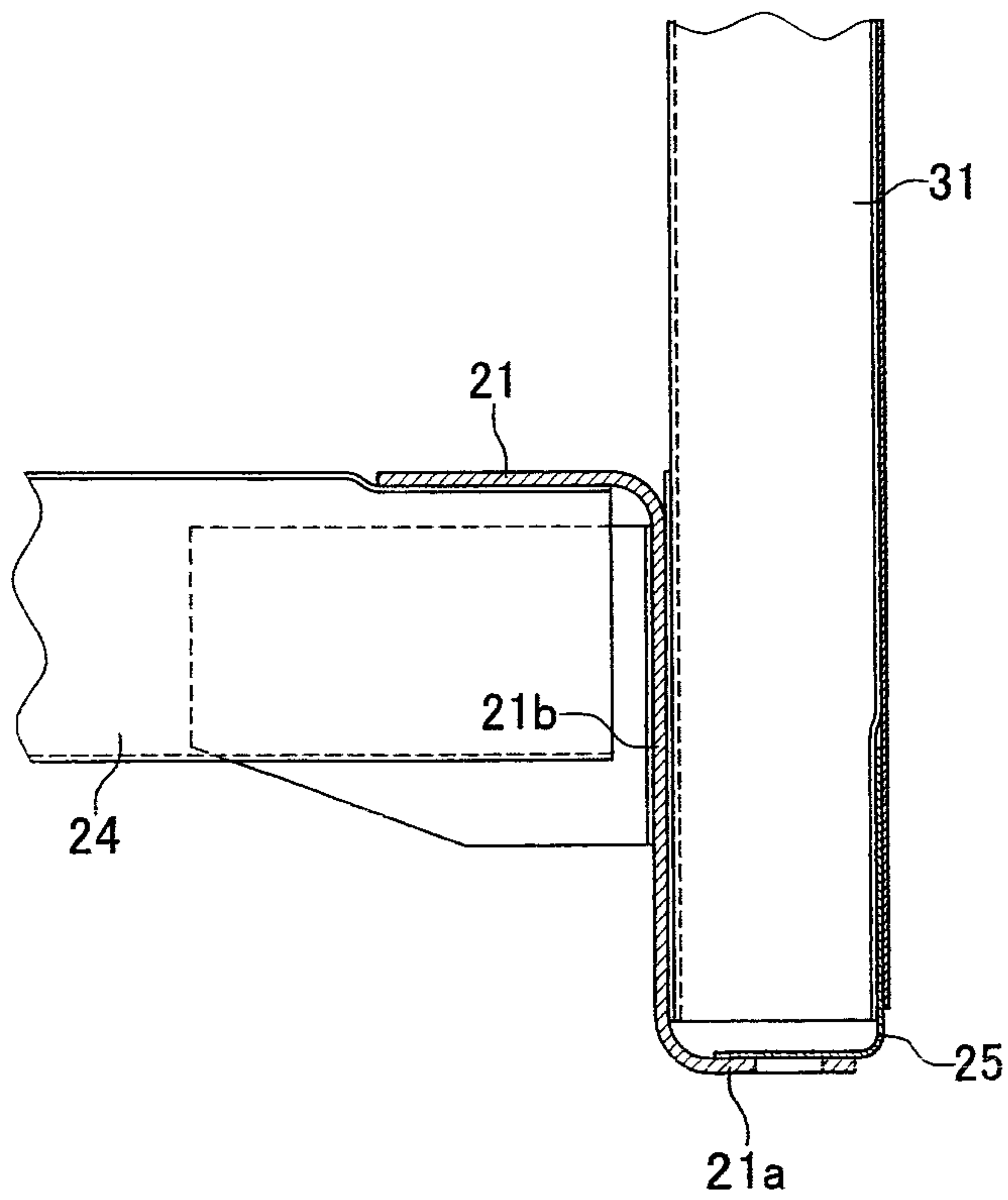

FIG.5

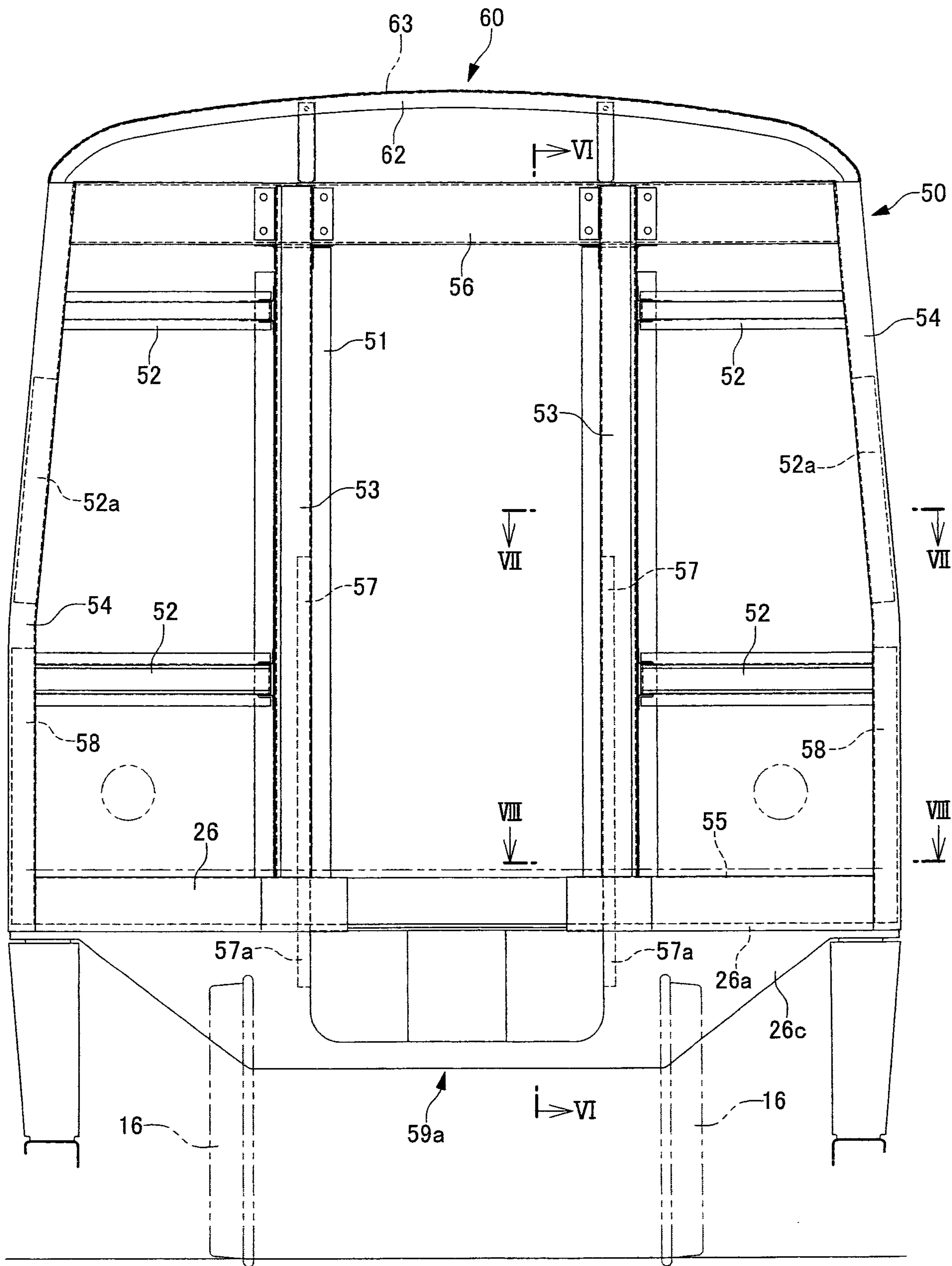

FIG.6

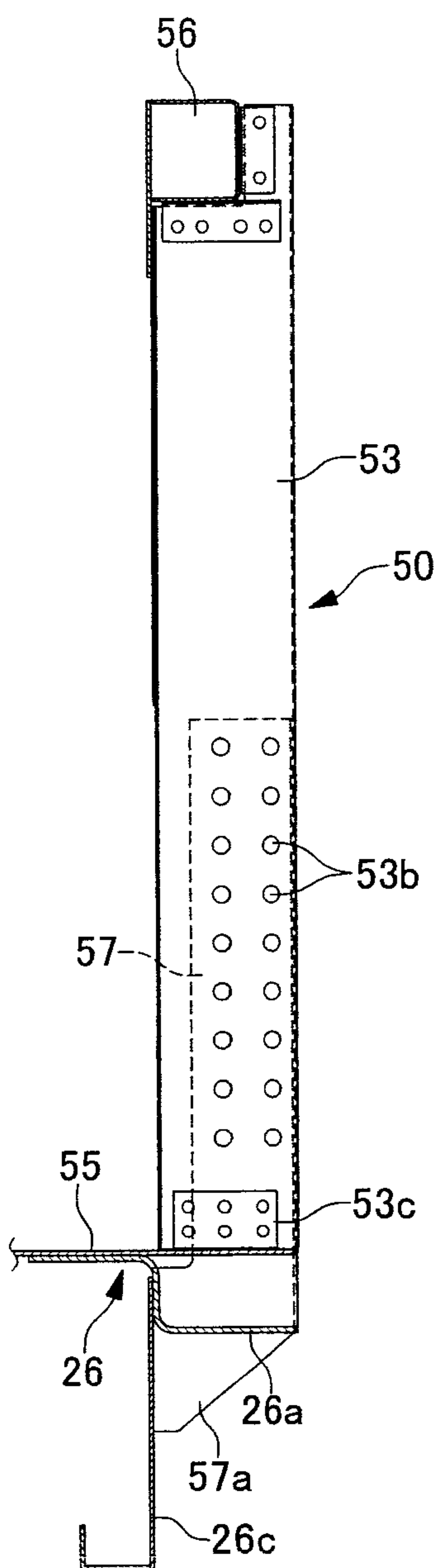

FIG.7

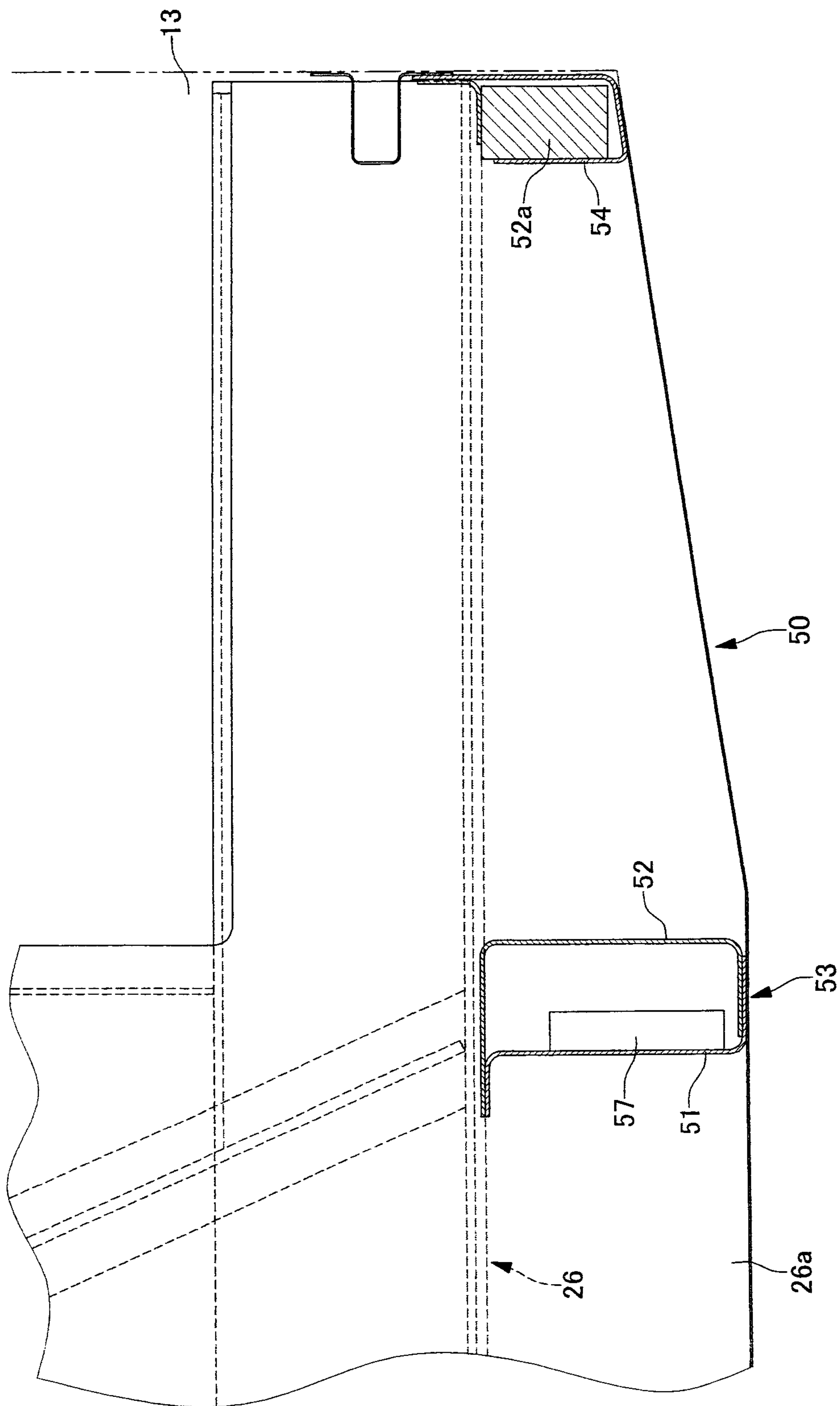

FIG.8

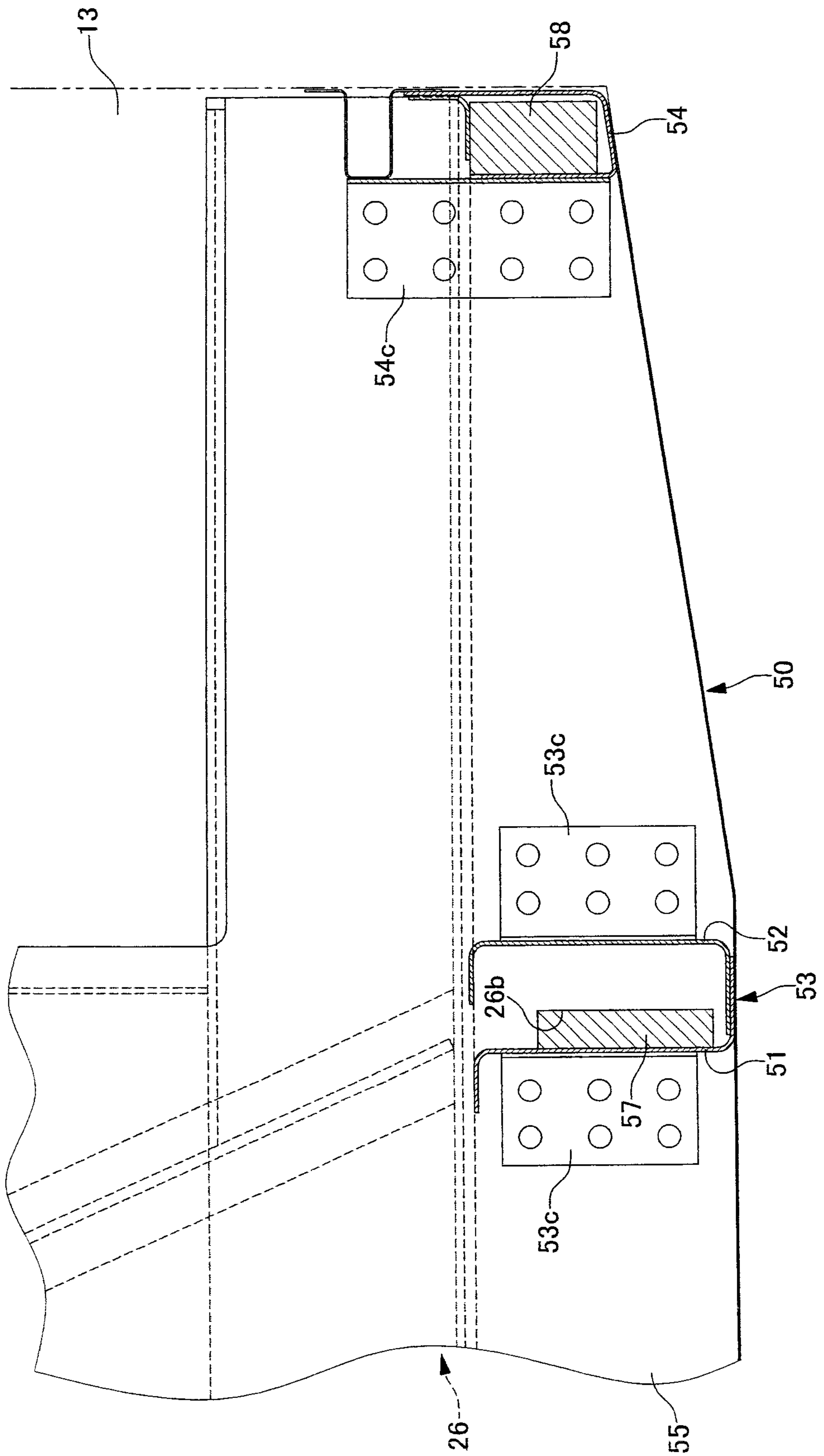

FIG.9

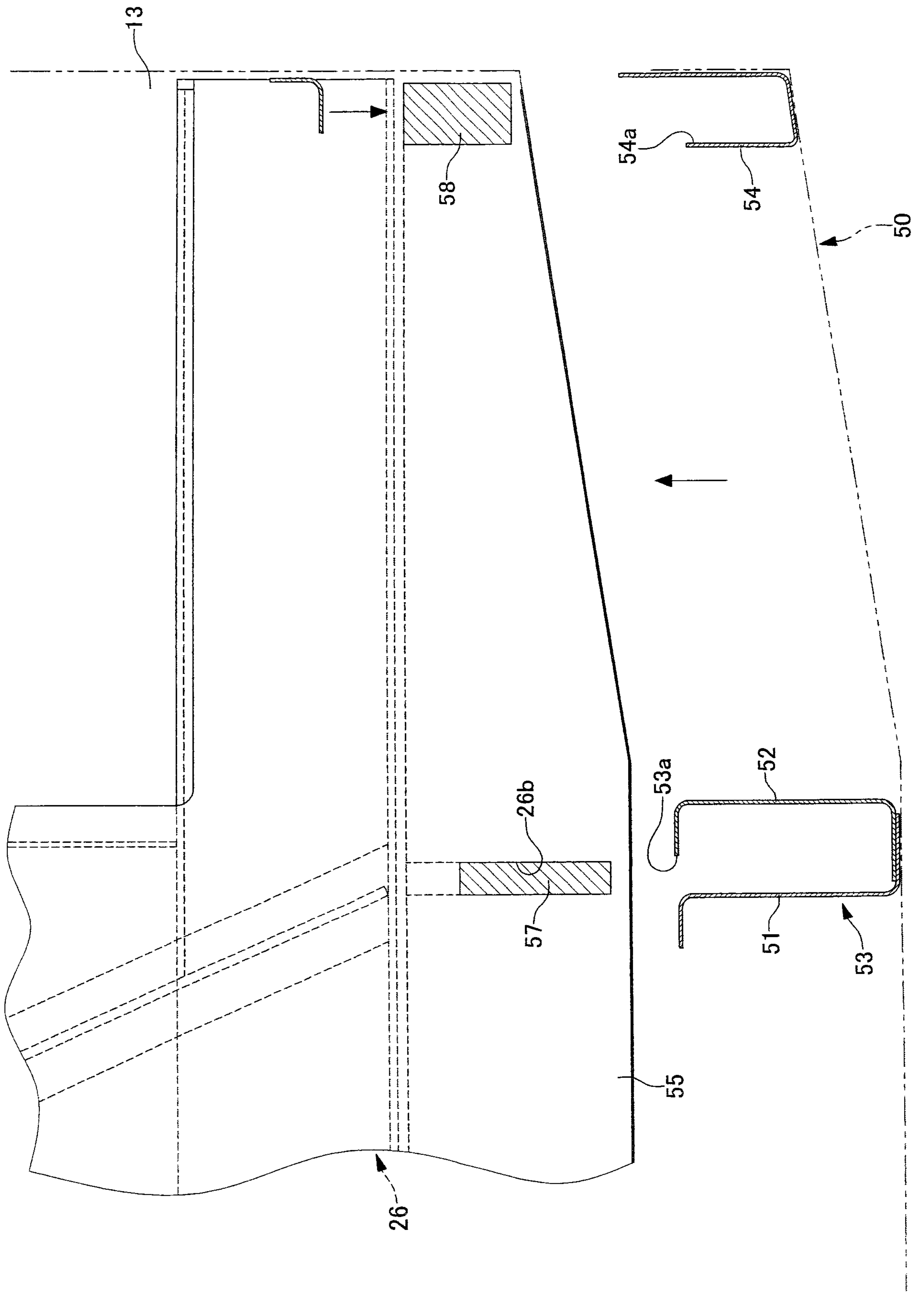

FIG.11

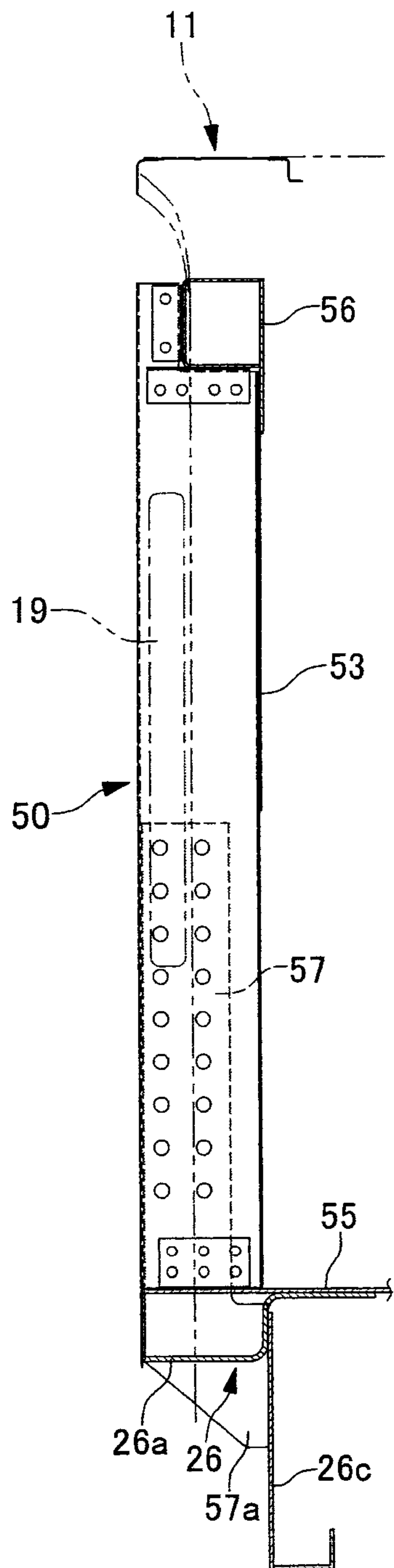

FIG.12

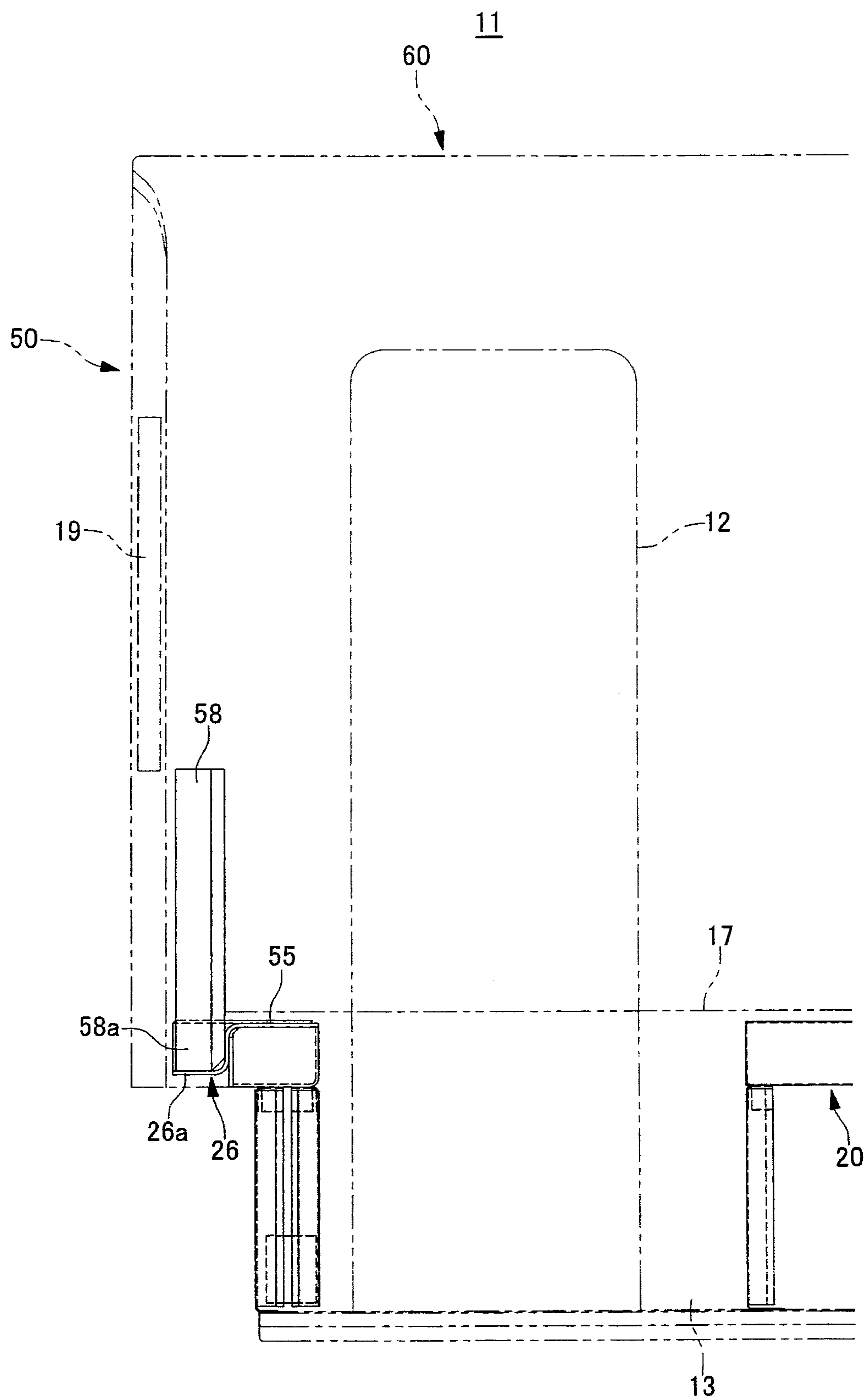

FIG.13

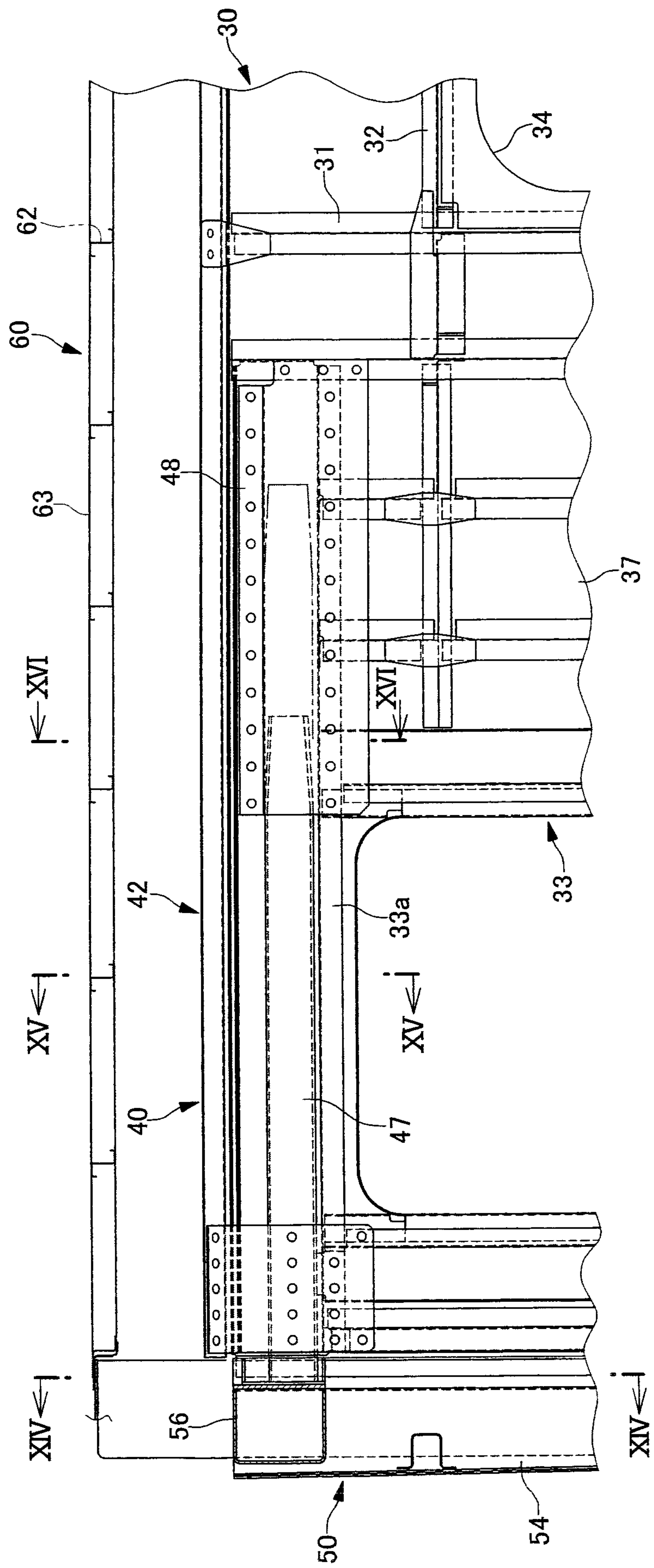

FIG.14

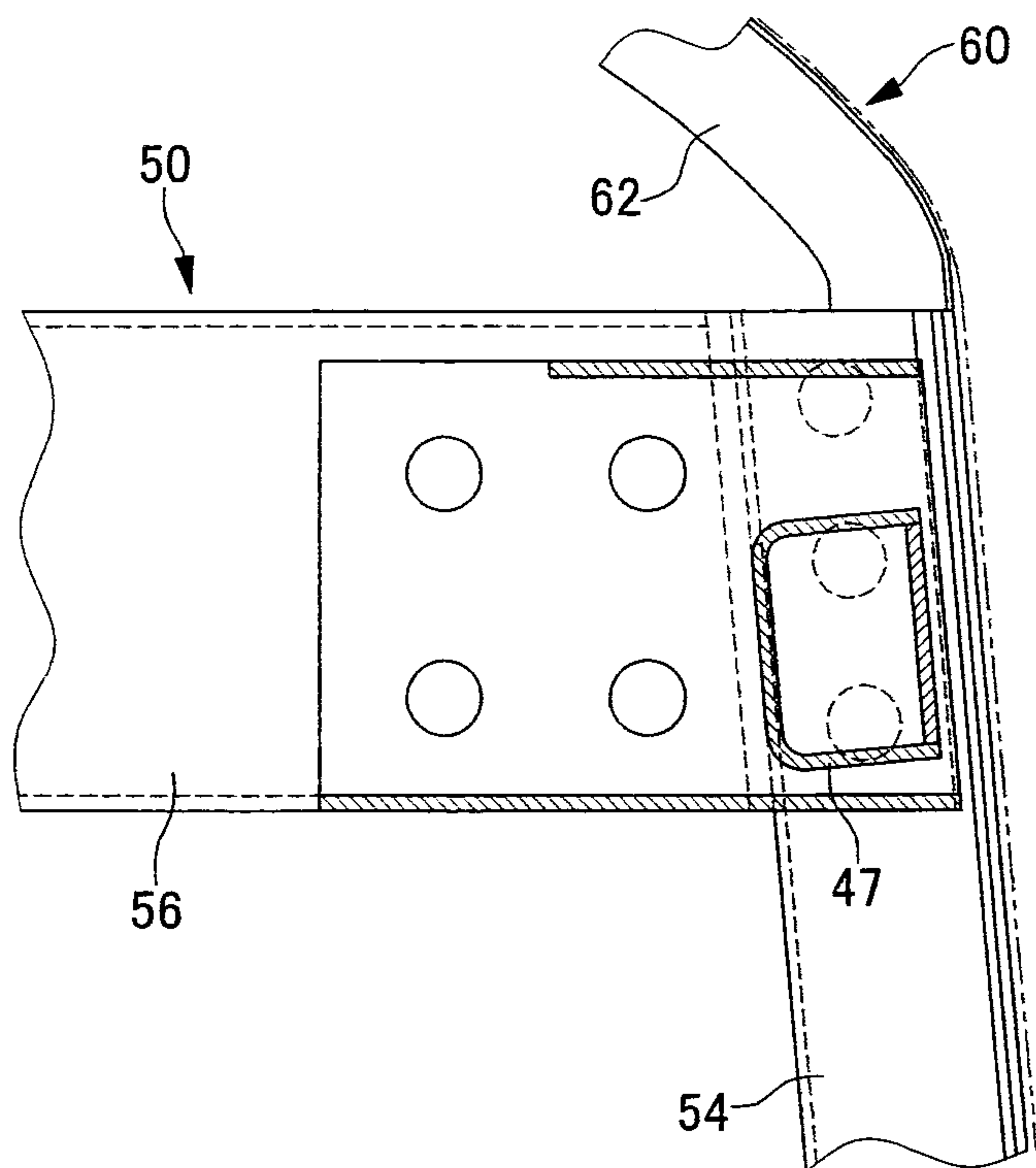

FIG.15

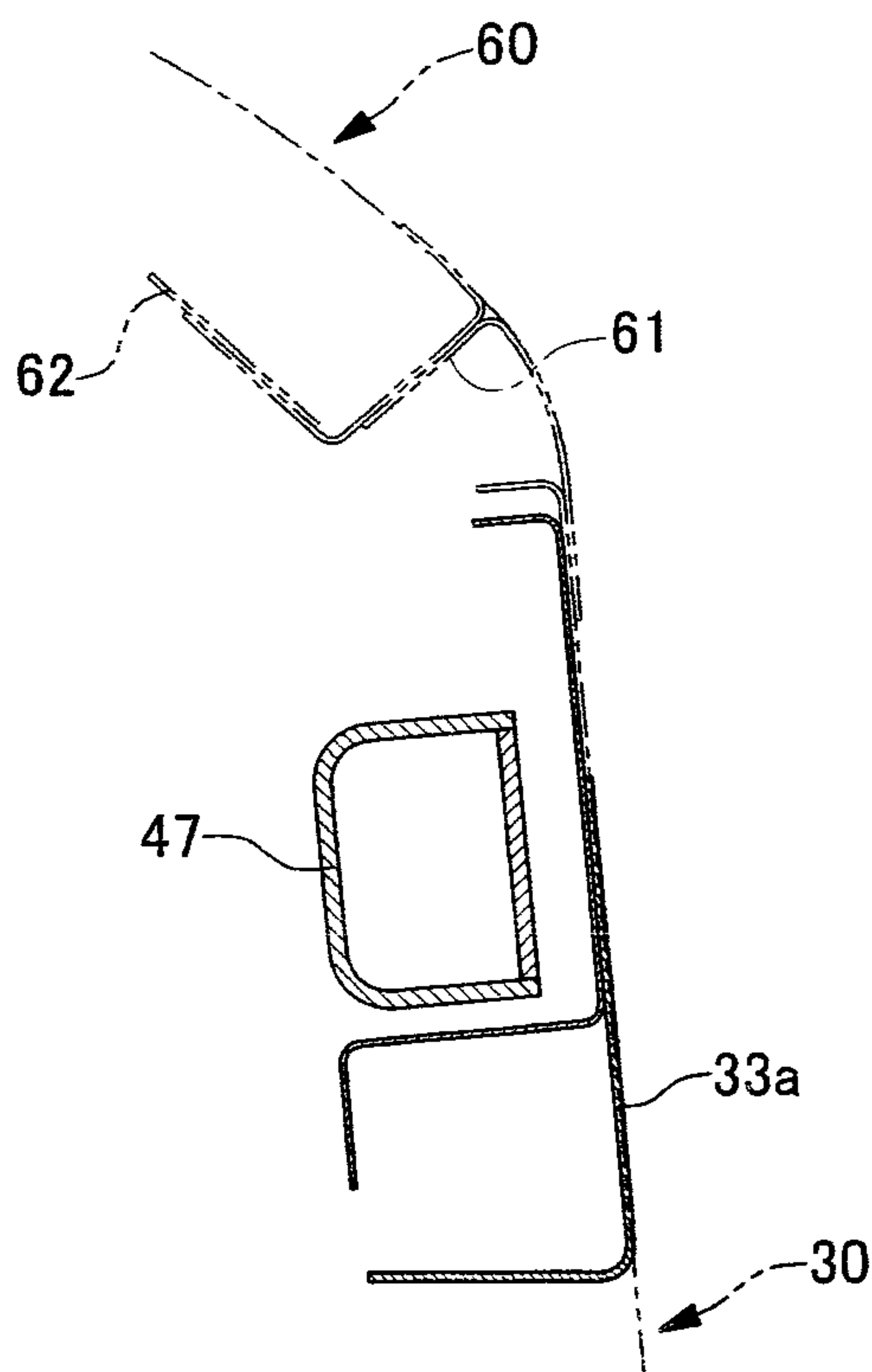

FIG.16

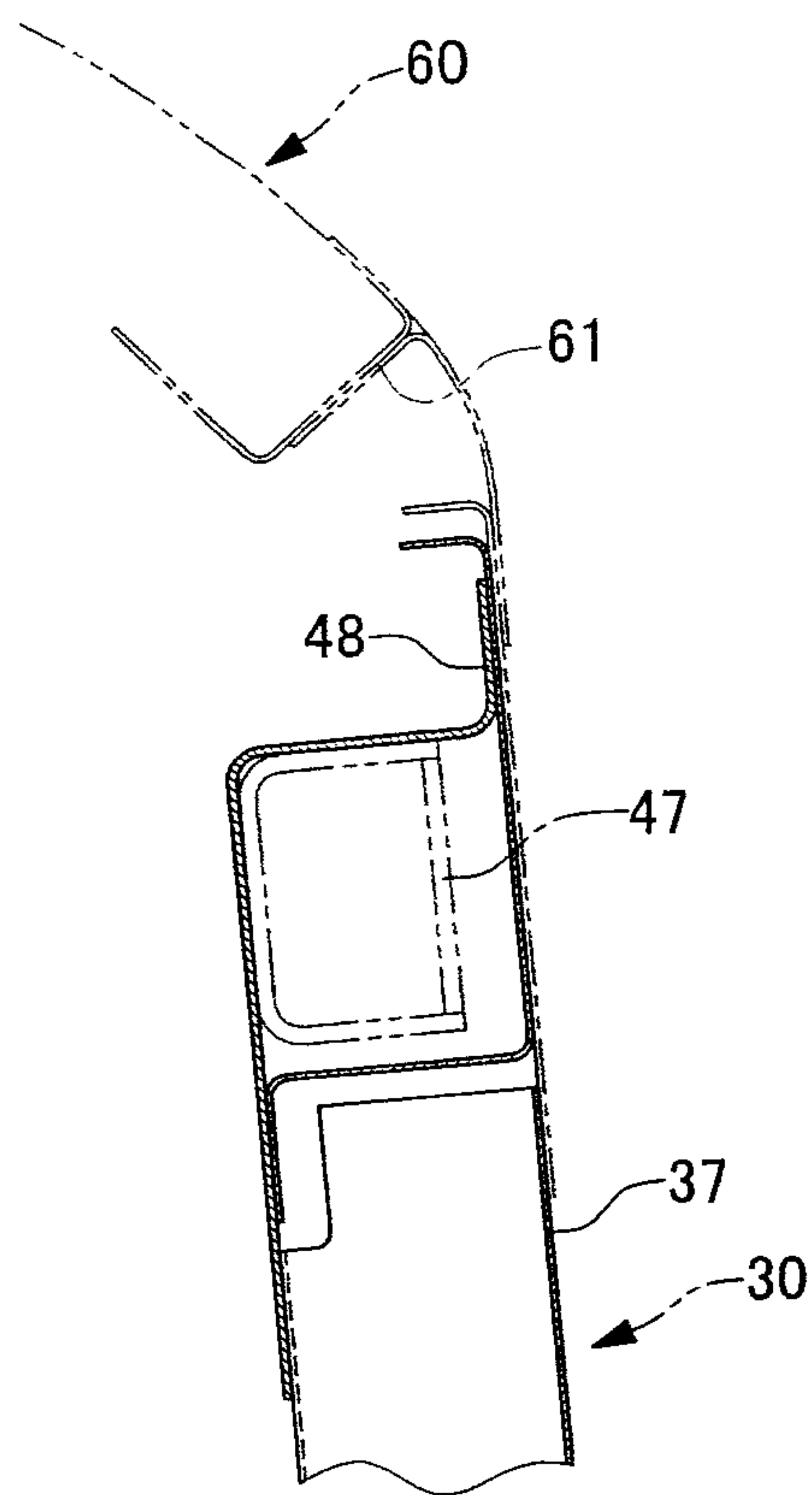

FIG.17

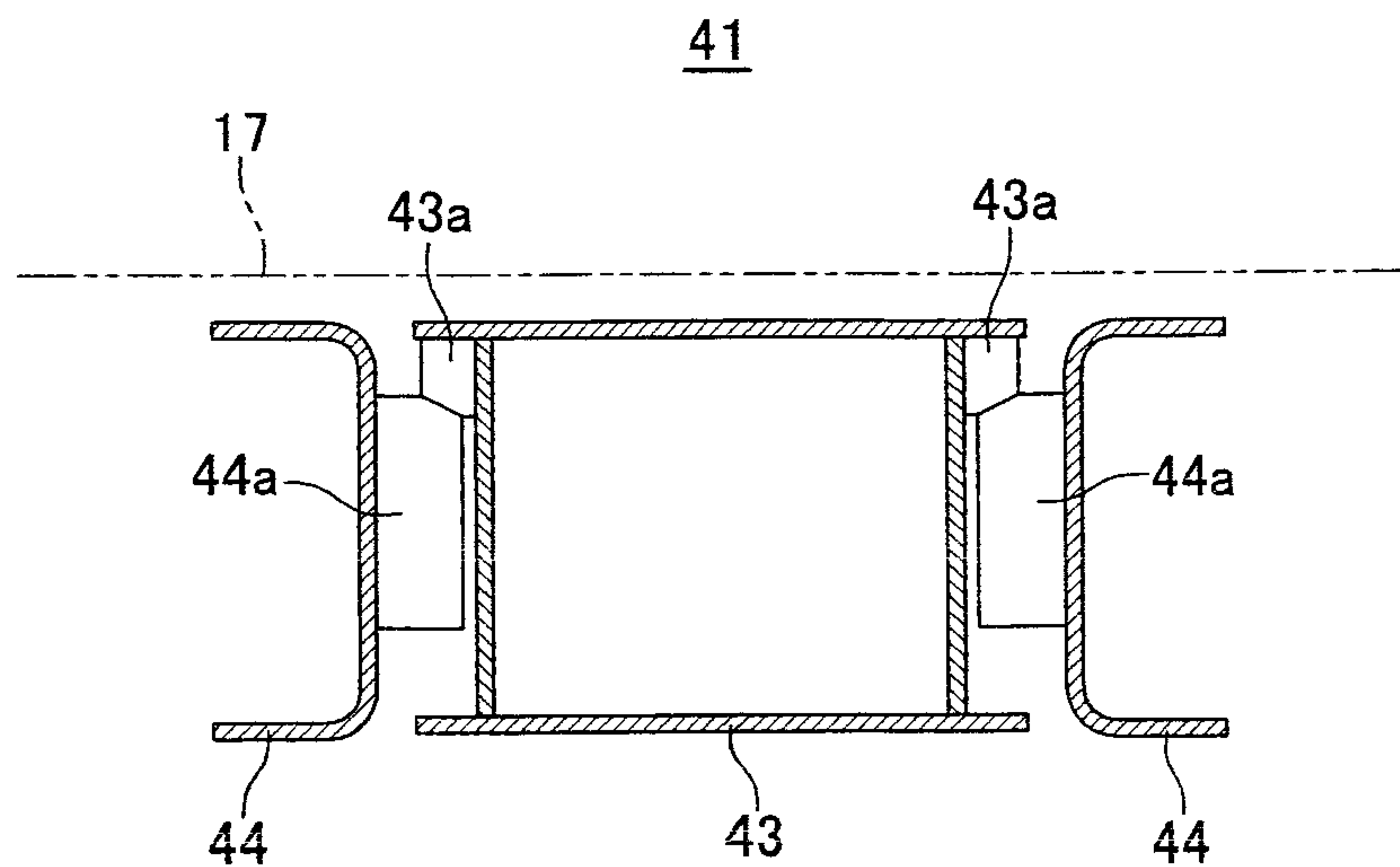

FIG.19

11

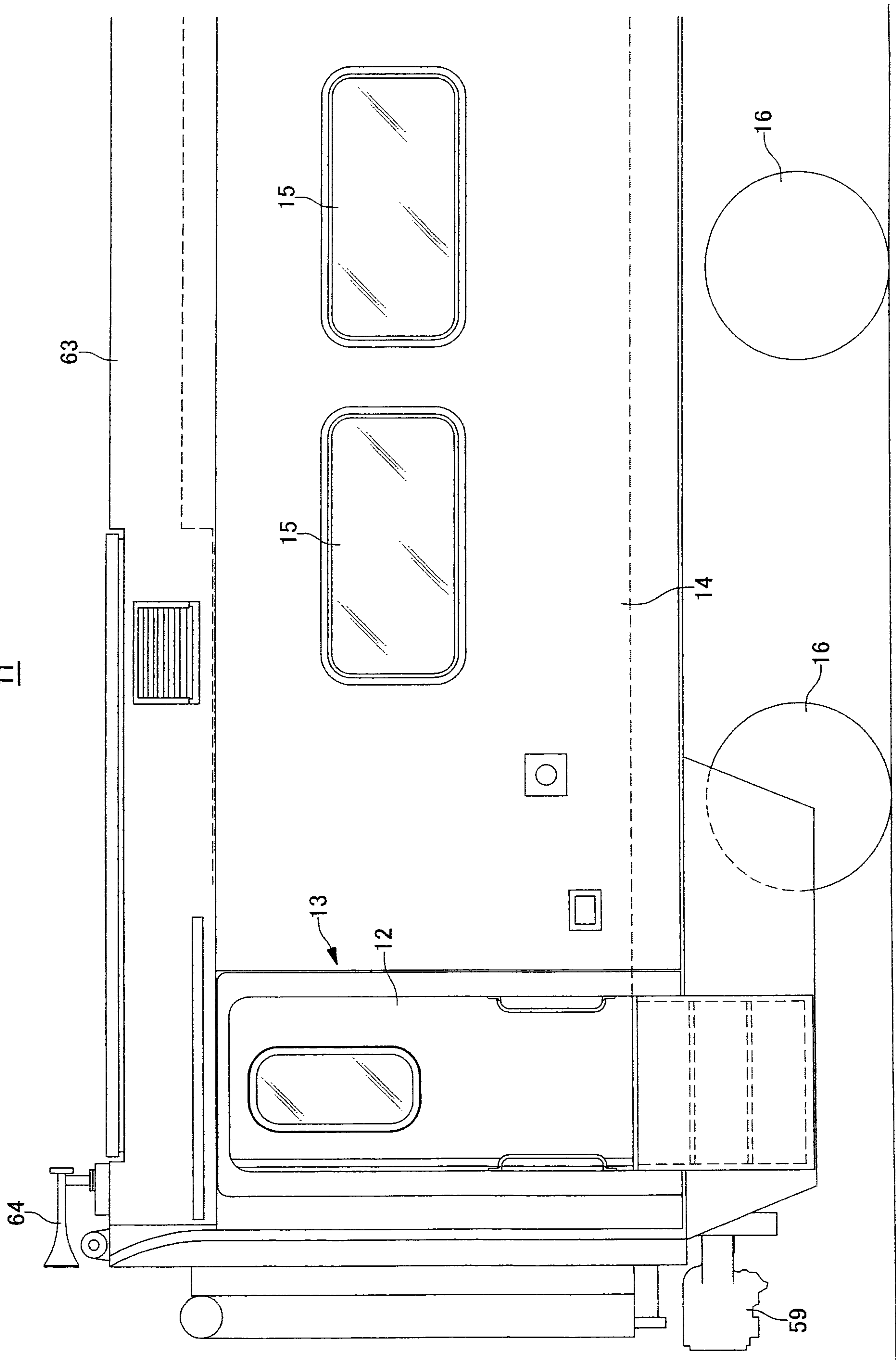

FIG.20

