



INTERNATIONAL APPLICATION PUBLISHED UNDER THE PATENT COOPERATION TREATY (PCT)

<p>(51) International Patent Classification ⁷ : B22C 11/10</p>	<p>A1</p>	<p>(11) International Publication Number: WO 00/50187 (43) International Publication Date: 31 August 2000 (31.08.00)</p>
<p>(21) International Application Number: PCT/DK99/00077 (22) International Filing Date: 23 February 1999 (23.02.99) (71) Applicant (for all designated States except US): GEORG FISCHER DISA A/S [DK/DK]; Herlev Hovedgade 17, DK-2730 Herlev (DK). (72) Inventor; and (75) Inventor/Applicant (for US only): KNUDSEN, Søren, Erik [DK/DK]; Bundsvej 53, DK-3500 Værløse (DK). (74) Agent: BUDDE, SCHOU & OSTENFELD A/S; Vestergade 31, DK-1456 København K (DK).</p>	<p>(81) Designated States: AL, AM, AT, AU, AZ, BA, BB, BG, BR, BY, CA, CH, CN, CU, CZ, DE, DK, EE, ES, FI, GB, GD, GE, GH, GM, HR, HU, ID, IL, IN, IS, JP, KE, KG, KP, KR, KZ, LC, LK, LR, LS, LT, LU, LV, MD, MG, MK, MN, MW, MX, NO, NZ, PL, PT, RO, RU, SD, SE, SG, SI, SK, SL, TJ, TM, TR, TT, UA, UG, US, UZ, VN, YU, ZW, ARIPO patent (GH, GM, KE, LS, MW, SD, SZ, UG, ZW), Eurasian patent (AM, AZ, BY, KG, KZ, MD, RU, TJ, TM), European patent (AT, BE, CH, CY, DE, DK, ES, FI, FR, GB, GR, IE, IT, LU, MC, NL, PT, SE), OAPI patent (BF, BJ, CF, CG, CI, CM, GA, GN, GW, ML, MR, NE, SN, TD, TG).</p> <p>Published With international search report.</p>	

(54) Title: MACHINE FOR PRODUCING FLASKLESS MOULDS

(57) Abstract

A moulding machine for producing flaskless moulds is provided with at least a cope flask (3) and a drag flask (4) and a pattern plate (15) therebetween. The pair of flasks (3, 4) is alternatively positioned in a horizontal position in which the produced moulds are removed and the pattern plate is inserted and removed, and in a vertical mould-forming position in which the sand is charged and compacted. According to the invention, the cope flask (3), the drag flask (4), the first squeeze plate (5), the second squeeze plate (6) are rotated in unison.

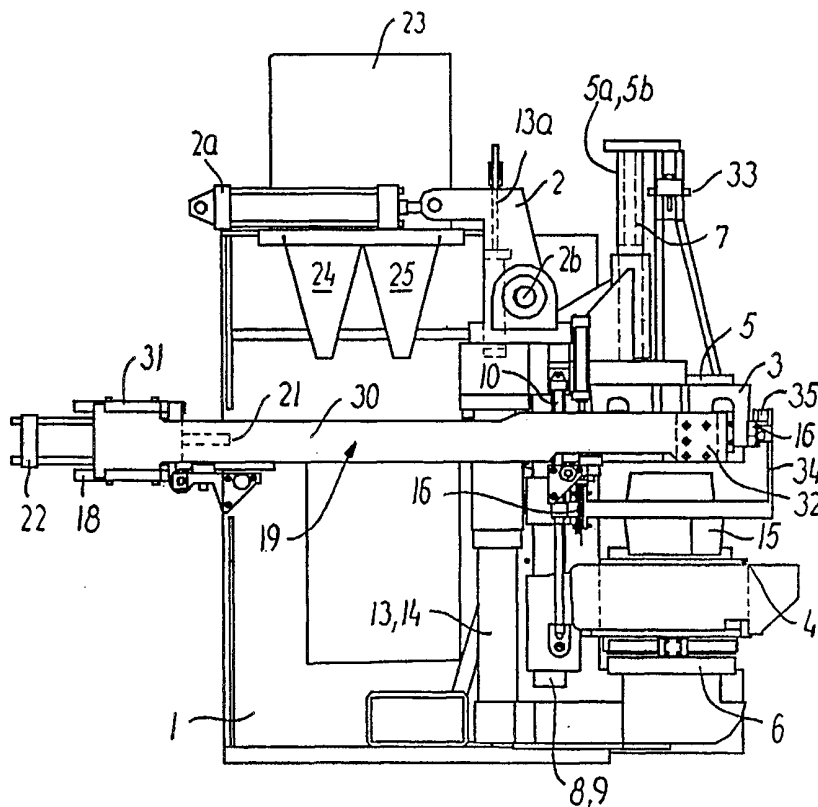

FOR THE PURPOSES OF INFORMATION ONLY

Codes used to identify States party to the PCT on the front pages of pamphlets publishing international applications under the PCT.

AL	Albania	ES	Spain	LS	Lesotho	SI	Slovenia
AM	Armenia	FI	Finland	LT	Lithuania	SK	Slovakia
AT	Austria	FR	France	LU	Luxembourg	SN	Senegal
AU	Australia	GA	Gabon	LV	Latvia	SZ	Swaziland
AZ	Azerbaijan	GB	United Kingdom	MC	Monaco	TD	Chad
BA	Bosnia and Herzegovina	GE	Georgia	MD	Republic of Moldova	TG	Togo
BB	Barbados	GH	Ghana	MG	Madagascar	TJ	Tajikistan
BE	Belgium	GN	Guinea	MK	The former Yugoslav Republic of Macedonia	TM	Turkmenistan
BF	Burkina Faso	GR	Greece	ML	Mali	TR	Turkey
BG	Bulgaria	HU	Hungary	MN	Mongolia	TT	Trinidad and Tobago
BJ	Benin	IE	Ireland	MR	Mauritania	UA	Ukraine
BR	Brazil	IL	Israel	MW	Malawi	UG	Uganda
BY	Belarus	IS	Iceland	MX	Mexico	US	United States of America
CA	Canada	IT	Italy	NE	Niger	UZ	Uzbekistan
CF	Central African Republic	JP	Japan	NL	Netherlands	VN	Viet Nam
CG	Congo	KE	Kenya	NO	Norway	YU	Yugoslavia
CH	Switzerland	KG	Kyrgyzstan	NZ	New Zealand	ZW	Zimbabwe
CI	Côte d'Ivoire	KP	Democratic People's Republic of Korea	PL	Poland		
CM	Cameroon	KR	Republic of Korea	PT	Portugal		
CN	China	KZ	Kazakstan	RO	Romania		
CU	Cuba	LC	Saint Lucia	RU	Russian Federation		
CZ	Czech Republic	LI	Liechtenstein	SD	Sudan		
DE	Germany	LK	Sri Lanka	SE	Sweden		
DK	Denmark	LR	Liberia	SG	Singapore		
EE	Estonia						

MACHINE FOR PRODUCING FLASKLESS MOULDS

TECHNICAL FIELD

5

The present invention relates to a machine for producing flaskless moulds of the kind set forth in the preamble of claim 1.

BACKGROUND ART

15

Document EP-0,468,355 discloses a conventional moulding forming machine of the above-mentioned type. This moulding machine is of a type in which a cope flask, a pattern plate and a drag flask are capable of rotating over an angle of 90° between a horizontal position and a vertical position. The horizontal position is associated with inserting the pattern plate between the cope- and drag flask before the sand charging and compacting step and is associated with the removing of the pattern plate and the discharging of the cope and drag after the charging and compacting step. The sand charging and compacting step is performed with the cope flask, drag flask and pattern plate in the vertical position. The prior art moulding machine uses a first squeeze plate for compacting the sand in the cope flask (the upper flask by definition) and a second squeeze plate for compacting the sand in the drag flask (the lower flask by definition). The second squeeze plate is inserted into the drag flask when the latter is in the vertical position. Because of the rotating movement of the drag flask with respect to the fixed second squeeze plate, it is difficult to align the drag flask with the second squeeze plate in a precise and reproducible manner. The exact alignment in the prior art machine has to be carried out by the compression frame, which has already another important function, namely the transmission of the force for compacting the sand from one squeeze plate to the other. Therefore, the above described second squeeze plate cannot always be smoothly introduced into the drag flask due to deviations in the alignment of the two components.

20
25
30

DISCLOSURE OF THE INVENTION

It is the object of the present invention to provide a moulding machine for producing flaskless moulds of the kind referred to above, with which it is possible to overcome
5 the disadvantages mentioned above and which allows easier alignment of the second squeeze plate with the drag flask, thus resulting in a simpler construction of the components of the machine and in higher quality drags and copes. This object is achieved with a machine for producing flaskless moulds of said kind, which according to the present invention also comprises the features set forth in the
10 characterizing clause of claim 1. With this arrangement, the alignment function of the compression frame is transferred to a swing frame which takes care of all alignment, whereas the compression frame is only constructed to transmit the relatively large forces related to the compacting of the sand. Thus, the second squeeze plate is always kept in alignment, avoiding problems associated with
15 reproducibility of position. The lower and upper squeeze plate as well as the drag- and cope flask are rotated over approximately 90° to take their vertical position in which the cope flask and drag flask are filled with sand. After the sand-filling, the compacting of the sand also takes place in the vertical position.

20 According to a further embodiment, the swing frame which carries the squeeze plates and the flasks is received in an opening in the compression frame.

According to another embodiment of the invention, the drag flask is arranged to be movable up and down with respect to the fixed cope flask when the cope flask and
25 drag flask are in their horizontal position.

According to yet another embodiment of the invention, the first squeeze plate and the second squeeze plate are supported by a swing frame.

30 In an embodiment of the present invention, the second squeeze plate is inserted in the drag flask when the cope flask and drag flask are in their horizontal position.

According to a further embodiment, the second squeeze plate serves as a table to receive and lower the superposed cope and drag when the latter are discharged

from the cope flask and drag flask, thus doing away with the need for an additional transport table.

5 According to a further embodiment, the sand-charging openings of the respective cope flask and drag flask will, when the latter are moved into their vertical position, engage the sand-blowing nozzles of the blowhead.

BRIEF DESCRIPTION OF THE DRAWINGS

10

In the following detailed part of the present description, the invention will be explained in more detail with reference to the exemplary embodiments of the machine for producing flaskless moulds according to the invention shown in the drawings, in which

15

Figure 1 shows a view of the moulding machine from the side in a state just before a mould-forming operation,

Figure 2 shows the machine in the same state from the front,

Figure 3 shows the state in which the pattern plate has been inserted into the machine,

20

Figure 4 shows the machine in a state in which the mould flasks are brought together with the pattern plate in between them,

Figure 4.1 shows the machine in the same state as in Figure 4 from the side,

Figure 5 shows the machine in a side view, with the flasks and squeeze plate arrangement rotated into the vertical position and the flasks being filled with sand,

25

Figure 6 shows the next state in which the sand is being compacted,

Figure 7 shows the flasks containing compacted sand returned in the horizontal position,

Figure 8 shows a view from the side as in Figure 2, but with the drag flask lowered in order to allow the pattern plate to be taken out of the moulding machine,

30

Figure 9 shows the next state in which the flasks with the cope and drag are brought together again without the pattern plate between them in order to allow for the now superposed cope and drag to be ejected from the flasks, and

Figure 10 shows the machine in a state in which the superposed cope and drag are placed on the lower squeeze plate which has been lowered so that the finished mould can be ejected on to a conveying means next to the moulding machine.

5

DESCRIPTION OF THE PREFERRED EMBODIMENTS

Figure 1-10 elucidate the steps which are carried out by the machine according to the invention in order to produce a flaskless mould. Figures 1, 5 and 6 are side views of the machine, whereas for practical reasons Figures 2-4 and 7-9 are front views of the machine according to the invention. The moulding machine shown in Figure 1 is provided with a base frame 1 which carries the other components of the machine. A swing frame 2 is rotatably mounted to the base frame 1 through a shaft 2b. The swing frame can be rotated by an actuator 2a. The actuator 2a is preferably a hydraulic cylinder fastened to the base frame 1 at one of its lateral ends and with its piston rod fastened to the swing frame 2 at a suitable distance from the shaft 2b.. The swing frame 2 supports the cope flask 3 and drag flask 4 as well as the first squeeze plate 5 and second squeeze plate 6. The cope flask 3 is fixed on the swing frame 2. The first squeeze plate 5 is suspended by two guide rods 5a, 5b from the swing frame 2 by a linear bearing which allows a relative movement of the first squeeze plate 5 with respect to the cope flask 3. The upper ends of the guide rods 5a, 5b are connected to one another by a bracket 33. A first linear actuator 7, preferably a hydraulic actuator, is secured at one of its ends to the swing frame 2 and at its other end to the bracket 33 so that the first squeeze plate may be moved up and down. The first squeeze plate 5 is movably fitted in the cope flask 3.

A drag flask 4 is disposed below the cope flask 3. The drag flask 4 is suspended from the swing frame 2 by a pair of guide rods 8, 9 to allow a linear movement with respect to the latter. The guide rods 8, 9 are connected at one of their lateral ends to the swing frame and their opposite lateral ends are inserted into linear bearings in the drag flask 4. Two second linear actuators 10 are fastened with one end to the drag flask 4 and at the opposite end to the swing frame 2. Thus, the drag flask 4 can be moved up and down by the second actuators in order to move the drag flask 4 towards and away from the cope flask 3.

The cope flask 3 and the drag flask 4 define on their right-side wall ("right" as in Figure 1) sand-charging openings 11, 12. The sand-charging openings are placed such that they abut with sand-blowing nozzles 24, 25, when the cope flask 3 and the drag flask 4 are rotated to the vertical position.

5

The second squeeze plate 6 is movably fitted within the drag flask 4. The second squeeze plate 6 is suspended from the swing frame by a second pair of guide rods 13, 14 which are inserted in linear bearings in the swing frame 2. One third actuator 13a, preferably in the form of a hydraulic cylinder which may also provide for the linear bearing function, is fastened on one of its ends to the swing frame 2 and at its
10 opposite end to the second squeeze plate 6 for allowing movement up and down of the squeeze plate 6.

A pattern plate 15 is suspended from the swing frame 2 in order to allow a
15 horizontal translative movement of the pattern plate 15 in and out of the space between the flasks (Figure 2). The pattern plate carrier 15a has suspending members 34 at two corners thereof, each of the suspending members having a roller 35 at the top portion thereof, and two rollers 35 are attached to the remaining two corners of the carrier plate 15a. Both the cope flask 3 and the rotatable frame 2
20 have on the front surface thereof, a rail 16 disposed horizontally to correspond to the rollers 35. A fourth actuator 17 secured at one of its ends to the cope flask and at its opposite end to the pattern plate carrier allows movement of the pattern plate in and out of the moulding machine.

25 A compression frame 18, carried by the base frame 1, extends horizontally. The compression frame 18 is suspended from the base frame so as to allow a horizontal translative movement in order to allow equalisation of the force exercised on the first squeeze plate 5 to the second squeeze plate 6. The compression frame 18 comprises a tie 30 arranged horizontally, longitudinally and laterally disposed on
30 each side of the rotatable frame. The ties 30 are guided so as to allow the above-mentioned horizontal translative movement. The ties 30 are connected to each other at one of their lateral end portions by a connection bar 31. Thus, the compression frame 18 defines an opening 19 between the two ties which is large enough to receive the rotatable frame 2 together with the drag flask 4 and the cope

flask 3 in both the vertical and the horizontal position. A fifth linear actuator 22, preferably a hydraulic cylinder having a piston rod 21, is fastened to the connection bar 31. The second squeeze plate 6 is moved towards the pattern plate 15 by the force of the hydraulic cylinder 22 by the piston rod 21 engaging the second squeeze plate 6. The compression frame 18 transmits this force through the ties to its other lateral end which is open, i.e. the other lateral ends of the ties 30 are not connected to one another. These lateral ends of the ties 30 are provided with abutment plates 32 which extend towards one another. The abutment plates 32 engage with the bracket 33 for transmitting the compression force to the first squeeze plate 5.

10

A blowhead 23 with a sand-inlet part at its top and two sand-blowing nozzles 24, 25 at its lower side is attached to the base frame 1 in a position so that the sand-blowing nozzles 24,25 will engage the respective sand-charging openings 11, 12 of the drag flask 4 and cope flask 3 when the latter are in their vertical position.

15

The production process of moulding a flaskless mould comprising two mould halves with the machine according to the invention will now be described with reference to Figures 1-10. The sequence of operation starts in the state shown in Figures 1 and 2, with the flasks in a horizontal position and with the drag flask lowered to its lowermost position. Next, the pattern plate 15 is displaced laterally into the space between the cope flask 3 and the drag flask 4 (Figure 3). The drag flask 4 and the second squeeze plate 6 are moved upwards towards the cope flask 3 by the second actuator 10 and the third actuators 13a, respectively, thereby clamping the pattern plate 15 between the cope flask 3 and the drag flask 4. In this state, the first squeeze plate 5, is inserted into the cope flask 3, the second squeeze plate 6 is inserted into the drag flask 4, and these components are all in alignment (Figure 4).

In the next step, the swing frame is rotated over 90° from the horizontal position to the vertical position by the hydraulic cylinder 2a, as shown in Figure 5. The sand-blowing nozzles 24,25 of the blowhead 23 now abut with the sand-charging openings 11, 12 of the respective flask. In the following step, the mould-half forming spaces in the cope flask 3 and the drag flask 4 are filled with sand by supplying compressed air into the blowhead 23.

30

Thereafter, the charged sand is compacted by the first pressure plate 5 and second pressure plate 6 being forced further into the cope flask 3 and drag flask 4, respectively. Hereto the fifth actuator 22 which is fastened to the right-side
5 compression frame 18 and the piston rod 21 is actuated so that the piston rod 21 forces the second squeeze plate 6 into the drag flask 4. The force thus exercised on the drag flask is transmitted through the compression frame to the first squeeze plate via the abutment plates 32 and the bracket 33. Since the compression frame 18 is horizontally suspended so that it can move longitudinally, the force exercised
10 on the pressure plates is equalised (Figure 6). As a result, a cope 26 and a drag 27 are moulded by compression in the cope flask 3 and the drag flask 4.

After a predetermined time interval, in which the squeezing is completed, as a next step, the swing frame 2 is rotated over 90° back from the vertical position to its
15 starting position, in which the cope flask 3 and drag flask 4 take their horizontal position (Figure 7).

In a further step, the drag flask 4 and the lower squeeze plate 6 are lowered in unison and the pattern plate 15 is lowered to take its position in between the cope
20 flask 3 and the drag flask 4 (Figure 8), causing the pattern plate 15 to separate from the cope flask 3 by being lowered while resting on the drag flask until the rollers 35 of the suspending member 34 engage the rails 16. Next, the pattern plate 15 is retracted from the space between the cope flask 3 and the drag flask 4 by the hydraulic cylinder 17 to take its position as shown in Figure 2. The drag flask 4 and
25 the second squeeze plate 6 are raised in unison until the upper surface of the drag flask 4 is in contact with the lower surface of the cope flask 3, causing the mould surface of the cope to be brought into contact with the mould surface of the drag. Thus, the cope 26 and the drag 27 are superposed (Figure 9).

30 Thereafter, the first squeeze plate 5 is lowered by the first actuator 7 to separate the cope 26 and drag 27 from the cope flask 3 and drag flask 4. The second squeeze plate 6 is simultaneously lowered and serves as a table for the superposed cope 26 and drag 27 and transports the cope 26 and drag 27 downwards to a position in which the superposed cope 26 and drag 27 can be expelled from the moulding

machine (Figure 10). In the following step, a sixth actuator 28 pushes the superposed cope 26 and drag 27 from the lowered second squeeze plate 6 on to a conveyor means 29 adjacent to the moulding machine.

- 5 The machine has reached its starting position again and is ready for producing the next mould, as part of a cycle operation which is repeated for mass production of flaskless moulds.

10 Although the above described embodiment is illustrated with a fixed cope flask 3 and a movable drag flask 4, the cope flask 3 may instead be arranged movable and the drag flask 4 may be arranged fixed to the swing frame 2.

LIST OF REFERENCE NUMERALS

	1	base frame
	2	swing frame
5	2a	actuator
	2b	shaft
	3	cope flask
	4	drag flask
	5	first squeeze plate
10	6	second squeeze plate
	7	first actuator
	8	guide rod
	9	guide rod
	10	second actuator
15	11	sand-charging opening
	12	sand-charging opening
	13	guide rod
	13a	third actuator
	14	guide rod
20	15	pattern plate
	15a	pattern plate carrier
	16	rail
	17	fourth actuator
	18	compression frame
25	19	opening
	21	piston rod
	22	fifth linear actuator
	23	blowhead
	24	sand-blowing nozzle
30	25	sand-blowing nozzle
	26	cope
	27	drag
	28	sixth actuator

- 29 conveyor means
- 30 tie
- 31 connection bar
- 32 abutment plates
- 5 33 bracket
- 34 suspending member
- 35 roller

CLAIMS

1. A moulding machine for producing flaskless moulds comprising:
- a drag flask (4) and a cope flask (3) arranged to be rotated between a horizontal
5 position and a vertical position and arranged to be movable relatively towards one
another and away from one another in the horizontal position of said drag flask (4)
and cope flask (3),
- a first squeeze plate (5) inserted in the cope flask (3), and
- a second squeeze plate (6) associated with the drag flask (4),
10 characterised in that
the first squeeze plate (5) and the second squeeze plate (6) are rotatable in unison
with the drag flask (3) and the cope flask (4) between the horizontal position and the
vertical position.
- 15 2. Moulding machine according to claim 1, characterised in that the second
squeeze plate (6) is inserted into the drag flask (4) when the cope flask (3) and drag
flask (4) are rotated between the horizontal and the vertical position.
3. Moulding machine according to claim 1 or 2, characterised in that the drag
20 flask (4) is arranged to be movable up and down with respect to the cope flask (3)
when the cope flask (3) and drag flask (4) are in the horizontal position.
4. Moulding machine according to any of claims 1 to 3, characterised in that the
first squeeze plate (5) and the second squeeze plate (6) are supported by a swing
25 frame 2.
5. Moulding machine according to any of claims 1-4, characterised in that the
cope flask (3) and drag flask (4) are supported by the swing frame 2.
- 30 6. Moulding machine according to any of claims 1-5, characterised in that the
second squeeze plate (6) serves as a table to receive and lower the superposed
cope (26) and drag (27) when the latter are discharged from the cope flask (3) and
drag flask (4).

7. Moulding machine according to any one of the claims 1-6, characterised by comprising an actuator (13a) for positioning and moving the second squeeze plate (6) up and down when the cope flask (3) and the drag flask (4) are in the horizontal position.
- 5
8. Moulding machine according to claim 7, characterised in that the superposed cope (26) and drag (27) are discharged from the moulding machine by an actuator (30) pushing the superposed cope (26) and drag (27) from the lowered second squeeze plate (6), preferably on to a conveyor means (29).
- 10
9. Moulding machine according to any of the claims 1-8, characterised in that the drag flask (3) is suspended from the swing frame (2) so as to allow a relative movement with respect to the latter for moving the drag flask (4) to and from the cope flask (3).
- 15
10. Moulding machine according to any of the claims 1-9, characterised in that the second squeeze plate (6) is suspended from the swing frame (2) so as to allow a relative movement with respect to the latter for moving the second squeeze plate (6) towards and into the drag flask (4) and vice versa.
- 20
11. Moulding machine according to any of the claims 1-10, characterised by means associated with the swing frame for aligning the second squeeze plate with the drag flask.
- 25
12. Moulding machine according to any of the claims 1 to 11, characterised by further comprising a horizontally extending compression frame for transmitting the force applied on the squeeze plate (5, 6) to the other squeeze plate (5, 6).
- 30
13. Moulding machine according to claim 12, further comprising first drive means (22) arranged at one lateral end of the compression frame (18) for moving the second squeeze plate (6) and second drive means (32, 33) arranged at the opposite end of the compression frame (10) for moving the first squeeze plate (5).

14. Moulding machine according to claim 12 or 13, characterised by the drive means comprising a hydraulic cylinder (22) fastened to one lateral end of the compression frame (18), with the piston rod (21) of the hydraulic cylinder (22) being arranged for abutment with the second squeeze plate (6).

5

15. Moulding machine according to any of the claims 12-14, characterised in that the swing frame (2) is received in an opening (19) in the compression frame (18) when the flasks (3, 4) are in the vertical position.

10 16. Moulding machine according to any of the claims 1 to 15, characterised by further comprising means (17) for inserting a pattern plate (15) between the cope flask (3) and the drag flask (4).

15 17. Moulding machine according to any of the claims 1 to 16, characterised by the cope flask (3) and drag flask (4) having sand-charging openings (11, 12) in their respective side walls which form the top of the flasks (3, 4) when the flasks (3, 4) are in the vertical position.

20 18. Moulding machine according to any of the claims 1 to 17, characterised by further comprising a fixed blowhead (23) positioned so that the sand-blowing nozzles (24, 25) of the of the blowhead abut with the sand-charging opening (11, 12) of the respective flask (3, 4) that when the flasks (3, 4) are in the vertical position.

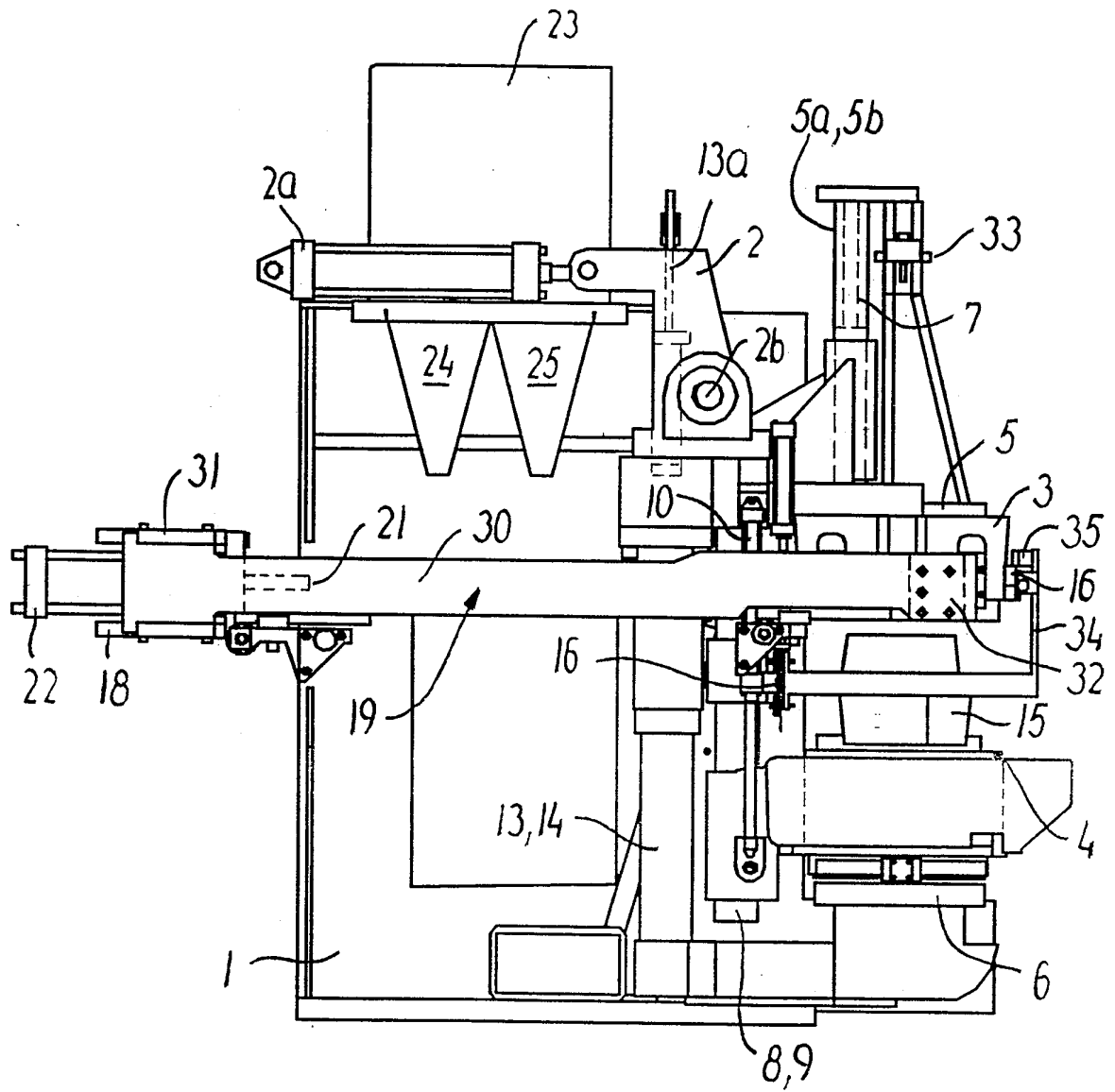

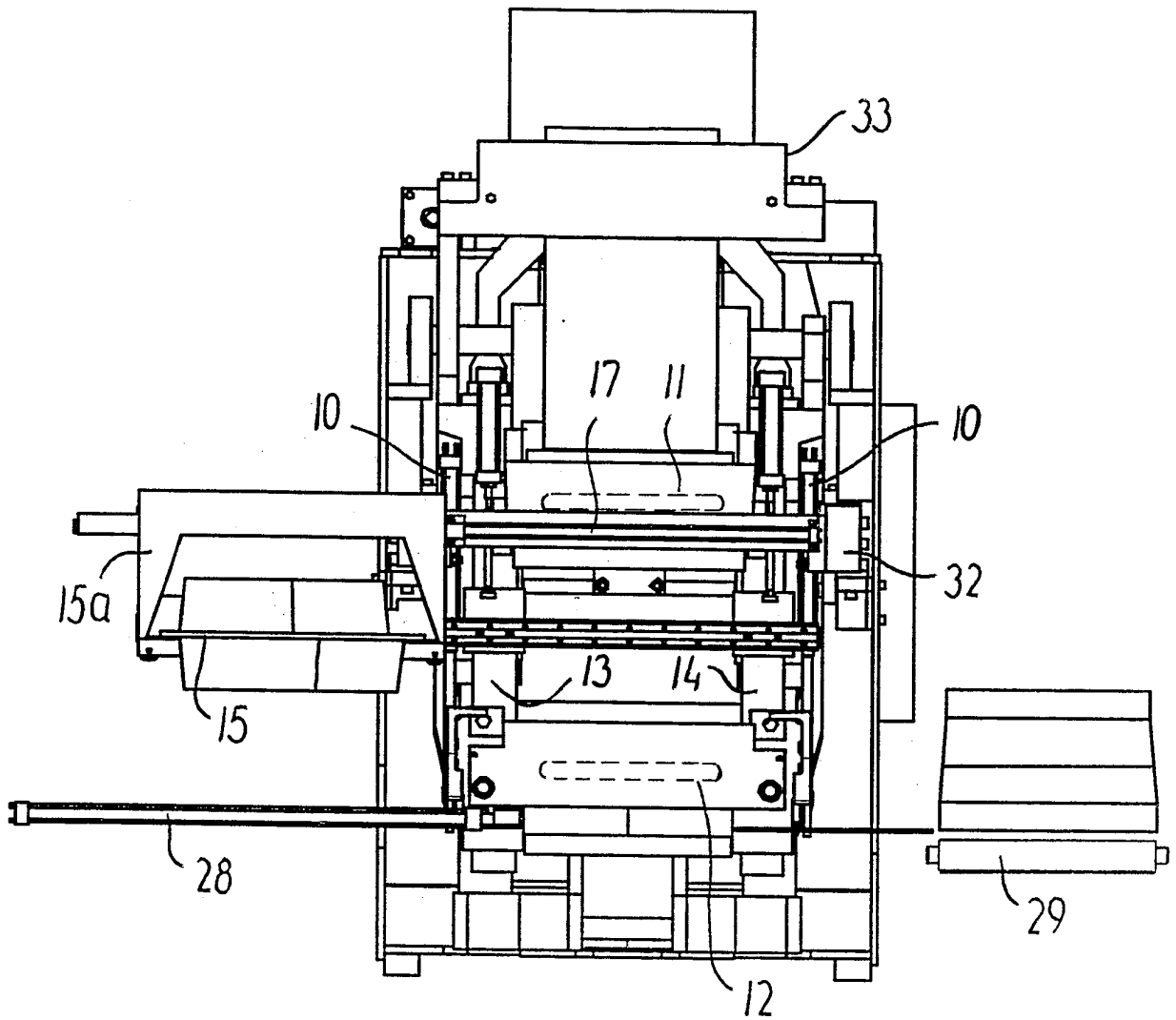

FIG. 2

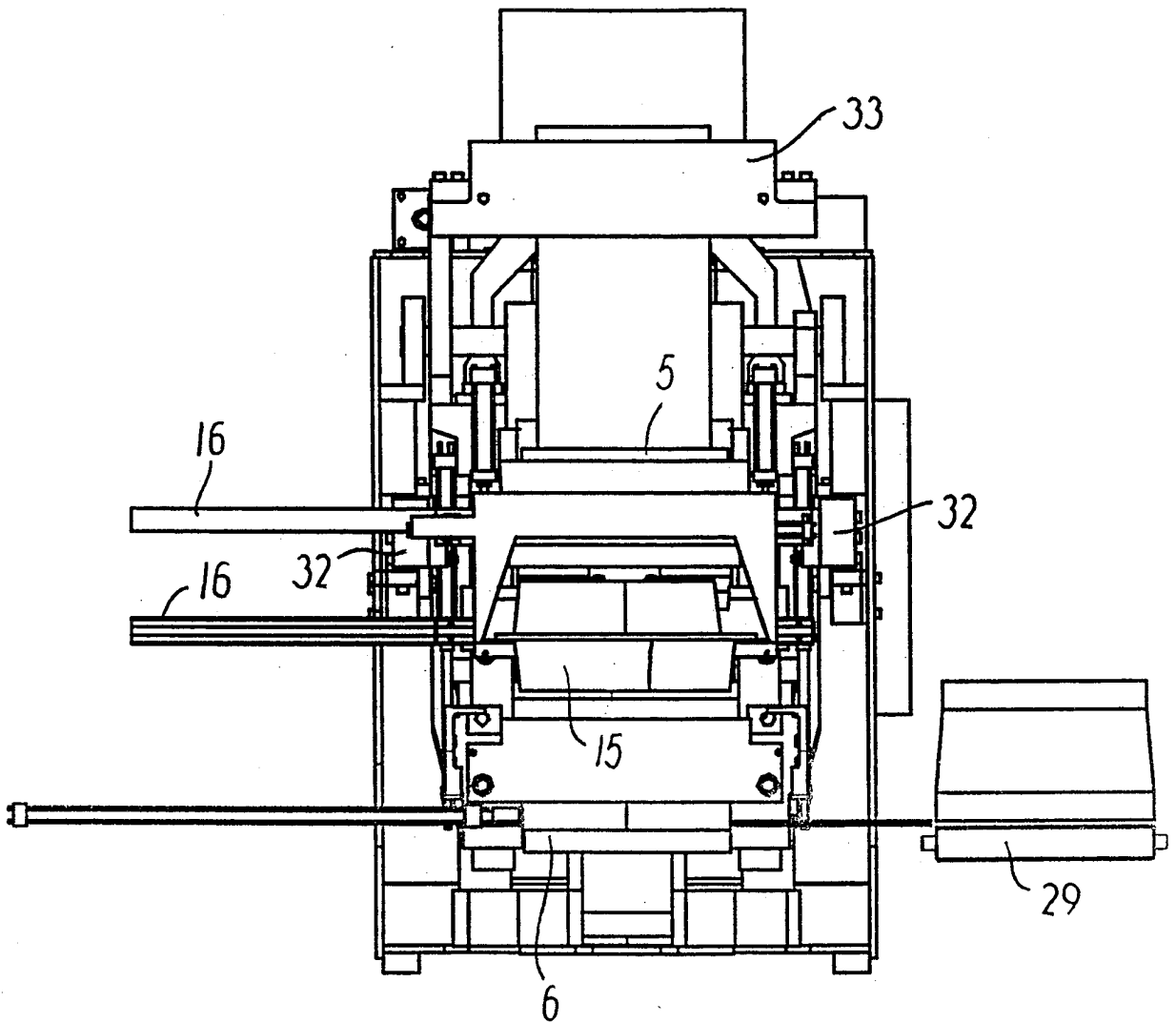

FIG. 3

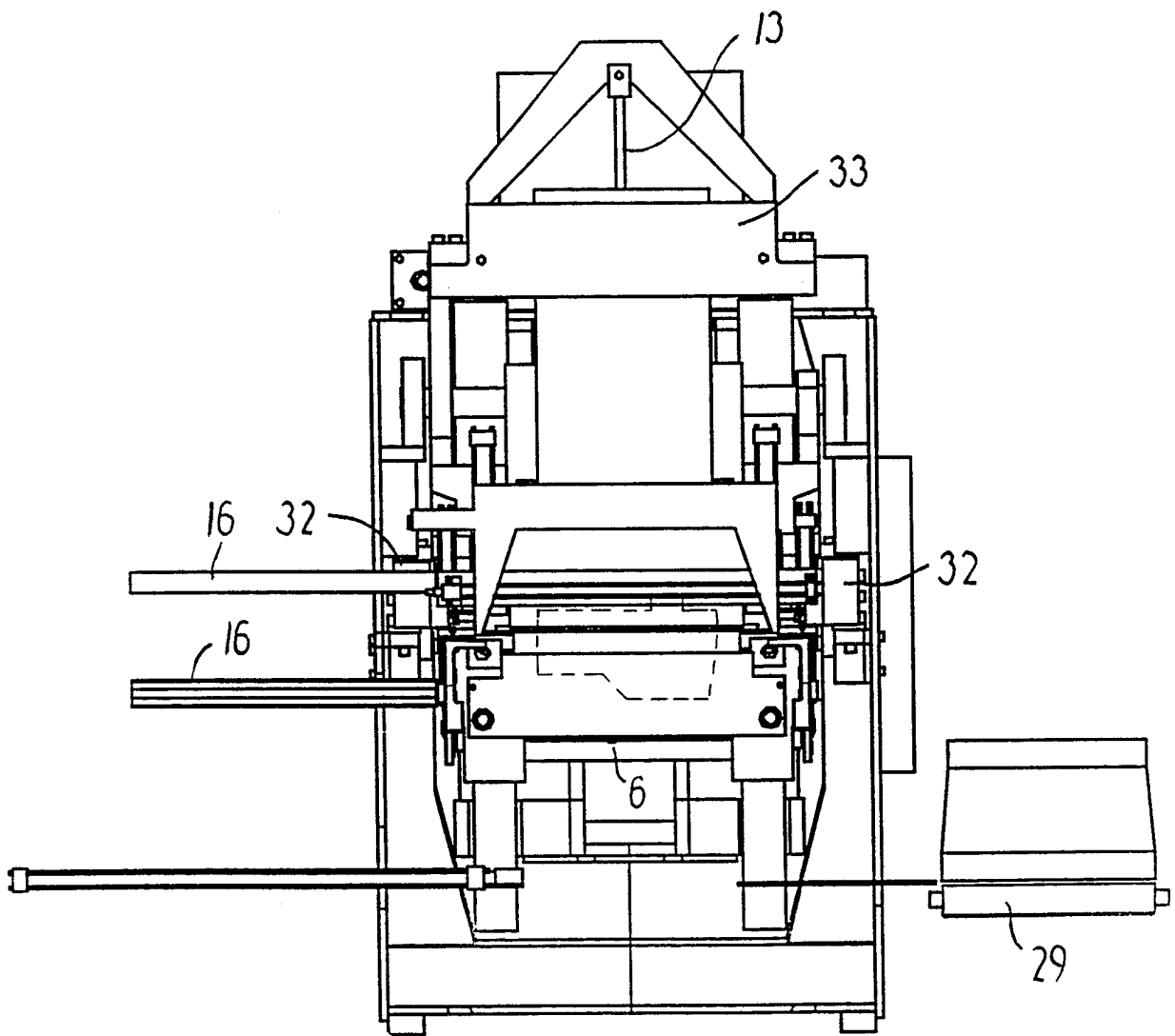

FIG. 4

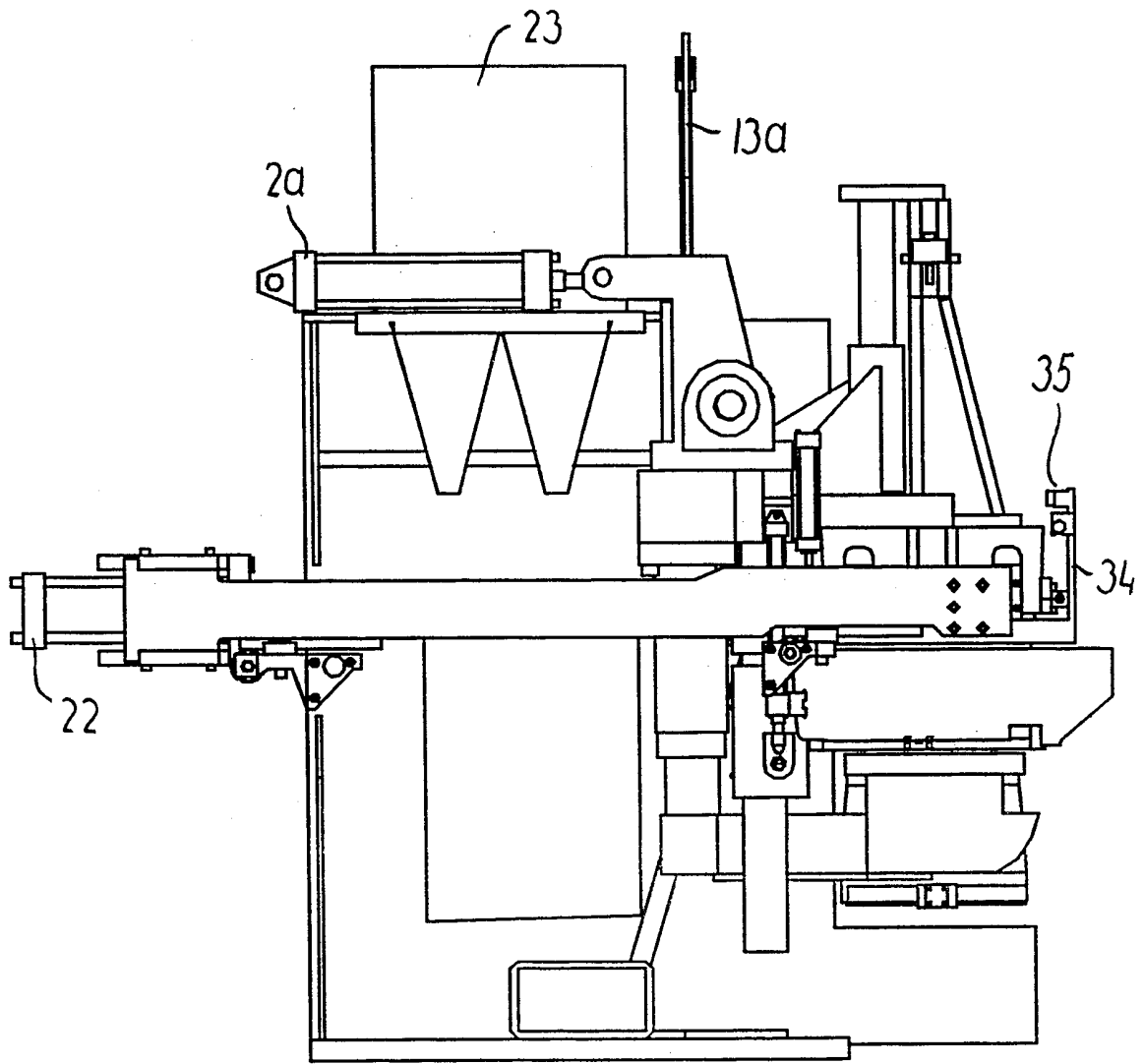

FIG. 4.1

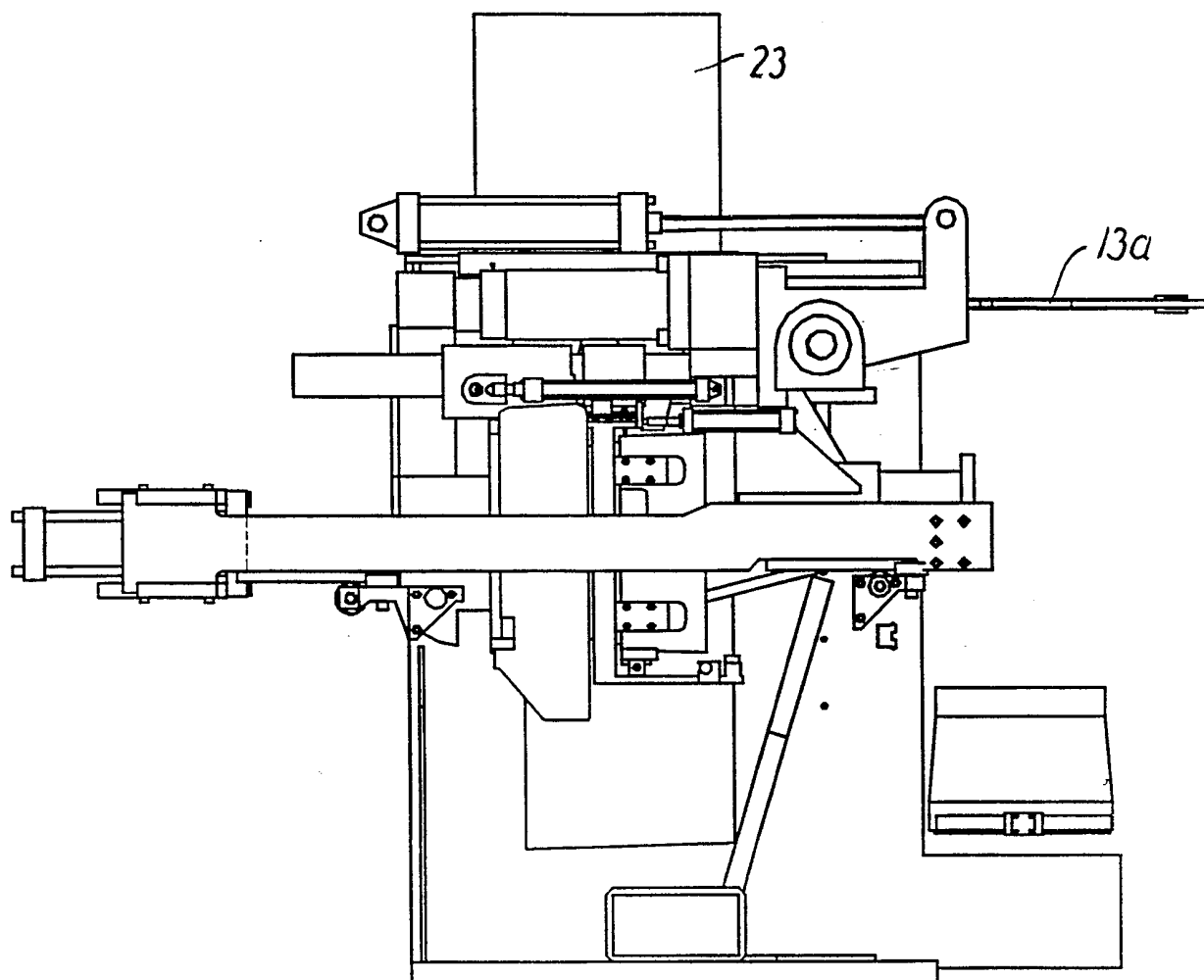

FIG. 5

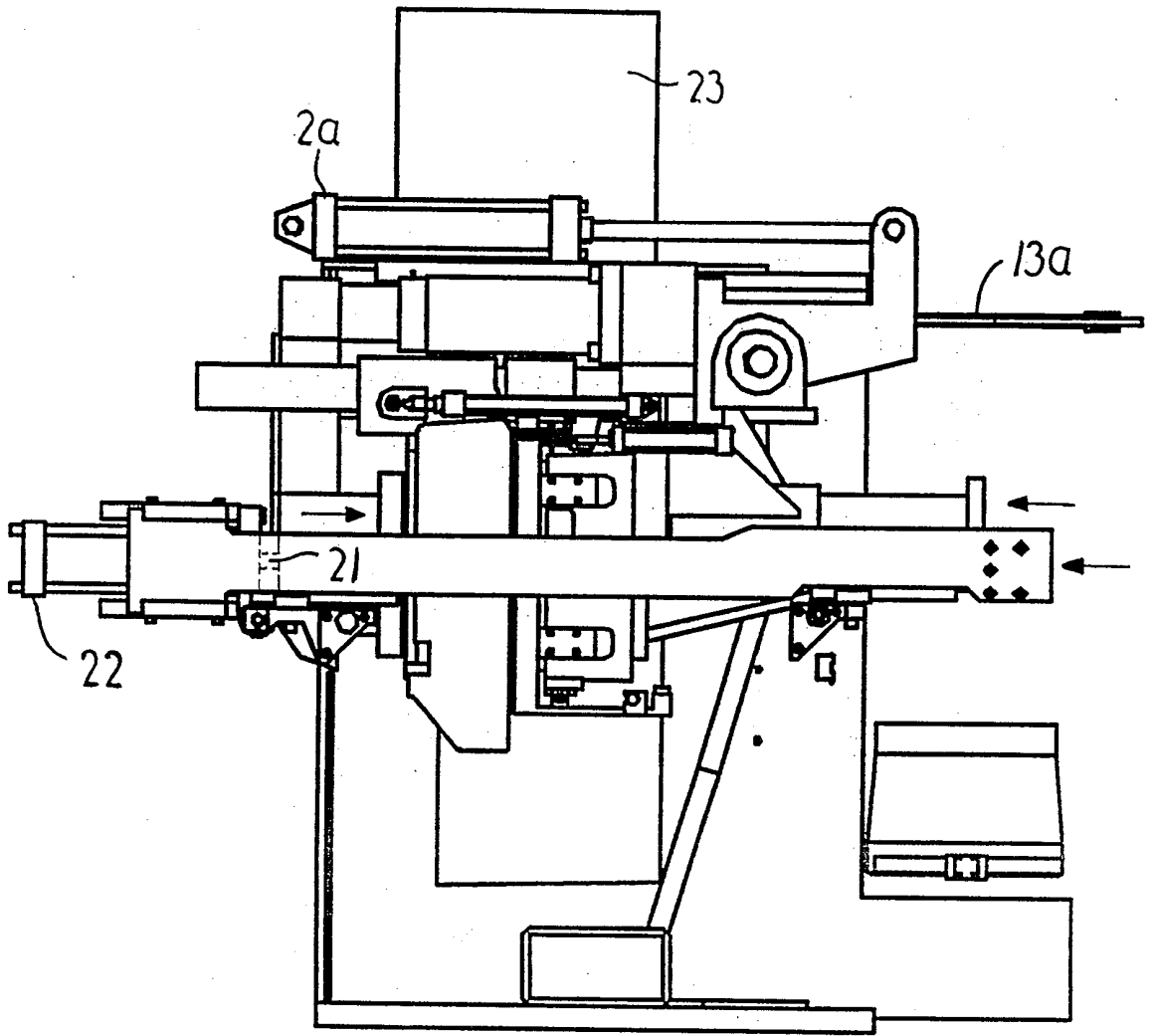

FIG. 6

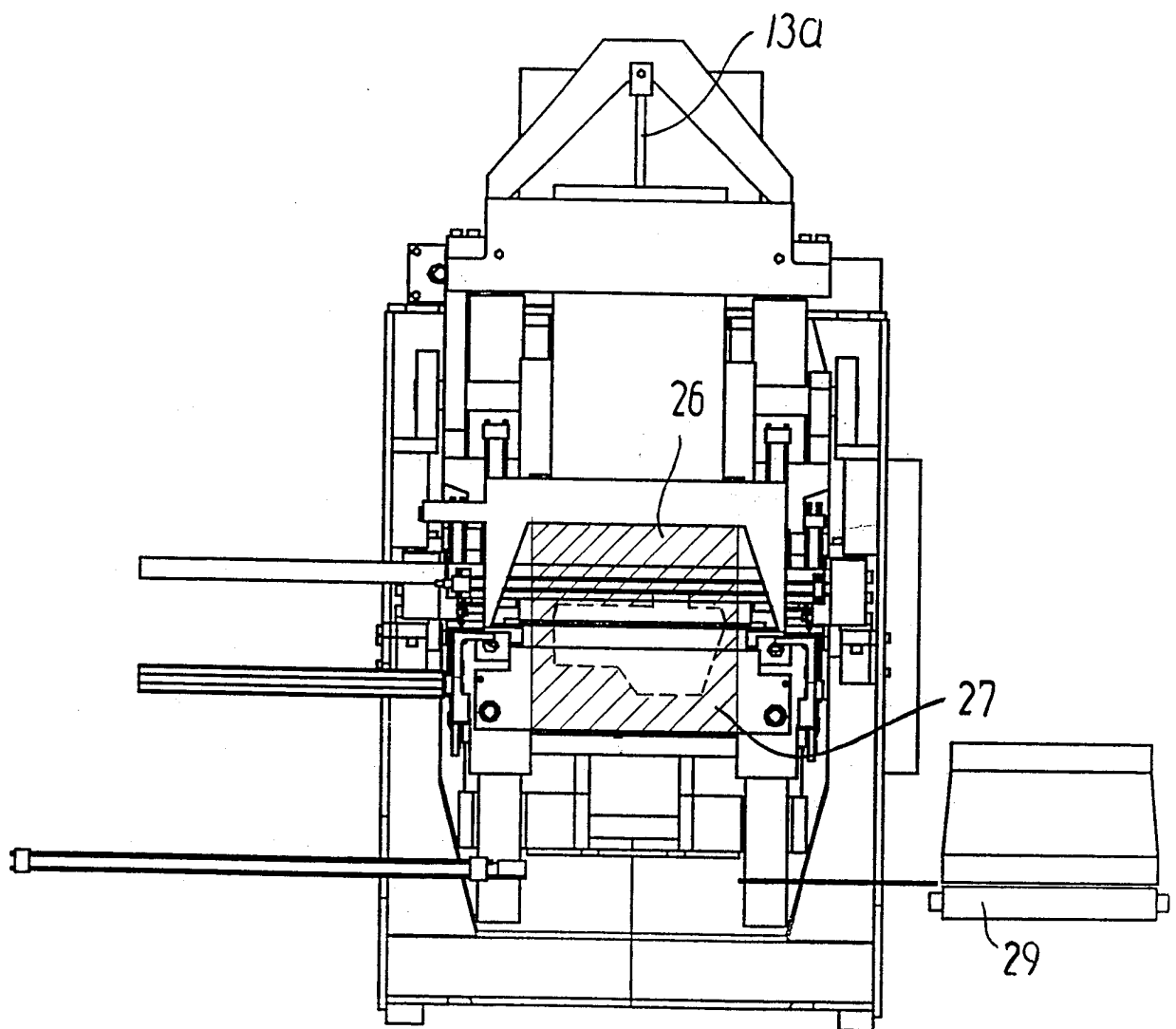

FIG. 7

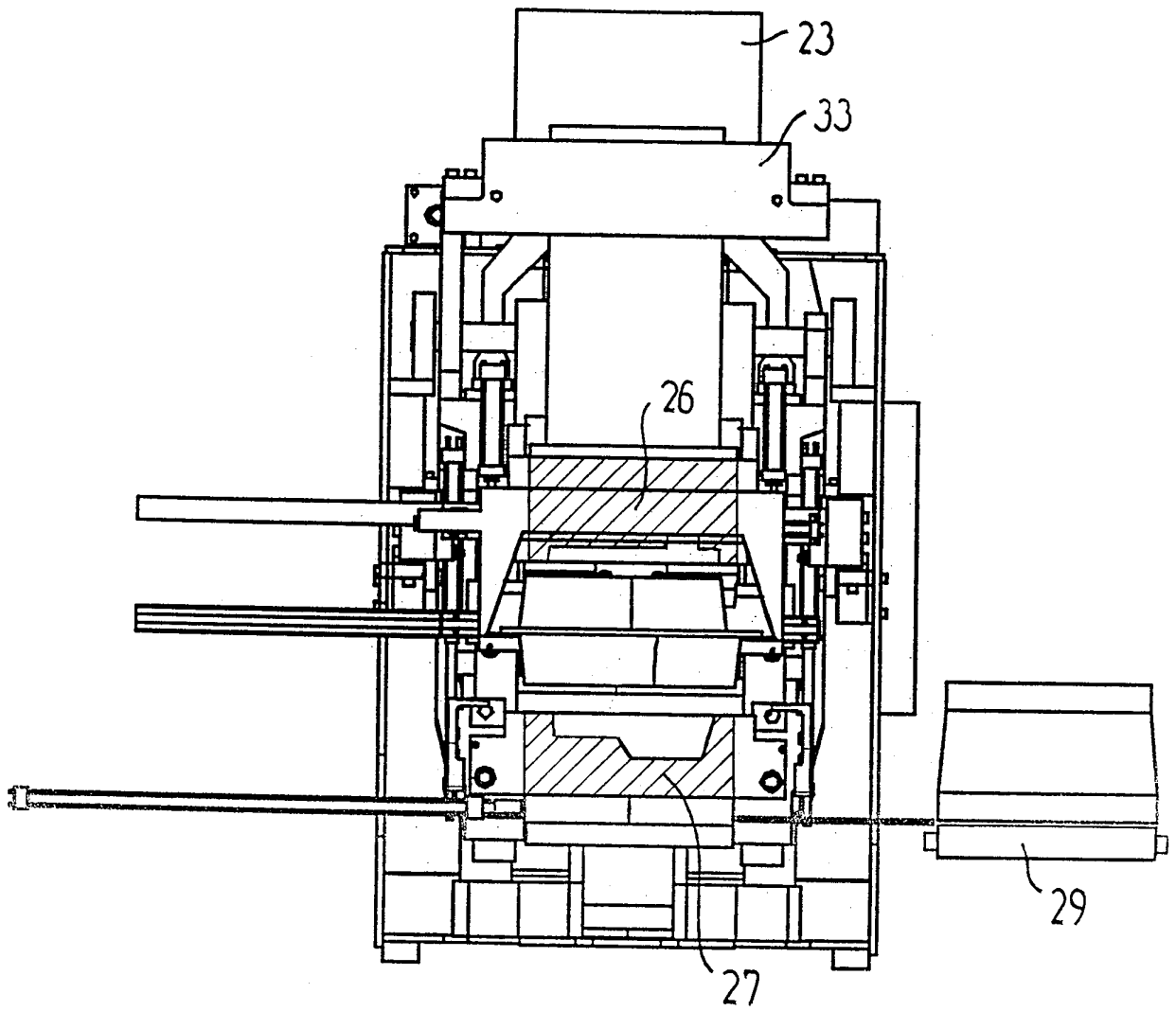

FIG. 8

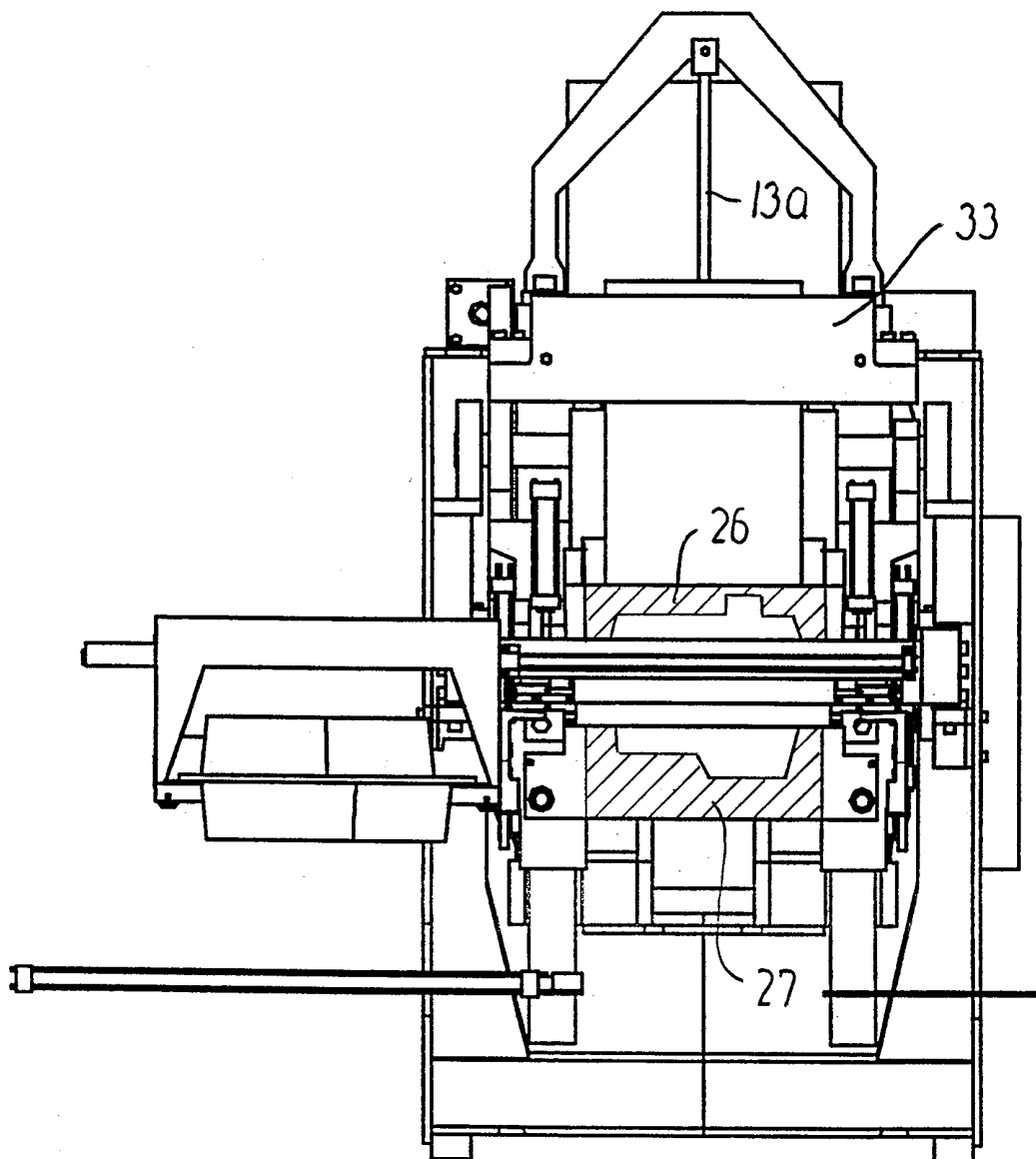

FIG. 9

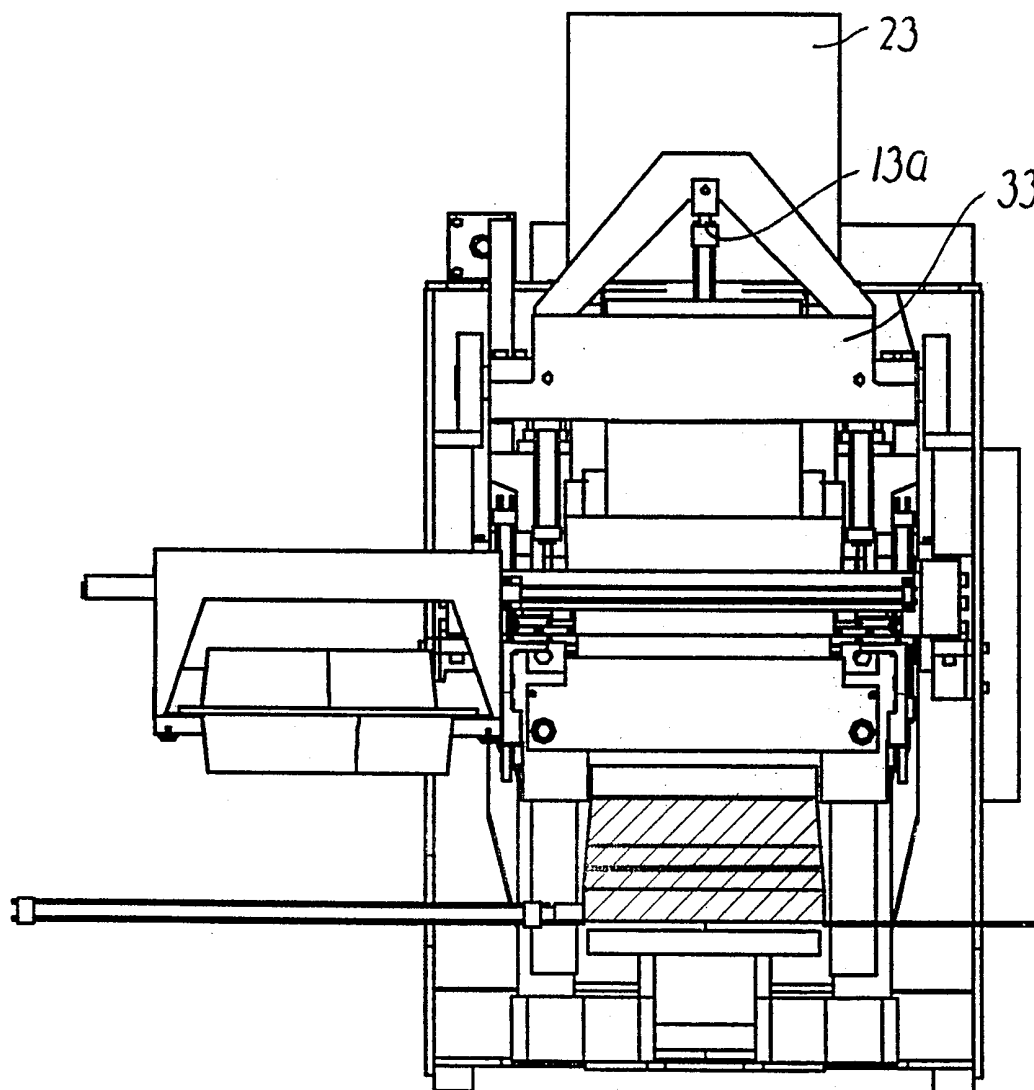

FIG. 10

INTERNATIONAL SEARCH REPORT

International Application No

PCT/DK 99/00077

A. CLASSIFICATION OF SUBJECT MATTER

IPC 7 B22C11/10

According to International Patent Classification (IPC) or to both national classification and IPC

B. FIELDS SEARCHED

Minimum documentation searched (classification system followed by classification symbols)

IPC 7 B22C

Documentation searched other than minimum documentation to the extent that such documents are included in the fields searched

Electronic data base consulted during the international search (name of data base and, where practical, search terms used)

C. DOCUMENTS CONSIDERED TO BE RELEVANT

Category ^o	Citation of document, with indication, where appropriate, of the relevant passages	Relevant to claim No.
A	EP 0 468 355 A (SINTOKOGIO LTD) 29 January 1992 (1992-01-29) cited in the application figures 6,7 -----	1

Further documents are listed in the continuation of box C.

Patent family members are listed in annex.

^o Special categories of cited documents :

"A" document defining the general state of the art which is not considered to be of particular relevance

"E" earlier document but published on or after the international filing date

"L" document which may throw doubts on priority claim(s) or which is cited to establish the publication date of another citation or other special reason (as specified)

"O" document referring to an oral disclosure, use, exhibition or other means

"P" document published prior to the international filing date but later than the priority date claimed

"T" later document published after the international filing date or priority date and not in conflict with the application but cited to understand the principle or theory underlying the invention

"X" document of particular relevance; the claimed invention cannot be considered novel or cannot be considered to involve an inventive step when the document is taken alone

"Y" document of particular relevance; the claimed invention cannot be considered to involve an inventive step when the document is combined with one or more other such documents, such combination being obvious to a person skilled in the art.

"&" document member of the same patent family

Date of the actual completion of the international search

8 October 1999

Date of mailing of the international search report

15/10/1999

Name and mailing address of the ISA

European Patent Office, P.B. 5818 Patentlaan 2
NL - 2280 HV Rijswijk
Tel. (+31-70) 340-2040, Tx. 31 651 epo nl,
Fax: (+31-70) 340-3016

Authorized officer

WOUDENBERG, S

INTERNATIONAL SEARCH REPORT

Information on patent family members

International Application No

EP/DK 99/00077

Patent document cited in search report	Publication date	Patent family member(s)	Publication date
EP 0468355 A	29-01-1992	JP 2772859 B	09-07-1998
		JP 4084647 A	17-03-1992
		DE 69128381 D	22-01-1998
		DE 69128381 T	30-04-1998
		US 5246058 A	21-09-1993
