

June 22, 1965

L. TEXSIER

3,191,133

INTERFERENCE SUPPRESSOR FOR INTERNAL COMBUSTION ENGINES

Filed Sept. 5, 1961

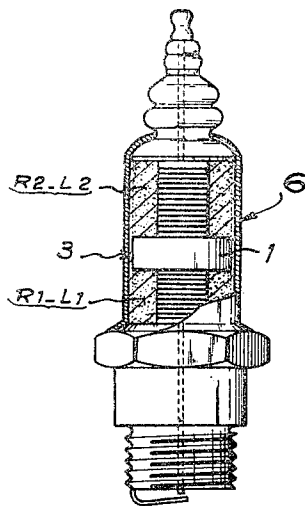
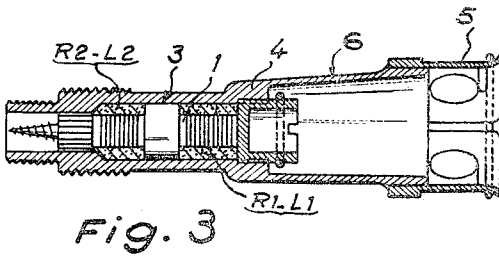
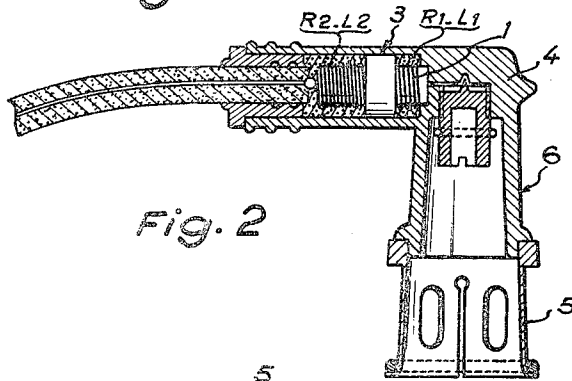
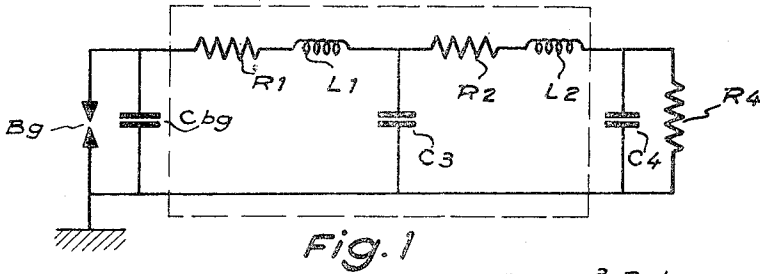

INVENTOR
LÉON TEXSIER
BY *Racon & Thomas*
ATTORNEYS

1

2

3,191,133
INTERFERENCE SUPPRESSOR FOR INTERNAL COMBUSTION ENGINES

Léon Texsier, 21 Rue du Pont Neuf, Paris, France
Filed Sept. 5, 1961, Ser. No. 135,973

Claims priority, application France, Apr. 25, 1961,
859,839

3 Claims. (Cl. 333—79)

An ignition system for an internal combustion engine constituted by a contact breaker, a coil, a distributor and a sparking plug may be considered as a generator of damped electrical oscillations, the frequencies of which extend over a range of values which is ill-defined by reason of the complexity of the different parameters involved.

In fact, the frequency band of the oscillations produced when the spark jumps across the electrodes of the plug (acting as a negative resistance) may extend to several megacycles according to the values of the distributed capacities and the inductance value of each constituent member of the ignition system and the assembly thereof.

Apart from this, other oscillations, the frequencies of which are to be found in a range of values ranging from a few megacycles to several hundreds and probably several thousands of megacycles, are produced as a result of the excitation of the connections of the ignition system interconnecting the different members, particularly the connections connecting the distributor head to the plugs and that connecting this head to the coils. Such an excitation comes from the production of steep-fronted oscillations produced when the jumping of the spark between the electrodes of the plug is begun and finished.

Also the connections near the ignition system, such as those connecting the battery and the headlamps in an automobile vehicle, for example, are in their turn excited in the same way and produce parasitic oscillations.

The total result of the parasitic oscillations thus produced causes considerable disturbance when radio electrical waves are received and this happens in extremely extended frequency band values.

Numerous means intended to reduce the effects of the disturbance phenomena have already been proposed. But in actual fact it is found that if these known means do allow a suppression to be achieved which is generally more satisfactory the greater its complexity, they jeopardize the ignition conditions for the plug.

Up to now all the known and used systems may be substantially placed in two categories:

(1) The one which makes use either of the integral screening of the entire ignition system of the engine (aircraft etc.) or the partial screening of members (connectors, cables etc.).

(2) The other which makes use of the introduction into the circuits of "damping" members, that is to say more or less virtual "resistances" or "inductances."

Apart from the integral screening method which stems from a different and particularly expensive technique, the other solutions cannot be considered as usefully efficient from the point of view of suppression for a sufficiently large frequency band and are not entirely free from the production of interference during the actual ignition process itself.

The present invention has for an object to make a suppressor device of the second category mentioned above, designed so as simultaneously to obtain an efficient suppression for a very large range of frequencies and conditions favorable to ignition while retaining a retail price allowing it to be extensively applied to all types of vehicles.

The invention is based on the fact that the residual

capacity of many types of plugs in current use is of a very substantially constant value of the average order of 15 μfarad .

The principle from which the invention comes consists in using this residual capacity as an active member of the suppressor device instead of considering it as an inevitable parasitic part.

A suppressor device according to the invention intended to be directly inserted between the plug, having a determined residual capacity C_{bg} , and the plug lead, also by construction having a determined capacity C_4 , is characterized in that it is constituted by a low pass T-filter network, this network on the one hand comprising, in series, two assemblies resistor R_1 and inductance and resistor R_2 and inductance L_2 respectively formed by a resistance R_1 or R_2 in series with an inductance L_1 or L_2 and on the other hand, in shunt, a capacity of value C_3 which is in the neighborhood of the value of the residual capacity C_{bg} of the plug, these values of the different aforementioned parameters being interconnected by the following relationships:

$$\sqrt{2} < R_1 \sqrt{\frac{C_{bg}}{L_1}} < 2$$

$$\sqrt{2} < R_2 \sqrt{\frac{C_3}{L_2}} < 2$$

$$\sqrt{2} < R_1 \sqrt{\frac{C_3}{L_1}} < 2$$

$$\sqrt{2} < R_2 \sqrt{\frac{C_4}{L_2}} < 2$$

and also preferably

$$\sqrt{2} < R_1 \sqrt{\frac{C_{bg} \times C_3}{C_{bg} + C_3}} < 2$$

$$\sqrt{2} < R_2 \sqrt{\frac{C_3 \times C_4}{C_3 + C_4}} < 2$$

the values of the resistance being expressed in ohms, those of the capacities in farads and those of the inductances in henrys.

In fact it is found that, by reason of its direct insertion between the plug with the residual capacity C_{bg} , and the plug lead with a capacity C_4 , the low pass T-filter network in fact, by reason of the presence of these capacities C_{bg} and C_4 , forms an assembly which from the point of view of electrical operation is equivalent to the connection in series of two low pass π -filters. The first of these networks is constituted by the series arrangement R_1, L_1 and the shunt arrangement of the capacitive members C_{bg} and C_3 . The second of these networks is constituted of the series assembly R_2, L_2 and of the capacitive members C_3 and C_4 in shunt, the capacity C_3 thus being common to the two networks.

It should be noted that the constitution of these filter networks of a suppressor device according to the invention stems from two interconnected physical principles.

In the first place these filter networks are low-pass networks, the voltage attenuation of which, as a function of the frequency, is, as calculus shows, 12 decibels per octave per network. As in this case we are dealing with a pulse carrier wave with a very large frequency range conducted via the filters to the input of a connection, the other end of which is open, it may be seen that this oscillation will pass through four networks in a to and fro movement which gives an attenuation of 48 decibels per octave beyond the individual cut-off frequency of the networks.

In the second place, these filters, the relative values of the elements of which are determined in order to form a critical damping, have the property of transforming the pulse signal appearing at the terminals of the plug at the beginning and at the end of the spark into a signal of very rounded shape, the rise time of which is determined by the values of the elements. This latter signal which thus appears at the output of the filters coming from the plug will, after being propagated along the connection the end of which is open, undergo a reflection and will return to the filters where it will be absorbed. By reason of its very shape there is once more to be found a strong limitation of its frequency range in relation to the pulse produced by the plug.

During this time, and this is essential, for here is shown an improvement in ignition, the current of the spark of the plug due to this phenomenon will have been exponentially decreasing without oscillations as in the case of a direct connection and thus with no successive passing through cancellations with a reversal of direction. In other words the energy provided to the plug will, from the moment at which the spark jumps, have been uniformly decreasing and will be cancelled only once. When the spark stops, a new pulse signal appears; the latter, with a voltage which is much lower than the first, will be rapidly absorbed in a to and fro movement without there taking place any spark between the electrodes of the plug.

In order that the invention may be more clearly understood, reference will now be made to the accompanying drawings which show some embodiments thereof by way of example and in which:

FIGURE 1 shows an electrical circuit diagram of a suppressor device according to the present invention, and FIGURES 2 to 4, by way of example, show different embodiments of the actual device.

Referring first to FIGURE 1, in this drawing have been diagrammatically shown the electrodes B_g of the plug, the residual capacity of the latter being denoted by C_{bg} . The actual suppressor device directly inserted between the plug and the plug lead is shown inside broken lines, and is made up of the low pass T-filter network comprising, in series, the resistance R_1 =inductance L_1 and resistance R_2 =inductance L_2 and, in shunt, the capacity C_3 .

The plug lead is represented by its equivalent circuit comprising the capacity C_4 and the resistance R_4 . The capacity C_4 is that of this conductor in relation to earth and the resistance R_4 is the equivalent resistance of the leakages by radiation and ohmic resistance.

The method of operation of the device is as follows: when the spark is jumping the terminals of the electrodes of the plug B_g , the pulse wave which is produced on these electrodes first of all passes through the assembly of the members R_1 , L_1 and C_3 and then reaches the input of the plug lead via the members R_2 and L_2 .

The existence of the capacity C_4 is due to the fact that the pulse wave appearing at the plug in the course of its first passage through the members R_1 , L_1 and C_3 undergoes considerable weakening of its high frequency components in such a way that, for the components of the low frequencies, the plug lead at its input constitutes a capacitative member. The high frequency components of the range although weakened undergo reflection at the other end of the conductor and return. It may be seen that the reflected wave must pass through the first assembly L_2 , R_2 and C_3 and then the second assembly L_1 , R_1 and C_{bg} . Mathematical study shows that it is necessary that the values of the different members are such that the three adjacent members R , L , C considered in a filter have an extra voltage comprised between 0.7 (a value for which the amplitude/frequency curve of the assembly R , L , C is always decreasing) and 0.5, a value for which critical damping conditions obtain.

In other words one should have the following relationships:

(1) Since C_{bg} is an imposed value equal on average to 15 $\mu\mu\text{farad}$:

$$\begin{aligned} C_3 &= C_{bg} \\ R_1 &= R_2 \\ L_1 &= L_2 \end{aligned} \quad (1)$$

$$\sqrt{2} < R_1 \sqrt{\frac{C_{bg}}{L_1}} < 2 \quad (2-1)$$

$$\sqrt{2} < R_2 \sqrt{\frac{C_3}{L_2}} < 2 \quad (2-2)$$

$$\sqrt{2} < R_1 \sqrt{\frac{C_3}{L_1}} < 2 \quad (2-3)$$

and finally

$$\sqrt{2} < R_2 \sqrt{\frac{C_4}{L_2}} < 2 \quad (2-4)$$

this latter relationship being automatically verified if it be taken into consideration that in general C_4 is of a value very little different from that of C_{bg} .

(3) Finally another group of conditions which may be termed "non resonance" due to the capacities placed in series in pairs, impose:

$$\sqrt{2} < R_1 \sqrt{\frac{C_{bg} \times C_3}{C_{bg} + C_3}} \quad (3-1)$$

$$\sqrt{2} < R_2 \sqrt{\frac{C_3 \times C_4}{C_3 + C_4}} \quad (3-2)$$

All the above mathematical constructions thus allow the values of each of the constituent members of the filters to be precisely determined.

For example, in a particular case the following numerical values will be obtained

$$\begin{aligned} C_{bg} &= 12 \mu\mu\text{f.} \\ R_1 &= 1.400 \Omega \\ L_1 &= 20 \mu\text{h.} \end{aligned}$$

with a capacity of the assembly R_1 and L_1 in relation to earth lower than 0.5 $\mu\mu\text{f.}$

$$\begin{aligned} C_3 &= 14 \mu\mu\text{f.} \\ R_2 &= 1.400 \Omega \\ L_2 &= 20 \mu\text{h.} \end{aligned}$$

with a capacity of the assembly R_2 and L_2 in relation to earth lower than 0.5 $\mu\mu\text{f.}$

In the embodiments shown by way of example in FIGURES 2 and 3, the members comprising resistor R_1 and inductance L_1 and resistor R_2 and inductance L_2 are formed by winding a resistant wire on to a core 1 of suitable insulating material which simultaneously allows the intended values for R and L of each of the networks of the filter to be obtained, that is to say an inductance and a resistance formed according to the above relationships.

In the middle of the core is a flange 2 on which is mounted a metal ring 3 (or alternatively the flange 2 may be metallized) and would thus constitute one of the electrodes of the capacity C_3 . At the same time, the ring 3 fills the role of a lossless screen between two coils which are thus not coupled.

These coils are mounted in the body of a connector 4 of plastic material which is suitable by reason of its dielectric qualities (rigidity and permanence), the outside 6 of which is either metallized by a known method or inserted in a metal envelope and this forms the second electrode of the capacity C_3 . This conductive portion, together with a device 5 ensuring the non-inductive contact on the body of the plug, ensures the electrical "earth"

5

return common to the assembly of the elements of the filters.

The other portions of this embodiment, e.g. fixation on the output electrode of the plug, the output of the cable etc., are conventional.

In another embodiment the assembly of the suppressor device is mounted directly in the body of a plug, as shown in FIGURE 4. In this figure the same reference numerals indicate the same members as in FIGURES 2 and 3.

I claim:

1. An interference suppressor device for internal combustion engines, for direct insertion between the spark-plug, which has a determined residual capacity C_{bg} , and the plug lead, which has a determined capacity C_3 , said suppressor device being constituted by a low pass T-filter network, said network on the one hand comprising, in series, two assemblies resistor R_1 and inductance L_1 and resistor R_2 and inductance L_2 respectively formed by a resistance R_1 or R_2 in series with an inductance L_1 or L_2 and on the other hand, in shunt, a capacity of value C_3 near to the value of the residual capacity of the plug C_{bg} , the values of the different aforementioned parameters being interconnected by the following relationships:

$$\sqrt{2} < R_1 \sqrt{\frac{C_{bg}}{L_1}} < 2$$

$$\sqrt{2} < R_2 \sqrt{\frac{C_3}{L_2}} < 2$$

$$\sqrt{2} < R_1 \sqrt{\frac{C_3}{L_1}} < 2$$

$$\sqrt{2} < R_2 \sqrt{\frac{C_4}{L_2}} < 2$$

6

and also preferably

$$\sqrt{2} < R_1 \sqrt{\frac{C_{bg} \times C_3}{C_{bg} + C_3}} < 2$$

$$\sqrt{2} < R_2 \sqrt{\frac{C_3 \times C_4}{C_3 + C_4}} < 2$$

10 the values of the resistances being expressed in ohms, those of the capacities in farads and those of the inductances in henrys.

2. A device as claimed in 1, in which: the two members resistor R_1 and inductance L_1 and resistor R_2 and inductance L_2 are made in the form of two coils on a core of insulating material, having a support between the coils for a metal ring or a metallized layer constituting one of the electrodes of the capacity C_3 , the other terminal of this capacity being made in the form of the outer metallisation of a connector of insulating material inside which is located the aforementioned core.

3. A device as claimed in claim 2, in which said connector is a unitary part of said spark plug.

References Cited by the Examiner

UNITED STATES PATENTS

1,723,908	8/29	Alexanderson	333-79
1,946,680	2/34	Franklin	333-79
1,984,526	12/34	Gwen	123-148
2,238,915	4/41	Peters	333-81
2,322,773	6/43	Peters	174-119
2,894,221	7/59	Coy	333-79
3,002,126	9/61	Noir	315-58

HERMAN CARL SAALBACH, Primary Examiner.