

J. W. HILDRETH.

MACHINE FOR BOARDING LEATHER.

No. 104,454.

Patented June 21, 1870.

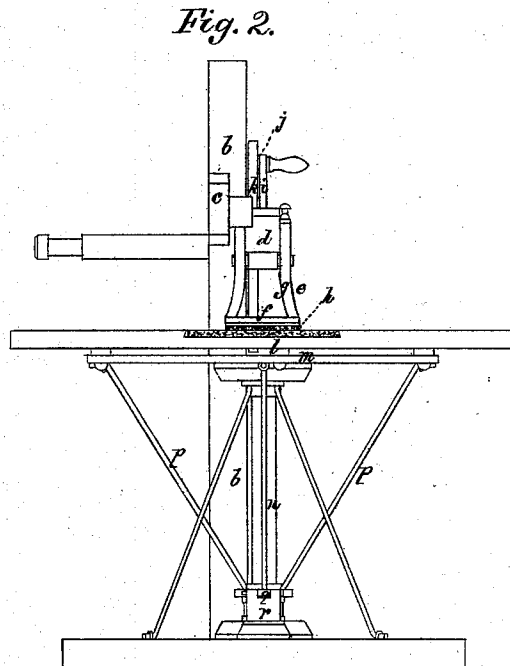
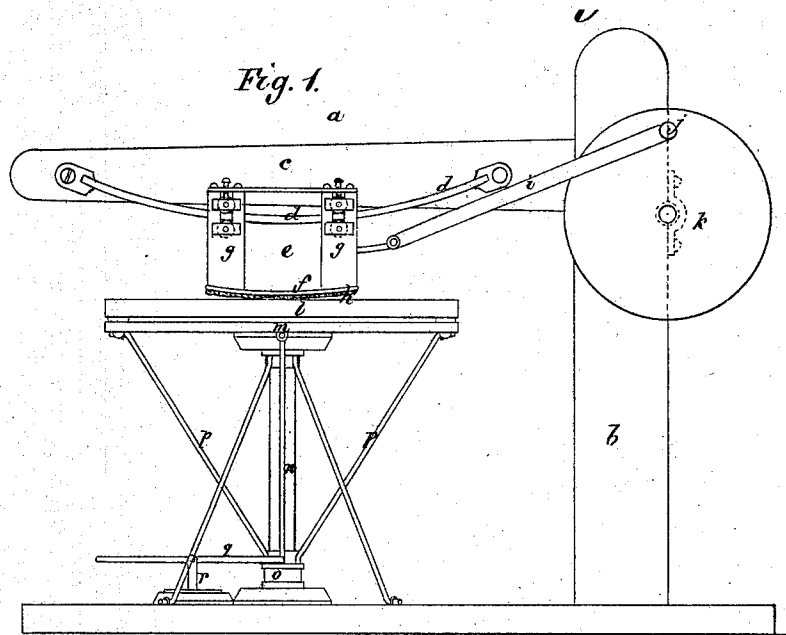

Witnesses.

Geo. A. Loring

E. Sniffen

Joseph Watson Hildreth

by his Attorney

Fredrick Curtis

# United States Patent Office.

JOSEPH WARSON HILDRETH, OF BOSTON, MASSACHUSETTS.

Letters Patent No. 104,454, dated June 21, 1870.

## IMPROVED MACHINE FOR BOARDING LEATHER.

The Schedule referred to in these Letters Patent and making part of the same

To all to whom these presents shall come:

Be it known that I, JOSEPH WARSON HILDRETH, of Boston, in the county of Suffolk and State of Massachusetts, have made an invention of a new and useful Improvement in Machinery for "Boarding Leather," so called; and do hereby declare the following to be a full, clear, and exact description thereof, due reference being had to the accompanying drawing making part of this specification, and in which—

Figure 1 is a perspective representation, and

Figure 2 an elevation of a machine embodying my improvements.

The object of my invention is to produce a motion to the boarding instrument more nearly approximating to that of human manipulation, by which a much better action is exerted upon the leather than by any machinery heretofore in use.

To this end, the reciprocating carriage, which carries the boarding device, is supported and slides upon curved ways suspended above the table, by which means the boarding instrumentality is caused to travel to and fro of the surface of the leather in a path approximating to a sector of a circle, this motion having been found in practice the one best calculated to produce the most perfect surface upon such leather.

In the drawing hereinbefore alluded to as accompanying this specification, and which illustrates my invention—

*a* denotes a gallows-frame, of which *b* is the upright post, and

*c* the horizontal arm which surmounts the operating tablet, to be hereinafter explained.

To one side of this arm *c* a curved plate or guide, *d*, in the form of an inverted arch or segment of a circle, is affixed, while sliding upon this plate or way is the carriage which carries the boarding instrument.

This carriage is represented at *e* as composed of a base-plate, *f*, and two end uprights *g g*, substantially after the manner of the head-stock of an ordinary turning-lathe, the boarding instrument or device which is usually simply a piece of cork, being secured to the under side of the carriage *e*, as represented at *h* in the drawing.

The carriage *e* may be provided with anti-friction rollers as a means of suspension from the bar *d*, or it may simply slide thereupon after the manner of the cross-head of a steam-engine.

A pitman, *i*, connects one end of the carriage *e* with the wrist-pin *j* of a crank-wheel, *k*, mounted upon the post *b*, by which means to and fro reciprocations of the carriage upon its suspensory are effected.

The support for the leather, while undergoing the "boarding" process, is exhibited at *l* as a flat tablet

mounted upon a table, *m*, the connection between the two being preferably an elastic or yielding one, and which may be effected in a variety of ways.

The table *m* is supported upon the top of a post, *n*, and upon which it freely slides, this post being erected upon the floor of the structure in which the machine is situated, or upon any suitable foundation.

A sleeve, *o*, slides freely upon or about the lower part of the post, and is connected with the table *m* by oblique braces or feet *p p*, which are secured to the two, as represented, this sleeve and the feet serving as an economical means of steadying the vertical motion of the table.

The post *n* is also braced in a suitable manner, while an elastic washer may, if considered desirable, be interposed between the sleeve *o*.

A lever or treadle, *q*, is fulcrumed to a post, *r*, erected upon the floor or foundation of the building, and adjacent to the post *n*, the inner end of this treadle being furcated and embracing the sleeve *o*, before-mentioned, the whole being so arranged that, by means of the treadle or lever *q*, elevations or depressions of the table and its tablet upon the post *n*, and toward or away from the boarding-tool, may be easily effected.

The mode of suspending the boarding-tool carriage, as hereinbefore explained, enables the angles of incidence and departure of the said tool, with respect to the leather, to be described in such a direction as to impinge upon and leave the same in a gradual and easy curve, and without the abrupt and injurious impact now common to machines of this nature.

I am aware that a pendulistic motion has been imparted to the boarding-tool by suspending it from a pivot, and I do not claim broadly causing the tool to vibrate in a curved path.

The objections to the use of a pivot are that, in order to obtain the gradual and easy approach of the tool to the leather, the arc of the circle in which it swings must be so large that the axis must necessarily be removed a considerable distance from the table, and the tool is then suspended from the end of a long swinging radius or arm, which is likely to fail in properly supporting and steadying the tool; and again, the tool, in such case, must always swing in the arc of a circle; but by my improvement, that is to say, by the employment of the curved guide or way upon which the tool slides, the tool is supported and braced at a point immediately above and in proximity to the leather, the curve may be as gradual as desired without increasing the size of the machine, and, instead of being an arc of a circle, it may be a parabolic or other suitable curve.

I would remark that the upper surface of the tablet *l* is to be provided with a plate of cork, after the manner of leather-boarding machines now in general use.

What I claim, and desire to secure by Letters Patent, is—

The combination, with the leather-supporting bed or tablet, of the reciprocating boarding-tool carriage,

supported by and moving in or upon a curved guide or way, *d*, substantially as and for the purposes set forth.

JOSEPH WARSON HILDRETH.

Witnesses:

FRED. CURTIS,  
E. GRIFFITH.