

(No Model.)

A. H. WOODRUFF.
FURNACE.

No. 526,475.

Patented Sept. 25, 1894.

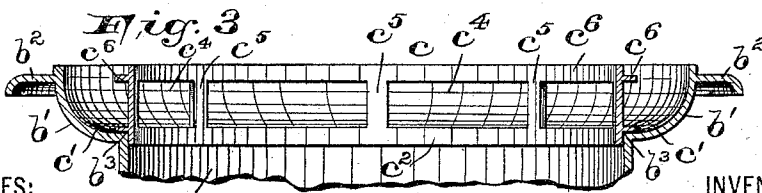
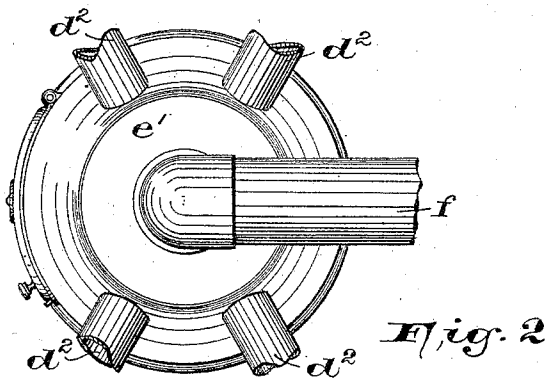
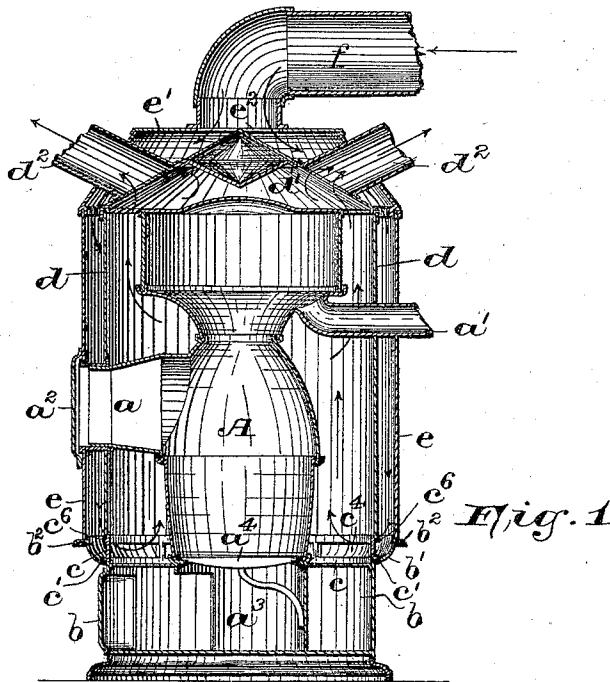

WITNESSES:

Wm. O. Bamfield, Jr.
4 Basil Hoopw.

INVENTOR:

Augustus H. Woodruff,

BY Fred C. Grantzel, ATT'Y.

UNITED STATES PATENT OFFICE.

AUGUSTUS H. WOODRUFF, OF VAILSBURG, NEW JERSEY.

FURNACE.

SPECIFICATION forming part of Letters Patent No. 526,475, dated September 25, 1894.

Application filed January 16, 1894. Serial No. 497,042. (No model.)

To all whom it may concern:

Be it known that I, AUGUSTUS H. WOODRUFF, a citizen of the United States, residing at Vailsburg, in the county of Essex and State of New Jersey, have invented certain new and useful Improvements in Furnaces; and I do hereby declare the following to be a full, clear, and exact description of the invention, such as will enable others skilled in the art to which it appertains to make and use the same, reference being had to the accompanying drawings, and to letters of reference marked thereon, which form a part of this specification.

My invention relates to new and useful improvements in hot-air furnaces, and consists in certain arrangements and combinations of parts, such as will be hereinafter more fully described and finally embodied in the clauses of the claim.

The invention is illustrated in the accompanying sheet of drawings, in which—

Figure 1 is a vertical section of a portable furnace provided with the said outer casing or shell, and Fig. 2 is a top view of the same. Fig. 3 is a detail view representing in cross-section, a portion of the lower casting of the furnace, which is provided with a lip or flange for the support of the outer shell or casing, and also illustrating in connection therewith, a ring, upon which the inner shell or casing is supported, said ring being provided with openings for the admission of the cold air behind the inner shell or casing of the furnace.

Similar letters of reference are employed in each of the above described views to indicate corresponding parts.

In said drawings, A indicates any suitable form of hot air furnace, provided with the smoke-pipe a' and an inlet a and door a^2 .

a^3 is the ash pit and a^4 any suitable form of grate.

In Fig. 1, b indicates a suitable base, which is preferably of cast metal, and is provided at the top, as will be seen from Fig. 3, with an outwardly flaring and curved ring-shaped portion b' , having an annular flange b^2 , substantially as shown. Upon the inner edge b^3 of said casting b is arranged a metal ring c provided with an annular flange or supporting ledge c' , which rests upon the said edge b^3 , in such a manner, that a portion c^2 of said ring c projects down into said base b . In said ring c

are formed any suitable number of openings c^3 , and c^4 are suitable stiffening bars connecting the upper ring portion c^5 with the lower ring portion c^2 . A second annular flange c^6 is formed on the outer surface of said ring c , substantially as shown in Figs. 1 and 3. Upon said flange c^6 is arranged the inner casing or shell d , preferably made of black iron, which casing or shell is provided at the top with a cone-shaped dome d' , from which radiate the hot air flues d^2 , as will be seen from Fig. 2. Upon said annular flange b^2 of the said base b , is arranged an outer shell or casing e , to which is secured on the top thereof, in any well-known manner, a suitably shaped cover e' having an opening e^2 , with which connects the opening of a cold air duct f . As will be seen from Fig. 1, the cold air taken into said cold air duct f , strikes said dome d' and is evenly distributed over the entire surface thereof, passing down between the inner shell or casing d and the outer shell or casing e , into the jacket formed by said casings, from which the air finally passes through the openings c^3 in the ring c , around the body portion A of the furnace to be heated and then forced into the hot air flues d^2 , as indicated by the arrows, shown in said Fig. 1.

By the arrangement of a cold air jacket to be used in connection with a hot air furnace, many advantages are the result. In the first place, the cold air entirely surrounds the hot casing or shell d and during its downward course becomes warm. On the other hand, the outer shell or casing e remains perfectly cold and there is a great saving of the heat usually lost by radiation from the casings of furnaces as now made.

By the arrangement of an air duct to supply fresh air to the top of the furnace, the air strikes the center of the dome d' , and is thereby equally distributed, furnishing every part of the furnace with a fresh supply of air. It also does away with the use of an underground pit and air duct, thus preventing damp and foul air from entering the furnace, and finally, the arrangement and combinations of the parts herein shown and described, result in a cheaper and better construction in every way.

The outer casing or shell e is usually made of galvanized iron.

Having thus described my invention, what I claim is—

1. In a hot air furnace, in combination, with the furnace proper, comprising therein
 5 a base *b*, having a ring-shaped portion *b'*, provided with a flange *b²*, a ring *c*, provided with openings, arranged on said ring-shaped portion *b'*, a shell or casing *d* connected with
 10 said ring *c* and having a dome *d'*, an outer shell or casing *e* arranged on said flange *b²* of the base *b*, and provided with a cover *e'*, said shells or casings forming a cold air jacket, and a cold air duct leading into said jacket, substantially as and for the purposes set forth.
 15 2. In a hot air furnace, in combination, with the furnace proper, comprising therein a base *b*, having a ring-shaped portion *b'*, pro-

vided with a flange *b²*, a ring *c*, provided with a flange or supporting ledge *c'*, a flange *c²*, and openings *c³*, a shell or casing *d* con- 20 nected with said ring *c*, an outer shell or casing *e* arranged on said flange *b²* of said base *b*, and provided with a cover *e'*, said shells or casings forming a cold air jacket, and a cold air duct leading into said jacket, substan- 25 tially as and for the purposes set forth.

In testimony that I claim the invention set forth above I have hereunto set my hand this 13th day of January, 1894.

AUGUSTUS H. WOODRUFF.

Witnesses:

FREDK. C. FRAENTZEL,
 WM. H. CAMFIELD, Jr.