

(12) INTERNATIONAL APPLICATION PUBLISHED UNDER THE PATENT COOPERATION TREATY (PCT)

(19) World Intellectual Property Organization
International Bureau



(43) International Publication Date
11 November 2010 (11.11.2010)

(10) International Publication Number
WO 2010/129446 A1

- (51) International Patent Classification:
A61B 3/16 (2006.01)
- (21) International Application Number:
PCT/US2010/033329
- (22) International Filing Date:
3 May 2010 (03.05.2010)
- (25) Filing Language: English
- (26) Publication Language: English
- (30) Priority Data:
12/434,709 4 May 2009 (04.05.2009) US
- (71) Applicant (for all designated States except US): **ALCON RESEARCH, LTD.** [US/US]; 6201 South Freeway, Fort Worth, TX 76134 (US).
- (72) Inventors; and
(75) Inventors/Applicants (for US only): **DACQUAY, Bruno** [US/US]; 3 Candlebush, Irvine, CA 92603 (US). **RICKARD, Matthew, J., A.** [US/US]; 15210 Fairfax Way, Tustin, CA 92782 (US).
- (74) Agents: **BASSINGER, Kenneth, D.** et al.; 6201 South Freeway, Mail Code: TB4-8, Fort Worth, TX 76134 (US).
- (81) Designated States (unless otherwise indicated, for every kind of national protection available): AE, AG, AL, AM, AO, AT, AU, AZ, BA, BB, BG, BH, BR, BW, BY, BZ, CA, CH, CL, CN, CO, CR, CU, CZ, DE, DK, DM, DO, DZ, EC, EE, EG, ES, FI, GB, GD, GE, GH, GM, GT, HN, HR, HU, ID, IL, IN, IS, JP, KE, KG, KM, KN, KP, KR, KZ, LA, LC, LK, LR, LS, LT, LU, LY, MA, MD, ME, MG, MK, MN, MW, MX, MY, MZ, NA, NG, NI, NO, NZ, OM, PE, PG, PH, PL, PT, RO, RS, RU, SC, SD, SE, SG, SK, SL, SM, ST, SV, SY, TH, TJ, TM, TN, TR, TT, TZ, UA, UG, US, UZ, VC, VN, ZA, ZM, ZW.
- (84) Designated States (unless otherwise indicated, for every kind of regional protection available): ARIPO (BW, GH, GM, KE, LR, LS, MW, MZ, NA, SD, SL, SZ, TZ, UG, ZM, ZW), Eurasian (AM, AZ, BY, KG, KZ, MD, RU, TJ, TM), European (AL, AT, BE, BG, CH, CY, CZ, DE, DK, EE, ES, FI, FR, GB, GR, HR, HU, IE, IS, IT, LT, LU, LV, MC, MK, MT, NL, NO, PL, PT, RO, SE, SI, SK, SM, TR), OAPI (BF, BJ, CF, CG, CI, CM, GA, GN, GQ, GW, ML, MR, NE, SN, TD, TG).
- Published:
— with international search report (Art. 21(3))

(54) Title: INTRAOCULAR PRESSURE SENSOR

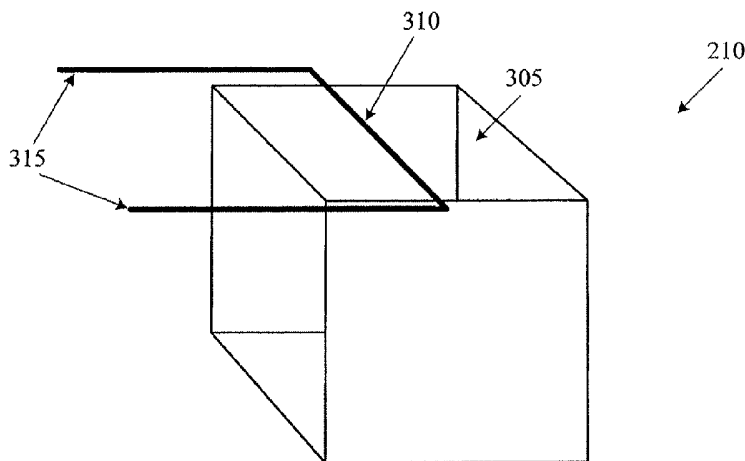

Fig. 3

(57) Abstract: An implantable intraocular pressure sensor system has a sealed geometric shape with an internal pressure at a first value. A strain gauge wire is embedded in a surface of the sealed geometric shape. When the surface is deflected by intraocular pressure, a measured resistance of the strain gauge wire indicates the intraocular pressure. The system also has a processor coupled to a power source and memory. The processor is configured to read the measured resistance and write values corresponding to intraocular pressure to the memory.

WO 2010/129446 A1

INTRAOCULAR PRESSURE SENSOR

BACKGROUND OF THE INVENTION

5 The present invention relates to a device for monitoring intraocular pressure and more particularly to an implantable pressure sensor.

 Glaucoma, a group of eye diseases affecting the retina and optic nerve, is one of the leading causes of blindness worldwide. Glaucoma results when the intraocular pressure (IOP) increases to pressures above normal for prolonged periods of time. IOP can increase due to an imbalance of the production of aqueous humor and the drainage of the aqueous humor. Left untreated, an elevated IOP causes irreversible damage the optic nerve and retinal fibers resulting in a progressive, permanent loss of vision.

15 The eye's ciliary body epithelium constantly produces aqueous humor, the clear fluid that fills the anterior chamber of the eye (the space between the cornea and iris). The aqueous humor flows out of the anterior chamber through the uveoscleral pathways, a complex drainage system. The delicate balance between the production and drainage of aqueous humor determines the eye's IOP.

 Open angle (also called chronic open angle or primary open angle) is the most common type of glaucoma. With this type, even though the anterior structures of the eye appear normal, aqueous fluid builds within the anterior chamber, causing the IOP to become elevated. Left untreated, this may result in permanent damage of the optic nerve and retina. Eye drops are generally prescribed to lower the eye pressure. In some cases, surgery is performed if the IOP cannot be adequately controlled with medical therapy.

30 Only about 10% of the population suffers from acute angle closure glaucoma. Acute angle closure occurs because of an abnormality of the structures in the front of the eye. In most of these cases, the space between the iris and cornea is more narrow than normal, leaving a smaller channel for the aqueous to pass through. If the flow of aqueous becomes completely blocked, the IOP rises sharply, causing a sudden angle closure attack.

 Secondary glaucoma occurs as a result of another disease or problem within the eye such as: inflammation, trauma, previous surgery, diabetes, tumor, and certain

medications. For this type, both the glaucoma and the underlying problem must be treated.

Figure 1 is a diagram of the front portion of an eye that helps to explain the processes of glaucoma. In Figure 1, representations of the lens 110, cornea 120, iris 130, ciliary bodies 140, trabecular meshwork 150, and Schlemm's canal 160 are pictured. Anatomically, the anterior chamber of the eye includes the structures that cause glaucoma. Aqueous fluid is produced by the ciliary bodies 140 that lie beneath the iris 130 and adjacent to the lens 110 in the anterior chamber. This aqueous humor washes over the lens 110 and iris 130 and flows to the drainage system located in the angle of the anterior chamber. The angle of the anterior chamber, which extends circumferentially around the eye, contains structures that allow the aqueous humor to drain. The first structure, and the one most commonly implicated in glaucoma, is the trabecular meshwork 150. The trabecular meshwork 150 extends circumferentially around the anterior chamber in the angle. The trabecular meshwork 150 seems to act as a filter, limiting the outflow of aqueous humor and providing a back pressure producing the IOP. Schlemm's canal 160 is located beyond the trabecular meshwork 150. Schlemm's canal 160 has collector channels that allow aqueous humor to flow out of the anterior chamber. The two arrows in the anterior chamber of Figure 1 show the flow of aqueous humor from the ciliary bodies 140, over the lens 110, over the iris 130, through the trabecular meshwork 150, and into Schlemm's canal 160 and its collector channels.

In glaucoma patients, IOP can vary widely during a 24 hour period. Generally, IOP is highest in the early morning hours before medication is administered upon waking. Higher pressures damage the optic nerve and can lead to blindness. Accordingly, it would be desirable to measure IOP over time in order to assess the efficacy of various treatments. The present invention provides an IOP measuring device.

30

SUMMARY OF THE INVENTION

In one embodiment consistent with the principles of the present invention, the present invention is an implantable intraocular pressure sensor system that has a sealed geometric shape with an internal pressure at a first value. A strain gauge wire is embedded in a surface of the sealed geometric shape. When the surface is deflected a measured resistance of the strain gauge wire indicates an intraocular pressure.

In another embodiment consistent with the principles of the present invention, the present invention is an implantable intraocular pressure sensor system that has a sealed geometric shape with an internal pressure at a first value. A strain gauge wire is embedded in a surface of the sealed geometric shape. When the surface is deflected by intraocular pressure, a measured resistance of the strain gauge wire indicates the intraocular pressure. The system also has a processor coupled to a power source and memory. The processor is configured to read the measured resistance and write values corresponding to intraocular pressure to the memory.

10

It is to be understood that both the foregoing general description and the following detailed description are exemplary and explanatory only and are intended to provide further explanation of the invention as claimed. The following description, as well as the practice of the invention, set forth and suggest additional advantages and purposes of the invention.

15

BRIEF DESCRIPTION OF THE DRAWINGS

The accompanying drawings, which are incorporated in and constitute a part of this specification, illustrate several embodiments of the invention and together with the description, serve to explain the principles of the invention.

20

Figure 1 is a diagram of the front portion of an eye.

Figure 2 is a block diagram of an IOP measuring system according to the principles of the present invention.

25

Figure 3 is a perspective view of an IOP sensor according to the principles of the present invention.

30

Figure 4 is a top view of an IOP sensor according to the principles of the present invention.

Figure 5 is a representation of a strain gauge wire according to the principles of the present invention.

35

Figure 6 is a top view of an IOP sensor according to the principles of the present invention.

DETAILED DESCRIPTION OF THE PREFERRED EMBODIMENTS

Reference is now made in detail to the exemplary embodiments of the invention, examples of which are illustrated in the accompanying drawings. Wherever possible, the same reference numbers are used throughout the drawings to refer to the same or like parts.

Figure 2 is a block diagram of an IOP measuring system 200 according to the principles of the present invention. In Figure 2, the IOP measuring system includes power source 205, IOP sensor 210, processor 215, memory 220, data transmission module 225, and optional speaker 230.

Power source 205 is typically a rechargeable battery, such as a lithium ion or lithium polymer battery, although other types of batteries may be employed. In addition, any other type of power cell is appropriate for power source 205. Power source 205 provides power to the system 200, and more particularly to processor 215. Power source can be recharged via an RFID link or other type of magnetic coupling.

Processor 215 is typically an integrated circuit with power, input, and output pins capable of performing logic functions. In various embodiments, processor 215 is a targeted device controller. In such a case, processor 215 performs specific control functions targeted to a specific device or component, such as a data transmission module 225, speaker 230, power source 205, or memory 220. In other embodiments, processor 215 is a microprocessor. In such a case, processor 215 is programmable so that it can function to control more than one component of the device. In other cases, processor 215 is not a programmable microprocessor, but instead is a special purpose controller configured to control different components that perform different functions.

Memory 220 is typically a semiconductor memory such as NAND flash memory. As the size of semiconductor memory is very small, and the memory needs of the system 200 are small, memory 220 occupies a very small footprint of system 200. Memory 220 interfaces with processor 215. As such, processor 215 can write to and read from memory 220. For example, processor 215 can be configured to read data from the IOP sensor 210 and write that data to memory 220. In this manner, a series of IOP readings can be stored in memory 220. Processor 215 is also capable of performing other basic memory functions, such as erasing or overwriting memory

220, detecting when memory 220 is full, and other common functions associated with managing semiconductor memory.

5 Data transmission module 225 may employ any of a number of different types of data transmission. For example, data transmission module 225 may be active device such as a radio. Data transmission module 225 may also be a passive device such as the antenna on an RFID tag. In this case, an RFID tag includes memory 220 and data transmission module 225 in the form of an antenna. An RFID reader can then be placed near the system 200 to write data to or read data from memory 220.
10 Since the amount of data typically stored in memory 220 is likely to be small (consisting of IOP readings over a period of time), the speed with which data is transferred is not crucial. Other types of data that can be stored in memory 220 and transmitted by data transmission module 225 include, but are not limited to, power source data (e.g. low battery, battery defect), speaker data (warning tones, voices),
15 IOP sensor data (IOP readings, problem conditions), and the like.

Optional speaker 230 provides a warning tone or voice to the patient when a dangerous condition exists. For example, if IOP is at a level that is likely to lead to damage or presents a risk to the patient, speaker 230 may sound a warning tone to
20 alert the patient to seek medical attention or to administer eye drops. Processor 215 reads IOP measurements from IOP sensor 210. If processor 215 reads one or a series of IOP measurements that are above a threshold, then processor 215 can operate speaker 230 to sound a warning. The threshold can be set and stored in memory 220. In this manner, an IOP threshold can be set by a doctor, and when exceeded, a
25 warning can be sounded.

Alternatively, data transmission module may be activated to communicate an elevated IOP condition to a secondary device such as a PDA, cell phone, computer, wrist watch, custom device exclusively for this purpose, remote accessible data
30 storage site (e.g. an internet server, email server, text message server), or other electronic device. In one embodiment, a personal electronic device uploads the data to the remote accessible data storage site (e.g. an internet server, email server, text message server). Information may be uploaded to a remote accessible data storage site so that it can be viewed in real time, for example, by medical personnel. In this
35 case, the secondary device may contain the speaker 230. For example, in a hospital setting, after a patient has undergone glaucoma surgery and had system 200 implanted, a secondary device may be located next to the patient's hospital bed. Since IOP fluctuations are common after glaucoma surgery (both on the high side and

on the low side which is also a dangerous condition), processor 215 can read IOP measurements made by an implanted IOP sensor 210. If processor 215 reads an unsafe IOP condition, data transmission module 225 can alert the patient and medical staff via speaker 230 or by transmitting the unsafe readings to a secondary device.

5

Such a system is also suitable for use outside a hospital setting. For example, if an unsafe IOP condition exists, processor 215 can operate speaker 230 to sound an audible warning. The patient is then alerted and can seek medical attention. The warning can be turned off by a medical professional in a number of ways. For example, when data transmission module 225 is an RFID tag, an RFID link can be established between an external device and system 200. This external device can communicate with system 200 to turn off the speaker 230. Alternatively, an optical signal may be read by system 200. In this case, data transmission module 225 has an optical receptor that can receive a series of light pulses that represent a command – such as a command to turn off speaker 230.

10
15

System 200 is preferably in a small, implantable, integrated package. As such, all of the components of system 200 can be built on a substrate, such as a semiconductor wafer, by any of a number of different processes.

20

Figure 3 is a perspective view of an IOP sensor according to the principles of the present invention. In Figure 3, IOP sensor 210 is a sealed cube with a strain gauge wire 310 embedded in top surface 305. Lead wires 315 allow a measurement to be taken that corresponds to IOP. The sealed cube has an internal pressure of about 0 psig or generally atmospheric pressure (although other pressures can be used as well, 0 psig is used as an example here). When IOP sensor 210 is exposed to the eye's aqueous humor, top surface 305 deflects inward because the eye's aqueous humor is at about 1/3 psig. In other words, when placed in the eye, there is a small pressure difference between the inside of the cube and the outside of the cube. Since the pressure inside the cube is lower than the pressure outside the cube, the top surface 305 deflects inward. Embedded strain gauge wire 310 is then stretched. As strain gauge wire 310 is stretched, its cross sectional area is reduced which causes a change in the measurable resistance of strain gauge wire 310. This change in resistance is measured via lead wires 315. In this manner, when a voltage is applied across lead wires 315, current can be measured to calculate the resistance of the strain gauge wire 310. Pressure can then be correlated to resistance so that a resistance measurement indicates a magnitude of IOP. While shown as a cube, IOP sensor may be other geometric shapes that allow for deflection of strain gauge wire 310.

25

30

35

The pressure inside the cube of IOP sensor 210 is determined during the manufacturing process and can be about 0 psig. The cube of IOP sensor 210 can be filled with any of a number of a variety of different gases, such as nitrogen, argon, sulfur hexafluoride, or the like.

For IOP measurements, calibrating the IOP sensor 210 is generally not critical. In most cases, it is the change in IOP that present problems for a glaucoma patient. Since a change in the resistance of strain gauge wire 310 can be correlated with a magnitude of IOP, a change in IOP can be easily detected. Generally, a series of resistance measurements taken over time corresponds to the relative magnitude of IOP over time. More precise calibration of IOP can be done in a doctor's office, for example, by measuring IOP in a traditional manner and correlating that measurement to a measured resistance of strain gauge wire 310.

IOP sensor 210 can be manufactured via any of a number of different methods. For example, in a MEMS-based method, IOP sensor 210 is built in layers. In this manner, layers of a biocompatible, flexible, electrically insulating material are deposited to build IOP sensor 210. When the top surface 305 is deposited, strain gauge wire 310 is embedded in the top surface 305. Other vapor deposition methods, such as those used in the semiconductor industry, may also be employed.

Figure 4 is a top view of an IOP sensor according to the principles of the present invention. In Figure 4, strain gauge wire 310 is embedded in top surface 305 of the cube. Lead wires 315 are electrically coupled to strain gauge wire 310. While shown as a straight length of wire, strain gauge wire 310 may assume any configuration. For example, strain gauge wire 310 may be coiled, bent, looped, or assume a pattern on top surface 305. As top surface 305 is deflected inward, the length of strain gauge wire 310 changes resulting in a measurable change in resistance.

Figure 5 is a representation of a strain gauge wire according to the principles of the present invention. In Figure 5, strain gauge wire 310 is in a deflected position. The arrow represents the external pressure on IOP sensor 210. Since the external pressure is always greater than the internal pressure, strain gauge wire 310 will always be in some state of deflection.

Figure 6 is a top view of an IOP sensor according to the principles of the present invention. In Figure 6, strain gauge wire 310 is located in a track or groove 605 in top surface 305. This track or groove 605 assists in the manufacturability of IOP sensor 210. Since embedding strain gauge wire 310 in top surface 305 may be difficult depending on the type of manufacturing process used, a track or groove 605 may be manufactured in top surface 305 and a strain gauge wire 310 later placed in track or groove 605.

In another embodiment of the present invention, an array of IOP sensors 210 (shown in Figs, 3 & 4) can be used together. In this configuration, more than one IOP sensor 210 is attached to a substrate and then implanted in the eye. Using more than one IOP sensor 210 allows for redundancy and more accurate measurement of IOP. As the number of IOP sensors 210 in array increases, the statistical variance of the resulting IOP measurement decreases (and thus accuracy increases).

15

From the above, it may be appreciated that the present invention provides a system measuring IOP. The present invention provides an IOP sensor and associated peripherals. The present invention is illustrated herein by example, and various modifications may be made by a person of ordinary skill in the art.

20

Other embodiments of the invention will be apparent to those skilled in the art from consideration of the specification and practice of the invention disclosed herein. It is intended that the specification and examples be considered as exemplary only, with a true scope and spirit of the invention being indicated by the following claims.

25

What is claimed is:

1. An implantable intraocular pressure sensor system comprising:
a sealed geometric shape with an internal pressure at a first value, the sealed
5 geometric shape having a surface; and
a strain gauge wire embedded in the surface;
wherein when the surface is deflected a measured resistance of the strain
gauge wire indicates an intraocular pressure condition.
- 10 2. The pressure sensor system of claim 1 further comprising:
a pair of lead wires, the pair of lead wires coupled to the strain gauge wire.
3. The pressure sensor system of claim 1 further comprising:
a processor;
15 a power source coupled to the processor; and
a memory coupled to the processor;
wherein the processor is configured to read the measured resistance.
4. The pressure sensor system of claim 3 wherein the processor writes values
20 corresponding to intraocular pressure to the memory.
5. The pressure sensor system of claim 3 further comprising:
a data transmission module coupled to the processor.
- 25 6. The pressure sensor system of claim 5 wherein the data transmission module
further comprises a radio.
7. The pressure sensor system of claim 5 wherein the data transmission module
further comprises an RFID tag.
30
8. The pressure sensor system of claim 7 wherein data is transferred from the
memory over an RFID link.
9. The pressure sensor system of claim 5 wherein the data transmission module
35 transfers data from the memory to an external device.

10. The pressure sensor system of claim 3 further comprising:
a speaker coupled to the processor; wherein the speaker sounds a warning when intraocular pressure is outside a safe range.
- 5 11. The pressure sensor system of claim 1 wherein the sealed geometric shape is generally cubic.

12. An implantable intraocular pressure sensor system comprising:
an IOP sensor comprising:
a sealed geometric shape with an internal pressure at a first value, the
sealed geometric shape having a surface; and
5 a strain gauge wire embedded in the surface;
wherein when the surface is deflected by an intraocular pressure, a
measured resistance of the strain gauge wire indicates the intraocular pressure;
a processor;
a power source coupled to the processor; and
10 a memory coupled to the processor;
wherein the processor is configured to read the measured resistance and write
values corresponding to intraocular pressure to the memory.
13. The pressure sensor system of claim 12 further comprising:
15 a data transmission module coupled to the processor.
14. The pressure sensor system of claim 13 wherein the data transmission module
further comprises a radio.
- 20 15. The pressure sensor system of claim 13 wherein the data transmission module
further comprises an RFID tag.
16. The pressure sensor system of claim 15 wherein data is transferred from the
memory over an RFID link.
25
17. The pressure sensor system of claim 13 wherein the data transmission module
transfers data from the memory to an external device.
18. The pressure sensor system of claim 12 further comprising:
30 a speaker coupled to the processor;
wherein the speaker sounds a warning when intraocular pressure is outside a
safe range.
19. The pressure sensor system of claim 12 wherein the sealed geometric shape is
35 generally cubic.

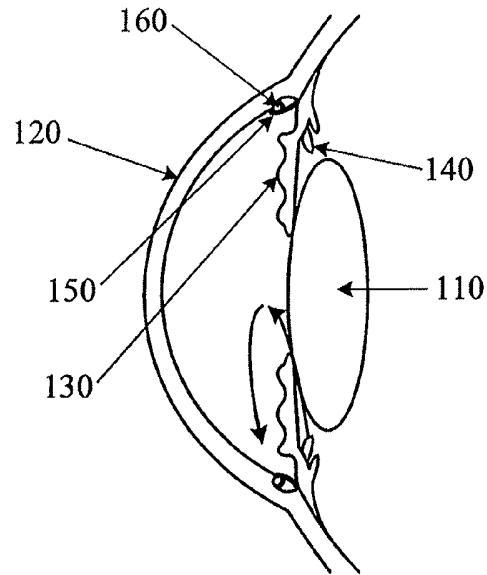

Fig. 1

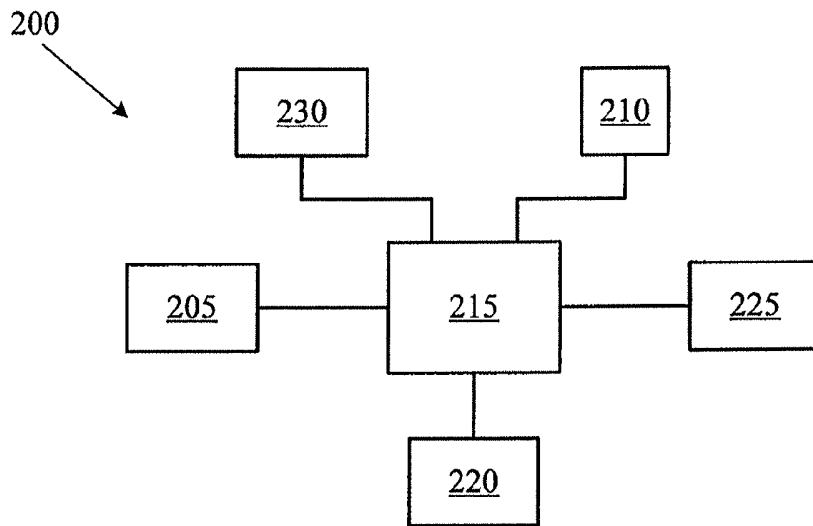

Fig. 2

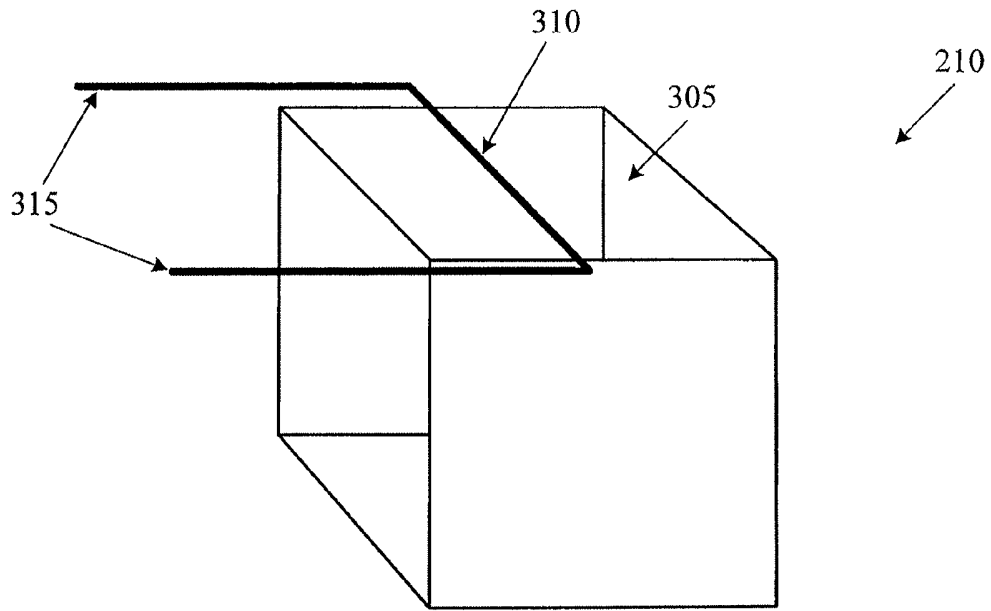

Fig. 3

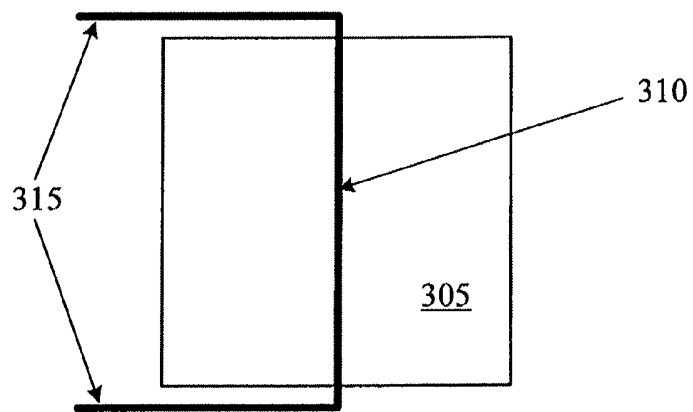

Fig. 4

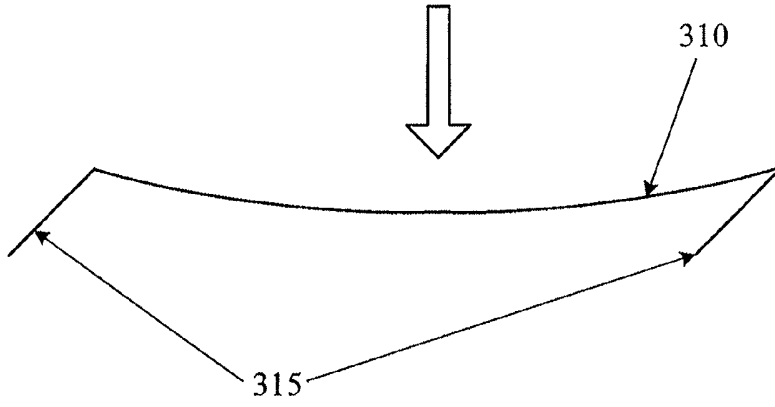

Fig. 5

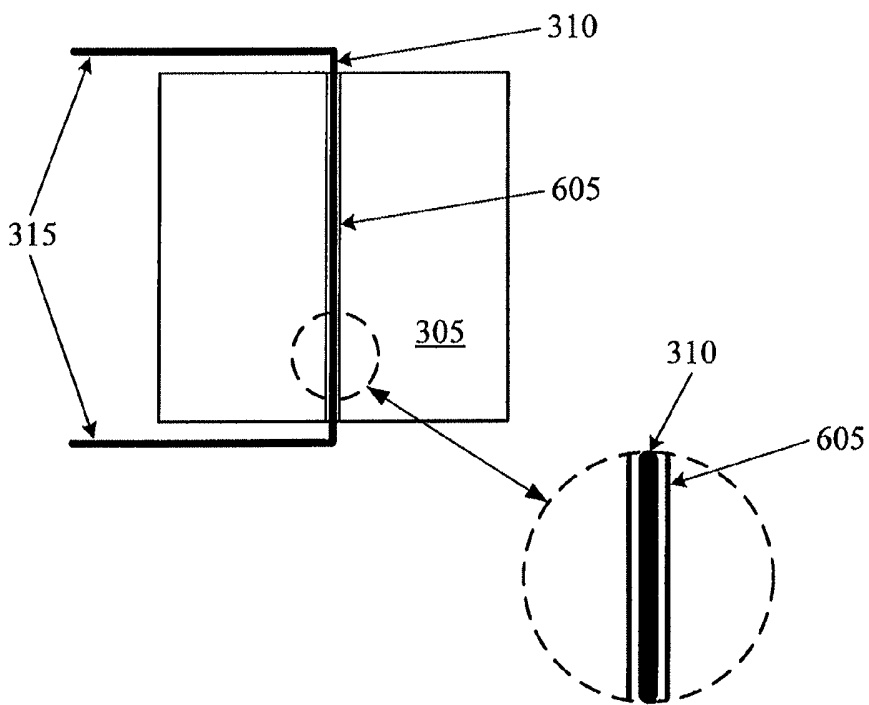

Fig. 6