

(19) World Intellectual Property Organization
International Bureau



(43) International Publication Date
11 April 2002 (11.04.2002)

PCT

(10) International Publication Number
WO 02/30020 A2

(51) International Patent Classification⁷: H04B 10/207

(21) International Application Number: PCT/US01/31032

(22) International Filing Date: 4 October 2001 (04.10.2001)

(25) Filing Language: English

(26) Publication Language: English

(30) Priority Data:

60/237,894	4 October 2000 (04.10.2000)	US
60/244,052	26 October 2000 (26.10.2000)	US
60/243,978	27 October 2000 (27.10.2000)	US
60/258,837	28 December 2000 (28.12.2000)	US
60/289,112	8 May 2001 (08.05.2001)	US
09/899,410	5 July 2001 (05.07.2001)	US

(71) Applicant: WAVE7 OPTICS, INC. [US/US]; 1075 Windward Ridge Parkway, Suite 170, Alpharetta, GA 30005 (US).

(72) Inventors: FARMER, James, O.; 3602 Preston Court, Lilburn, GA 30047 (US). TIGHE, Thomas, A.; 330

Oakridge Terrace, Alpharetta, GA 30005 (US). WHIT-
TLESEY, Paul, F.; 1061 Secret Trail, Sugar Hill, GA
30518 (US). QUINN, Patrick, W.; 1226 Sunrise Ridge
Drive, Lafayette, CA 94549 (US). KENNY, John, J.;
5590 Trion Cove, Norcross, GA 30092 (US). VELLA,
Emmanuel, A.; 5505 Timson Lane, Alpharetta, GA 30022
(US).

(74) Agent: WIGMORE, Steven, P.; King & Spalding, 191
Peachtree Street, Atlanta, GA 30303-1763 (US).

(81) Designated States (*national*): AE, AG, AL, AM, AT, AU,
AZ, BA, BB, BG, BR, BY, BZ, CA, CH, CN, CO, CR, CU,
CZ, DE, DK, DM, DZ, EC, EE, ES, FI, GB, GD, GE, GH,
GM, HR, HU, ID, IL, IN, IS, JP, KE, KG, KP, KR, KZ, LC,
LK, LR, LS, LT, LU, LV, MA, MD, MG, MK, MN, MW,
MX, MZ, NO, NZ, PH, PL, PT, RO, RU, SD, SE, SG, SI,
SK, SL, TJ, TM, TR, TT, TZ, UA, UG, UZ, VN, YU, ZA,
ZW.

(84) Designated States (*regional*): ARIPO patent (GH, GM,
KE, LS, MW, MZ, SD, SL, SZ, TZ, UG, ZW), Eurasian
patent (AM, AZ, BY, KG, KZ, MD, RU, TJ, TM), European
patent (AT, BE, CH, CY, DE, DK, ES, FI, FR, GB, GR, IE,

[Continued on next page]

(54) Title: SYSTEM AND METHOD FOR COMMUNICATING OPTICAL SIGNALS UPSTREAM AND DOWNSTREAM BETWEEN A DATA SERVICE PROVIDER AND SUBSCRIBERS

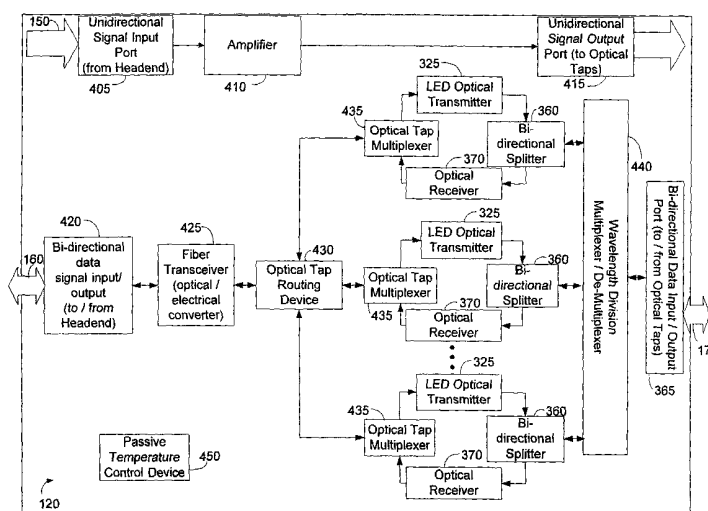

(57) Abstract: An optical fiber network can include an outdoor bandwidth transforming node that can be positioned in close proximity to the subscribers of an optical fiber network. The outdoor bandwidth transforming node does not require active cooling and heating devices that control the temperature surrounding the bandwidth transforming node. The bandwidth transforming node can adjust a subscriber's bandwidth on a subscription basis or on an as-needed basis. The bandwidth transforming node can also offer data bandwidth to the subscriber in preassigned increments. Additionally, the bandwidth transforming node lends itself to efficient upgrading that can be performed entirely on the network side. The bandwidth transforming node can also provide high speed symmetrical data transmission. Further, the bandwidth transforming node can increase upstream and downstream bandwidth and transmission speed by propagating data signals at different wavelengths.



WO 02/30020 A2



IT, LU, MC, NL, PT, SE, TR), OAPI patent (BF, BJ, CF, CG, CI, CM, GA, GN, GQ, GW, ML, MR, NE, SN, TD, TG).

For two-letter codes and other abbreviations, refer to the "Guidance Notes on Codes and Abbreviations" appearing at the beginning of each regular issue of the PCT Gazette.

Published:

— *without international search report and to be republished upon receipt of that report*

**SYSTEM AND METHOD FOR COMMUNICATING OPTICAL SIGNALS
UPSTREAM AND DOWNSTREAM BETWEEN A DATA SERVICE
PROVIDER AND SUBSCRIBERS**

5

STATEMENT REGARDING RELATED APPLICATIONS

The present application is a continuation-in-part of non-provisional patent application entitled, "System and Method for Communicating Optical Signals Between A Data Service Provider and Subscribers," filed on July 5, 2001 and assigned U.S. Application Serial No. 09/899,410; and the present application claims priority to provisional patent application entitled, "Systems to Provide Video, Voice and Data Services via Fiber Optic Cable," filed on October 4, 2000 and assigned U.S. Application Serial No. 60/237,894; provisional patent application entitled, "Systems to Provide Video, Voice and Data services via Fiber Optic Cable - Part 2," filed on October 26, 2000 and assigned U.S. Application Serial No. 60/244,052; provisional patent application entitled, "Systems to Provide Video, Voice and Data services via Fiber Optic Cable - Part 3," filed on December 28, 2000 and assigned U.S. Application Serial No. 60/258,837; provisional patent application entitled, "Protocol to Provide Voice and Data Services via Fiber Optic Cable," filed on October 27, 2000 and assigned U.S. Application Serial No. 60/243,978; and provisional patent application entitled, "Protocol to Provide Voice and Data Services via Fiber Optic Cable-Part 2," filed on May 8, 2001 and assigned U.S. Application Serial No. 60/289,112, the entire contents of which are incorporated by reference.

25 TECHNICAL FIELD

The present invention relates to video, voice, and data communications. More particularly, the present invention relates to a system and method for communicating optical signals between a data service provider and one or more subscribers.

30 BACKGROUND OF THE INVENTION

The increased use of and reliance on communication networks to transmit complex forms of data, such as voice and video data, has resulted in a demand in the marketplace for more bandwidth. Thus, conventional communication architectures

that use coaxial cables are being replaced with communication networks that use only fiber optic cable, since optical fibers can carry a greater amount of data.

Data service providers have long desired Fiber-to-the-home (FTTH) and Fiber-to-the-business (FTTB) optical network architectures. These network architectures are known for their improved signal quality, for the lower system maintenance that they require, and for the longer life of the hardware that is employed in such systems. Though in the past the use of the FTTH and FTTB architectures was considered cost prohibitive, research and development has resulted in improved, cost-effective optical network alternatives.

The passive fiber optic network (PON) is an example of an FTTH architecture that is used in the industry. The PON architecture includes of an all-fiber network (where fiber optic transmission is used from the data service hub to subscribers' homes). In one configuration, optical splitters are used to divide the downstream signal among a plurality of homes, with one or more fiber optic cables connecting each home to the splitter. In another configuration, individual fibers extend from the data service hub directly to individual homes. Though the PON architecture allows for an all-fiber network, several drawbacks remain that make it impractical to implement.

First, in order to overcome the limitations that exist in the number of times an optical signal can be divided with an optical splitter before that signal becomes too weak to use, the PON architecture usually requires too many optical cables to originate at the data service hub. Second, because there is no active signal processing disposed between the data service hub and the subscriber, the maximum distance that can be achieved between the data service hub and a subscriber usually falls within the range of ten to twenty kilometers.

Third, another significant drawback of the PON architecture is the high cost of the equipment needed at the data service hub. For example, many PON architectures support the full service access network (FSAN), which uses the asynchronous transfer mode (ATM) protocol. Complex and expensive equipment is needed to support this protocol.

Fourth, not only is the PON architecture expensive, but it does not lend itself to efficient upgrades. Rather, in order to increase the data speed of the network, conventional and traditional PON architectures require fiber and router ports to be added during an actual physical reconfiguration of the network.

5 Finally, conventional PON architectures typically only support speeds up to 622 Megabits per second in the downstream direction and maximum speeds of 155 Megabits per second in the upstream direction. The term "downstream" can define a communication direction where a data service hub originates data signals that are sent downwards towards subscribers of an optical network. Conversely, the term
10 "upstream" can define a communication direction where subscribers originate data signals that are sent upwards towards a data service hub of an optical network. Such unbalanced communication speeds between the upstream and downstream communication directions (referred to as asymmetrical bandwidth) is undesirable because it severely limits the amount of information that can be transferred from a
15 subscriber to a data service hub.

As a result of the drawbacks of the PON architecture discussed above, a conventional hybrid FTTH/ hybrid fiber-coax (HFC) architecture is commonly used by many cable television systems. In this FTTH/HFC architecture, an active signal source is placed between the data service hub and the subscriber. Typically, a router
20 is used as the active signal source. The router has multiple data ports that are designed to support individual subscribers. More specifically, an optical fiber connects each data port of the router to each subscriber. The connectivity between data ports and optical subscribers yields a very fiber-intensive last mile. It is noted that the terms "last mile" and "first mile" are generic terms used to describe the last
25 portion of an optical network that connects to subscribers.

In addition to the high number of optical cables originating from the router, the FTTH/HFC architecture requires that the optical signals be converted to electrical, radio frequency signals before they are propagated along traditional coaxial cables to the subscriber. Because radio frequency (RF) amplifiers are needed between the
30 subscriber and the data service hub (RF amplifiers are typically needed every one to three kilometers in a coaxial-type system), this adds to the overall cost of the system.

Additionally, because the FTTH/HFC architecture merely combines an optical network with an electrical network where both networks run independently of one another, high maintenance costs can result.

5 An additional drawback to the FTTH/HFC architecture is that the router requires a protected environment that occupies a significant amount of space. More specifically, it requires an environmentally controlled cabinet that must house the router and related equipment at an optimum temperature. In order to maintain this optimum temperature, the environmental cabinet typically includes active temperature control devices for heating and cooling the cabinet. These cooling and heating units
10 consume power and are needed to maintain an operating temperature in all types of geographic areas and in all types of weather.

Although another conventional hybrid fiber coax (HFC) architecture exists that employs an active signal source between the data service hub and the subscriber that does not require a temperature-controlled environmental cabinet (as described
15 above), this active signal source merely converts optical information signals to electrical information signals. More specifically, the active signal source in the HFC architecture converts downstream optical signals into electrical signals and upstream electrical signals into optical signals. Thus, because the conventional HFC architecture relies upon coaxial cable to transmit the electrical signals in the last mile
20 of the HFC network, it still requires numerous RF amplifiers on the coaxial cable side of the network in order to ensure sufficient signal strength.

Additionally, the conventional HFC architecture also requires additional communication devices to support the data signals that propagate along the optical fibers between the active signal source and the data service hub. For example,
25 because the conventional HFC architecture typically supports telephony service, it uses equipment known generically as host digital terminal (HDT). The HDT can include RF interfaces on the cable side and interfaces to either a telephone switch or to a cable carrying signals to a switch on the other side. Similarly, the data service hub of a conventional HFC architecture can further include a cable modem
30 termination system (CMTS). The CMTS provides low level formatting and

transmission functions for the data transmitted between the data service hub and the subscriber.

In addition to a CMTS, the conventional HFC architecture at the data service hub typically includes several modulators, or miniature television transmitters. Each modulator can convert video signals received from satellites to an assigned channel (frequency) for transmission to subscribers. Additionally, signal processors and other devices are used to collect the entire suite of television signals to be sent to subscribers. Typically, in a conventional HFC architecture, up to seventy-eight or more such modulators or processors will exist with their supporting equipment to serve the analog TV tier. Similar equipment will be used to serve the digital video tier.

Because HFC architecture uses CMTS, it cannot support symmetrical bandwidth. That is, the bandwidth of the conventional HFC architecture is typically asymmetrical because of the use of the data over cable service interface specification (DOCSIS). The nature of the DOCSIS standard is that it limits the upstream bandwidth available to subscribers. This can be a direct result of the limited upstream bandwidth available in an HFC plant. This is undesirable for subscribers who need to transmit more complex data for bandwidth intensive services such as home servers or the exchange of audio or video files over the Internet.

Another variation of the conventional HFC architecture exists in the marketplace where the CMTS can be part of the active signal source disposed between the data service hub and the subscriber. Though this variation of the conventional HFC architecture enables the active signal source to perform some processing, the output of the active signal source in this architecture is still radio frequency energy and is propagated along coaxial cables.

Accordingly, there is a need in the art for a system and method for communicating optical signals between a data service provider and a subscriber that eliminates the use of coaxial cables and the related hardware and software necessary to support the data signals propagating along the coaxial cables. There is also a need in the art for a system and method for communicating optical signals between a data service hub and a subscriber that supports high-speed symmetrical data transmission.

In other words, there is a need in the art for an all-fiber optical network and method that can propagate the same bit rate downstream and upstream between a data service hub and a network subscriber. Further, there is also a need in the art for an optical network system and method that can service a larger number of subscribers while
5 reducing the number of connections at the data service hub.

There is also a need in the art for an active signal source that can be disposed between a data service hub and a subscriber that can be designed to withstand outdoor environmental conditions and that can be designed to hang on a strand or fit in a pedestal similar to conventional cable TV equipment that is placed within a last mile
10 of a communications network. A further need exists in the art for a system and method for receiving at least one gigabit or faster Ethernet communications in optical form from a data service hub and partition or apportion this optical bandwidth into distribution groups of a predetermined number. There is a further need in the art for a system and method that can allocate additional or reduced bandwidth based upon the
15 demand of one or more subscribers on an optical network. Another need exists in the art for an optical network system that lends itself to efficient upgrading that can be performed entirely on the network side.

In other words, there is a need in the art for an optical network system that allows upgrades to hardware to take place in locations between and within a data
20 service hub and an active signal source disposed between the data service hub and a subscriber. Another need exists in the art for an optical network that can increase information traffic carried by optical waveguides to and from subscribers of the optical network.

25 SUMMARY OF THE INVENTION

The present invention is generally drawn to a system and method for efficient propagation of data and broadcast signals over an optical fiber network. More specifically, the present invention is generally drawn to an optical network architecture that can include an outdoor bandwidth transforming or processing node
30 that can be positioned in close proximity to the subscribers of an optical waveguide network. For example, the outdoor bandwidth transforming node can be designed to

withstand outdoor environmental conditions and can be designed to hang on a strand or fit in a pedestal similar to conventional cable TV equipment that is placed within “the last mile” of an optical network architecture.

5 Unlike conventional electronic cable TV equipment or conventional optical bandwidth transforming nodes, the bandwidth transforming node can receive gigabit Ethernet communications in optical form from the data service hub and partition this optical bandwidth into distribution groups of a predetermined number. In one exemplary embodiment, the bandwidth transforming node can partition the optical bandwidth into distribution groups comprising at least six groups of at least sixteen
10 subscribers. However, other partitioning sizes are not beyond the scope of the present invention.

Using an appropriate protocol in combination with a partitioning architecture, the bandwidth transforming node can allocate additional or reduced bandwidth based upon the demand of one or more subscribers. That is, the bandwidth transforming
15 node can adjust a subscriber’s bandwidth on a subscription basis or on an as-needed basis. The bandwidth transforming node can offer data bandwidth to the subscriber in preassigned increments. For example, the bandwidth transforming node can offer a particular subscriber or groups of subscribers bandwidth in units of 1, 2, 5, 10, 20, 50, 100, and 450 Megabits per second (Mb/s).

20 In addition to offering bandwidth in preassigned increments, the bandwidth transforming node lends itself to efficient upgrading that can be performed entirely on the network side. In other words, upgrades to the hardware forming the bandwidth transforming node can take place in locations between and within the data service hub and the bandwidth transforming node. This means that the subscriber side of the
25 network can be left entirely intact during an upgrade to the bandwidth transforming node or data service hub or both.

The bandwidth transforming node can also provide data symmetry at higher speeds. In other words, the bandwidth transforming node can propagate the same bit rates downstream and upstream between the data service hub and the network
30 subscribers. Further, the bandwidth transforming node can also serve a larger number of subscribers while reducing the number of connections at the data service hub.

The flexibility and diversity of the bandwidth transforming node can be attributed to at least a few components. The bandwidth transforming node can comprise an optical tap routing device that is coupled to one or more optical tap multiplexers. The optical tap routing device can manage the interface with the data service hub data and can route or divide the data service hub data according to individual optical tap multiplexers that generate data for specific optical taps. The optical taps, in turn, service preassigned groups of subscribers.

The optical tap routing device can determine which optical tap multiplexer is to receive a downstream data signal, or identify which of the plurality of optical taps originated an upstream data signal. Each optical tap multiplexer can format data and implement the protocol required to send and receive data from each individual subscriber connected to a respective optical tap (as will be discussed below).

The bandwidth transforming node can further comprise one or more wavelength division multiplexers and demultiplexers. Each wavelength division multiplexer (WDM) can select one or more wavelengths of optical bandwidth originating from a respective optical tap multiplexer. Each WDM can then combine the one or more wavelengths of optical bandwidth together and feed them into a single optical waveguide. In this way, one optical waveguide can service a number of individual optical taps that can correspond to the number of optical tap multiplexers present in the bandwidth transforming node. The bandwidth transforming node can also support unidirectional optical signals originating from the data service hub. The unidirectional optical signals can comprise broadcast video or other similar RF signals.

The bandwidth transforming node is but one part of the present invention. The present invention also comprises an efficient coupler between the bandwidth transforming node and a respective subscriber, the efficient coupler being referred to as an optical tap. The optical tap can divide data signals between a plurality of subscribers and can be capable of managing optical signals of multiple wavelengths. The optical tap can also route signals to other optical taps that are downstream relative to a respective optical tap. The optical tap can also connect to a limited or small

number of optical waveguides so that high concentrations of optical waveguides are not present at any particular optical tap.

Each optical tap can comprise one or more spectral slicers. Each spectral slicer can be complementary to a respective optical tap multiplexer present in a bandwidth transforming node. That is, each spectral slicer can filter or separate optical energy of a wavelength region that can comprise the wavelength region generated by a respective multiplexer in a bandwidth transforming node. In this way, upstream and downstream optical data signals can propagate simultaneously from optical taps to the data service hub without regard to when other optical signals are being propagated upstream from other optical taps that utilize the same optical waveguide. Each optical tap can also support downstream unidirectional optical signals, such as radio frequency (RF) signals, originating from the data service hub.

BRIEF DESCRIPTION OF THE DRAWINGS

Fig. 1 is a functional block diagram of some core components of an exemplary optical network architecture according to the present invention.

Fig. 2 is a functional block diagram illustrating an exemplary optical network architecture for the present invention.

Fig. 3 is a functional block diagram illustrating an exemplary data service hub of the present invention.

Fig. 4 is a functional block diagram illustrating an exemplary outdoor bandwidth transforming node according to the present invention.

Fig. 5 is a functional block diagram illustrating another exemplary embodiment of an outdoor bandwidth transforming node according to the present invention.

Fig. 6 is a functional block diagram illustrating an optical tap connected to an optical subscriber interface by a single optical waveguide according to one exemplary embodiment of the present invention.

Fig. 7 is a functional block diagram illustrating another optical tap connected to a subscriber interface by both an optical waveguide and a wire conductor according to another exemplary embodiment of the present invention.

Fig. 8 is a functional block diagram illustrating another optical tap connected to a bandwidth transforming node by two optical waveguides according to another exemplary embodiment of the present invention.

Fig. 9 is a functional block diagram illustrating another optical tap
5 connected to a bandwidth transforming node by two optical waveguides according to another exemplary embodiment of the present invention.

Fig. 10 is a functional block diagram illustrating another optical tap connected to a bandwidth transforming node by three optical waveguides according to another exemplary embodiment of the present invention.

10 Fig. 11 is a functional block diagram illustrating yet another optical tap connected to a bandwidth transforming node by three optical waveguides according to another exemplary embodiment of the present invention.

Figs. 12A-12C illustrate the operation of spectral slicers that are present within optical taps of the present invention.

15 Fig. 13 illustrates the operation of transmitters and receivers disposed within an outdoor bandwidth transforming node and the operation of bandpass filters that may be disposed within spectral slicers forming optical taps of the present invention.

20 Fig. 14 illustrates the composite pass band of all filters illustrated in Fig. 13.

Fig. 15 is a logic flow diagram illustrating an exemplary embodiment of a method for processing unidirectional and bi-directional data signals within a bandwidth transforming node of the present invention.

25 Fig. 16 is a logic flow diagram illustrating an exemplary process for handling downstream data signals within a bandwidth transforming node of the present invention.

Fig. 17 is a logic flow diagram illustrating an exemplary process for handling upstream data signals within an exemplary bandwidth transforming node of the present invention.

Fig. 18 is a logic flow diagram illustrating the processing of unidirectional and bi-directional data signals within an optical tap according to the present invention.

Fig. 19 is a logic flow diagram illustrating the processing of unidirectional and bi-directional data signals within a subscriber interface of the present invention.

DETAILED DESCRIPTION OF EXEMPLARY EMBODIMENTS

The present invention may be embodied in hardware or software or a combination thereof disposed within an optical network. The present invention can comprise a bandwidth transforming node disposed between a data service hub and a subscriber that can allocate additional or reduced bandwidth based upon the demand of one or more subscribers. The present invention can support one gigabit or faster Ethernet communications in optical form to and from the data service hub and partition or apportion this optical bandwidth into distribution groups of a predetermined number. The present invention allows bandwidth to be offered to subscribers in pre-assigned increments. The flexibility and diversity of the present invention can be attributed to a few components.

The bandwidth transforming node of the present invention can comprise an optical tap routing device that is coupled to one or more tap multiplexers. The optical tap routing device can assign multiple subscribers to a single port that receives downstream optical signals from a data service hub. The bandwidth transforming node of the present invention can comprise off-the-shelf hardware to generate optical signals. For example, the LED optical transmitters of the present invention (as will be discussed below) can comprise one or more of the Volgatech SLD series diodes or the SLD-56-MP from Superlum, Ltd. The present invention can also comprise efficient couplers, such as optical taps, between the bandwidth transforming node and a respective subscriber optical interface.

The optical tap can divide optical signals among a plurality of subscribers and can be simple in its design. The optical tap can connect to a limited number of optical waveguides at a point remote from the bandwidth transforming node so that high

concentrations of optical waveguides at the bandwidth transforming node can be avoided.

Referring now to the drawings, in which like numerals represent like elements throughout the several Figures, aspects of the present invention and the illustrative operating environment will be described. Figure 1 is a functional block diagram illustrating an exemplary optical network architecture **100** according to the present invention. The exemplary optical network architecture **100** comprises a data service hub **110** (also known by those skilled in the art as a "headend"), that is connected to outdoor bandwidth transforming nodes **120**. The bandwidth transforming nodes **120**, in turn, are connected to one or more optical taps **130**. The optical taps **130** can be connected to a plurality of subscriber optical interfaces **140**. Between respective components of the exemplary optical network architecture **100** are optical waveguides, such as optical waveguides **150, 160, 165, 170, 180, 185, 190, and 195**. The optical waveguides **150-195** are illustrated by arrows where the arrowheads of the arrows illustrate exemplary directions of data flow between respective components of the illustrative and exemplary optical network architecture **100**. While only an individual bandwidth transforming node **120**, an individual optical tap **130**, and an individual subscriber optical interface **140** are illustrated in Figure 1, as will become apparent from Figure 2 and its corresponding description, a plurality of bandwidth transforming nodes **120**, optical taps **130**, and subscriber optical interfaces **140** can be employed without departing from the scope and spirit of the present invention. Typically, in many of the exemplary embodiments of the present invention, multiple subscriber optical interfaces **140** are connected to one or more optical taps **130**.

In one exemplary embodiment of the present invention, two optical waveguides **150** and **160** (that can comprise optical fibers) can propagate optical signals from the data service hub **110** to the outdoor bandwidth transforming node **120**. It is noted that the term "optical waveguide" used in the present application can apply to optical fibers, planar light guide circuits, and fiber optic pigtails and other like optical waveguides.

A first optical waveguide **150** (also hereinafter referred to as a "broadcast waveguide") can carry broadcast video and other signals. The broadcast signals are

carried as analog and digital modulated radio frequency carriers. The signals can be carried in a traditional cable television format, where the broadcast signals are modulated onto carriers, which in turn, modulate an optical transmitter (not shown in Fig. 1) in the data service hub **110**. A second optical waveguide **160** (also hereinafter referred to as a "targeted services waveguide") can carry downstream targeted services (such as data and telephone services) as baseband digital signals to be delivered to one or more subscriber optical interfaces **140**. In addition to carrying subscriber-specific optical signals, the targeted services waveguide **160** can propagate internet protocol broadcast packets, as is understood by those skilled in the art. Additionally, the targeted services waveguide **160** can transport data signals upstream from the bandwidth transforming node **120** to the data service hub **110**. The optical signals propagated along the targeted services waveguide **160** can comprise data and telephone services received from one or more subscribers or IP broadcast packets, as is understood by those skilled in the art.

An upstream optical waveguide **165** is illustrated with dashed lines to indicate that it is merely an option or part of one exemplary embodiment according to the present invention. In other words, the upstream optical waveguide **165** can be removed. In one exemplary embodiment, an optical waveguide **160** propagates optical signals in both the upstream and downstream directions as is illustrated by the double arrows depicting that optical waveguide **160**. In such an exemplary embodiment where the optical waveguide **160** propagates bi-directional optical signals, only two optical waveguides **150**, **160** would be needed to support the optical signals propagating between the bandwidth transforming node **120** and the data service hub **110**. In contrast, where the optical waveguide **160** propagates optical signals in only the downstream direction, the additional dashed optical waveguide **165** would be needed to propagate signals in the upstream direction between the bandwidth transforming node **120** and the data service hub **110**.

Another upstream optical waveguide **180** is illustrated with dashed lines to indicate that it is merely an option or part of one exemplary embodiment according to the present invention. In other words, the dashed optical waveguide **180** can be removed. In another exemplary embodiment, an optical waveguide **170** propagates

optical signals in both the upstream and downstream directions as is illustrated by the double arrows depicting that optical waveguide 170. In such an exemplary embodiment where the optical waveguide 170 propagates bi-directional optical signals, only two optical waveguides 150, 170 would be needed to support the optical signals propagating between the bandwidth transforming node 120 and the optical tap 130. In contrast, where the optical waveguide 170 propagates optical signals in only the downstream direction, the additional dashed optical waveguide 180 would be needed to propagate signals in the upstream direction between the bandwidth transforming node 120 and the optical tap 130.

Similarly, additional optical waveguides 185, 195 are illustrated with dashed lines to indicate that they are merely an option or part of another exemplary embodiment according to the present invention. In other words, the additional optical waveguides 185, 195 can be removed. In one exemplary embodiment, one optical waveguide 190 propagates optical signals in both the upstream and downstream directions as is illustrated by the double arrows depicting the optical waveguide 190. In such an exemplary embodiment where the optical waveguide 190 propagates bi-directional optical signals, only one optical waveguide 190 could support the optical signals propagating between the optical tap 130 and the subscriber optical interface 140.

In contrast, in another exemplary embodiment, where two waveguides are needed between the optical tap 130 and the subscriber optical interface 140, the optical waveguide 185 is used and propagates optical signals in the downstream direction, and optical waveguide 190 is used and propagates signals in both the downstream and the upstream directions. Similarly, in another exemplary embodiment, where three waveguides are needed between the optical tap 130 and the subscriber optical interface 140, optical waveguide 185 is used to propagate signals in the downstream direction, optical waveguide 190 is used to propagate signals in the downstream direction, and optical waveguide 195 is used to propagate signals in the upstream direction. Last, in another exemplary embodiment, where two optical waveguides are required between optical tap 130 and subscriber optical interface 140, the signals from optical waveguide 185 and optical waveguide 190 are multiplexed

together (not shown) and are propagated downstream on optical waveguide **190**, and optical waveguide **195** is used to propagate signals in the upstream direction.

The outdoor bandwidth transforming node **120** can be designed to withstand outdoor environmental conditions and can be designed to hang on a strand or fit in a pedestal or "hand hole." The outdoor bandwidth transforming node **120** can operate in a temperature range between minus 40 degrees Celsius to plus 60 degrees Celsius. The bandwidth transforming node **120** can operate in this temperature range by using passive cooling devices that do not consume power.

Unlike conventional routers disposed between the subscriber optical interface **140** and the data service hub **110**, the outdoor bandwidth transforming node **120** does not require active cooling and heating devices that control the temperature surrounding the bandwidth transforming node **120**. The present invention attempts to place more of the decision-making electronics at the data service hub **110** instead of at the bandwidth transforming node **120**. Typically, the decision-making electronics are larger in size and produce more heat than the electronics placed in the bandwidth transforming node **120** of the present invention. Because the bandwidth transforming node **120** does not require active temperature controlling devices, the bandwidth transforming node **120** lends itself to a compact electronic packaging volume that is typically smaller than the environmental enclosures of conventional routers. Further details of the components that make up the bandwidth transforming node **120** will be discussed in further detail below with respect to Figures 4, 5, 13, 15, 16, and 17.

In one exemplary embodiment, the optical tap **130** can comprise an 8-way optical splitter. This means that the optical tap **130** comprising an 8-way optical splitter can divide downstream optical signals eight ways to serve eight different subscriber optical interfaces **140**. In the upstream direction, the optical tap **130** can combine the optical signals received from the eight subscriber optical interfaces **140**.

In another exemplary embodiment, the optical tap **130** can comprise a 4-way splitter to service four subscriber optical interfaces **140**. Yet in another exemplary embodiment, the optical tap **130** can further comprise a 4-way splitter that is also a pass-through tap. With a pass-through tap, a portion of the optical signal received at the optical tap **130** can be extracted to serve the 4-way splitter contained therein,

while the remaining optical energy is propagated further downstream to another optical tap **130** or another subscriber optical interface **140**. The present invention is not limited to 4-way and 8-way optical splitters. Other optical taps having fewer or more than 4-way or 8-way splitters are not beyond the scope of the present invention.

5 Referring now to Figure 2, this Figure is a functional block diagram illustrating an exemplary optical network architecture **100** that further includes subscriber groupings **200** that correspond with a respective outdoor bandwidth transforming node **120**. Figure 2 illustrates the diversity of the exemplary optical network architecture **100** where a number of optical waveguides **150, 170, 180**
10 connected between the outdoor bandwidth transforming node **120** and the optical taps **130** is minimized. Figure 2 also illustrates the diversity of subscriber groupings **200** that can be achieved with the optical tap **130**.

Each optical tap **130** can comprise an optical splitter. The optical tap **130** allows multiple subscriber optical interfaces **140** to be coupled to optical waveguides
15 **150, 170, 180** that are connected to the outdoor bandwidth transforming node **120**. In one exemplary embodiment, six optical waveguides are designed to be connected to the outdoor bandwidth transforming node **120**. Through the use of the optical taps **130**, sixteen subscribers can be assigned to each of the six optical waveguides that are connected to the outdoor bandwidth transforming node **120**.

20 In another exemplary embodiment, twelve optical waveguides can be connected to the outdoor bandwidth transforming node **120** while eight subscriber optical interfaces **140** are assigned to each of the twelve optical waveguides. Those skilled in the art will appreciate that the number of subscriber optical interfaces **140** assigned to particular waveguides **185, 190, 195** that are connected between the
25 outdoor bandwidth transforming node **120** and a subscriber optical interface **140** (by way of the optical tap **130**) can be varied or changed without departing from the scope and spirit of the present invention. Further, those skilled in the art recognize that the actual number of subscriber optical interfaces **140** assigned to the particular waveguide is dependent upon the amount of power available on a particular optical
30 waveguide.

As depicted in subscriber grouping **200**, many configurations for supplying communication services to subscribers are possible. For example, while optical tap **130_A** can connect subscriber optical interfaces **140_{A1}** through subscriber optical interface **140_{AN}** to the outdoor bandwidth transforming node **120**, optical tap **130_A** can also connect other optical taps **130** such as optical tap **130_{AN}** to the bandwidth transforming node **120**. The combinations of optical taps **130** with other optical taps **130** in addition to combinations of optical taps **130** with subscriber optical interfaces **140** are limitless. With the optical taps **130**, concentrations of distribution optical waveguides **150**, **170**, **180** at the bandwidth transforming node **120** can be reduced. Additionally, the total amount of fiber needed to service a subscriber grouping **200** can also be reduced.

With the active bandwidth transforming node **120** of the present invention, the distance between the bandwidth transforming node **120** and the data service hub **110** can comprise a range between 0 and 80 kilometers. However, the present invention is not limited to this range. Those skilled in the art will appreciate that this range can be expanded by selecting various off-the-shelf components that make up several of the devices of the present system.

Those skilled in the art will appreciate that other configurations of the optical waveguides disposed between the data service hub **110** and the outdoor bandwidth transforming node **120** are not beyond the scope of the present invention. Because of the bi-directional capability of optical waveguides, variations in the number and directional flow of the optical waveguides disposed between the data service hub **110** and the outdoor bandwidth transforming node **120** can be made without departing from the scope and spirit of the present invention.

Referring now to Figure 3, this functional block diagram illustrates an exemplary data service hub **110** of the present invention. The exemplary data service hub **110** illustrated in Figure 3 is designed for a two trunk optical waveguide system. That is, this data service hub **110** of Figure 3 is designed to send and receive optical signals to and from the outdoor bandwidth transforming node **120** along the first optical waveguide **150** and a second optical waveguide **160**, and possibly a third

optical waveguide **165**. With this exemplary embodiment, the second optical waveguide **160** supports bi-directional data flow.

The data service hub **110** can comprise one or more modulators **310, 315** that are designed to support television broadcast services. The one or more modulators
5 **310, 315** can be analog or digital type modulators. In one exemplary embodiment, there can be at least 78 modulators present in the data service hub **110**. Those skilled in the art will appreciate that the number of modulators **310, 315** can be varied without departing from the scope and spirit of the present invention.

The signals from the modulators **310, 315** are combined in a combiner **320**
10 where they are supplied to an optical transmitter **322**. The radio frequency signals generated by the modulators **310, 315** are converted into optical form in the optical transmitter **322**.

The optical transmitter **322** can comprise standard off-the-shelf analog externally modulated distributed feed back (DFB) laser transmitters, including those
15 manufactured by Synchronous and Arris. The laser optical transmitter **322** can also comprise one of Fabry-Perot (F-P) Laser Transmitters, and Vertical Cavity Surface Emitting Lasers (VCSELs). However, other types of optical transmitters are possible and are not beyond the scope of the present invention. With the aforementioned optical transmitters **322**, the data service hub **110** lends itself to efficient upgrading by
20 using off-the-shelf hardware to generate optical signals.

The one or more downstream optical signals generated by a laser optical transmitter **322** (referred to as the downstream unidirectional optical signals) are propagated to an amplifier **330**, such as an Erbium Doped Fiber Amplifier (EDFA), where the downstream unidirectional optical signals are amplified. The amplified
25 downstream unidirectional optical signals are then propagated out of the data service hub **110** via a unidirectional signal output port **335**, which is connected to one or more first optical waveguides **150**. The unidirectional signal output port **335** is connected to one or more first optical waveguides **150** that support unidirectional optical signals originating from the data service hub **110** to a respective bandwidth transforming
30 node **120**.

The data service hub **110** illustrated in Figure 3 can further comprise an Internet router **340**. The data service hub **110** can also comprise a telephone switch **345** that supports telephony service to the subscribers of the optical network system **100**. However, other telephony services, such as Internet Protocol telephony, can be supported by the data service hub **110**. If only Internet Protocol telephony is supported by the data service hub **110**, then it is apparent to those skilled in the art that the telephone switch **345** could be eliminated in favor of lower cost VoIP equipment. For example, in another exemplary embodiment (not shown), the telephone switch **345** could be substituted with other telephone interface devices such as a soft switch and gateway. But if the telephone switch **345** is needed, it may be located remotely from the data service hub **110** and can be connected through any of several conventional means of interconnection.

The data service hub **110** can further comprise a logic interface **350** that is connected to a bandwidth transforming node routing device **355**. The logic interface **350** can comprise a Voice over Internet Protocol (VoIP) gateway when required to support such a service. The bandwidth transforming node routing device **355** can comprise a conventional router that supports an interface protocol for communicating with one or more bandwidth transforming nodes **120**. This interface protocol can comprise one of gigabit or faster Ethernet and SONET protocols. However, the present invention is not limited to these protocols. Other protocols can be used without departing from the scope and spirit of the present invention.

The logic interface **350** and bandwidth transforming node routing device **355** can read packet headers originating from the bandwidth transforming node **120** and the internet router **340**. The logic interface **350** can also translate interfaces with the telephone switch **345**. After reading the packet headers, the logic interface **350** and bandwidth transforming node routing device **355** can determine where to send the packets of information.

The bandwidth transforming node routing device **355** can supply downstream data signals to respective laser optical transmitters **322** as described above. The data signals converted by the laser optical transmitters **322** can then be propagated downstream to a bi-directional splitter **360**. The downstream optical signals sent from

the laser optical transmitter **322** into the bi-directional splitter **360** can then be propagated towards a bi-directional data input/output port **365** that is connected to a second optical waveguide **160** that supports bi-directional optical data signals between the data service hub **110** and a respective bandwidth transforming node **120**.

5 Upstream optical signals received from a respective bandwidth transforming node **120** can be fed into the bi-directional data input/output port **365** where the optical signals are then forwarded to the bi-directional splitter **360**. From the bi-directional splitter **360**, respective optical receivers **370** can convert the upstream optical signals into the electrical domain. The upstream electrical signals generated
10 by respective optical receivers **370** are then fed into the bandwidth transforming node routing device **355**. Each optical receiver **370** can comprise one or more photoreceptors or photodiodes that convert optical signals into electrical signals.

When distances between the data service hub **110** and respective bandwidth transforming nodes **120** are modest, the laser optical transmitters **322** can propagate
15 optical signals at 1310 nanometers. But where distances between the data service hub **110** and the bandwidth transforming node are more extreme, the optical transmitters **322** can propagate the optical signals at wavelengths of 1550 nanometers with or without appropriate amplification devices.

Those skilled in the art will appreciate that the selection of optical transmitters
20 **322** for each circuit may be optimized for the optical path lengths needed between the data service hub **110** and the outdoor bandwidth transforming node **120**. Further, those skilled in the art will appreciate that the wavelengths discussed are practical but are only illustrative in nature. In some scenarios, it may be possible to use communication windows at 1310 nanometers and 1550 nanometers in different ways
25 without departing from the scope and spirit of the present invention. Further, the present invention is not limited to 1310 nanometer and 1550 nanometer wavelength regions. Those skilled in the art will appreciate that smaller or larger wavelengths for the optical signals are not beyond the scope and spirit of the present invention.

Referring now to Figure 4, this Figure illustrates a functional block diagram of
30 an exemplary outdoor bandwidth transforming node **120** of the present invention. In this exemplary embodiment, the bandwidth transforming node **120** can comprise a

unidirectional optical signal input port **405** that can receive optical signals propagated from the data service hub **110** that are propagated along a first optical waveguide **150**. The optical signals received at the unidirectional optical signal input port **405** can comprise broadcast video data. The optical signals received at the input port **405** are propagated to an amplifier **410**, such as an Erbium Doped Fiber Amplifier (EDFA), in which the optical signals are amplified. The amplified optical signals are then propagated to the unidirectional optical signal output port **415** and are then further propagated downstream.

The bandwidth transforming node **120** can further comprise a bi-directional optical signal input/output port **420** that connects the bandwidth transforming node **120** to a second optical waveguide **160** that supports bi-directional data flow between the data service hub **110** and the bandwidth transforming node **120**. Downstream optical signals flow through the bi-directional optical signal input/output port **420** to a fiber transceiver **425**, which can convert downstream optical signals into the electrical domain. The fiber transceiver **425** can further convert upstream electrical signals into the optical domain. The fiber transceiver **425** can comprise an optical/electrical converter and an electrical/optical converter.

Downstream and upstream electrical signals are communicated between the fiber transceiver **425** and an optical tap routing device **430**. The optical tap routing device **430** can manage the interface with the data service hub optical signals and can route or divide or apportion the data service hub signals according to which optical tap **130** is to receive the downstream signal or according to which optical tap **130** originated the upstream signal. More specifically, for downstream signals, the optical tap routing device **430** can manage the interface with the data service hub optical signals and can route these signals to the corresponding individual optical tap multiplexers **435** that communicate optical signals with particular optical taps **130** and ultimately one or more subscriber optical interfaces **140**. It is noted that tap multiplexers **435** operate in the electrical domain to modulate LED transmitters in order to generate optical signals that are assigned to groups of subscribers coupled to one or more optical taps **130**.

Similarly, the optical tap routing device **430** is notified of available upstream data packets as they arrive by each tap multiplexer **435**. The optical tap routing device **430** is connected to each tap multiplexer **435** to receive these upstream data packets. The optical tap routing device **430** relays the packets to the data service hub **110** via the fiber transceiver **425**. The optical tap routing device **430** can build a lookup table from these upstream data packets coming to it from all tap multiplexers **435** (or ports), by reading the source IP address of each packet, and associating it with the tap multiplexer **435** through which it came. This lookup table can then be used to route packets in the downstream path. As each packet comes in from the fiber transceiver **425**, the optical tap routing device **430** looks at the destination IP address (which is the same as the source IP address for the upstream packets). From the lookup table the optical tap routing device **430** can determine which port is connected to that IP address, so it sends the packet to that port. This can be described as a normal layer three router function as is understood by those skilled in the art.

The optical tap routing device **430** can assign multiple subscribers to a single port. More specifically, the optical tap routing device **430** can service groups of subscribers with corresponding respective, single ports. The optical taps **130** coupled to respective tap multiplexers **435** can supply downstream optical signals to pre-assigned groups of subscribers who receive the downstream optical signals with the subscriber optical interfaces **140**.

In other words, the optical tap routing device **430** can determine which tap multiplexers **435** are to receive a downstream electrical signal, or identify which of a plurality of optical taps **130** propagated an upstream optical signal (that is converted to an electrical signal). The optical tap routing device **430** can format data and implement the protocol required to send and receive data from each individual subscriber connected to a respective optical tap **130**. The optical tap routing device **430** can comprise a computer or a hardwired apparatus that executes a program defining a protocol for communications with groups of subscribers assigned to individual ports. One exemplary embodiment of the program defining the protocol is discussed in copending and commonly assigned provisional patent application entitled, "Protocol to Provide Voice and Data Services via Fiber Optic Cable," filed

on October 27, 2000 and assigned U.S. Application Serial No. 60/243,978, the entire contents of which are incorporated by reference. Another exemplary embodiment of the program defining the protocol is discussed in copending and commonly assigned provisional patent application entitled, "Protocol to Provide Voice and Data Services via Fiber Optic Cable-Part 2," filed on May 8, 2001 and assigned U.S. Application
5 Serial No. 60/289,112, the entire contents of which are incorporated by reference.

The single ports of the optical tap routing device 430 are connected to respective tap multiplexers 435. With the optical tap routing device 430, the bandwidth transforming node 120 can adjust a subscriber's bandwidth on a
10 subscription basis or on an as-needed or demand basis. The bandwidth transforming node 120 via the optical tap routing device 430 can offer data bandwidth to subscribers in pre-assigned increments. For example, the bandwidth transforming node 120 via the optical tap routing device 430 can offer a particular subscriber or groups of subscribers bandwidth in units of 1, 2, 5, 10, 20, 50, 100, 200, and 450
15 Megabits per second (Mb/s). Those skilled in the art will appreciate that other subscriber bandwidth units are not beyond the scope of the present invention.

Electrical signals are communicated between the optical tap routing device 430 and respective tap multiplexers 435. The tap multiplexers 435, along with LED optical transmitters 325 and optical receivers 370, propagate optical signals to and
20 from various groupings of subscribers. Each tap multiplexer 435 is connected to a respective light emitting diode (LED) optical transmitter 325. The LED optical transmitters 325 produce the downstream optical signals that are propagated towards the subscriber optical interfaces 140. As noted above, the LED optical transmitters 325 can comprise one or more of the Volgatech SLD series diodes or the SLD-56-MP
25 from Superlum, Ltd.

Each tap multiplexer 435 is also coupled to an optical receiver 370. Each optical receiver 370, as noted above, can comprise photoreceptors or photodiodes. Since the optical transmitters 325 can comprise low cost, off-the-shelf LEDs rather than lasers, and the and optical receivers 370 can comprise off-the-shelf
30 photoreceptors or photodiodes, the bandwidth transforming node 120 lends itself to efficient upgrading and maintenance to provide significantly increased data rates.

Each LED optical transmitter **325** and each optical receiver **370** can be connected to a respective bi-directional splitter **360**. Each bi-directional splitter **360** in turn can be connected to a wavelength division multiplexer/de-multiplexer **440**.

The signals propagating from each LED optical transmitter **325** or propagating
5 to each optical receiver **370** are combined in the bi-directional splitter **360**. The optical signals sent from the optical transmitter **325** into the bi-directional splitter **360** can then be propagated to the wavelength division multiplexer **440** and then towards a bi-directional input/output port **365** that is connected to another optical waveguide **170** that supports bi-directional optical data signals between the bandwidth
10 transforming node **120** and a respective optical tap **130**.

Once the downstream signals propagate from the bi-directional splitter **360** to the wavelength division multiplexer **440**, the wavelength division multiplexer **440** can select and combine or multiplex the wavelengths of light that propagate from each LED optical transmitter **325**. For example, an optical signal passed through a
15 wavelength division multiplexer **440** from a first optical transmitter **325** may be tuned at optical wavelength λ_a , while the signal passed through a wavelength division multiplexer **440** from a second transmitter **325** may be tuned at optical wavelength λ_b . The signal passed through a wavelength division multiplexer **440** from a third transmitter **325** may be tuned at optical wavelength λ_c , and the signal passed through
20 wavelength division multiplexer **440** from an n^{th} transmitter **325** may be tuned at optical wavelength λ_n . The corresponding receivers **370** operate at the same respective wavelengths.

By propagating information at different wavelengths, one optical waveguide can service a number of individual optical taps **130** that are connected to a like
25 number of optical tap multiplexers **435**. Moreover, as recognized by those skilled in the art, optical power is proportional to the width of each wavelength band. Thus, when more optical power is needed (for example, to service an optical tap **130** located a long distance away from the bandwidth transforming node **120**) larger wavelength bands can be used.

30 Unlike the conventional art, the bandwidth transforming node **120** does not employ a conventional router. The components of the bandwidth transforming node

120 can be disposed within a compact electronic packaging volume. For example, the bandwidth transforming node 120 can be designed to hang on a strand or fit in a pedestal similar to conventional cable TV equipment that is placed within the "last mile" or subscriber proximate portions of a network. It is noted that the term "last mile" is a generic term often used to describe the last portion of an optical network that connects to subscribers.

Also because the optical tap routing device 430 is not a conventional router, it does not require active temperature controlling devices to maintain the operating environment at a specific temperature. In other words, the bandwidth transforming node 120 can operate in a temperature range between minus 40 degrees Celsius to 60 degrees Celsius in one exemplary embodiment.

While the bandwidth transforming node 120 does not comprise active temperature controlling devices that consume power to maintain temperature of the bandwidth transforming node 120 at a single temperature, the bandwidth transforming node 120 can comprise one or more passive temperature controlling devices 450 that do not consume power. The passive temperature controlling devices 450 can comprise one or more heat sinks or heat pipes that remove heat from the bandwidth transforming node 120. Those skilled in the art will appreciate that the present invention is not limited to these exemplary passive temperature controlling devices listed. Further, those skilled in the art will also appreciate the present invention is not limited to the exemplary operating temperature range disclosed. With appropriate passive temperature controlling devices 450, the operating temperature range of the bandwidth transforming node 120 can be reduced or expanded.

In addition to the bandwidth transforming node's 120 ability to withstand harsh outdoor environmental conditions, the bandwidth transforming node 120 can also provide high speed symmetrical data transmissions. In other words, the bandwidth transforming node 120 can propagate the same bit rates downstream and upstream to and from a network subscriber. This is yet another advantage over conventional networks, which typically cannot support symmetrical data transmissions as discussed in the background section above. Further, the bandwidth transforming node 120 can also serve a large number of subscribers while reducing

the number of connections at both the data service hub 110 and the bandwidth transforming node 120 itself.

The bandwidth transforming node 120 also lends itself to efficient upgrading that can be performed entirely on the network side or data service hub 110 side. That is, upgrades to the hardware forming the bandwidth transforming node 120 can take place in locations between and within the data service hub 110 and the bandwidth transforming node 120. This means that the subscriber side of the network (from distribution optical waveguides 185, 190, 195 to the subscriber optical interfaces 140) can be left entirely intact during an upgrade to the bandwidth transforming node 120 or data service hub 110 or both.

The following is provided as an example of an upgrade that can be employed utilizing the principles of the present invention. In one exemplary embodiment of the invention, the subscriber side of the bandwidth transforming node 120 can service six groups of sixteen subscribers each for a total of up to 96 subscribers. Each group of sixteen subscribers can share a data path of about 450 Mb/s speed. Six of these paths represents a total speed of $6 \times 450 \text{ Mb/s} = 2.7 \text{ Gb/s}$. In the most basic form, the data communications path between the bandwidth transforming node 120 and the data service hub 110 can operate at 1 Gb/s. Thus, while the data path to subscribers can support up to 2.7 Gb/s, the data path to the network can only support one Gb/s. This means that not all of the subscriber bandwidth is useable. This is not normally a problem due to the statistical nature of bandwidth usage.

An upgrade could entail increasing the 1 Gb/s data path speed between the bandwidth transforming node 120 and the data service hub 110. This may be done by adding more 1 Gb/s data paths. Adding one more path would increase the data rate to 2 Gb/s, approaching the total subscriber-side data rate. A third data path would allow the network-side data rate to exceed the subscriber-side data rate. In other exemplary embodiments, the data rate on one link could increase from 1 Gb/s to 2 Gb/s and then to 10 Gb/s. Thus, when this happens, a link can be upgraded without adding more optical links.

An increase in data paths (bandwidth) may be achieved by any of the methods known to those skilled in the art. It may be accomplished by using a plurality of fiber

transceivers **425** operating over a plurality of optical waveguides, or by using a plurality of fiber transceivers **425** operating over one optical waveguide at a plurality of wavelengths, or by using higher speed fiber transceivers **425** as shown above. Thus, by upgrading the bandwidth transforming node **120** and the data service hub **110** to operate with more than a single 1 Gb/s link, a system upgrade is effected without having to make changes at the subscribers' premises.

Referring now to Figure 5, this Figure is a functional block diagram illustrating another exemplary embodiment of an outdoor bandwidth transforming node **120** according to the present invention. Only the differences between Figures 4 and 5 will be described with respect to Figure 5. Accordingly, the bandwidth transforming node **120** can comprise a bi-directional optical signal input/output port **420** that connects the bandwidth transforming node **120** to an optical waveguide **160** that supports bi-directional data flow between the data service hub **110** and the bandwidth transforming node **120**. Downstream optical signals can flow through the bi-directional optical signal input/output port **420** to a fiber transceiver **425**.

Downstream and upstream electrical signals can be communicated between the fiber transceiver **425** and an optical tap routing device **430**. The optical tap routing device **430** can service groups of subscribers with corresponding respective, single ports. The optical taps **130** coupled to respective tap multiplexers **435** can supply downstream optical signals to pre-assigned groups of subscribers who receive the downstream optical signals with the subscriber optical interfaces **140**.

The single ports of the optical tap routing device **430** are connected to respective tap multiplexers **435**. Electrical signals are communicated between the optical tap routing device **430** and respective tap multiplexers **435**. Each tap multiplexer **435** is connected to a respective light emitting diode (LED) optical transmitter **325** and an optical receiver **370**.

Each LED optical transmitter **325** can be connected to a downstream wavelength division multiplexer **500**. Additionally, each optical receiver **370** can be connected to an upstream wavelength division de-multiplexer **510**. The downstream signals propagating from each LED optical transmitter **325** can propagate from the transmitter **325** through the downstream wavelength division multiplexer **500** and out

the data signal output port **520** to the optical taps **130**. The upstream signals propagating from the optical taps **130** to the data service hub **110** propagate through the data signal input port **530** to the upstream wavelength division de-multiplexer **510** to the optical receiver **370**. One advantage the embodiment illustrated in Figure 5 has
5 over the embodiment illustrated in Figure 4 is that the embodiment illustrated in Figure 5 does not use bi-directional splitters **360**. Thus, the losses that can occur as a result of using bi-directional splitters **360** can be reduced or avoided.

Upstream optical signals can propagate from the optical taps **130** to the bandwidth transforming node **120** through a data signal input port **530**. The upstream
10 signals can then propagate from the data signal input port **530** to the upstream wavelength division de-multiplexer **510**, where the optical signals are de-multiplexed and routed to the corresponding optical receiver **370**.

The upstream wavelength division de-multiplexer **510** can select a different individual wavelength or wavelengths of light that propagate from a respective optical
15 tap **130**. For example, the signal propagating from a first optical tap **130** may be tuned at optical wavelength λ_a , the signal propagating from a second optical tap **130** may be tuned at optical wavelength λ_b , the signal propagating from a third optical tap **130** may be tuned at optical wavelength λ_c , and the signal propagating from an n^{th} optical tap **130** may be tuned at optical wavelength λ_n . The corresponding receivers
20 operate at the same respective wavelengths.

By propagating information at different wavelengths, one optical waveguide can service a number of individual optical taps **130** that are connected to a like number of optical tap multiplexers **435**. Propagating upstream optical signals at
25 different sets of multiple wavelengths enables each subscriber optical interface coupled to a common optical waveguide to transmit simultaneously. As discussed above, this is one advantage over the conventional art, which typically sequences upstream transmissions between subscriber optical interfaces **140** that are part of a particular subscriber grouping. With the present invention, carrier sense transmissions or staggering of upstream transmissions between optical taps **130** are
30 not necessary.

However, in one exemplary embodiment, carrier sense transmissions or staggering of upstream transmissions between subscriber optical interfaces **140** coupled to the same optical tap **130** may be necessary since optical interfaces **140** coupled to the same optical tap **130** typically operate at the same wavelength or wavelength region. In a further exemplary embodiment, the need for carrier sense transmissions or staggering of upstream transmissions between subscriber optical interfaces **140** that are coupled to the same optical tap **130** can be substantially reduced or eliminated if each subscriber optical interface is assigned a different wavelength or wavelength region relative to the other subscriber optical interfaces **140** that are serviced by the same optical tap **130**.

Figure 6 is a functional block diagram illustrating an optical tap **130** connected to subscriber optical interface **140** by a single optical waveguide **190** according to one exemplary embodiment of the present invention. The optical tap **130** can comprise a unidirectional signal output port **630** and a bi-directional data signal input/output port **650** that are connected to another distribution optical waveguide **170** which can be connected to additional optical taps **130**. Additionally, the optical tap **130** can comprise an optical splitter **510** that can be a 4-way or 8-way optical splitter. Other optical taps **130** having fewer or more than 4-way or 8-way splits are not beyond the scope of the present invention. The optical tap **130** can divide downstream optical signals to serve respective subscriber optical interfaces **140**. In the exemplary embodiment in which the optical tap **130** comprises a 4-way optical tap, such an optical tap can be of the pass-through type, meaning that a portion of the downstream optical signals is extracted or divided to serve a 4-way splitter contained therein, while the rest of the optical energy is passed further downstream on distribution optical waveguides **150, 170**.

The optical tap **130** is an efficient coupler that can communicate optical signals between the bandwidth transforming node **120** and a respective subscriber optical interface **140**. Optical taps **130** can be cascaded, or they can be connected in a star architecture from the bandwidth transforming node **120**.

The optical tap **130** can also connect to a limited or small number of optical waveguides so that high concentrations of optical waveguides are not present at any

particular bandwidth transforming node 120. In other words, in one exemplary embodiment, the optical tap can connect to a limited number of optical waveguides 185, 190, 195 at a point remote from the bandwidth transforming node 120 so that high concentrations of optical waveguides 185, 190, 195 at a bandwidth transforming node 120 can be avoided. However, those skilled in the art will appreciate that the optical tap 130 can be incorporated within the bandwidth transforming node 120.

In one exemplary embodiment, optical signals can propagate from the bandwidth transforming node 120 to the optical tap 130 through the unidirectional signal input port 605 via a broadcast waveguide 150. In another exemplary embodiment, signals can propagate from one optical tap 130 to another optical tap 130 through the unidirectional signal input port 605 via a broadcast waveguide 150. The broadcast signals propagating on the broadcast waveguide 150 can comprise analog and digital modulated radio frequency carriers.

Similarly, in one exemplary embodiment, optical signals can propagate from the bandwidth transforming node 120 to the optical tap 130 through the bi-directional data signal input/output port 610 via a targeted services waveguide 170. In another exemplary embodiment, signals can propagate from one optical tap 130 to another optical tap 130 through the bi-directional signal input/output port 610 via a targeted services waveguide 170. The targeted services waveguide 170 can carry targeted services as baseband digital signals.

The broadcast signals can propagate from the bandwidth transforming node 120 or another optical tap 130 through the input port 605 to an optical coupler 620. The optical coupler 620 can extract signal power from the broadcast waveguide 150 and route the extracted signal to an optical diplexer 625. Signals not extracted from the optical coupler 620 can also propagate to another optical tap 130 through the unidirectional signal output port 630.

The targeted services signals can propagate from the bandwidth transforming node 120 or another optical tap 130 to a spectral slicer 635 through the bi-directional data signal input/output port 610. The spectral slicer 635 can extract wavelengths of light comprising approximately 1310 nanometer wavelengths or wavelength regions near 1310 nanometers. However, wavelengths of light comprising approximately

1550 nanometers could also be used. Those skilled in the art recognize these spectra as particularly well suited for communication applications and that other ranges in the spectra are not beyond the scope of the present invention.

Those optical signals not extracted from the spectral slicer **635** can propagate
5 through the bi-directional data signal input/output port **650** downstream to additional optical taps **130**. The extracted optical signals from the spectral slicer **635** can also propagate to the optical diplexer **625** where they can be combined with the broadcast signal from the optical coupler **620**. The signal passes to the optical diplexer **625** through a blocking optical filter **600**, which is used to prevent upstream optical energy
10 at unused wavelengths from contaminating downstream signals, as will be explained more fully below and in Figure 12B. Although Figure 6 illustrates an optical filter **600** disposed between a spectral slicer **635** and an optical diplexer **625**, in another exemplary embodiment (not shown), as is understood by one skilled in the art, the optical filter **600** could be physically located within the spectral slicer **635**.

15 The combined signals can propagate from the optical diplexer **625** to an optical splitter **510**. The optical splitter **510** divides the combined signal from the diplexer **625** among the one or more subscribers that are connected to the optical tap **130**. The combined signal from the diplexer **625** propagates via an optical waveguide **190** to a subscriber optical interface **140**, which is typically located in close proximity
20 to a subscriber's home.

The subscriber optical interface **140** functions to convert downstream optical signals received from the optical tap **130** into the electrical domain so that the converted electrical signals can be processed by appropriate communication devices. The subscriber optical interface **140** further functions to convert upstream electrical
25 signals into upstream optical signals that can be propagated along a distribution optical waveguide **190** to the optical tap **130**. The subscriber optical interface **140** can comprise an optical diplexer **655** that divides the downstream optical signals received from the distribution optical waveguide **190** between a bi-directional optical signal splitter **670** and an analog optical receiver **660**.

30 In other words, the combined signal that comprises broadcast and targeted services optical signals can propagate downstream from the optical tap **130** to the

subscriber optical interface **140** through an optical diplexer **655**. The optical diplexer **655** separates the combined signals into two signals, comprising one at about 1310 nanometers and one at about 1550 nanometers. The 1550 nanometer signal, which can comprise the broadcast signal that further comprises a plurality of radio frequency modulated signals in optical form, can propagate downstream to an analog optical receiver **660**, and then through a modulated radio frequency unidirectional signal output **665**. The modulated radio frequency unidirectional signal output **665** can feed to RF receivers such as television sets (not shown) or radios (not shown). The analog optical receiver **660** can process analog modulated RF transmission as well as digitally modulated RF transmissions for digital TV applications.

In contrast, a 1310 nanometer signal can propagate downstream from the optical diplexer **655** to a bi-directional optical signal splitter **670**. The signal splitter **670** routes the downstream targeted services signals to a digital optical receiver **675**.

As will be discussed further below, the optical diplexer **655** of the subscriber optical interface **140** can also receive upstream optical signals generated by a digital optical transmitter **685**. The digital optical transmitter **685** converts electrical binary/digital signals to optical form so that the optical signals can be transmitted back to the data service hub **110**. Conversely, the digital optical receiver **675** converts optical signals into electrical binary/digital signals so that the electrical signals can be handled by processor **680**. The optical transmitters **685** produce the upstream optical signals that are propagated towards the optical taps **130**. The optical transmitters **685** can comprise one or more of the Volgatech SLD series diodes or the SLD-56-MP from Superlum, Ltd., similar to the optical transmitters **325** of the bandwidth transforming node **120**. The digital optical receivers **675** can comprise photodiodes or photoreceptors, similar to optical receivers **370** of the bandwidth transforming node **120**.

The bi-directional optical signal splitter **670** can propagate combined optical signals in their respective directions. That is, downstream optical signals entering the bi-directional optical signal splitter **670** from the optical diplexer **655** can be propagated to the digital optical receiver **675**. Upstream optical signals entering the bi-directional splitter **670** from the digital optical transmitter **685** can be sent to the

optical diplexer **655** and then to the optical tap **130**. As mentioned above, the bi-directional optical signal splitter **670** is connected to a digital optical receiver **675** (comprising one or more photoreceptors or photodiodes) that can convert downstream data optical signals into the electrical domain. Meanwhile the bi-directional optical
5 signal splitter **670** is also connected to a digital optical transmitter **685** that converts upstream electrical signals into the optical domain.

The digital optical transmitter **685** emits optical signals comprising a broad spectrum of wavelengths. The wavelengths transmitted upstream from the digital optical transmitter **685** can comprise the same wavelengths transmitted downstream to
10 the digital optical receiver **675**. The spectrum transmitted upstream can be selected or extracted by the spectral slicer **635** working in combination with optical filter **600**. Further details of the operation of spectral slicer will be discussed below with respect to Figures 12A-12C.

The output of the digital optical transmitter **685** of an optical interface **140** of a
15 subscriber grouping (where optical interfaces **140** of a subscriber grouping are coupled to the same optical tap **130**) typically emits signals at wavelengths including those used in the downstream direction by the other optical interfaces **140** of the subscriber grouping. The optical filter **600** can block unwanted wavelengths emitted upstream from the digital optical transmitter **685**, and thereby prevents the unwanted
20 wavelengths (the optical power at wavelengths other than the wavelength to which the spectral slicer **635** is tuned) from being propagated through the spectral slicer **635** in the downstream direction. In this way, the filter **600**, which is tuned to the same wavelengths as the spectral slicer **635**, prevents the unwanted upstream wavelengths from interfering with other signals propagated to downstream users.

The functionality of the filter **600** compared to the spectral slicer **635** can be
25 characterized as follows: the filter **600** may be considered as a blocking type filter whereas the spectral slicer may be characterized as a pass thru filter. The blocking filter **600** stops or prevents unwanted wavelengths from passing through the filter **600** while the spectral slicer **635** passes unwanted wavelengths therethrough and reflects
30 the desired or wanted wavelengths to another waveguide.

The digital optical receiver **675** and digital optical transmitter **685** can be connected to a processor **680** that selects data intended for the instant subscriber optical interface **140** based upon an embedded address. The data handled by the processor **680** can comprise one or more of telephony and data services such as an Internet service. The processor **680** is connected to a telephone input/output **690** that can comprise an analog interface. The processor **680** is also connected to a data interface **695** that can provide a link to computer devices, set top boxes, ISDN phones, and other like devices. Alternatively, the data interface **695** can comprise an interface to a Voice over Internet Protocol (VoIP) telephone or Ethernet telephone.

5 The data interface **695** can comprise one of Ethernet's (10BaseT, 100BaseT, Gigabit) interface, HPNA interface, a universal serial bus (USB) an IEEE1394 interface, an ADSL interface, and other like interfaces.

The present invention can propagate the optical signals at various wavelengths. However, the wavelength regions discussed are practical and are only illustrative of exemplary embodiments. Those skilled in the art will appreciate that other wavelengths that are either higher or lower than or between the 1310 nanometer and 1550 nanometer wavelength regions are not beyond the scope of the present invention.

15

Referring now to Figure 7, this figure is a functional block diagram illustrating another optical tap **130** connected to a optical subscriber interface **140** by both an optical waveguide **190** and a wire conductor **750** according to another exemplary embodiment of the present invention. Only the differences between Figures 6 and 7 will be discussed with respect to Figure 7. As discussed above and as illustrated in Figure 6, in one exemplary embodiment of the present invention, an analog optical receiver **660** can be installed or housed in the subscriber optical interface **140** to process analog modulated RF transmission as well as digitally modulated RF transmissions for digital TV applications. Not only can the signals be analog modulated (such as conventional NTSC television transmissions) or digitally modulated (such as those transmitted using the ATSC digital format using VSB modulation), but they can also be in a modified format (such as the format used by the

20

25

30

cable television industry that uses QAM modulation), and the modulation can be mixed as the system operator sees fit.

However, in one exemplary embodiment of the present invention the analog optical receiver **660** can be located in the optical tap **130**. One advantage of this exemplary embodiment over the exemplary embodiment described in Figure 6 is that the analog optical receiver **660** in optical tap **130** can serve all subscribers connected to the optical tap **130**. An additional advantage of this exemplary embodiment over the exemplary embodiment discussed in Figure 6 (with the analog receiver **660** located in the subscriber optical interface **140**), is that the embodiment illustrated in Figure 7 can reduce or eliminate any losses of signal strength that can occur in some of the devices used in Figure 6. For example, as is known by those skilled in the art, the power strength of a signal could be reduced as that signal passes through optical splitters, optical couplers, and diplexers. Because the design in Figure 6 relies on these devices, it requires that the optical amplifier **410** in the bandwidth transforming node **120** to compensate for these power losses that could occur. As is known to those skilled in the art, the cost of an amplifier is related to the output level required. Thus, if the output level that is required can be reduced, significant cost savings can be achieved.

As noted above, the analog optical receiver **660** can serve all homes connected to the optical splitter **640**. The optical tap **130** is powered from circuitry **720** added in the subscriber optical interface **140**. Additionally, steering diodes (not shown) located in the optical tap **130** can combine the power from each subscriber to operate the common equipment in the analog optical receiver **660** through the power extraction circuit **700**.

In another exemplary embodiment, the optical tap **130** can be powered using a cable that brings power from the bandwidth transforming node **120** or another place in the distribution plant. This cable can be co-located with the broadcast waveguides **150** and targeted services waveguides **170** or it can be routed separately.

The signals not extracted from the spectral slicer **635** can propagate through the bi-directional data signal input/output port **650** downstream to additional optical taps **130**. The extracted signal from the spectral slicer **635** can also propagate to the

filter 600, where the filter 600 prevents unwanted wavelengths from passing therethrough. The signal can then propagate from the filter 600 to the subscriber optical interface 140 via an optical splitter 640. The optical splitter 640 can divide downstream optical signals among one or more subscriber optical interfaces 140.

5 The subscriber optical interface 140 can comprise a power insertion circuit 720, which powers the analog optical receiver 660 of the optical tap 130. The subscriber optical interface 140 can also comprise a modulated RF unidirectional signal output 665 for carrying broadcast signals to broadcast receivers, such as televisions or radios.

10 The targeted services signals can propagate downstream to the subscriber optical interface 140 where they are processed by a bi-directional optical signal splitter 670. The signal splitter 670 routes the downstream signals to a digital optical receiver 675.

 As will be discussed further below, the spectral slicer 635 can also receive
15 upstream optical signals generated by a digital optical transmitter 685. The digital optical transmitter 685 converts electrical binary/digital signals to optical form so that the optical signals can be transmitted back to the data service hub 110. Conversely, the digital optical receiver 675 converts optical signals into electrical binary/digital signals so that the electrical signals can be handled by processor 680.

20 Referring now to Figure 8, this figure is a functional block diagram illustrating another optical tap 130 connected to a bandwidth transforming node 120 by two optical waveguides 150, 170 according to another exemplary embodiment of the present invention. Only the differences between Figures 6 and 8 will be discussed with respect to Figure 8. Accordingly, one advantage the embodiment illustrated in
25 Figure 8 has over the embodiment illustrated in Figure 6 is the design in Figure 8 avoids the use of any diplexers. Thus, the losses that could possibly occur as a result of using diplexers can be reduced or substantially eliminated.

 In Figure 8, an optical coupler 620 can extract a portion of the downstream unidirectional signal and send the extracted signal to an optical splitter 820. The
30 remainder of the downstream signal can propagate to other optical taps 130 further downstream via a unidirectional signal output port 630. An optical splitter 820 can

split the optical signal from the optical coupler **620** and then can send it to a subscriber over a downstream optical waveguide **185**. The subscriber optical interface **140** (which is located at the subscriber) receives the downstream broadcast signal from the downstream optical splitter **820** and routes the signal to an analog optical receiver **660**. The signal from the analog optical receiver **660** can propagate to the subscriber via a modulated RF unidirectional signal output **665**.

Targeted services signals can propagate downstream to the optical tap **130** from the bandwidth transforming node **120** (or another optical tap **130**) via a targeted services waveguide **170**. The targeted services signals enter the optical tap **130** through a bi-directional data signal input/output port **610** and can propagate to a spectral slicer **635**. This spectral slicer **635** operates as described above, in that it extracts certain prescribed wavelengths that are assigned to a reduced set of subscribers. The optical splitter **830** receives the extracted wavelengths from the spectral slicer **635** via optical filter **600**, and splits the signals to serve the plurality of homes serviced from this optical tap **130**. The optical splitter **830** and the spectral slicer **635** can also receive upstream signals propagating from the subscriber optical interface **140** to the data service hub **110** via the bi-directional data signal input/output port **650**.

The bi-directional optical signal splitter **670** of the subscriber optical interface **140** can propagate combined optical signals in their respective directions. That is, downstream optical signals entering the bi-directional optical signal splitter **670** from the spectral slicer **635** can be propagated to the digital optical receiver **675**. Upstream optical signals entering the optical signal splitter **670** from the digital optical transmitter **685** can be sent to the optical tap **130**. These upstream optical signals propagate from the digital optical transmitter **685** to the optical tap **130** by first propagating through a bi-directional signal splitter **670**. The upstream optical signals originating from a plurality of subscribers can be further combined in the optical splitter **830** and spectral slicer **635** located in the optical tap **130**. The combined upstream signals can then propagate to other upstream optical taps **130** or to the data service hub **110** after passing through the bi-directional data signal input-output port **610** along the targeted services waveguide **170**.

Referring now to Figure 9, this figure is a functional block diagram illustrating another optical tap 130 connected to a bandwidth transforming node 120 by three optical waveguides 150, 170, 180 according to another exemplary embodiment of the present invention. In one exemplary embodiment, signals can propagate from the bandwidth transforming node 120 to the optical tap 130 through the unidirectional signal input port 605 via the broadcast waveguide 150. In another exemplary embodiment, signals can propagate from one optical tap 130 to another optical tap 130 through the unidirectional signal input port 605 via the broadcast waveguide 150. The broadcast signals propagating on the broadcast waveguide 150 are analog and digital modulated radio frequency carriers.

In another exemplary embodiment, signals can propagate from the bandwidth transforming node 120 to the optical tap 130 through the downstream data signal input port 900 via the downstream targeted services waveguide 170. In another exemplary embodiment, signals propagate from one optical tap 130 to another optical tap 130 through the downstream data signal input port 900 via the downstream targeted services waveguide 170.

In contrast, upstream signals can propagate from the subscriber optical interface 140 to the data service hub 110 through the optical splitter 640 in the optical tap 130 over an upstream targeted services waveguide 195. In this exemplary embodiment, a blocking filter 600 is not needed, because the optical signals propagating upstream from the digital optical transmitter 685 that are not extracted by the spectral slicer 930 typically do not propagate downstream. In this exemplary embodiment there are no intentional downstream signals on optical waveguide 180. Therefore, any downstream signals that could be generated and propagate along optical waveguide 180 in the downstream direction are of no consequence.

The downstream broadcast signals can propagate from the bandwidth transforming node 120 or another optical tap 130 through the input port 605 to an optical coupler 620. The optical coupler 620 extracts signal power from the broadcast waveguide 150 and routes the extracted signal to the optical diplexer 625. Signals not extracted by the optical coupler 620 can also propagate to another optical tap 130 through the unidirectional signal output port 635.

Downstream targeted services signals can propagate from the bandwidth transforming node 120 or another optical tap 130 to a downstream spectral slicer 910 through the downstream data signal input port 900. The downstream spectral slicer 910 extracts one or more wavelengths of light located approximately at 1310 nanometers. However, other wavelengths of light located approximately at 1550 nanometers could also be used. Those skilled in the art recognize these spectra as particularly well suited for communication applications and that other ranges of wavelengths are not beyond the scope of the present invention.

As mentioned above, the remaining optical signals not extracted from the spectral slicer 910 can be propagated downstream through the downstream data signal output port 940 to additional optical taps 130. The extracted signal from the spectral slicer 910 can also be propagated to the optical diplexer 625, where it can be combined with the downstream broadcast signal from the optical coupler 620. The combined broadcast/targeted services signal can propagate from the optical diplexer 625 to an optical splitter 640. The optical splitter 640 divides the combined signal from the diplexer 625 among the one or more subscribers who are connected to the optical tap 130. The combined signal from the diplexer 625 can propagate via a single waveguide 190 to a subscriber optical interface 140, which is located in close proximity to a subscriber.

The subscriber optical interface 140 can comprise an optical diplexer 655 that divides the downstream optical signals received from the distribution optical waveguide 190 between a digital optical receiver 675 and an analog optical receiver 660. In other words, the combined signal propagates downstream from the optical tap 130 to the subscriber optical interface 140 through an optical diplexer 655. The optical diplexer 655 separates the combined signal into two signals, one at about 1310 nanometers and one at about 1550 nanometers. The 1550 nanometer signal, which can comprise a plurality of radio frequency modulated signals in optical form (also referred to as a broadcast signal), propagates downstream to an analog optical receiver 660, and then through a modulated radio frequency unidirectional signal output 665. The output of the analog optical receiver 660 is a conventional electrical signal containing a plurality of analog and digital modulated broadcast signals. The analog

optical receiver **660** can process analog modulated RF transmissions as well as digitally modulated RF transmissions for digital TV applications.

In contrast, the 1310 nanometer signal can propagate downstream from the optical diplexer **655** to a digital optical receiver **675**. The digital optical receiver **675** converts optical signals into electrical binary/digital signals so that the electrical signals can be handled by a processor **680**. The digital optical receiver **675** can comprise one or more photoreceptors or photodiodes that convert optical signals into the electrical domain. The digital optical transmitter **685** can comprise one or more LEDs.

The optical tap **130** can also receive upstream data signals propagating upstream from the subscriber to the data service hub **110** through a digital optical transmitter **685**. More specifically, signals can propagate from a telephone input/output **690** and a data interface **695** to a processor **680**. The processor can send upstream signals through a digital optical transmitter **685** to the optical tap **130** through an optical splitter **640**. The optical splitter in turn sends the signal to an upstream spectral slicer **930**. From the spectral slicer **930** the signal can propagate further upstream via the upstream data signal output port **915** and along the upstream targeted services waveguide **180**. The digital optical transmitter **685** converts upstream electrical binary/digital signals to optical form so that the optical signals can be transmitted back to the data service hub **110**. Additionally, upstream signals can propagate from other optical taps **130** to the data service hub **110** through the upstream data signal input port **950**.

As noted above, the present invention can propagate the optical signals at various wavelengths. However, the wavelength regions discussed above are practical and are only illustrative of exemplary embodiments. Those skilled in the art will appreciate that other wavelengths that are either higher or lower than or between the 1310 nanometer and 1550 nanometer wavelength regions are not beyond the scope of the present invention.

Figure 10 is a functional block diagram illustrating another optical tap **130** connected to a bandwidth transforming node **129** by three optical waveguides **150**, **170**, **180** according to another exemplary embodiment of the present invention. Only

the differences between Figures 6 and 10 will be discussed with respect to Figure 10. In one exemplary embodiment, signals can propagate from the bandwidth transforming node 120 to the optical tap 130 through the unidirectional signal input port 605 via the broadcast waveguide 150. In another exemplary embodiment, signals
5 can propagate from one optical tap 130 to another optical tap 130 through the unidirectional signal input port 605 via the broadcast waveguide 150. The broadcast signals propagating on the broadcast waveguide 150 comprise analog and digital modulated radio frequency optical signals.

Similarly, downstream targeted services signals can propagate from the
10 bandwidth transforming node 120 to the optical tap 130 through the downstream data signal input port 900 via the downstream targeted services waveguide 170. In another exemplary embodiment, downstream targeted services signals can propagate from one optical tap 130 to another optical tap 130 through the downstream data signal input port 900 via the downstream targeted services waveguide 170.

15 Upstream targeted services signals can propagate from the subscriber optical interface 140 to the data service hub 110 through the upstream data signal output port 915 in the optical tap 130 over an upstream targeted services waveguide 180. In another exemplary embodiment, signals can propagate from another optical tap 130 to the data service hub 110 through the upstream data signal output port 915.

20 The downstream broadcast signals can propagate from the bandwidth transforming node 120 or another optical tap 130 through the input port 605 to an optical coupler 620. The optical coupler 620 extracts downstream signals from the broadcast waveguide 150 and routes the extracted signals to an optical splitter 640. Signals not extracted by the optical coupler 620 can also propagate to another optical
25 tap 130 through the unidirectional signal output port 630.

The targeted services signals propagate from the bandwidth transforming node 120 or another optical tap 130 to a downstream spectral slicer 910 through the downstream data signal input port 900. The downstream spectral slicer 910 extracts wavelengths of light. The wavelengths not extracted from the spectral slicer 910 can
30 propagate downstream through the downstream data signal output port 940 to additional optical taps 130. The extracted wavelengths or signals from the spectral

slicer **910** can propagate to a downstream optical splitter **640**, where it is divided by the optical splitter **640** among the one or more subscribers who are connected to the optical tap **130**. The signal from the optical splitter **640** can propagate via a single waveguide **190** to a subscriber optical interface **140**, which is located in close
5 proximity to a subscriber.

The downstream broadcast signal can propagate from an optical splitter **640** via the downstream broadcast waveguide **185** to an analog optical receiver **660** in the subscriber optical interface **140**. The signal can then propagate from the analog optical receiver **660** through a modulated radio frequency unidirectional signal output
10 **665**. The output of the analog receiver **660** is a conventional electrical signal containing a plurality of analog and digital modulated broadcast signals.

The targeted services signal can propagate downstream from a downstream optical splitter **640** over a downstream targeted services waveguide **190** to a digital optical receiver **675** located in the subscriber optical interface **140**. The digital optical
15 receiver **675** converts optical signals into electrical binary/digital signals so that the electrical signals can be handled by processor **680**. The digital optical receiver **675** can comprise one or more photoreceptors or photodiodes that convert optical signals into the electrical domain.

The optical tap **130** can also receive upstream data signals propagating
20 upstream from the subscriber to the data service hub **110** through a digital optical transmitter **685**. More specifically, signals propagate from a telephone input/output **690** and a data interface **695** to a processor **680**. The processor sends upstream signals through a digital optical transmitter **685** to the optical tap **130** via an upstream targeted services waveguide **195** through an optical splitter **640**. The optical splitter,
25 in turn, sends the signal to an upstream spectral slicer **930**. From the spectral slicer **930**, the signal propagates further upstream via the upstream data signal output port **915** and along the upstream targeted services waveguide **180**. The digital optical transmitter **685** converts upstream electrical binary/digital signals to optical form so that the optical signals can be transmitted back to the data service hub **110**.

30 The digital optical receiver **675** and digital optical transmitter **685** are connected to a processor **680** that selects data intended for the instant subscriber

optical interface **140** based upon an embedded address. The data handled by the processor **680** can comprise one or more of telephony and data services such as an Internet service.

Figure 11 is a functional block diagram illustrating another optical tap **130** connected to a bandwidth transforming node **120** by three optical waveguides **150**, **170**, **180** according to another exemplary embodiment of the present invention. Only the structural differences between Figures 6 and 11 will be discussed with respect to Figure 11. One advantage of the embodiment illustrated in Figure 11 over the embodiment illustrated in Figure 9 is lower cost through the use of a dual spectral slicer **1100** (as opposed to using a downstream spectral slicer **910** and an upstream spectral slicer **930**). An advantage of the embodiment illustrated in Figure 11 over the embodiment illustrated in Figure 10 is that the upstream targeted services waveguide **180** remains continuous; it does not need to be broken at every optical tap **130**.

In one exemplary embodiment of the present invention, broadcast signals can propagate from the bandwidth transforming node **120** to the optical tap **130** through the unidirectional signal input port **605** via the broadcast waveguide **150**. In another exemplary embodiment, broadcast signals can propagate from one optical tap **130** to another optical tap **130** through the unidirectional signal input port **605** via the broadcast waveguide **150**.

In one exemplary embodiment, downstream targeted services signals can propagate from the bandwidth transforming node **120** to the optical tap **130** through the downstream data signal input port **900** via the downstream targeted services waveguide **170**. In another exemplary embodiment, signals propagate from one optical tap **130** to another optical tap **130** through the downstream data signal input port **900** via the downstream targeted services waveguide **170**.

The broadcast signals can propagate from the bandwidth transforming node **120** or another optical tap **130** through the unidirectional signal input port **605** to an optical coupler **620**. The optical coupler **620** extracts signals from the broadcast waveguide **150** and routes the extracted signals to an optical splitter **640**. Broadcast signals not extracted from the optical coupler **620** can also propagate to another optical tap **130** through the unidirectional signal output port **630**. The downstream

broadcast signals propagate from an optical splitter 640 via the downstream broadcast waveguide 185 to an analog optical receiver 660 in the subscriber optical interface 140. The downstream broadcast signal then propagates from the analog optical receiver 660 through a modulated radio frequency unidirectional signal output 665 to
5 one or more television sets located at the subscriber end.

Upstream data signals can propagate from the subscriber optical interface 140 to the data service hub 110 through a filter 600 in the optical tap 130 over an upstream targeted services waveguide 195. The upstream signals can propagate to the data service hub 110 via an upstream targeted services waveguide 180 from the last optical
10 tap 130. Until reaching the last optical tap 130 in a cascade of taps, the upstream optical signals propagate downstream on downstream optical waveguide 170, using wavelengths that are permitted to pass through the dual spectral slicer 1100. The targeted services waveguides 170, 180 carry targeted services as baseband digital signals.

The downstream targeted services signals can propagate from the bandwidth transforming node 120 or another optical tap 130 to a dual spectral slicer 1100 through the downstream data signal input port 900. The dual spectral slicer 1100 extracts wavelengths of light at this optical tap 130, while other wavelengths can be extracted at other optical taps 130 in the optical network system 100. The
15 wavelengths not extracted can propagate downstream through the dual spectral slicer 1100 and through the downstream data signal output port 940 to additional optical taps 130. The extracted signal from the dual spectral slicer 1100 can propagate to an optical splitter 640 where it is divided by the optical splitter 640 among the one or more subscribers that are connected to the optical tap 130. The signal from the optical
20 splitter 640 propagates via a single waveguide 190 to a subscriber optical interface 140, which is located in close proximity to a subscriber's home or in another convenient location.

The targeted services signal propagates downstream from the optical splitter 640 over a downstream targeted services waveguide 190 to a digital optical receiver
30 675 located in the subscriber optical interface 140. The digital optical receiver 675 converts optical signals into electrical binary/digital signals so that the electrical

signals can be handled by processor **680**. The digital optical receiver **675** can comprise one or more photoreceptors or photodiodes that convert optical signals into the electrical domain.

The optical tap **130** can also receive upstream data signals propagating
5 upstream from the subscriber to the data service hub **110** through a digital optical transmitter **685**. More specifically, signals propagate from a telephone input/output **690** and a data interface **695** to a processor **680**. The processor sends upstream signals through a digital optical transmitter **685** to the optical tap **130** via an upstream targeted services waveguide **195** to an optical splitter **640**. The optical splitter **640** (a
10 bi-directional device) combines the outputs of other optical interfaces **140** attached to this optical tap **130**.

A filter **600** located between the optical splitter **640** and the dual spectral slicer **1100** blocks optical power at wavelengths not selected by the dual spectral slicer **1100** to prevent interference with other optical signals. The optical splitter **640** in turn
15 sends the signal to a dual spectral slicer **1100**. From the dual spectral slicer **1100**, the signal propagates in the downstream direction on the targeted services downstream waveguide **170** until it reaches the farthest optical tap **130** in a chain of optical taps **130**. At this point, all downstream signals are propagated back up to the bandwidth transforming node **120** on the upstream targeted services waveguide **180**.

Referring now to Figure 12A, this figure illustrates the operation of spectral
20 slicers **635** that are present within the optical taps **130** of the present invention. More specifically, this figure illustrates a plot **1200** of wavelength versus response and source spectrum of a digital optical transmitters **325**, **685**. The emission spectrum **1205** of the optical transmitters **325**, **685** is shown as a solid line. The width of the
25 response corresponds to the wavelength bandwidth of the transmitters **325**, **685**.

The response **1210** of a spectral slicer **635** and also optical filter **600** is shown with dashed lines. The response of spectral slicer **635** shown in Figure 12A is the response between the common port, **PC**, and a second Port, **P2**, as defined in Figure 12B. The response from the common port **PC** to a first port **P1** is the opposite; if the
30 slicer is tuned to wavelength λ_1 , then the response from the common port **PC** to the first port **P1** (or vice versa) will not allow signals at wavelength λ_1 to pass, but will

allow all other signals to pass. It is possible to produce spectral slicers **635** and filters **600** tuned at various wavelengths across the spectrum (where complementary slicers **635** and blocking filters **600** are tuned to the same wavelength or wavelength regions), and a number of wavelengths can be used, as shown. Wavelength λ_i represents any
5 one of several wavelengths - λ_1, λ_2 , up to the longest wavelength, λ_n . Connected to each of a plurality of bandwidth transforming nodes **120** are up to n optical taps **130**, each with a spectral slicer **635** and an optical filter **600** (when necessary) that are tuned to a unique wavelength slice or region. The responses **1210** shown also apply to wavelength division multiplexers/de-multiplexers **440, 500, 510**.

10 Figure 12B illustrates how an upstream data signal generated by a transmitter **685** is handled by an optical tap **130**. Figure 12B describes the basic functionality between the spectral slicer **635** of the optical tap **130** and the optical diplexer disposed within the subscriber optical interface **140**. Figure 12B does not illustrate the optical filter **600** disposed between the spectral slicer **635** and the diplexer **625** and the other
15 intermediate components, such as optical splitters **510** and optical diplexers **625** that may present as illustrated in Figure 6.

The optical transmitter **685** emits optical power at many wavelengths **1205**. For a spectral slicer tuned to wavelength λ_i , upstream signals with a wavelength λ_i will be reflected from the second port **P2** of the spectral slicer **635** to the common port
20 **PC**. The reflected signals will then propagate further upstream. In contrast, signals propagating at other wavelengths will pass through second port **P2** to the first port **P1**, and will therefore propagate further downstream (if not otherwise blocked by using a filter **600** not shown in Figure 12B). Thus, when other wavelengths having optical power could cause interference with other signals further downstream, these
25 unwanted wavelengths can be stopped or removed by using a blocking optical filter **600** (not shown in Figure 12B but shown in Figure 6).

Figure 12C illustrates how a downstream signal is handled by an optical tap **130** when that signal originates from the bandwidth transforming node **120**. Similar to Figure 12B, Figure 12C focuses on the relationship between the slicer **635** and the
30 diplexer **625** without describing any intermediate structures disposed between these

two components as illustrated in Figure 6. The LED optical transmitter **325** in the bandwidth transforming node **120** emits a narrow band of light, having been filtered by another filter (not shown). The signal at wavelength λ_i is reflected from the common port **PC** of spectral slicer **635** to port **P2**, to which an optical diplexer **625** is connected. Signals at other wavelengths pass through the spectral slicer **635** from the common port **PC** to port **PI**. These signals at other wavelengths are propagated from other transmitters **325** within the bandwidth transforming node **120**.

Figure 13 illustrates the operation of transmitters **325** and receivers **370** disposed within an outdoor bandwidth transforming node **120** and the operation of bandpass filters **600** that may be used with spectral slicers **635** forming the optical taps **130** of the present invention. More specifically, Figure 13 illustrates the transmitters **325** and receivers **370** in one bandwidth transforming node **120**, each supplying optical signals to a wavelength division multiplexer/de-multiplexer **440** having multiple passbands.

A first transmitter **325₁** and its receiver **370₁** are connected to a bandpass filter **1330**. The bandpass filter **1330** has multiple responses labeled F1, at wavelengths λ_1 , λ_4 , and λ_7 . Similarly, for a second transmitter **325₂** and receiver **370₂**, a bandpass filter **1360** has multiple responses labeled F2 at wavelengths λ_2 , λ_5 , and λ_8 . For a third transmitter **325₃** and receiver **370₃**, a third bandpass filter **1390** has multiple responses at λ_3 , λ_6 , and λ_9 . In this exemplary embodiment the responses do not overlap with the passbands for the other transmitters **325** and receivers **370**.

Spectral slicing is performed in each optical tap **130** using a filter corresponding to the wavelengths to be picked off of (or "sliced," from) that tap. For example, one transmitter **325₁** is intended to send signals to a digital optical receiver **675₁**, so the optical tap **130** that serves that optical interface **140** has filters operating at wavelengths corresponding to bandpass filter **1330** disposed in the bandwidth transforming node **120**.

Figure 14 illustrates the composite passband of all filters illustrated in Figure 13. The emission spectrum of the optical transmitters **325₁**, **325₂**, **325_n** is also shown. The figure also applies to the digital optical transmitters **685** in the subscriber optical

interfaces 140. The emission spectrum at room temperature 1400 is generally centered on the set of passbands shown. For transmitter 325₁, which is to transmit on the wavelengths labeled F1, the passbands at λ_4 and λ_7 pass the optical signal. The wavelengths are determined by filters embedded in the wavelength multiplexer/de-

5 multiplexer 440, filters 600, and spectral slicers 635, 930. These passbands 1330, 1360, 1390 are illustrated.

For the emission spectrum at high temperature 1410, the emission spectrum has shifted to higher wavelengths. Now λ_4 is not a passing signal, but λ_7 is a passing signal.

10 The emission spectrum at low temperature 1420 illustrates an exemplary scenario at low temperatures where the emission spectrum has shifted to a lower wavelength. Now λ_1 and λ_4 are passing energy, but λ_7 is not. In this way, at least one passband is available within the emission spectrum of the transmitter at all temperatures. Therefore, another advantage of assigning each subscriber a set of

15 wavelengths becomes apparent: multiple wavelengths corresponding to all subscribers served from one tap compensate for temperature fluctuations of LED digital optical transmitters. In this way, a subscriber can be guaranteed to receive his or her information.

Referring now to Figure 15, this figure illustrates an exemplary method for

20 processing unidirectional and bi-directional optical signals with a bandwidth transforming node 120 of the present invention. Basically, Figure 15 provides an overview of the processing performed by the bandwidth transforming node 120.

Certain steps in the process described below must naturally precede others for the present invention to function as described. However, the present invention is not

25 limited to the order of the steps described if such order or sequence does not alter the functionality of the present invention. That is, it is recognized that some steps may be performed before or after other steps without departing from the scope and spirit of the present invention.

Step **1505** is the first step in the exemplary bandwidth transforming node overview process **1500**. In Step **1505**, downstream RF modulated optical signals can be amplified by the amplifier **410** as illustrated in Figure 4. As noted above, amplifiers **330**, **410** can comprise Erbium Doped Fiber Amplifiers (EDFAs).
5 However, other optical amplifiers are not beyond the scope of the present invention. The amplified optical signals can then propagate to one or more optical taps **130**.

Next, in routine **1510**, downstream targeted services digital optical signals can be converted into electrical signals and upstream electrical signals can be converted into optical signals in a fiber transceiver **425**. The fiber transceiver **425** can comprise
10 an optical/electrical converter and an electrical/optical converter. Upstream optical signals can propagate between the bandwidth transforming node **120** and the data service hub **110**, and the downstream electrical signals can propagate from the fiber transceiver **425** to an optical tap routing device **430**. Further details of routine **1510** will be described below with respect to Figures 16 and 17.

In step **1515**, the wavelength(s) of LED optical data signals can be assigned to groups of subscribers or respective optical taps at the time of installation of the optical taps **130**. In other words, each LED optical transmitter **325** can be tuned for a distinct wavelength or wavelength region relative to other LED optical transmitters **325**. For downstream signals, the optical tap routing device **430** can manage the
20 interface with the data service hub optical signals and can route these signals to the corresponding individual tap multiplexers **435**, which communicate optical signals with particular optical taps **130**. Similarly, the optical tap routing device **430** can be notified of available upstream data packets as they arrive from each tap multiplexer **435**. Moreover, the optical tap routing device **430** can offer data bandwidth to
25 subscribers in pre-assigned increments. For example, the optical tap routing device **430** can offer a particular subscriber or groups of subscribers bandwidth in units of 1, 2, 5, 10, 20, 50, 100, 200, and 450 Megabits per second (Mb/s). Those skilled in the art will appreciate that other subscriber bandwidth units are not beyond the scope of the present invention. For example, the optical tap routing device could be capable of
30 assigning bandwidths in increments of 250 kb/s. The element management system,

which controls the subject equipment and is well known to those skilled in the art, could allow bandwidth to be assigned at 1, 10, and 100 Mb/s if that is what the data service operator wants to sell.

In Step **1520**, LED optical data signals and unidirectional LED optical signals
5 can be propagated along separate optical waveguides **150**, **170**, **180** between the bandwidth transforming node **120** and one or more optical taps **120**.

Referring now to Figure 16, this figure illustrates a logic flow diagram of an exemplary routine **1510** for handling downstream optical signals within a bandwidth transforming node **120** according to the present invention. More specifically, the
10 logic flow diagram of Figure 16 illustrates a first portion of the exemplary routine **1510** for communicating optical signals from a data service provider **110** to at least one subscriber.

As noted above, certain steps in the process described below must naturally proceed others for the present invention to function as described. However, the
15 present invention is not limited to the order of steps described if such order or sequence does not alter the functionality of the present invention. That is, it is recognized that some steps may be performed before or after other steps without departing from the scope and spirit of the present invention.

Step **1620** is the first step in routine **1510** for communicating optical signals
20 from a data service provider **110** to at least one subscriber. In Step **1620**, the optical tap routing device **430** can direct downstream electrical data signals to a multiplexer **435** assigned to a subscriber group or optical tap **130**. As described above, the optical tap routing device **430** can manage the interface with the data service hub optical signals and can route these signals to the corresponding individual tap multiplexers
25 **435** that communicate optical signals with particular optical taps **130**. Next in Step **1620**, the downstream electrical data signals can be processed within each multiplexer **435**. The tap multiplexers **435** can propagate optical signals to the various groupings of subscribers.

The one or more tap multiplexers **435** can propagate downstream electrical signals to one or more LED optical transmitters **325**. The LED optical transmitters **325** can produce the downstream optical signals that propagate towards the subscriber optical interfaces **140**. In Step **1640**, the downstream electrical data signals are converted into downstream LED optical data signals by the LED optical transmitters **325**. These signals propagate between the LED optical transmitters **325** and a bi-directional splitter **360**.

Next in Step **1650**, the bi-directional splitter **360** can propagate downstream LED optical data signals originating from individual multiplexers **435** along separate optical waveguides to one or more wavelength division multiplexers **440, 500, 510**. Next in Step **1670**, once the downstream signals propagate from the bi-directional splitter **360** to the wavelength division multiplexer **440, 500** the wavelength division multiplexer **440, 500** can combine or multiplex the wavelengths of light that propagate from each LED optical transmitter **325**. It is here that wavelengths are selected by the internal filter structure illustrated in **1330, 1360, and 1390**.

Figure 17 illustrates a logic flow diagram illustrating the handling of upstream data signals within an exemplary bandwidth transforming node **120** of the present invention. More specifically, Figure 17 illustrates a second portion of routine **1510** for communicating optical signals from at least one subscriber to a data service provider hub **110**.

As noted above, certain steps in the process described below must naturally proceed others for the present invention to function as described. However, the present invention is not limited to the order of the steps described if such order or sequence does not alter the functionality of the present invention. That is, it is recognized that some steps may be performed before or after other steps without departing from the scope and spirit of the present invention.

Step **1710** is the first step in the exemplary bandwidth transforming node upstream routine **1510**. In Step **1710**, multiplexed upstream LED optical data signals from optical taps **130** are disassembled into separate LED optical data signals of assigned wavelengths by one or more wavelength division de-multiplexers **440, 510**.

Each wavelength division de-multiplexer **440, 510** can select a different wavelength or wavelengths of light that propagate from a respective optical tap **130**.

In Step **1720** LED optical data signals of assigned wavelengths are fed into separate optical waveguides by the wavelength division de-multiplexer **440, 510**.

5 In Step **1730**, upstream LED optical data signals can be converted by an optical receiver **370** into electrical signals. Each optical receiver **370** can comprise one or more photoreceptors or photodiodes that convert optical signals into the electrical domain.

10 In Step **1740**, upstream electrical data signals can be processed with respective subscriber assigned multiplexers **435**. The multiplexers **435** can notify the optical tap routing device **430** of available upstream data packets as they arrive.

In Step **1750**, processed upstream electrical data signals can be combined in the optical tap routing device **430**. In Step **1760**, upstream electrical data signals can be converted to upstream optical data signals by the fiber transceiver **425**. Next, in
15 Step **1770**, the optical data signals can be fed into an optical waveguide **160** by the fiber transceiver **425**.

Figure 18 is a logic flow diagram illustrating the processing of unidirectional and bi-directional data signals with an optical tap **130** according to the present invention. As noted above, certain steps in the process described below must
20 naturally proceed others for the present invention to function as described. However, the present invention is not limited to the order of steps described if such order or sequence does not alter the functionality of the present invention. That is, it is recognized that some steps may be performed before or after other steps without departing from the scope and spirit of the present invention.

25 Step **1810** is the first step in the optical tap process **1800**. In Step **1810**, an optical coupler **620** channels or taps unidirectional optical signals from an optical waveguide **150** that propagate from a bandwidth transforming node **120** or another optical tap **130**. The optical coupler **620** can extract signal power from the broadcast

waveguide **150** and route the extracted signal to an optical diplexer **625** or to another optical tap **130**.

Next, in Steps **1820, 1830**, a spectral slicer **635** extracts or reflects optical signals that propagate from the bandwidth transforming node **120** or another optical tap **130** to the optical tap **130** via a targeted services waveguide **170**. In Step **1830**, the spectral slicers **635** can extract a set of subscriber assigned wavelengths from the LED optical data signals. In Step **1840**, the optical tap **130** propagates the assigned wavelength(s) of LED optical data signals and unidirectional signals to respective subscribers via a subscriber optical interface **140**.

Figure 19 is a logic flow diagram illustrating exemplary processing of unidirectional and bi-directional data signals with a subscriber optical interface **140** according to the present invention. As noted above, certain steps in the process described below must naturally proceed others for the present invention to function as described. However, the present invention is not limited to the order of steps described if such order or sequence does not alter the functionality of the present invention. That is, it is recognized that some steps may be performed before or after other steps without departing from the scope and spirit of the present invention.

Step **1910** is the first step in the subscriber optical interface process **1900**. In Step **1910**, unidirectional electrical signals are received by the optical subscriber interface **140** by an analog optical receiver **660**. However, if the analog optical receiver **660** is located in the optical tap **130**, this step can be performed earlier in Step **1800**. The analog optical receiver **660** converts the electrical signals and sends them to one or more subscribers. Next, in Step **1920**, downstream LED optical data signals of assigned wavelength(s) can be received by the subscriber optical interface **140**. In Step **1930**, downstream LED optical data signals of assigned wavelength(s) can be converted to downstream electrical data signals by a digital optical receiver **675** in the subscriber optical interface **140**. In Step **1940**, upstream electrical data signals can be converted to upstream LED optical data signals in the subscriber optical interface **140** by a digital optical transmitter **685**. In Step **1950**, downstream electrical data signals can be received and upstream electrical data signals can be

generated with one or more of a telephone device **690** and computing device **695** by a processor **680**.

Those skilled in the art will appreciate that the optical network architecture **100** of the present invention can provide at least one of video, telephone, and computer communication services via the optical signals. Also, those skilled in the art will appreciate that the video layer comprising the RF modulated signals can be removed from the exemplary optical network architecture **100** without departing from the scope and spirit of the present invention.

With the present invention, an all fiber optical network and method that can propagate the same bit rate downstream and upstream to/from a network subscriber are provided. Further, the present invention provides an optical network system and method that can service a large number of subscribers while reducing the number of connections at the data service hub.

The present invention also provides an active signal source that can be disposed between a data service hub and a subscriber and that can be designed to withstand outdoor environmental conditions. The present invention can also be designed to hang on a strand or fit in a pedestal similar to conventional cable TV equipment that is placed within a last mile of a communications network. The system and method of the present invention can receive at least one Gigabit or faster Ethernet communications in optical form from a data service hub and partition or apportion this optical bandwidth into distribution groups of a predetermined number.

The system and method of the present invention can allocate additional or reduced bandwidth based upon the demand of one or more subscribers on an optical network. Additionally, the optical network system of the present invention lends itself to efficient upgrading that can be performed entirely on the network side. In other words, the optical network system allows upgrades to hardware to take place in locations between and within a data service hub and an active signal source disposed between the data service hub and a subscriber.

And lastly, by using multiple sets of wavelengths for each subscriber grouping or optical tap **130**, the present invention enables simultaneous transmissions of

upstream optical signals from a plurality of subscriber groupings or optical taps **140** that are coupled to the same optical waveguide, unlike the conventional art. In this way, not only are transmission speeds substantially increased, but bandwidth is substantially increased. Further, by assigning each subscriber a separate and distinct
5 wavelength or wavelength region relative to other subscribers, carrier sense or the staggering of upstream or downstream transmissions between respective subscriber optical interfaces coupled to the same optical tap **130** can be substantially reduced or eliminated.

It should be understood that the foregoing relates only to illustrate the
10 embodiments of the present invention, and that numerous changes may be made therein without departing from the scope and spirit of the invention as defined by the following claims.

CLAIMS

What is claimed is:

- 5 1. An optical network system comprising
 a data service hub;
 at least one optical tap, the optical tap further comprising a spectral
 slicer for extracting wavelengths of downstream optical signals and for combining
 upstream optical signals;
10 at least one subscriber optical interface connected to the optical tap for
 receiving the extracted wavelengths of downstream optical signals and for sending
 upstream optical signals;
 a bandwidth transforming node disposed between the data service hub
 and the optical tap, for propagating upstream and downstream optical signals
15 comprising a plurality of wavelengths;
 one or more optical waveguides connected between respective optical
 taps and the bandwidth transforming node, for carrying the upstream optical signals
 and the downstream optical signals, whereby the number of the waveguides is
 minimized while optical bandwidth for subscribers is controllable by the bandwidth
20 transforming node in response to subscriber demand.
2. The optical network system of claim 1, further comprising a plurality
 of subscribers and wherein each subscriber is assigned similar wavelength.
- 25 3. The optical network system of claim 1, wherein the slicer reflects
 upstream optical signals received from one or more subscribers.
4. The optical network system of claim 1, wherein the slicer comprises an
 optical filter that reflects a tuned wavelength region while passing wavelengths
30 outside the tuned wavelength region.

5. The optical network system of claim 1, further comprising a plurality of subscriber optical interfaces, wherein the subscriber optical interfaces can simultaneously transmit upstream optical signals.

5

6. The optical network system of claim 1, wherein the bandwidth transforming node further comprises at least one wavelength division multiplexer.

7. The optical network system of claim 1, wherein the bandwidth transforming node further comprises at least one wavelength division de-multiplexer.

10

8. The optical network system of claim 1, wherein the bandwidth transforming node further comprises an optical tap routing device for apportioning the bandwidth between subscribers of the optical network system.

15

9. The optical network system of claim 1, wherein the bandwidth transforming node further comprises:

at least one multiplexer coupled to an optical tap routing device;

20

at least one optical transmitter connected to the at least one multiplexer, for transmitting downstream optical signals received from the data service hub to at least one subscriber optical interface of the optical network system; and

25

at least one optical receiver connected to each multiplexer, for receiving and converting upstream optical signals from at least one subscriber optical interface of the optical network system.

10. The optical network system of claim 1, wherein the bandwidth transforming node accepts gigabit Ethernet optical signals from the data service hub and partitions the Ethernet optical signals into a predetermined number of groups.

30

11. The optical network system of claim 1, wherein the bandwidth transforming node is mountable on a strand in an overhead plant environment.

12. The optical network system of claim 1, wherein the bandwidth
5 transforming node is housed within a pedestal in an underground plant environment.

13. The optical network system of claim 1, wherein the bandwidth transforming node further comprises an optical tap routing device that allocates additional or reduced optical bandwidth to at least one subscriber optical interface
10 relative to other subscriber optical interfaces in the optical network system.

14. The optical network system of claim 1, wherein the bandwidth transforming node comprises an optical tap routing device that manages upstream and downstream optical signal protocols.
15

15. The optical network system of claim 1, wherein data bit rates for the upstream and downstream optical signals are substantially symmetrical.

16. The optical network system of claim 1, wherein each optical tap
20 comprises at least one optical splitter.

17. The optical network system of claim 1, wherein one of the optical taps servicing a particular group of subscriber optical interfaces is connected to another optical tap.

18. A method for communicating optical signals from at least one subscriber to a data service provider comprising the steps of:

transmitting upstream optical signals from a first optical tap, the first optical tap selecting a first set of wavelengths;

5 transmitting upstream optical signals from a second optical tap, the second optical tap selecting a second set of wavelengths different from the first set of wavelengths;

receiving the upstream optical signals at a bandwidth transforming node from the first and second optical taps;

10 converting the upstream optical signals to electrical signals at the bandwidth transforming node;

combining upstream electrical signals in the bandwidth transforming node;

15 apportioning bandwidth for the first and second subscriber in the bandwidth transforming node;

converting the combined upstream electrical signals into optical signals; and

propagating the combined upstream optical signals to the data service provider along at least one optical waveguide.

20

19. The method of claim 18, wherein the steps of transmitting upstream optical signals from the first and second optical tap occur simultaneously.

20. The method of claim 18, further comprising the step of combining 25 respective upstream optical signals originating from a plurality of subscriber optical interfaces with at least one optical tap.

21. The method of claim 18, further comprising the step of feeding the first optical tap with optical signals from the second optical tap.

30

22. The method of claim 18, further comprising the step of maintaining substantially symmetrical data bit rates between the downstream optical signals and the upstream optical signals.

23. A method for communicating optical signals from a data service provider to at least one subscriber comprising the steps of:

receiving downstream optical signals in a bandwidth transforming node from the service provider;

5 dividing the downstream signals between preassigned multiplexers in the bandwidth transforming node, the preassigned multiplexers corresponding to a grouping of subscribers;

 multiplexing the downstream signals at the preassigned multiplexers;

 assigning different wavelength regions for groups of optical taps ;

10 generating the wavelength regions for each of said groups of optical taps;

 apportioning bandwidth between subscribers in the bandwidth transforming node;

 multiplexing the sets of wavelengths corresponding to optical taps
15 together; and

 propagating respective combined downstream optical signals to at least one subscriber along at least one optical waveguide.

24. The method of claim 23, wherein the step of receiving downstream optical signals further comprises the substep of receiving at least one of an Ethernet
20 and SONET optical signal from the data service provider.

25. The method of claim 23, further comprising the step of providing one of video, telephone, and internet services via the optical signals.

25

26. The method of claim 23, further comprising the steps of:

extracting selected wavelengths from the downstream optical signals with at least one optical tap; and

propagating the sliced downstream optical signals to at least one
30 subscriber along at least one optical waveguide.

27. The method of claim 23, further comprising the step of feeding one optical tap with optical signals from another optical tap.

28. The method of claim 23, wherein the step of apportioning bandwidth
5 further comprises the step of allocating additional or reduced optical bandwidth for at least one particular subscriber optical interface relative to other subscriber optical interfaces in the optical network system.

29. The method of claim 23, further comprising the steps of:
10 compensating for shifts in an optical transmitter output due to temperature fluctuations by generating sets of wavelengths with the optical transmitter; and
assigning each set of wavelengths to a particular optical tap.

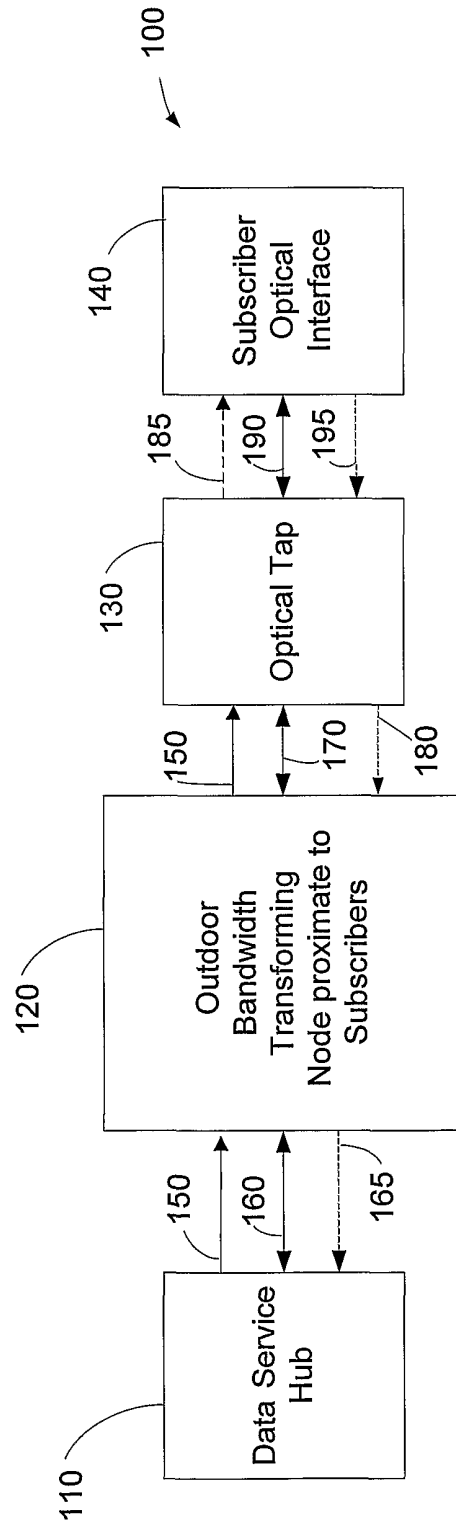

FIG. 1

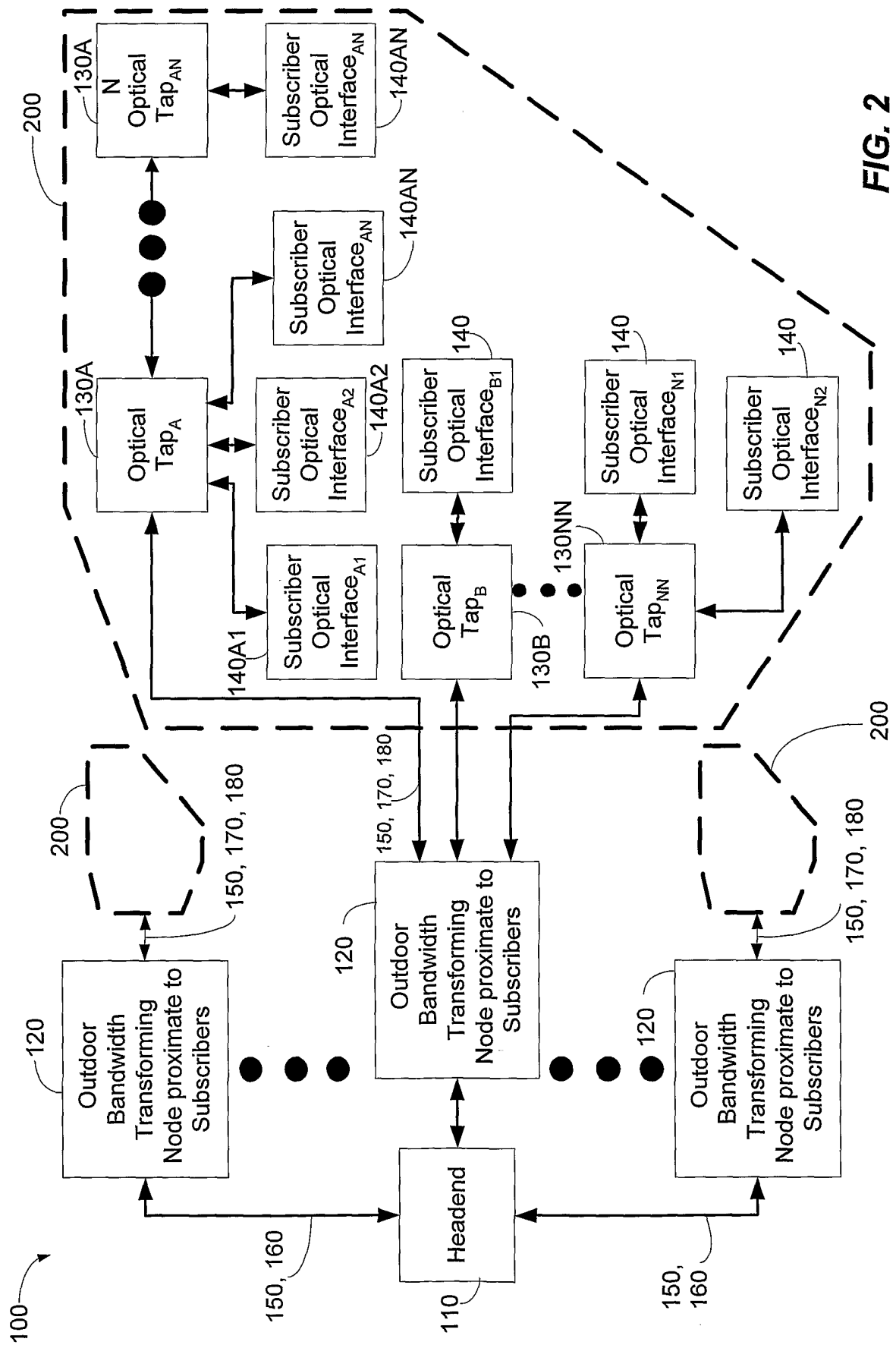

FIG. 2

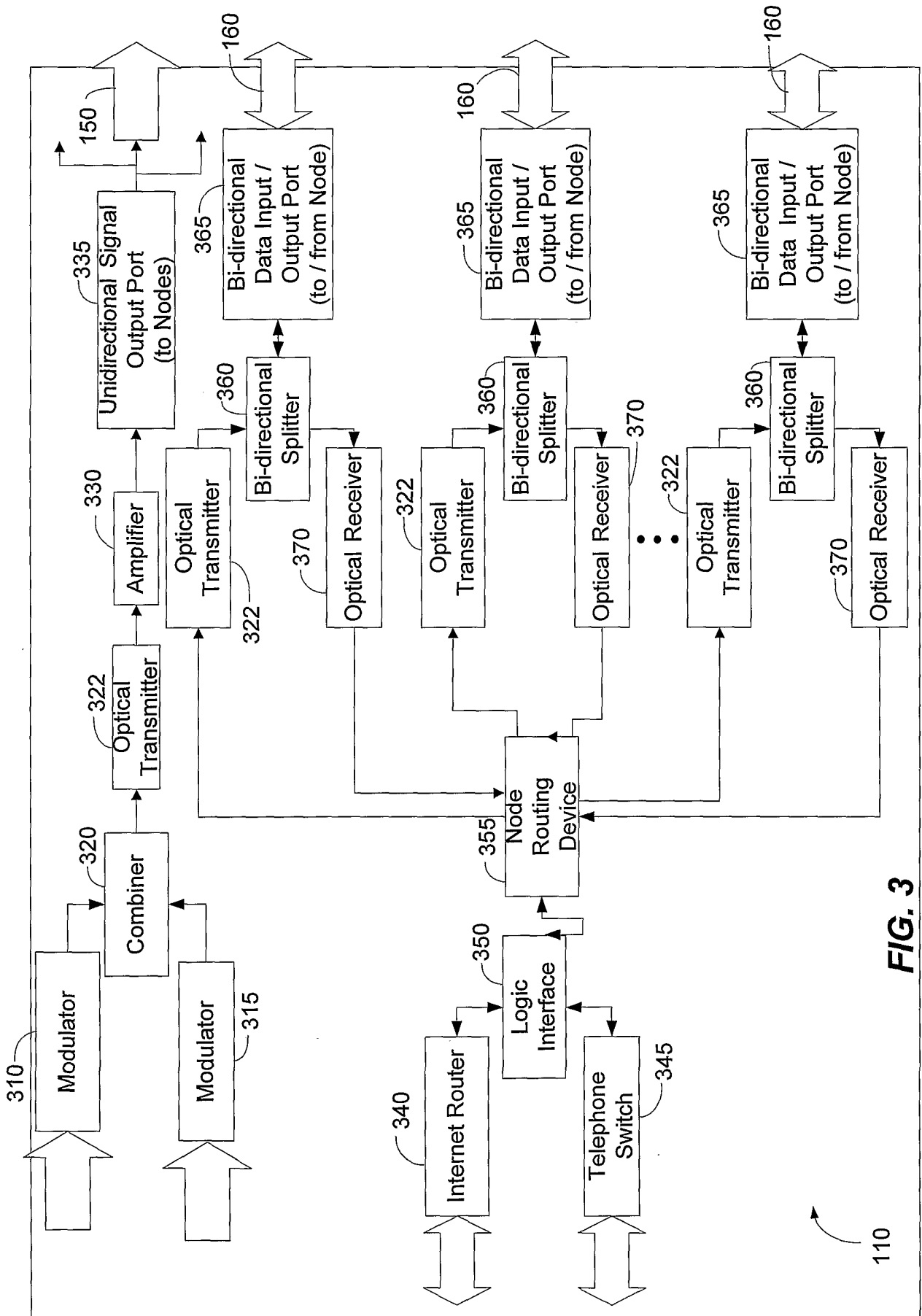

FIG. 3

110

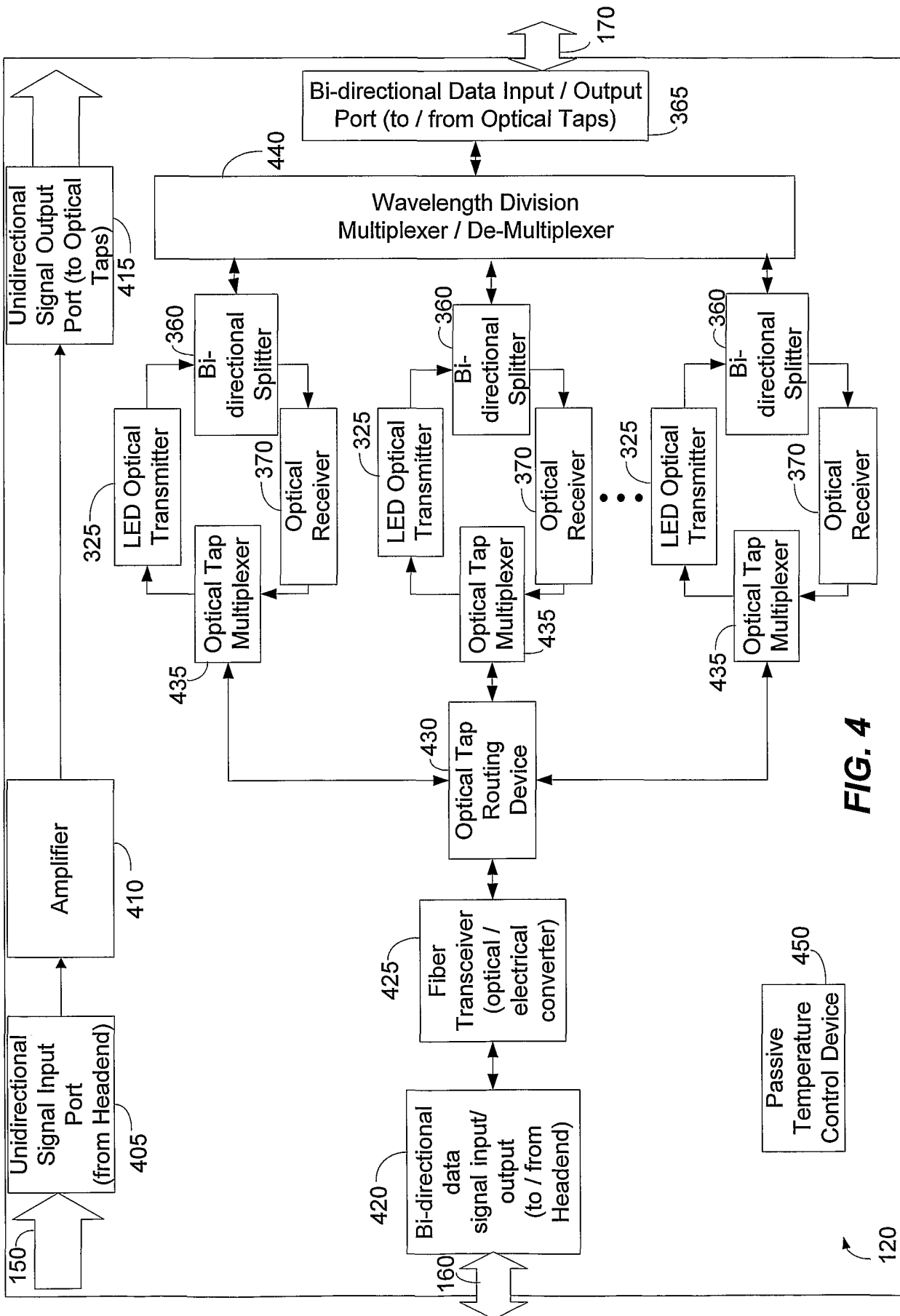

FIG. 4

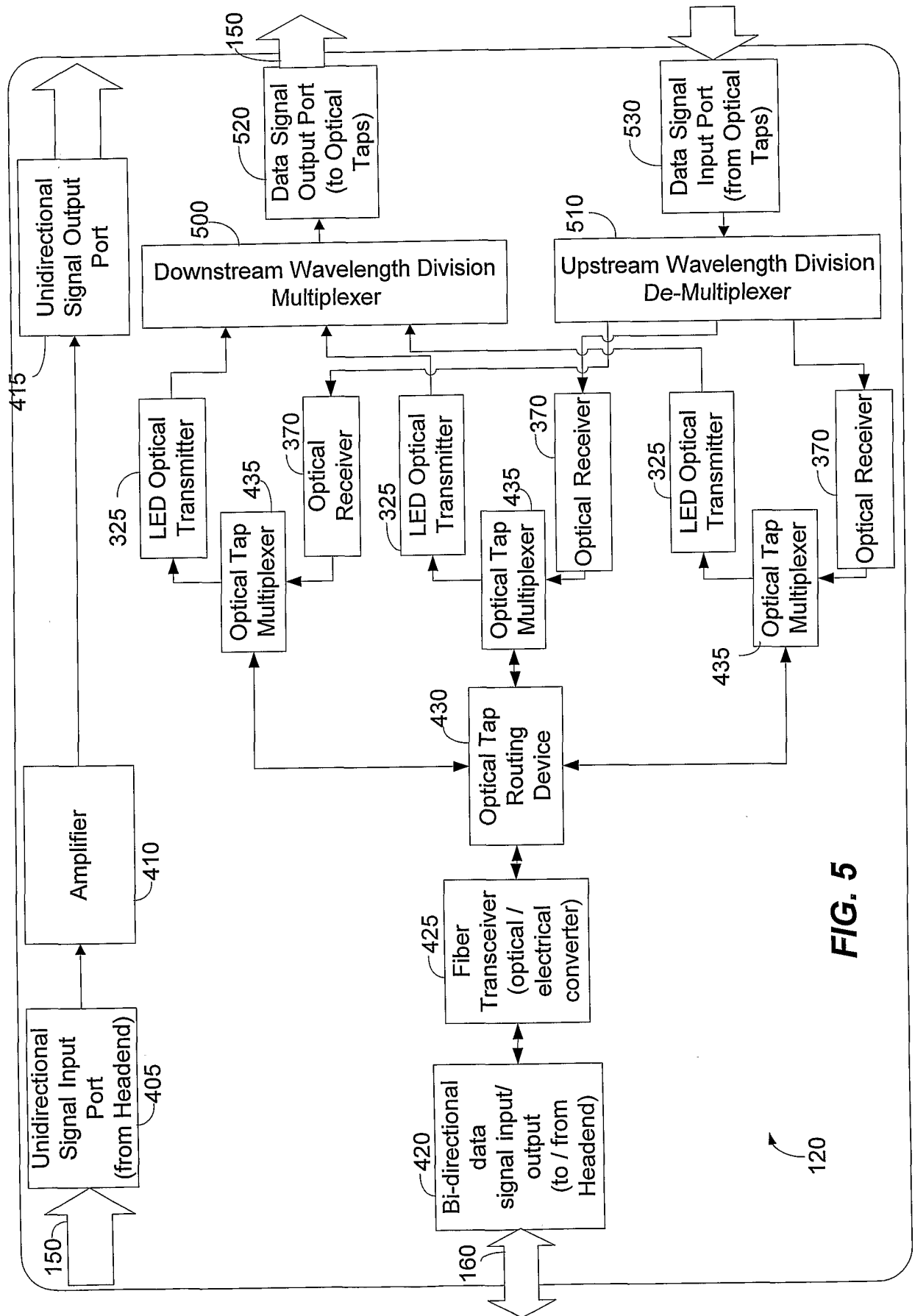

FIG. 5

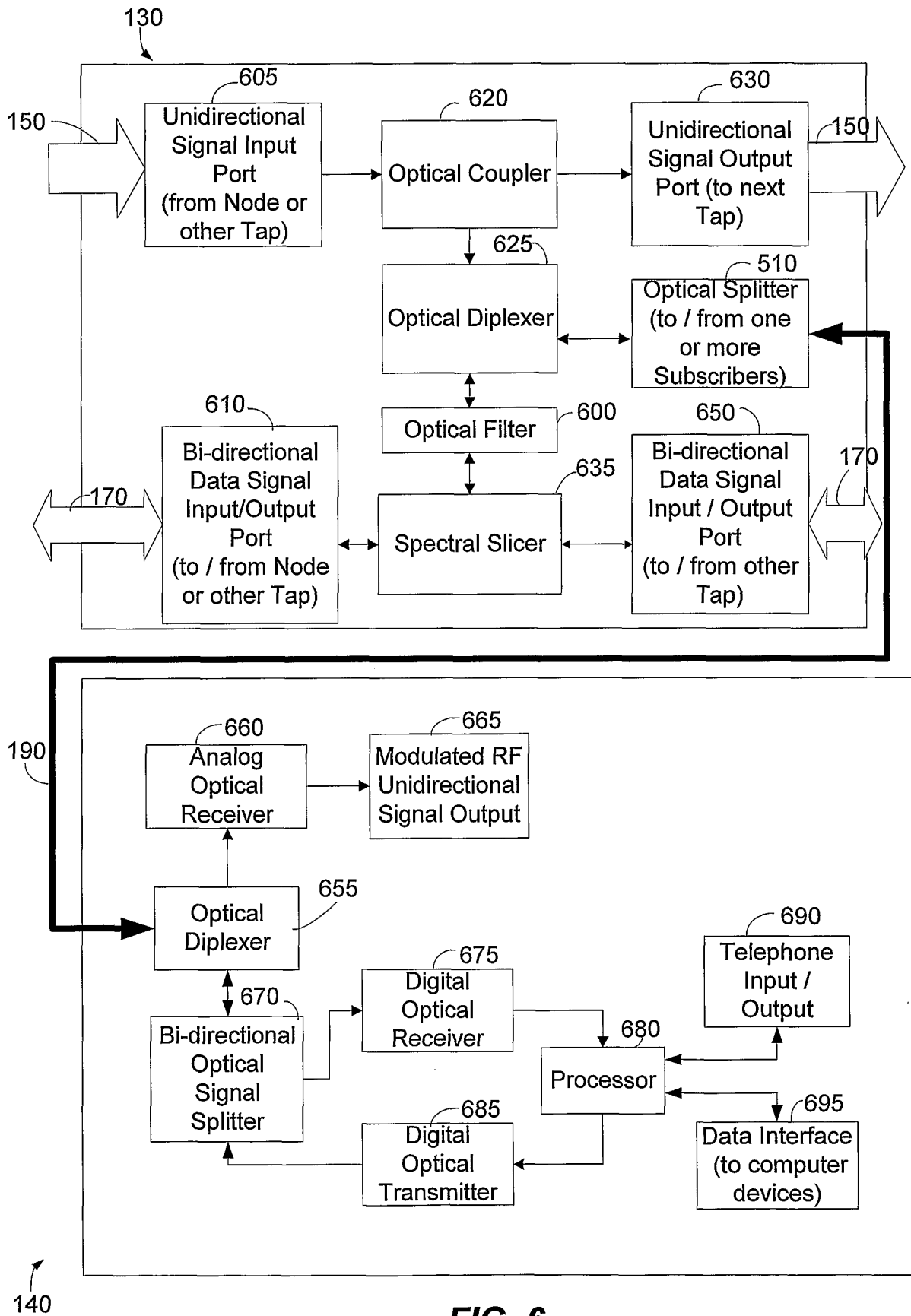

FIG. 6

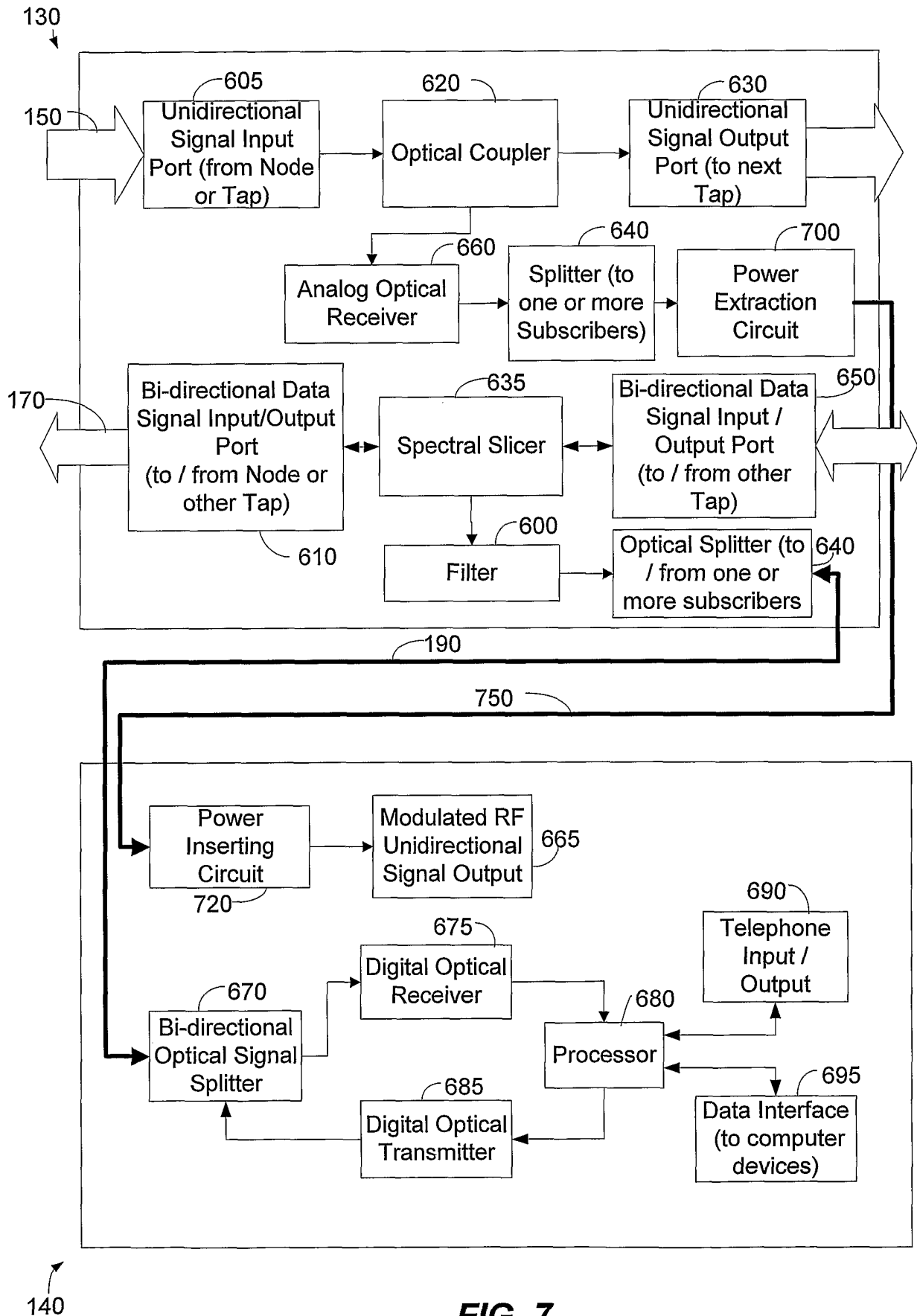

FIG. 7

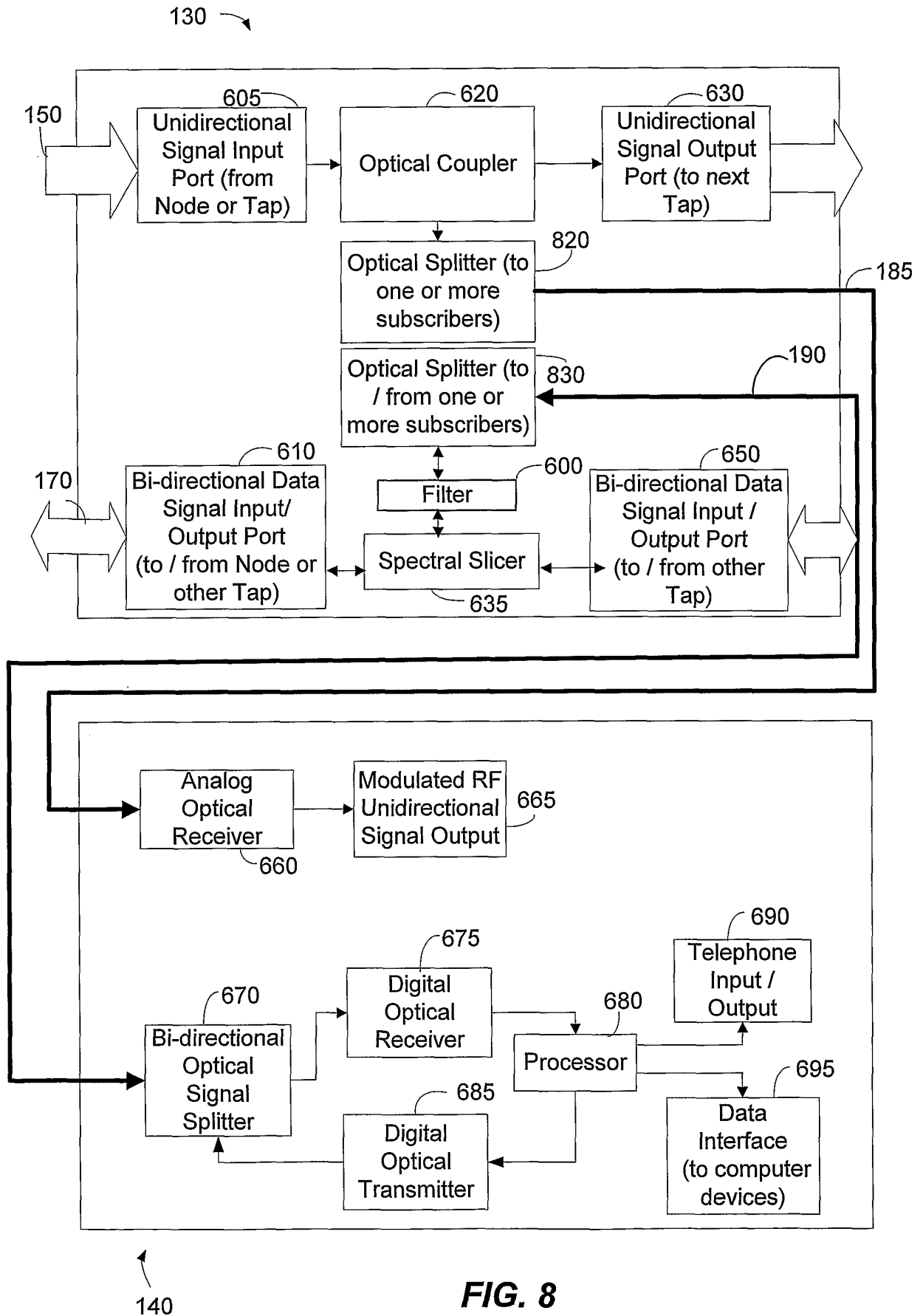

FIG. 8

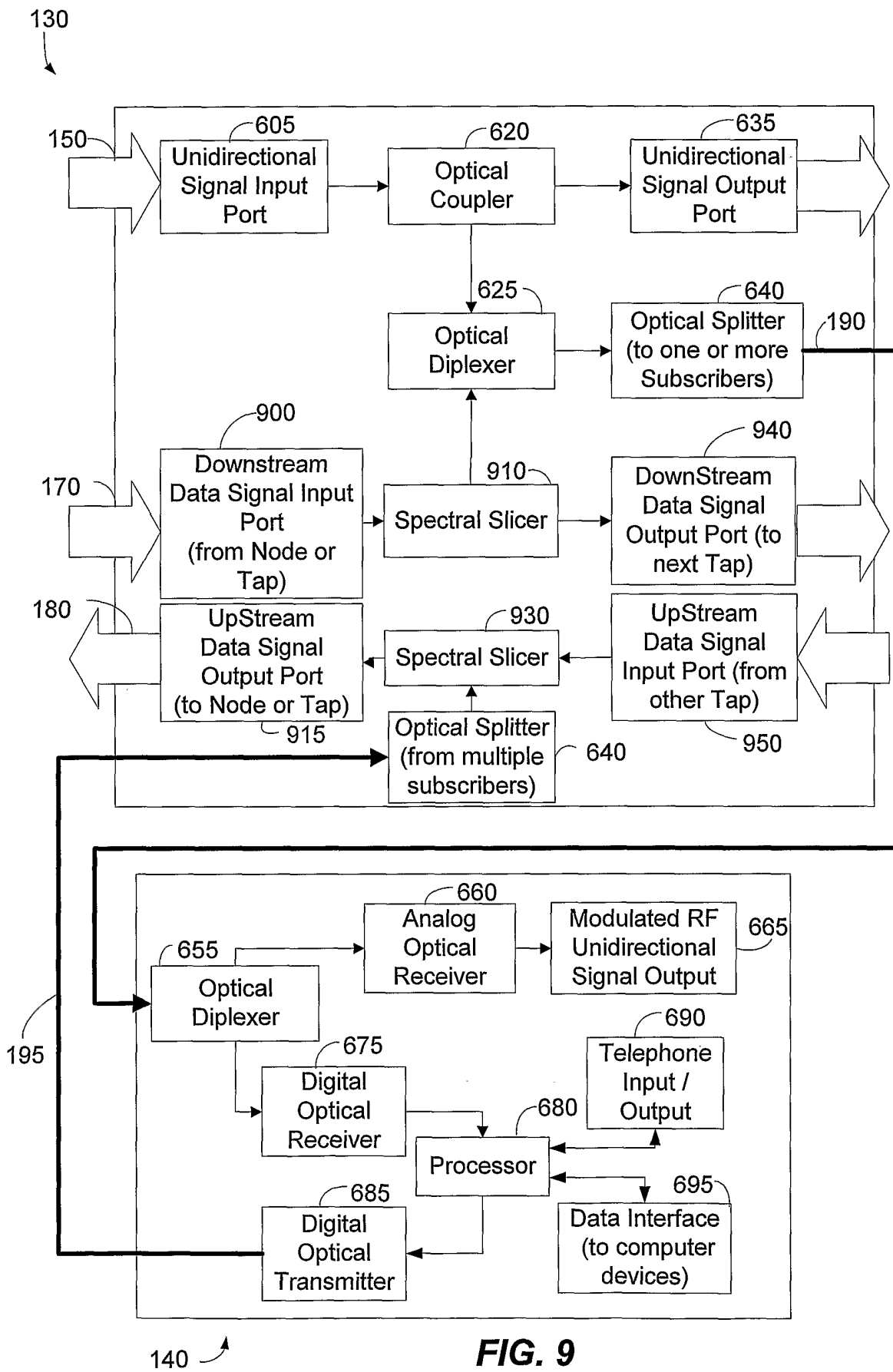

FIG. 9

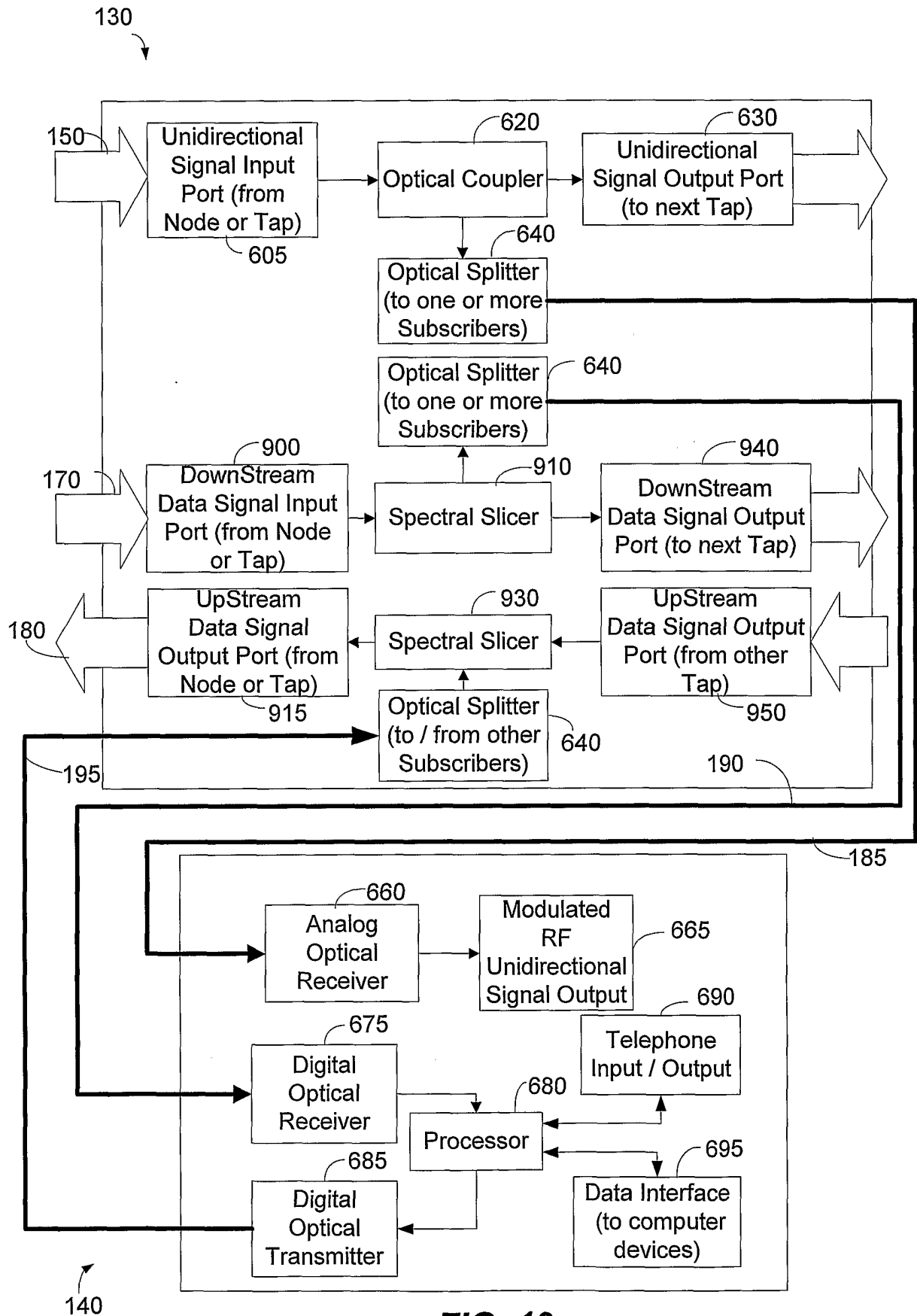

FIG. 10

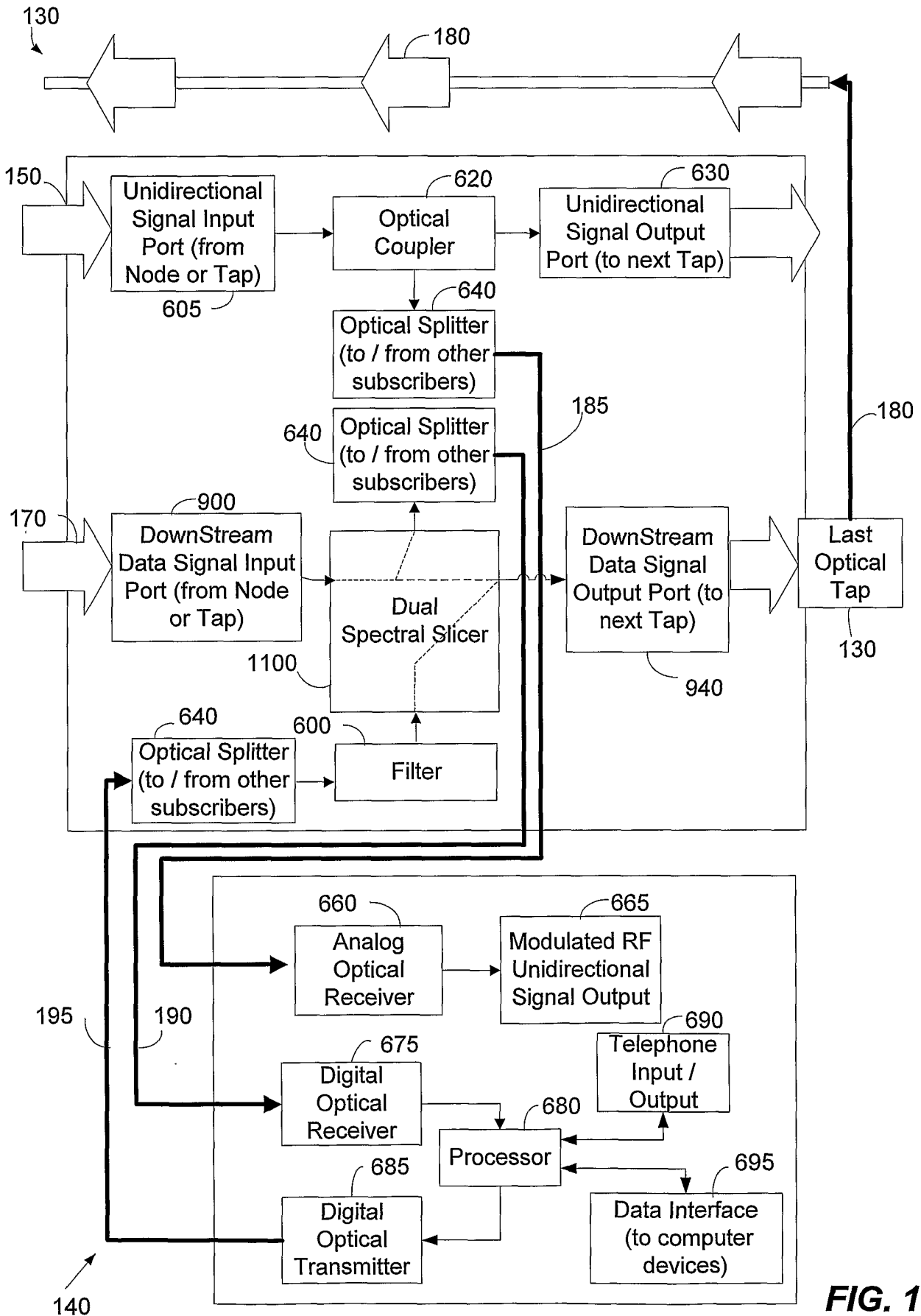

FIG. 1

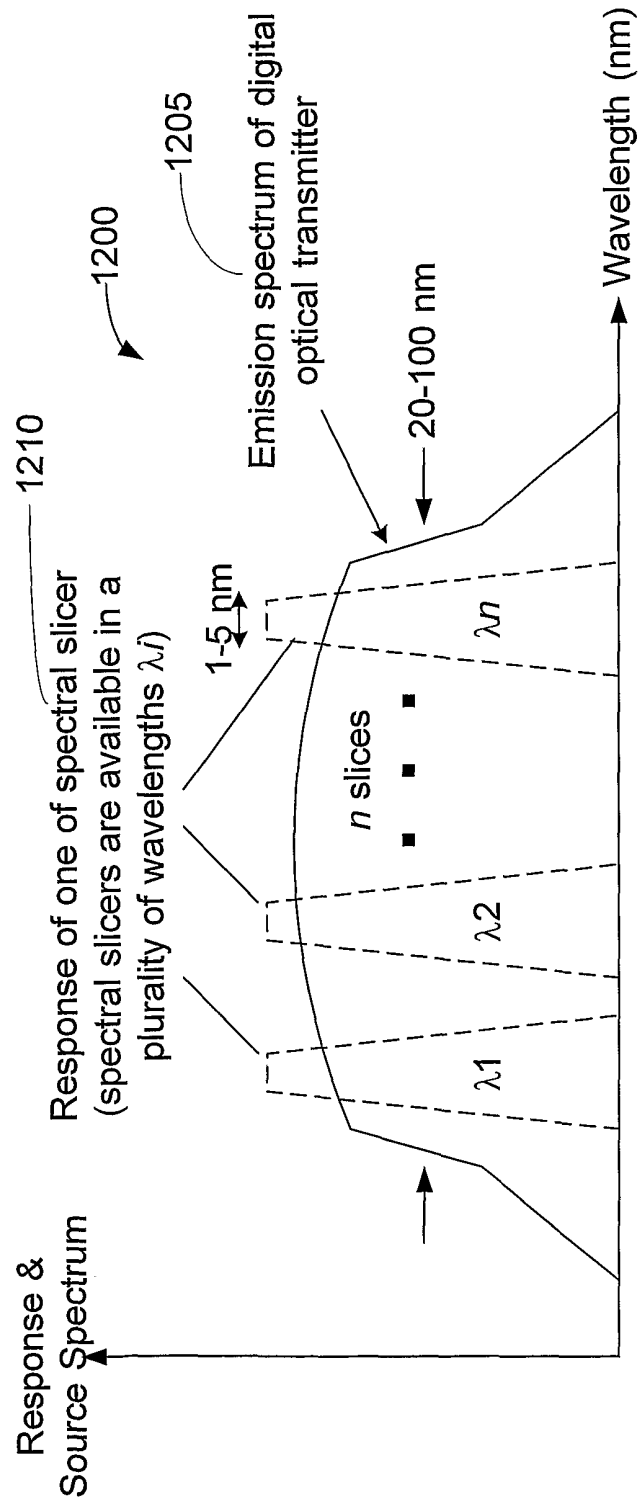

FIG. 12A

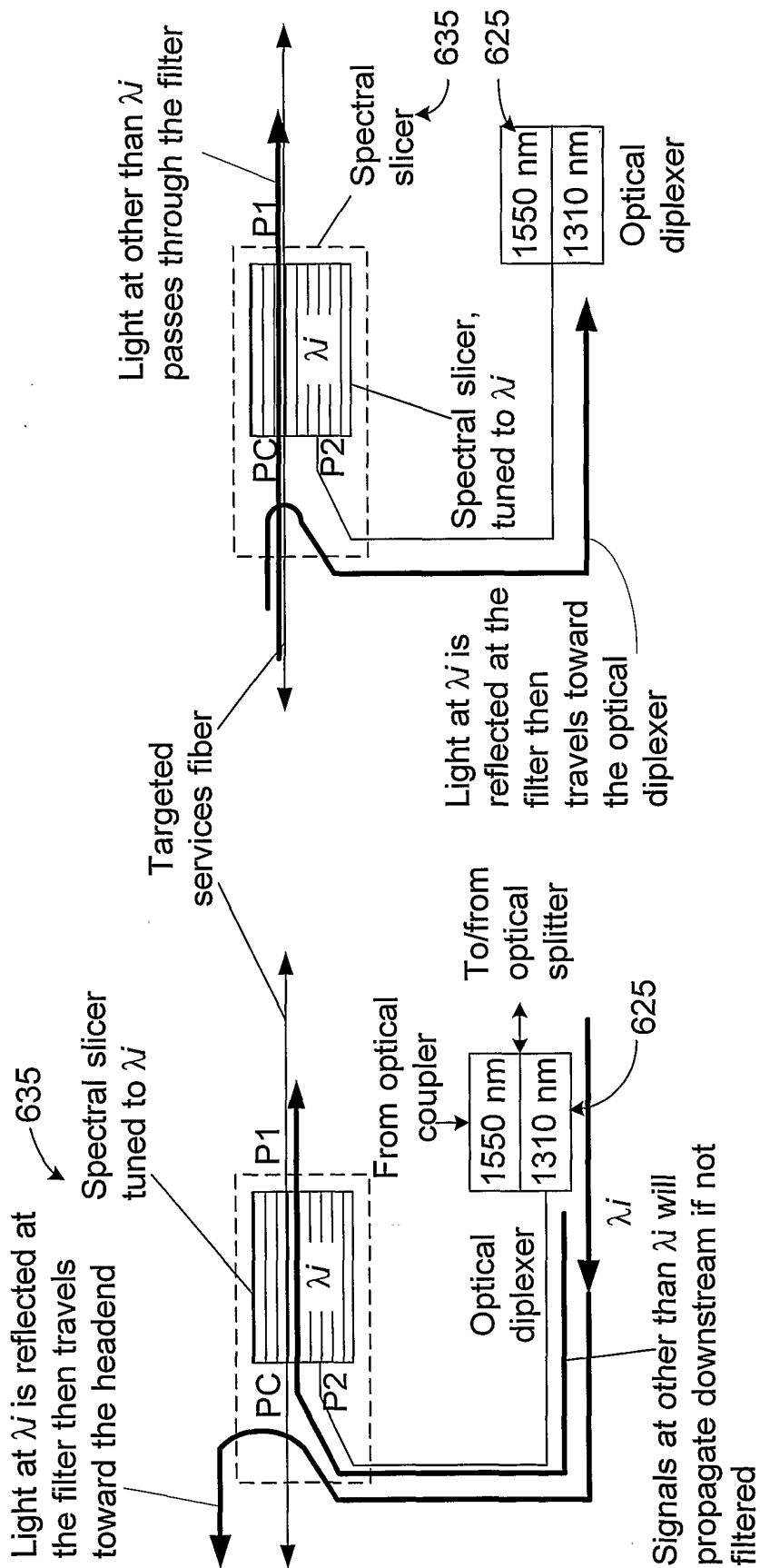

FIG. 12C

FIG. 12B

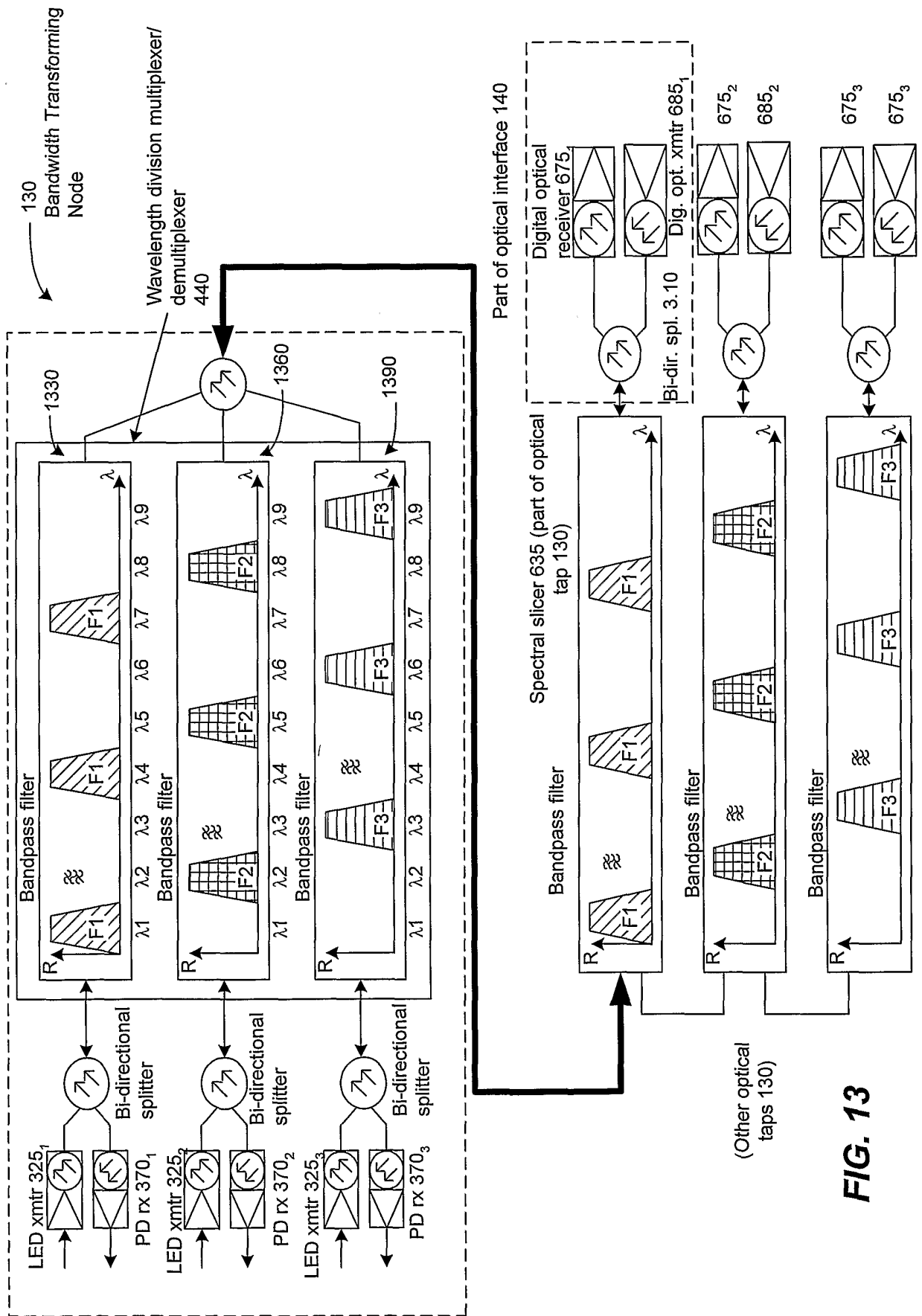

FIG. 13

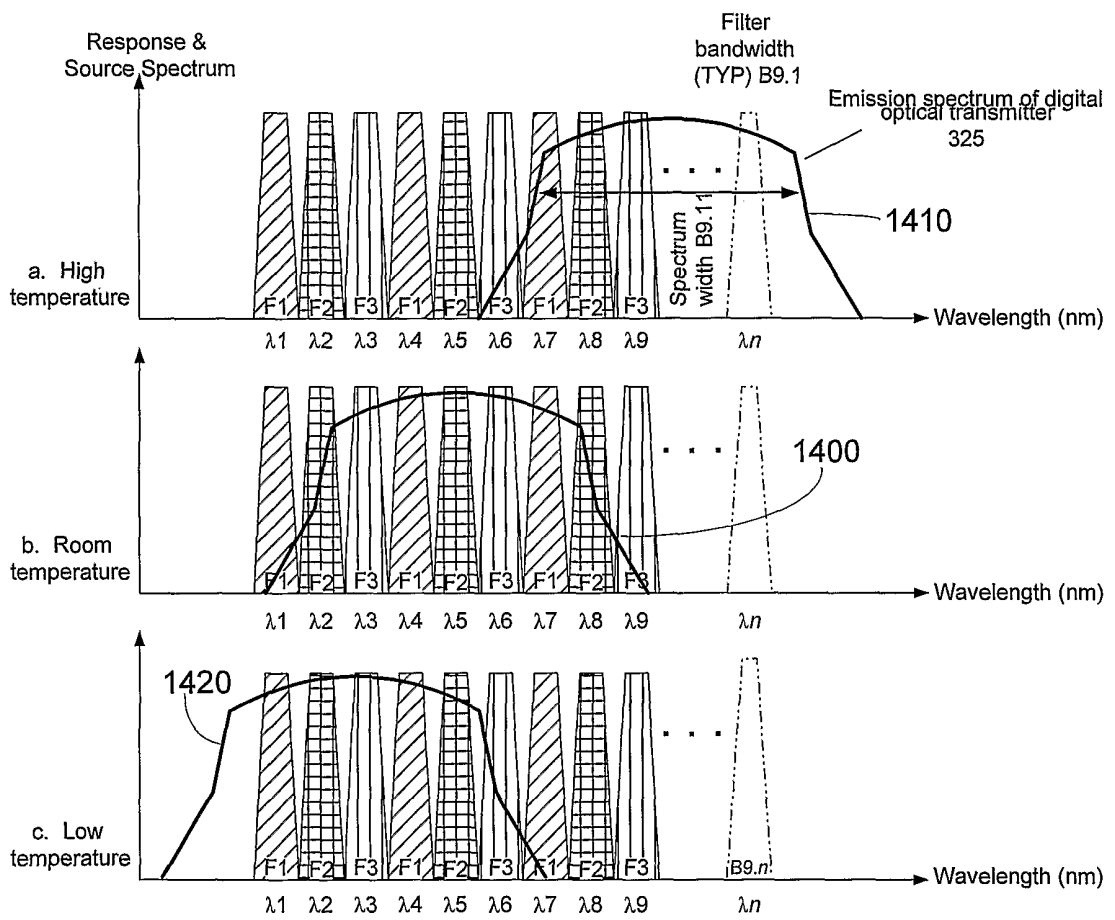

FIG. 14

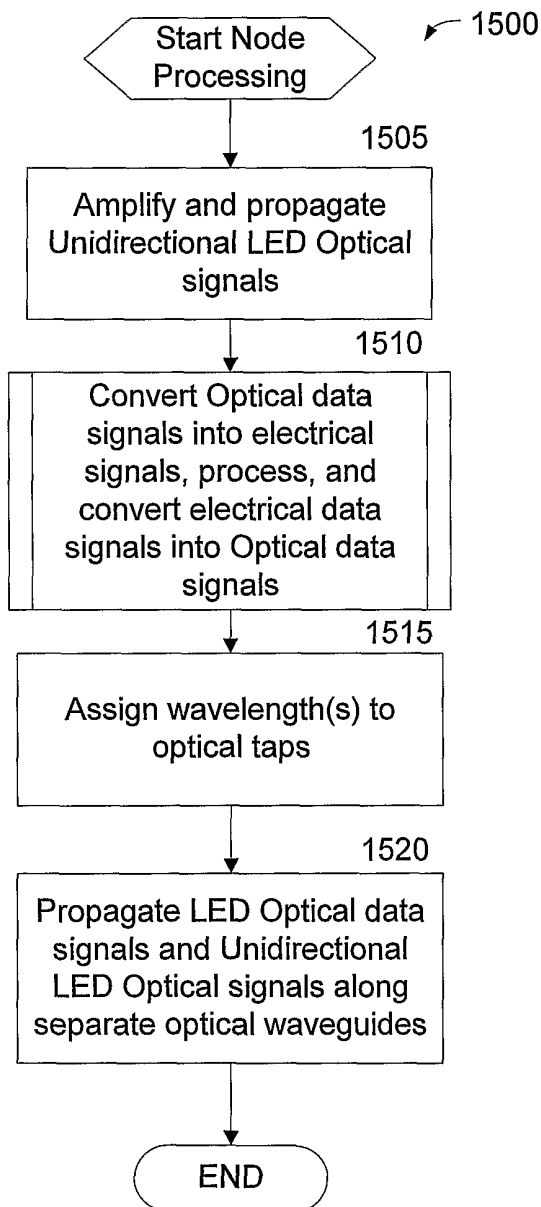

FIG. 15

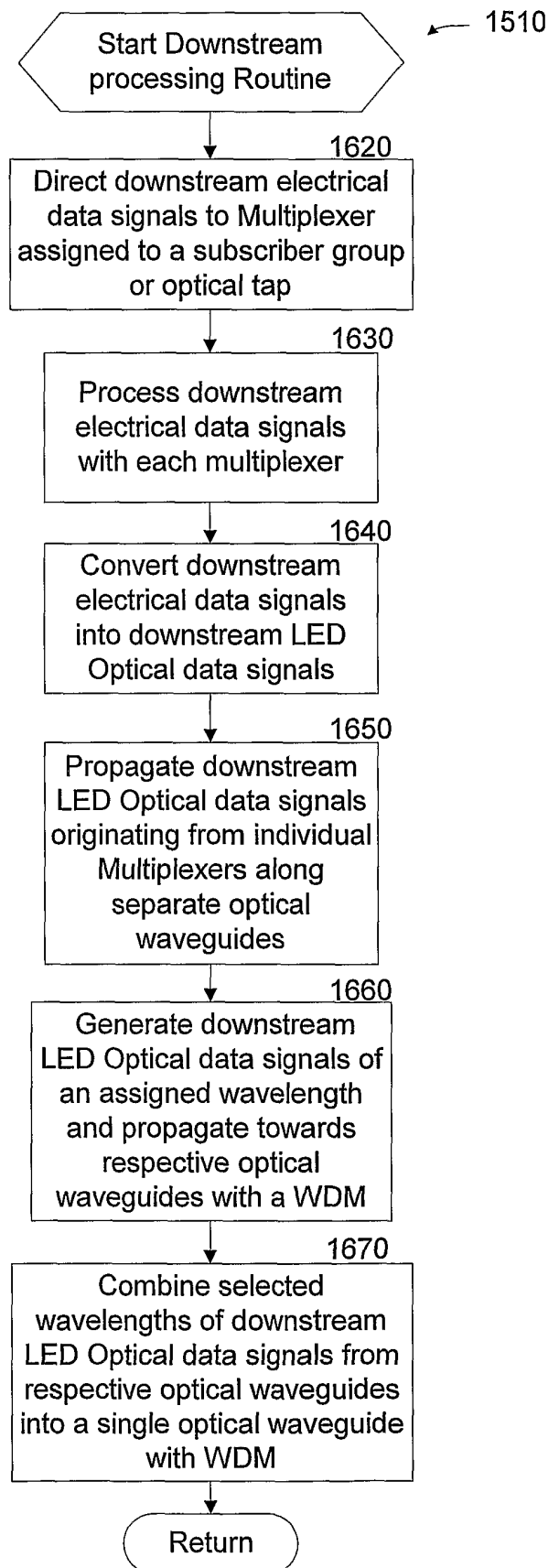

FIG. 16

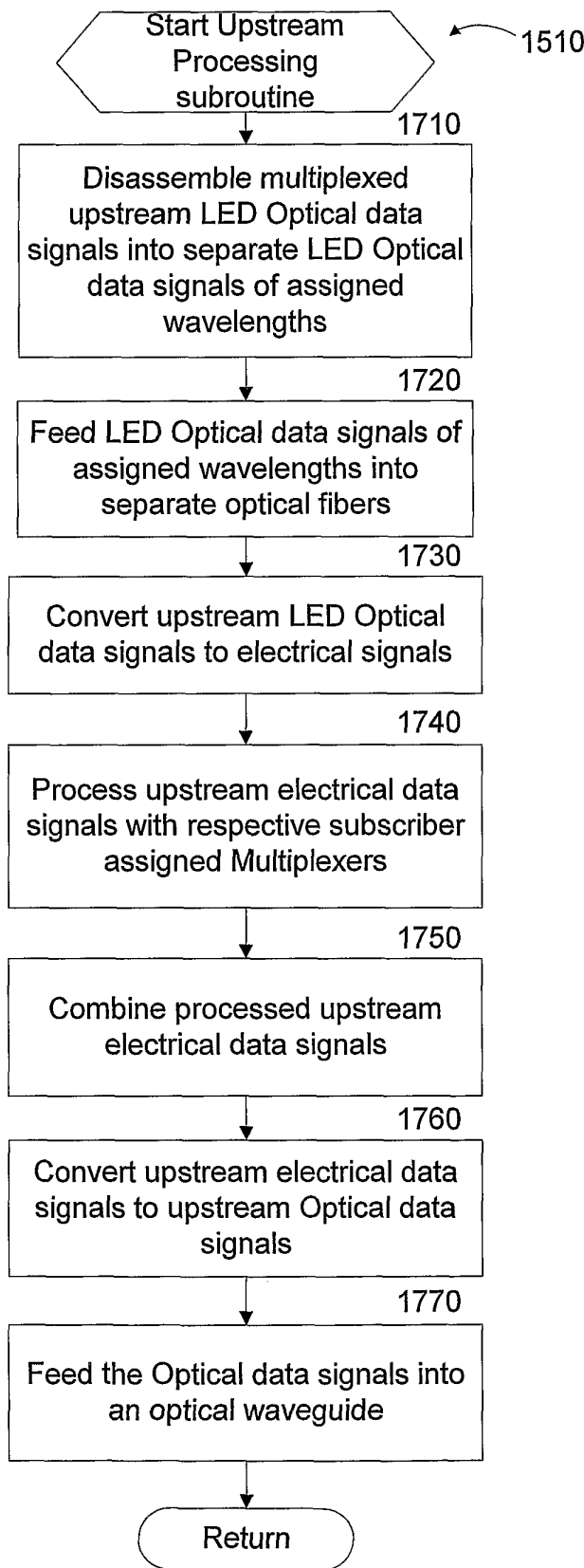

FIG. 17

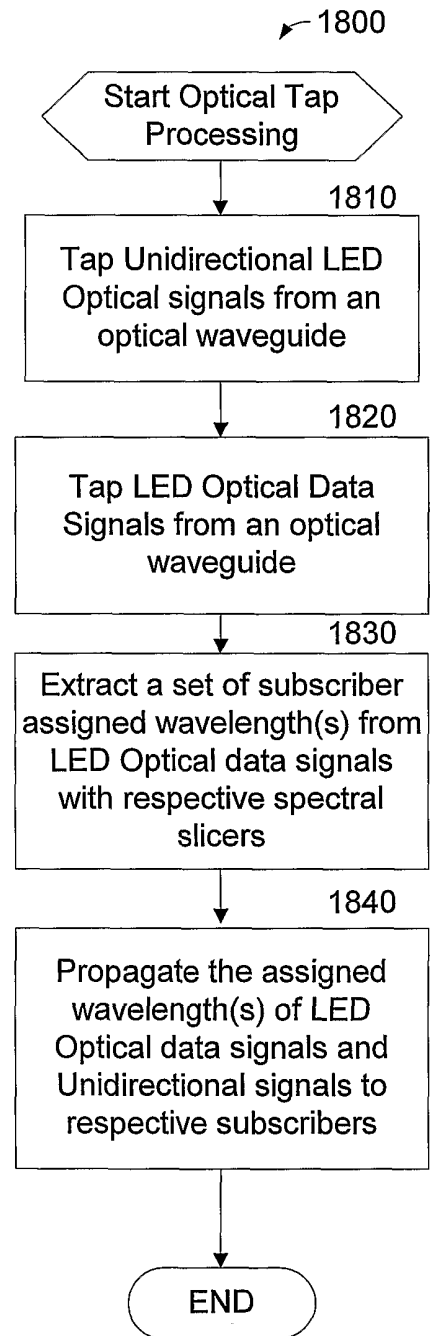

FIG. 18

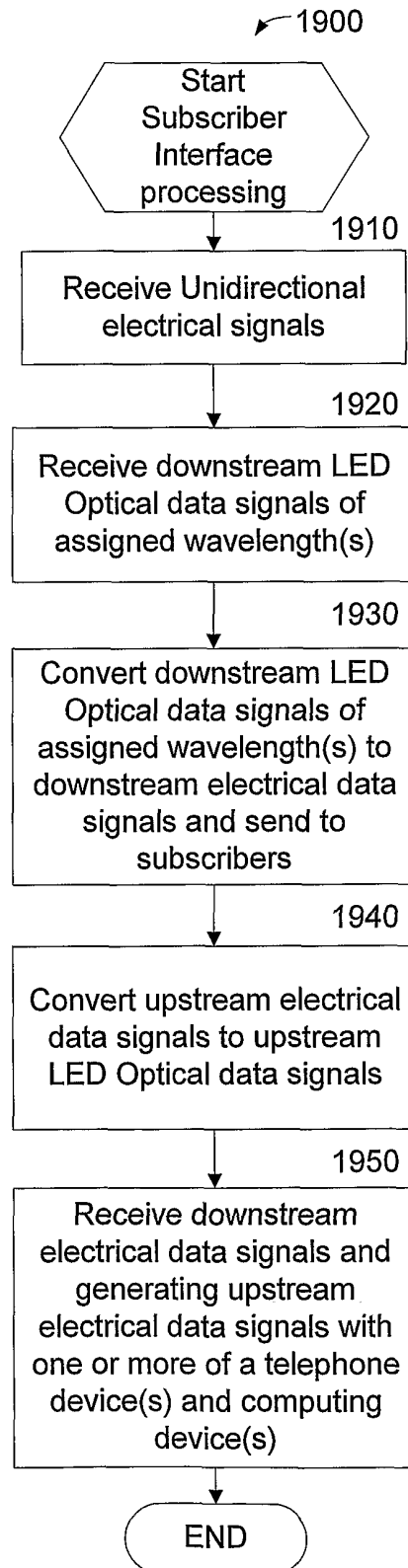

FIG. 19