

12

EUROPEAN PATENT SPECIFICATION

45 Date of publication of patent specification: **25.10.89**

51 Int. Cl.⁴: **D 03 D 39/02, D 04 B 35/22,**
D 03 J 1/00

21 Application number: **85102970.2**

22 Date of filing: **26.01.82**

60 Publication number of the earlier application in accordance with Art. 76 EPC: **0 058 478**

54 **Production of patterned fabrics.**

30 Priority: **05.02.81 GB 8103564**

43 Date of publication of application:
11.09.85 Bulletin 85/37

45 Publication of the grant of the patent:
25.10.89 Bulletin 89/43

84 Designated Contracting States:
BE DE GB NL

58 References cited:
FR-A-2 106 615
FR-A-2 271 158
FR-A-2 339 012
GB-A-1 421 621
US-A-4 244 309

70 Proprietor: **BRINTONS LIMITED**
Exchange Street P.O. Box 16
Kidderminster Worcestershire DY10 1AG (GB)

72 Inventor: **Lowe, Harry Frederick**
Ridge End Lea Bank Bewdley Road
Kidderminster Worcestershire (GB)
Inventor: **Brinton, Charls Topham Cecil**
Broncroft Castle
Craven Arms Shorpsire, SY7 0B1 (GB)
Inventor: **Pilling, John Reginald**
Redmarley
Great Witley Worcestershire (GB)
Inventor: **Jowett, John Bernard**
8 Woodlands Road Cookley
Near Kidderminster Worcestershire (GB)

7A Representative: **Rackham, Stephen Neil et al**
GILL JENNINGS & EVERY 53-64 Chancery Lane
London WC2A 1HN (GB)

Note: Within nine months from the publication of the mention of the grant of the European patent, any person may give notice to the European Patent Office of opposition to the European patent granted. Notice of opposition shall be filed in a written reasoned statement. It shall not be deemed to have been filed until the opposition fee has been paid. (Art. 99(1) European patent convention).

Description

This invention relates to the supplying of yarn to a container, for example in the production of patterned fabrics and is concerned with the problems which arise as a result of the different usage rates of the yarns of different colours. Such a method is described in GB—A—1 421 621. These problems are associated with a wide variety of different production processes such as knitting, embroidery, lace-making, carpet making and so forth. The basic difficulty stems from the fact that at the end of a production run the quantity of yarn remaining in the creel will differ widely from colour to colour and in the majority of cases, this residual yarn will represent a source of waste which cannot normally be avoided.

The co-pending application EP—A—58 478 from which the present application is divided, provides a solution to this problem by a method in which the pattern is analysed to determine the length of yarn required for each position in the pattern in order to produce a predetermined length of fabric and the required lengths of yarn are supplied to the positions in a creel, corresponding to the respective positions in the pattern. As a consequence, when the production run is complete, no yarn at all should, in theory, be left in the creel; in practice it is desirable to supply each position in the creel with a very slight excess of yarn above the calculated length and it is this excess which will remain in the creel.

It is, of course, necessary to prepare a creel in advance in accordance with the particular pattern to be produced and this primarily involves supplying the correct lengths of yarn of the correct colours to the respective positions in the creel, at least most of which may conveniently be defined by individual containers.

According to the present invention, this is achieved by feeding each individual yarn between a pair of metering rollers followed by an air jet through which the yarn passes and which blows the yarn into the container and compacts it, the metering rollers being controlled to stop the feeding action when the required length of yarn has been supplied.

It is found possible to increase the degree of compaction if the air pressure is increased periodically for short lengths of time, to produce pulses of higher pressure. The air flowing into each container needs to escape and to facilitate this, each container is preferably formed with air outlet openings.

The degree of compaction which is obtainable by air pressure is considerably less than the maximum which can be applied without introducing the risk of tangling. Accordingly, if the overall size of the individual containers represents a major factor in the operation of the creel, a stage of mechanical compression may be introduced after the feeding of the yarn is complete. This is most conveniently achieved by initially feeding the yarn to a first parallel-sided container which may be large enough to hold the required length

of yarn when compacted only by air pressure. After filling, the yarn is compacted by mechanical pressure which forces it through the bottom of the container and into a second smaller container of similar cross section arranged below the first container. The second container can thus be of a height which is less than that of the first by a factor depending on the degree of compression. It is found in practice that the yarn can be compressed to about one third of its original volume and the height of the second container can therefore be correspondingly reduced.

In order to accommodate particularly large quantities of yarn it may be allowed to pass through the bottom of the first container and into the second container before the application of mechanical pressure. Thus when the first container is nearly full of yarn compacted merely by air pressure, the bottom of the container may be opened to allow the yarn to pass into the second container without interrupting the feeding of the yarn. When the feeding of the yarn is complete the yarn may then be mechanically compacted in the normal way.

In order to expedite the filling of the large number of containers in a creel, a number of filling heads, each comprising a pair of metering rollers and an air jet may be arranged in a row and operated simultaneously to supply yarn to a corresponding number of containers in one row of a group, the row of filling heads and the group of containers being indexed in relation to one another after the filling of each number of containers in a row in order to fill a corresponding number of containers in a subsequent row. Since the containers in a row may be spaced more closely than the filling heads, the latter may be spaced so as to fill alternate containers in a row, the group of containers being indexed in relation to the filling heads which are stationary by a distance equal to the pitch of the rows and, when alternate containers in all the rows have been filled, the group of containers is indexed laterally by a distance equal to the pitch of the containers in the rows and the sequence is repeated to fill all the remaining containers.

Apparatus for supplying a predetermined length of yarn to a container in accordance with the invention comprises a pair of metering and feed rollers followed by an air jet injector for the yarn mounted above a support for the container, the rollers being controlled to stop their feeding action when the predetermined length of yarn has been injected into the container. Preferably the apparatus also includes means for mechanically compacting the yarn in the form of a ram with a central opening for the passage of the length of yarn which is in the process of being fed, so that the yarn is not broken by the descent of the ram. In order to allow the bottom of the first container to open, it preferably comprises a pair of hinged gates having operating mechanism for opening the gates in synchronism with the descent of the ram. The yarn may then be broken by the subsequent indexing movement by the inclusion of a

gripper for holding the yarn extending from the top of each container in the creel after filling. A member for pressing each broken yarn end into a slot at the top of the respective container may also be provided.

The invention will now be described in more detail, by way of example, with reference to the accompanying drawings, in which:-

Figure 1 is a diagrammatic view of an Axminster carpet loom showing the general arrangement of the associated yarn supply creel;

Figure 2 is an elevation of apparatus for supplying yarn to groups of containers making up the creel of Figure 1;

Figure 3 is an end view of the apparatus of Figure 2 seen from the left in that Figure;

Figure 4 is a sectional view to an enlarged scale of the upper part of the apparatus in Figure 2;

Figure 5 is a sectional view also to an enlarged scale of the lower part of the apparatus seen in Figure 2;

Figure 6 is a view similar to Figure 5 but showing a later stage in the operation;

Figure 7 is a plan view of a gripper mechanism seen in elevation in Figures 5 and 6;

Figure 8 is a view from the left hand side of the lower part of the apparatus seen in Figures 5 and 6, but with bottom gates in an open position;

Figure 9 is a plan view to an enlarged scale seen along the line IX—IX in Figure 4;

Figure 10 is a vertical section seen along the line X—X in Figure 9;

Figure 11 is a vertical section seen along the line XI—XI in Figure 9;

Figure 12 is a sectional plan view on the line XII—XII in Figure 11;

Figure 13 is a view to an enlarged scale of indexing mechanism forming the lower part of Figure 2;

Figure 14 is an enlarged sectional view of the bottom left hand corner of Figure 13;

Figure 15 is a sectional view seen from the left hand side of Figure 14;

Figure 16 is a view to an enlarged scale of cross-indexing apparatus forming part of the arrangement seen in Figure 13; and

Figure 17 is a plan view corresponding to Figure 16.

Turning first to Figure 1, a gripper Axminster carpet loom shown diagrammatically as 10 has a creel which is arranged in two levels, a floor level 11 and an upper level 12 mounted on a platform 13 extending above the loom. The tuft yarns held by the creel, instead of being wound in packages in the usual way, are held in vertical tubular containers arranged in rectangular groups each mounted in a wheeled trolley 15. The individual yarns extend upwardly from each trolley, being illustrated only in connection with the trolley identified specifically as 15A where they are indicated generally as 16. Each yarn passes upwardly into its own individual tube, groups of which extend downwardly to the loom 10 at 17. Similar tubes extend upwardly from above each trolley 15 as indicated diagrammatically at 18, and

since there may be several rows of trolleys in the creel, very large numbers of tubes are involved. In a typical example, each trolley may include eighteen rows each of sixteen containers, giving a total of two hundred and eighty-eight yarns per trolley. For a particular pattern of carpet, there may be as many as thirty-two trolleys arranged in four rows of eight. When the creel is initially set up, the individual yarns have to be threaded along their respective tubes to the loom, but when the creel is periodically replenished, lengths of yarn can be left in the tubes 18 so that the leading ends of the fresh lengths of yarn merely need to be knotted to the trailing ends of the lengths of yarn remaining in the tubes so that they can be pulled through the tubes and pieced up in the loom.

Each individual yarn container supplies yarn to a respective point in the pattern to be woven and thus, in the case of a gripper Axminster loom, as illustrated, each individual yarn is supplied to a respective yarn carrier. As previously described, the length of yarn in each container is carefully controlled to correspond to that required for the respective position in the pattern and the remainder of the description is concerned with the apparatus used for supplying each container of a group mounted in a trolley with the appropriate length of yarn. Although the description of Figure 1 has been related specifically to a gripper Axminster carpet loom, it will be understood that similar principles apply to the production of other types of patterned fabric where individual yarn supplies are directed to respective points in the pattern. Although Figure 1 illustrates all the yarns as being held in containers, it is quite possible that at least a small proportion of the yarns, particularly where relatively large quantities are required, should be wound on packages in the usual way, but this is not illustrated in the drawings.

Turning now to the feeding of the calculated lengths of yarn of the different colours to the individual containers of a group. Figure 2 shows the general arrangement of apparatus for this purpose. As already mentioned, a typical arrangement of containers in a trolley 15 comprises eighteen rows, each of sixteen containers. As an indication of typical dimensions, each container may be 85 mm square and 1200 mm long with a wall thickness of 1.5 mm. Although it is possible to fill all sixteen containers in a row simultaneously, the apparatus seen in Figures 2 and 3 includes only eight filler heads, each indicated generally as 20 and only one of which is seen in Figure 2. As can be seen from Figure 3, the filler heads 20 are spaced so as to fill alternate containers 21 and in operation, a trolley 15 is indexed through the apparatus by means of mechanism to be described later so as to supply yarn to alternate containers in each of the eighteen rows (to quote the example referred to previously) and when this operation is complete, the trolley 15 is indexed laterally by a distance equal to the pitch of containers in the rows and the process is repeated so as to supply yarn to all the intervening containers.

The yarns supplied to the containers 21 are

drawn from packages, one of which is seen at 25, mounted on a frame 26. The yarn shown as 27 passes through guides 28 and 29 and thence to a pair of metering rollers 30 and 31 seen in more detail in the enlarged view of Figure 4. The lower roller 30 is made of steel and is positively driven while the roller 31 is rubber covered to avoid slip and is pressed against the roller 30 by an air cylinder 32 seen in Figure 2. The metering action is performed by the upper roller 31 which is controlled by a computer produced tape or other form of information store corresponding to the respective position in the pattern. When the required length of yarn has been delivered, the roller 31 is raised to stop the feed. If yarn is not required in any particular container, the respective roller 31 remains in the up position.

After passing between the rollers 30 and 31, the yarn 27 passes downwardly through an air injector jet indicated generally as 35 in Figure 4 and seen in more detail in Figure 10 which will be described later. The effect of the air jet is to maintain the downward movement of the yarn 27 and, more importantly, to supply compressed air to the interior of a first or upper container 40 to which the yarn is supplied so as to have a compacting effect on the yarn as it accumulates towards the bottom of the container. There are, of course, as many upper containers 40 as there are filler heads 20, that is to say eight in the present example, as can be seen from Figure 3. The yarn accumulates in random fashion at the bottom of each container 40 and the compacting effect of the compressed air from the jet 35 is augmented by periodic pulses of higher pressure air. The pressure at the jet may be normally between twenty and thirty pounds per square inch (137—206 kN/m²) but this is increased to a pressure of eighty pounds per square inch (551 kN/m²) for example at intervals of about two seconds. This sudden increase in pressure has the effect of acting on the top of the packed yarn and compacting the body of the yarn beneath. Although not illustrated, the pulses of increased pressure may conveniently be obtained by charging an air reservoir at the increased pressure referred to and then abruptly discharging the air by way of a valve into the main airstream of the jet.

The amount of yarn fed into each upper container 40 is controlled individually as described above, but in general (with an exception to be mentioned later) does not fill the container above a point just below the ram 42 seen in Figure 4 which is formed with a central opening 43 for the passage of the yarn. The ram 42 is carried by four vertical rods 44 passing through seals 45 in the top 46 of the container 40, as seen in Figure 11 and described in more detail later. The upper ends of the rods 44 are fixed to a crosshead 50 which slides vertically on a guide rod 51 extending downwardly from a support 52 and controlled by an air motor 53.

The air motor 53 runs on a vertical guide 54 extending between supports 55 and 56. Although

the type of air motor used is by no means critical, a suitable type of such motor is one available commercially under the name ROL—AIR MOTA sold by Kay Pneumatics Limited. This motor operates on a peristaltic principle which utilises a pair of nipping rollers indicated diagrammatically as 58 which co-operate with an air hose constituting the guide 54. Air pressure is supplied to opposite ends of the hose by way of lines 59 and 60 connected to a reversing valve. When air is supplied to the bottom of the hose 54 the pressure acting beneath the nip of the rollers 58 drives the motor 53 up wardly and the application of air pressure to the top of the hose drives the motor 53 downwardly. When the filling of the container 40 is complete, the ram 42 is brought into action and driven downwardly by the motor 53 to compact the yarn against the bottom of the container 40.

As seen in Figures 5 and 6, the bottom of each upper container 40 is constituted by a pair of gates 61 each extending from a bush 62 turning about an axle 63, the angular position of which is controlled by an arm 64, the other end of which is connected to the piston rod 65 of an air cylinder 66. In the full line position of the gates 61, they resist the downward pressure exerted by the ram 42 so that the yarn is compacted as previously described. In the position shown in Figure 5, the ram 42 has just operated to force the compacted yarn into the container 21 and has returned to its uppermost position (not seen). The position of the ram illustrated in Figure 6 corresponds to the maximum compaction of the quantity of yarn which has been fed to the upper container 40 and at this point, the air cylinders 66 are operated to swing the gates 61 downwardly into the vertical positions shown in dotted lines as 61'. This allows the compacted body of yarn to pass downwardly into the container 21 which is of the same cross section as the container 40 and is in register with it as a result of indexing movement of the trolley 15 on which it is mounted.

The downward movement of the ram 42 then continues until all the compacted yarn has been forced into the container 21 except for a length of yarn which extends upwardly from the compacted mass, through the opening 43 into the ram 42 and back to the rollers 30 and 31. The ram 42 then returns upwardly to its initial position and the gates 61 return to the full-line, closed position of Figure 5 so as to clamp the length of yarn between them. The individual rams 42 operate independently of one another, their time of operation depending on the quantity of yarn to be transferred from an upper container 40 to a lower container 21. If no yarn at all is to be supplied to any particular container, the respective ram does not operate at all.

On the other hand, if any lower container 21 is required to accommodate a particularly large quantity of yarn, that is to say more than can be held by an upper container 40, a modified form of operation is necessary. As the yarn, compacted only by air pressure approaches the top of the

container 40, the gates 61 are opened without interrupting the feed of yarn. The yarn already in the container 40 is thus allowed to drop into the corresponding lower container 21, the movement being assisted by the air pressure. Since each container 40 is considerably longer than the respective lower container 21, the plug of yarn spans the gap between the two containers and filling of the upper container 40 proceeds as previously. When the full required amount of yarn has been delivered to the upper container 40, the ram 42 operates in the same manner as previously described, compressing the complete body of yarn and forcing it all into the lower container 21. The ram 42 then returns and the gates 61 close, as previously described.

The opening of the gates 61 is controlled on a time basis, i.e. by means of a signal from an electrical timer rather than in response to a signal that the correct amount of yarn has been supplied to the upper container. In practice, this timing corresponds to a point when the container 40 is approximately two-thirds full. As mentioned previously, feeding of the yarn continues without interruption and the final operation of the ram 42 to compress all the yarn into the lower container 21 takes place in exactly the same manner as previously described. This modified mode of operation represents the exception referred to above in which the total quantity of yarn supplied is greater than that which would normally fill a container 40 without mechanical compaction.

When all the rams have returned to their initial positions, the apparatus is ready for the indexing of the trolley which is represented by movement to the left as seen in Figures 5 and 6. Before this movement occurs, the containers 40 are raised slightly, e.g. by 25 mm, to provide working clearance with the tops of the containers 21. This upward movement is produced by an air cylinder 70 connected to one arm of a bell crank 71 pivoted to the frame at 72 and the other arm of which is connected to the assembly of containers 40, as seen in Figure 2.

The method of breaking the length of yarn extending from the gates 61 will now be described in more detail, with reference to Figures 5 to 7. As soon as the gates 61 have closed to clamp the yarn, the length of yarn extending between the gates and the top of the container 21 and indicated as 70 is engaged by a gripper mechanism indicated generally as 71 and seen in plan view in Figure 7 in relation to the container 21. The mechanism includes a fixed jaw 72 and a movable jaw 73 controlled by an air cylinder 74. Both jaws are supported by an L-beam 75 seen in dotted lines in Figure 7, which extends along the gripper mechanisms of all the containers 40. This in its turn is carried by an arm 78 pivoted at 79 and operated by a further air cylinder (not shown) so as to move from the position of Figure 5 to that of Figure 6. As a first stage in the operation, the jaw 73 is moved to the closed position to grip the yarn 70 and the mechanism 71 is then moved to the position of Figure 6 so as to break the yarn 70

between the gripper and the point where it is held by the gates 61. At the same time, the trolley 15 and hence the container 21 is indexed to the left as already described. As a consequence, the yarn below the gripper jaws 72, 73 is held above the left hand side of the container 21 which, as a result of the indexing movement is no longer beneath the corresponding container 40, the next container in the sequence having moved into this position.

While the yarn 70 is held in this position a pusher member 82 mounted for vertical movement in guides (not shown) as indicated by the double headed arrow in Figure 6 is controlled to move from an upper position shown in Figure 5 to a lower position shown in Figure 6 in which a forked end portion 83 engages the length of yarn 70 and presses it into a small notch in the top of the wall of the container 21. Each container has such a notch, as can be seen at 84 in Figures 5 and 6. This notch is sufficiently narrow to grip the yarn end and the pusher member 82 is then retracted to leave the yarn end held in position, after which it is released by opening of the jaws 72, 73 of the gripper mechanism 71. Each filled container 21 in the trolley 15 is thus left with a projecting yarn end held in the notch 84 and these ends are thus readily available for joining to the yarn ends projecting from the tubes 18 of the creel, as previously described. After joining, it is a simple matter to pull each yarn through its tube for piecing up in the respective yarn carrier of the loom.

Figure 8 shows further details of the gates 61 in the open position indicated as 61' in Figure 5. As shown, the gates are perforated to allow free passage of the air which is blown into each upper container 40 to compact the yarn against the gate 61 at the bottom of each container. The walls of the containers themselves are impervious and the air which flows downwardly through the compacted mass of yarn must therefore be able to escape freely through the gates 61.

Figures 9 to 12 shown constructional details of the air jet 35 and the ram 42 at the upper end of each upper container 40. The injector air jet 35 includes a central passage 86 for the passage of yarn which broadens out at 87, air being supplied to this broader part by an inclined passage 88 leading from an annular space 89. Air is supplied to the space 89 by a line 90 provided with a screw connection 91. The flow of air down the passage 88 assists the movement of the yarn through the passage 86 and the resultant air pressure within the container 40 compacts the yarn at the bottom.

The ram 42, as seen from Figures 9 and 12 is square in shape to match the shape of the cross section of the container 40 and has an appreciable clearance from the wall of the container to avoid the risk of compacted yarn becoming jammed. The central opening 43, however, is circular to avoid any corners which might trap the yarn.

The remaining Figures illustrate the mechanism for indexing trolleys beneath the filling arrangement already described. As seen in Figures 1 and

2, each trolley is provided with a swivel castor 95 at each corner and remains supported on these castors during the successive stages of filling and indexing. For purposes of accurate location and indexing, each trolley is connected to an indexing frame 100 by means of a pair of pegs 101 which are moved upwardly to engage corresponding holes close to the forward corners of each trolley, best seen in Figure 13. Each peg 101 is mounted for vertical movement in a corresponding socket in structure 102 mounted beneath the frame 100 and is controlled for movement in its socket by connection to an arm 103 fixed to a shaft 104 which extends across the width of the indexing frame 100 to control both pegs 101. The shaft 104 is rocked between its two positions by means of an arm 105 which is itself operated by an air cylinder 106. Once the trolley has been coupled to the frame 100 by means of the pegs 101, it accurately follows the movements of the frame both from left to right as seen in Figures 2 and also in a direction at right angles to this.

The frame 100 is supported at each side by rollers 110 running between lower and upper rails 111 and 112 fixed to the main frame of the apparatus. The frame is indexed from left to right as seen in Figures 2 and 13 by means of a drive chain 114 passing around sprockets 115 and 116. The sprockets 116 on each side are driven in steps by a chain drive 117 by means of an electric motor 118 operating through a clutch/brake unit 119 and a speed reducing gear box 120 to produce the necessary indexing motion from left to right. To ensure accurate indexing, the position of the trolley 15 in relation to the frame 100 is constantly monitored by a detector arm 140 which is pivoted to the frame 100 and biased against the front of the trolley. The upper end of the arm 140 carries a micro-switch 141 which controls the clutch/brake 119 and cooperates with a bar 142 formed with spaced projections 143. The pitch of the projections 143 is equal to the required indexing distance and each time the plunger of the micro-switch engages a projection 143, indexing movement is interrupted.

The first step of movement brings the first row of containers 21 in the trolley 15 into register beneath the filling containers 40 and each successive step of indexing brings the next row of containers 21 into this position. As described above, each step of indexing is associated with breakage of the yarns from the filled containers so that, after the last row of containers has been filled, one further step of indexing is required in order to break the yarns from the last row of containers.

As described previously, only alternate containers in a row are filled as a result of a single operation so that, after the trolley has completed one sequence of indexing, i.e. to fill alternate containers in all the rows, a second sequence is necessary in order to fill the intervening containers. The trolley is accordingly indexed in the reverse direction to bring it back to its starting position and is then cross-indexed by a distance

equal to the pitch of the containers in the rows so that the intervening, unfilled containers are brought into register beneath the upper filling containers 40.

The cross indexing mechanism is illustrated in Figure 16 and 17. As seen from Figure 16, the structure 102 defining the socket for reception of each peg 101 is mounted for horizontal sliding motion on a bar 121 extending between pairs of brackets 122 extending downwardly from the frame 100. The members 102 are inter-connected for this sliding movement by a bar 124 which slides through the brackets 122 and has a projecting portion 125 to which is pivoted a connecting rod 126 driven by an eccentric 127. The eccentric 127 forms part of a gear wheel 128 meshing with a smaller pinion 129 which, in its turn, is driven by an electric motor 130 by way of a clutch/brake unit 131 and a speed reducing gear box 132. An angular displacement of the eccentric 127 through approximately one quarter of a revolution in an anti-clockwise direction moves the connecting rod 126 to the position shown in dotted lines as 126', thus moving the bar 124 a corresponding distance to the right. This moves the parts 102 also to the right to the position shown in dotted lines at 102' and hence indexes the trolley as a whole by a corresponding distance to the right on its swivel castors 95. The filling sequence is then repeated to fill all the remaining containers and to break all the yarns, after which the trolley is again reverse-indexed and finally removed from the machine in readiness for transfer to the creel.

Claims

1. A method of supplying yarn to a container characterised in that the yarn is fed between a pair of metering rollers followed by an air jet through which the yarn passes and which blows the yarn into the container and compacts it, the metering rollers being controlled to stop the feeding action when the required length of yarn has been supplied.

2. A method according to claim 1 in which the air pressure is increased periodically for short lengths of time, to produce pulses of higher pressure to assist compaction of the yarn.

3. A method according to claim 1 or claim 2 for supplying yarn to a container in the form of a cell of uniform cross section and having a vertical dimension at least several times as great as its horizontal dimensions, in which the yarn in the container is subsequently compacted mechanically.

4. A method according to claim 3 in which the yarn is fed initially to a first, parallel-sided container and is then compacted by mechanical pressure which forces it through the bottom of the container and into a second smaller container of similar cross section arranged below the first container.

5. A method according to claim 4 in which the yarn compacted by air pressure is allowed to pass

through the bottom of the first container and into the second before the application of mechanical pressure.

6. A method according to any one of the preceding claims for supplying yarn to a group of containers for a creel in the form of a rectangular array, consisting of a predetermined number of rows with a predetermined number of containers in each row, in which a number of filling heads, each comprising a pair of metering rollers and an air jet are arranged in a row and are operated simultaneously to supply yarn to a corresponding number of containers in a row, the row of filling heads and the group of containers being indexed in relation to one another after the filling of each number of containers in a row in order to fill a corresponding number of containers in a subsequent row.

7. A method according to claim 6, in which the filling heads are spaced so as to fill alternate containers in a row and the group of containers is indexed in relation to the filling heads which are stationary, by a distance equal to the pitch of the rows and, when alternate containers in all the rows have been filled, the group of containers is indexed laterally by a distance equal to the pitch of the containers in the rows and the sequence is repeated to fill all the remaining containers.

8. A method according to claim 4 alone or together with any one of claims 5 to 7, in which on the completion of the filling of the or each second container, the yarn extending from the top of this container is held by a gripper at one point and clamped at an adjacent point at the base of the first or filling container and the yarn between the two points is broken as a result of movement of the gripper, the broken end extending from the filled container being held in readiness for knotting to a further length of yarn.

9. Apparatus for supplying a predetermined length of yarn (27) to a container (40) for a creel by a method according to claim 1, comprising a pair of metering and feed rollers (30, 31) followed by an air jet injector (35) for the yarn mounted above a support for the container, the rollers being controlled to stop their feeding action when the predetermined length of yarn has been injected into the container.

10. Apparatus according to claim 9 and including a mechanical ram (42) for increasing the compaction of the yarn and having a central opening (43) for the passage of the length of yarn which is in the process of being fed 11. Apparatus according to claim 10 and including a first container (40) of uniform cross section mounted in fixed relation to the ram (42) and having a bottom capable of being opened to allow the ram to force yarn out of the first container and into a second container (21) of similar cross section arranged below the first.

12. Apparatus according to claim 11 in which the bottom of the first container comprises a pair of hinged gates (61, 61') having operating mechanism (70, 71) for opening the gates to allow yarn to pass from the first container into the second.

13. Apparatus according to any one of claims 9 to 12 for supplying predetermined lengths of yarn to a group of containers for a creel in the form of a rectangular array, consisting of a predetermined number of rows with a predetermined number of containers (40) in each row, the apparatus comprising a row of filler heads (20) each having a pair of metering rollers (30, 31) and an air jet injector (35) arranged at a spacing dependent on that of the containers in the group and mechanism (114—116) for indexing the group of containers in relation to the row of filler heads.

14. Apparatus according to claim 13 including a trolley (15) for the containers of the group and in which the indexing mechanism operates to move the trolley step-by-step in relation to the row of filler heads (20).

15. Apparatus according to claim 14 in which the filler heads (20) are spaced apart at double the pitch of the containers (40) in corresponding rows and the indexing mechanism also operates to move the trolley laterally by a distance equal to the pitch of the containers in the rows.

16. Apparatus according to claim 11 and any one of claims 13 to 15 and including mechanism for producing relative movement in a vertical direction between the first containers (40) and the second containers (21) so as to increase the separation between them during the indexing movement.

17. Apparatus according to claim 12 and any one of claims 13 to 16 in which each pair of gates (61, 61') operates to clamp the yarn between them and a movable gripper (71) is provided for holding the yarn extending from each pair of gates after filling, whereby movement of the respective gripper serves to break each yarn between the gates and the gripper.

18. Apparatus according to claim 17 and including a member (82) for pressing each broken yarn end into a slot (84) at the top of the respective second container.

Patentansprüche

1. Verfahren zum Liefern von Garn zu einem Behälter, dadurch gekennzeichnet, daß das Garn zwischen einem Meßrollenpaar gefolgt von einer Luftdüse, durch die das Garn hindurchtritt und die das Garn in den Behälter bläst und es verdichtet, zugeführt wird, und daß die Meßrollen gesteuert werden, um die Zuführung zu unterbrechen, wenn die benötigte Garnlänge geliefert worden ist.

2. Verfahren nach Anspruch 1, bei dem der Luftdruck periodisch für kurze Zeitspannen gesteigert wird, um Impulse mit höherem Druck zu erzeugen, um eine Verdichtung des Garns zu unterstützen.

3. Verfahren nach Anspruch 1 oder 2 zum Liefern von Garn zu einem Behälter in Form einer Zelle mit einheitlichem Querschnitt, dessen vertikale Abmessung mindestens mehrfach so groß ist wie seine horizontalen Abmessungen, bei dem das Garn im Container anschließend mechanisch verdichtet wird.

4. Verfahren nach Anspruch 3, bei dem das Garn anfänglich einem ersten, parallelseitigem Behälter zugeführt und danach durch mechanischen Druck verdichtet wird, der es durch den Behälterboden und in einen zweiten kleineren Behälter mit gleichem Querschnitt hindurchdrückt, der unter dem ersten Behälter angeordnet ist.

5. Verfahren nach Anspruch 4, bei dem das durch Luftdruck verdichtete Garn durch den Boden des ersten Behälters hindurchtreten und vor der Anwendung mechanischen Drucks in den zweiten Behälter gelangen kann.

6. Verfahren nach irgendeinem der vorstehenden Ansprüche zum Zuliefern von Garn zu einer Gruppe von Behältern für ein Spulengestell in Form einer rechteckigen Anordnung, umfassend eine vorbestimmte Reihenanzahl mit einer vorbestimmten Anzahl von Behältern in jeder Reihe, in der eine Anzahl von Schußköpfen, die jeweils ein Meßrollenpaar und eine Luftdüse umfassen, in einer Reihe angeordnet sind, und gleichzeitig betätigt werden, um Garn zu einer entsprechenden Anzahl von Behältern in einer Reihe zu liefern, wobei die Reihe der Schußköpfe und die Behältergruppe in Beziehung zueinander, nachdem jede Behälteranzahl in der Reihe gefüllt ist, weitergeschaltet bzw. indexiert werden, um eine entsprechende Behälteranzahl in der nachfolgenden Reihe zu füllen.

7. Verfahren nach Anspruch 6, bei dem die Schußköpfe derart beabstandet sind, daß sie alternierende Behälter in einer Reihe füllen, und wobei die Behältergruppe in Beziehung zu den Schußköpfen, die stationär sind, geschaltet wird, durch eine Entfernung, die der Steigung der Reihen gleicht und, wenn die alternierenden Behälter in allen Reihen gefüllt worden sind, wird die Behältergruppe seitlich weiter geschaltet durch eine Entfernung, die der Steigung der Behälter in den Reihen gleicht, und wobei die Folge wiederholt wird, um alle übrigen Behälter zu füllen.

8. Verfahren nach Anspruch 4 allein oder zusammen mit irgendeinem der Ansprüche 5 bis 7, bei dem bei der Vervollständigung des Füllens des oder jedes zweiten Behälters das sich von der Spitze dieses Behälters erstreckende Garn durch einen Greifer an einem Punkt gehalten und an einem benachbarten Punkt am Boden des ersten oder Füllcontainers angeklemt wird, und daß das Garn zwischen den zwei Punkten als Ergebnis der Bewegung des Greifers durchgerissen wird, wobei sich das abgerissene Ende vom gefüllten Behälter, der für die Knüpfarbeit bereitgehalten wird, bis zu einer weiteren Garnlänge erstreckt.

9. Vorrichtung zum Liefern einer vorbestimmten Länge an Garn (27) zu einem Behälter (40) für ein Spulengestell gemäß einem Verfahren nach Anspruch 1, umfassend ein Paar an Meß- und Zuführrollen (30, 31), gefolgt von einem Luftdüseninjektor (35) für das Garn, der über einer Halterung für den Behälter befestigt ist, wobei die Rollen gesteuert werden, um ihre Zuführungssaktion anzuhalten, wenn die vorbestimmte Garnlänge in den Behälter eingeschossen worden ist.

10. Vorrichtung nach Anspruch 9 und einschließlich einer mechanischen Ramme (42), um die Verdichtung des Garns zu steigern, mit einer zentralen Öffnung (43) zu Durchtritt der Garnlänge, die gerade zugeführt wird.

11. Vorrichtung nach Anspruch 10 und einschließlich einen ersten Behälter (40) mit einheitlichem Querschnitt, der in fester Beziehung zur Ramme (42) befestigt ist und einen Boden besitzt, der geöffnet werden kann, damit die Ramme das Garn aus dem ersten Behälter drücken und in den zweiten Behälter (21) mit gleichem Querschnitt hineindrücken kann, der unter dem ersten angeordnet ist.

12. Vorrichtung nach Anspruch 11, bei der der Boden des ersten Behälters ein Paar schwenkbarer Tore (61, 61') umfaßt, die einen Betriebsmechanismus (70, 71) zum Öffnen der Tore besitzen, damit Garn vom ersten in den zweiten Behälter passieren kann.

13. Vorrichtung nach irgendeinem der Ansprüche 9 bis 12 zum Liefern vorbestimmter Garnlängen zu einer Behältergruppe für ein Spulengestell in Form einer rechteckigen Anordnung, umfassend eine vorbestimmte Anzahl an Reihen mit einer vorbestimmten Anzahl an Behältern (40) in jeder Reihe, wobei die Vorrichtung eine Reihe von Schußköpfen (20) umfaßt, die jeweils ein Paar an Meßrollen (30, 31) und einen Luftdüseninjektor (35) umfassen, die beabstandet in Abhängigkeit von den Behältern in der Gruppe angeordnet sind, und wobei ein Mechanismus (114 bis 116) zum weiterschalten bzw. indexieren der Gruppe an Behältern in Beziehung zur Reihe der Schußköpfe vorgesehen ist.

14. Vorrichtung nach Anspruch 13, einschließlich eines Förderwagens (15) für die Behälter der Gruppe, und bei der der Indexierungsmechanismus betätigt wird, um den Förderwagen Schritt für Schritt in Beziehung zur Reihe der Schußköpfe (20) zu bewegen.

15. Vorrichtung nach Anspruch 14, bei der die Schußköpfe (20) in doppelter Steigung der Behälter (40) in entsprechenden Reihen beabstandet sind, und daß der Indexierungsmechanismus ebenfalls betätigt wird, um den Förderwagen seitlich zu bewegen in einer Entfernung, die der Steigung der Behälter in den Reihen entspricht.

16. Vorrichtung nach Anspruch 11 und irgendeinem der Ansprüche 13 bis 15, und einschließlich eines Mechanismus zum Erzeugen von Relativbewegung in einer senkrechten Richtung zwischen den ersten Behältern (40) und den zweiten Behältern (21), um die Trennung zwischen ihnen während der Indexierungsbewegung zu erhöhen.

17. Vorrichtung nach Anspruch 12 und irgendeinem der Ansprüche 13 bis 16, bei der jedes Paar der Tore (61, 61') derart betrieben wird, daß es das Garn zwischen ihnen einklemmt, und wobei ein bewegbarer Greifer (71) vorgesehen ist, um das sich von jedem Paar der Tore nach dem Eintragen erstreckende Garn zu halten, wobei die Bewegung des entsprechenden Greifers dazu dient, jedes Garn zwischen den Toren und dem Greifer zu zerreißen.

18. Vorrichtung nach Anspruch 17, und einschließlich ein Glied (82) zum Drücken jedes zerrissenen Garnendes in einen Schlitz (84) an der Spitze des entsprechenden zweiten Behälters.

Revendications

1. Méthode d'alimentation d'un conteneur en fil, caractérisée par le fait que le fil avance entre deux rouleaux de mesure suivis d'un jet d'air devant être traversé par le fil qui est ainsi introduit par soufflage et comprimé dans le conteneur, les rouleaux de mesure étant contrôlés de manière à interrompre l'action d'alimentation lorsque la longueur de fil requise a été introduite.

2. Méthode selon la revendication 1, où la pression d'air est périodiquement augmentée pour de courtes durées afin de produire des impulsions de plus forte pression devant contribuer au compactage du fil.

3. Méthode selon la revendication 1 ou la revendication 2 d'alimentation en fil d'un conteneur en forme de cellule de coupe transversale uniforme dont la dimension verticale est au moins plusieurs fois multiple de la dimension horizontale et où le fil dans le conteneur est ensuite comprimé par moyen mécanique.

4. Méthode selon la revendication 3 où le fil est introduit tout d'abord dans un premier conteneur à parois parallèles puis est comprimé par pression mécanique qui l'enfoncé à travers le fond de ce conteneur et le fait déboucher dans un second conteneur plus petit de coupe transversale semblable placé sous le premier conteneur.

5. Méthode selon la revendication 4, où le fil comprimé par la pression d'air passe à travers le fond du premier conteneur et débouche dans le second avant qu'il y ait application de pression mécanique.

6. Méthode selon toute revendication précédente concernant l'alimentation en fil d'un groupe de conteneurs pour un cadre de disposition rectangulaire, composé d'un nombre prédéterminé de rangées comportant un nombre prédéterminé de conteneurs par rangée, où un certain nombre de têtes de charge, comportant chacune deux rouleaux de mesure et une buse de jet d'air, sont placées en rangée et fonctionnent simultanément pour fournir le fil à un nombre correspondant de conteneurs placés en rangée, la rangée de têtes de charge et le groupe de conteneurs étant indexés les uns par rapport aux autres apers la charge de chaque groupe de conteneurs dans une rangée donnée afin d'assurer la charge d'un nombre correspondant de conteneurs dans une rangée suivante.

7. Méthode selon la revendication 6, où les têtes de charge sont espacées de sorte à remplir des conteneurs alternés dans une rangée donnée et où le groupe de conteneurs est indexé par rapport aux têtes de charge qui sont stationnaires, selon une distance égale à l'écartement entre les rangées et, lorsque les conteneurs alternés de toutes les rangées sont remplis, le groupe de conteneurs est indexé dans le sens latérale selon une dis-

tance égale à l'écartement entre les conteneurs dans les rangées, cette séquence étant répétée pour remplir tous les conteneurs restant.

8. Méthode selon la revendication 4 uniquement ou conjointement avec l'une des revendications 5 à 7, où à la fin de la charge du second conteneur ou de chaque second conteneur, le fil sortant du haut de ce conteneur est tenu fermement par une pince en un point et serré en un point proché de la base du premier conteneur ou conteneur de charge et ce fil est cassé entre ces deux points du fait du mouvement de la pince, l'extrémité rompue sortant du conteneur rempli étant maintenue prête pour être nouée sur une autre longueur de fil.

9. Appareil d'alimentation d'une longueur de fil prédéterminée (27) dans un conteneur (40) pour un cadre conformément à une méthode selon la revendication 1, comprenant deux rouleaux d'alimentation et de mesure (30, 31) suivis d'un injecteur de jet d'air (35) sur le fil monté au-dessus d'un support du conteneur, les rouleaux étant contrôlés pour interrompre l'avance du fil lorsque la longueur prédéterminée a été injectée dans le conteneur.

10. Appareil selon la revendication 9 et comportant un marteau mécanique (42) visant à augmenter le compactage du fil et présentant une ouverture centrale (43) laissant passer la longueur de fil en cours d'alimentation.

11. Appareil selon la revendication 10 et comportant un premier conteneur (40) de coupe transversale uniforme monté en une position fixe par rapport au marteau (42) et comportant un fond ouvrable destiné à laisser le marteau enfoncer le fil hors du premier conteneur et dans un second conteneur (21) de coupe transversale semblable placée sous le premier.

12. Appareil selon la revendication 11, où le fond du premier conteneur comporte deux battants articulés (61, 61') dont les mécanismes de commande (70, 71) permettent d'ouvrir les battants pour laisser passer le fil du premier conteneur au second.

13. Appareil selon toute revendication 9 à 12 d'alimentation de longueurs prédéterminées de fil dans un groupe de conteneurs pour un cadre de disposition rectangulaire, composée d'un nombre prédéterminé de rangées comportant un nombre prédéterminé de conteneurs (40) par rangée. L'appareil est composé d'une rangée de têtes de charge (20) comportant chacune deux rouleaux de mesure (30, 31) et une buse d'injection d'air (35) disposés à une distance correspondant à celle existant entre les conteneurs du groupe et comportant un mécanisme d'indexage (114, 116) du groupe de conteneurs par rapport à la rangée des têtes de charge.

14. Appareil selon la revendication 13 comportant un chariot (15) de transport des conteneurs du groupe, où le mécanisme d'indexage fonctionne pour faire avancer le chariot pas-à-pas par rapport à la rangée de têtes de charge (20).

15. Appareil selon la revendication 14, où les têtes de charge (20) sont espacées selon une

distance double de l'écartement entre les conteneurs (40) dans les rangées correspondantes et où le mécanisme d'indexage fonctionne également pour avancer le chariot dans un sens latéral selon une distance égale à l'écartement entre les conteneurs des rangées.

16. Appareil selon la revendication 11 et toute revendication 13 à 15, comportant un mécanisme de déplacement relatif dans un sens vertical entre les premiers conteneurs (40) et les seconds conteneurs (21), afin d'augmenter la séparation entre ceux-ci durant le mouvement d'indexage.

17. Appareil selon la revendication 12 et toute

revendication 13 à 16, où chaque paire de battants (61, 61') fonctionne pour agripper le fil tandis qu'une pince mobile (71) maintient le fil en place à la sortie de chaque paire de battants après la charge, tout mouvement de la pince correspondante permettant de couper le fil entre les battants et la pince.

18. Appareil selon la revendication 17 et comportant un mandrin (82) destiné à comprimer chaque extrémité du fil cassé dans une fente (84) pratiquée dans le haut du second conteneur correspondant.

5

10

15

20

25

30

35

40

45

50

55

60

65

10

Fig. 1.

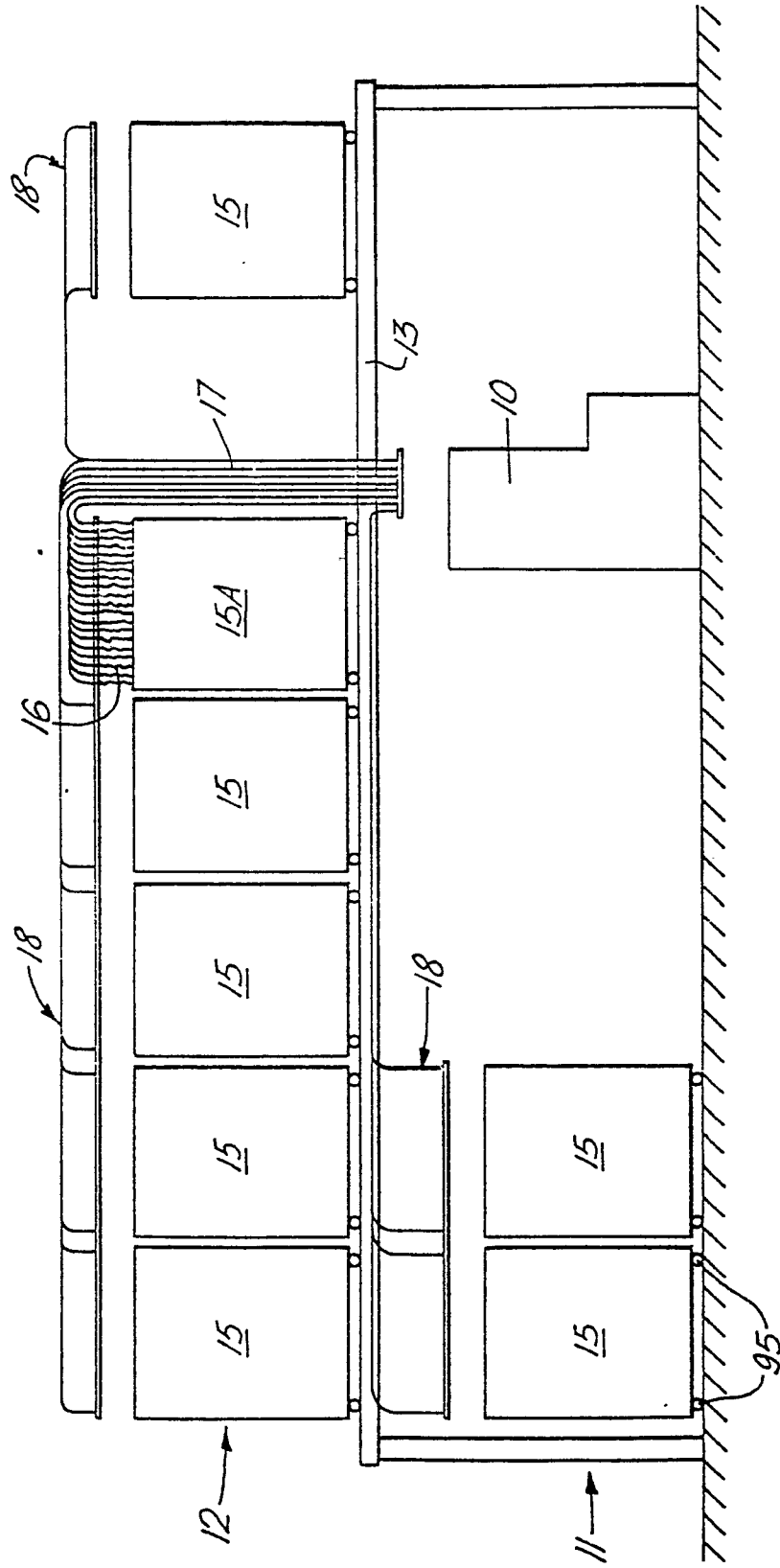

Fig. 2.

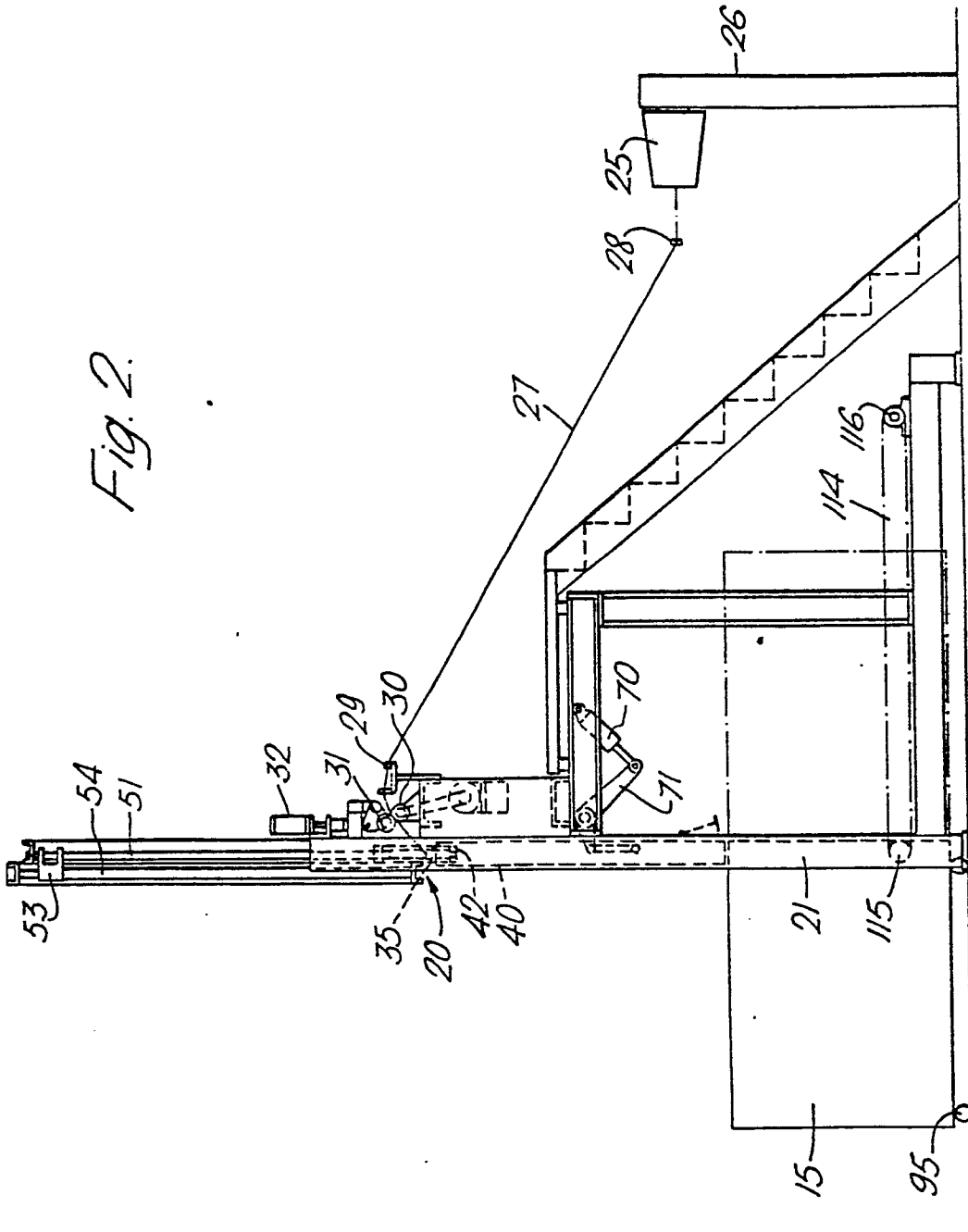

Fig. 3.

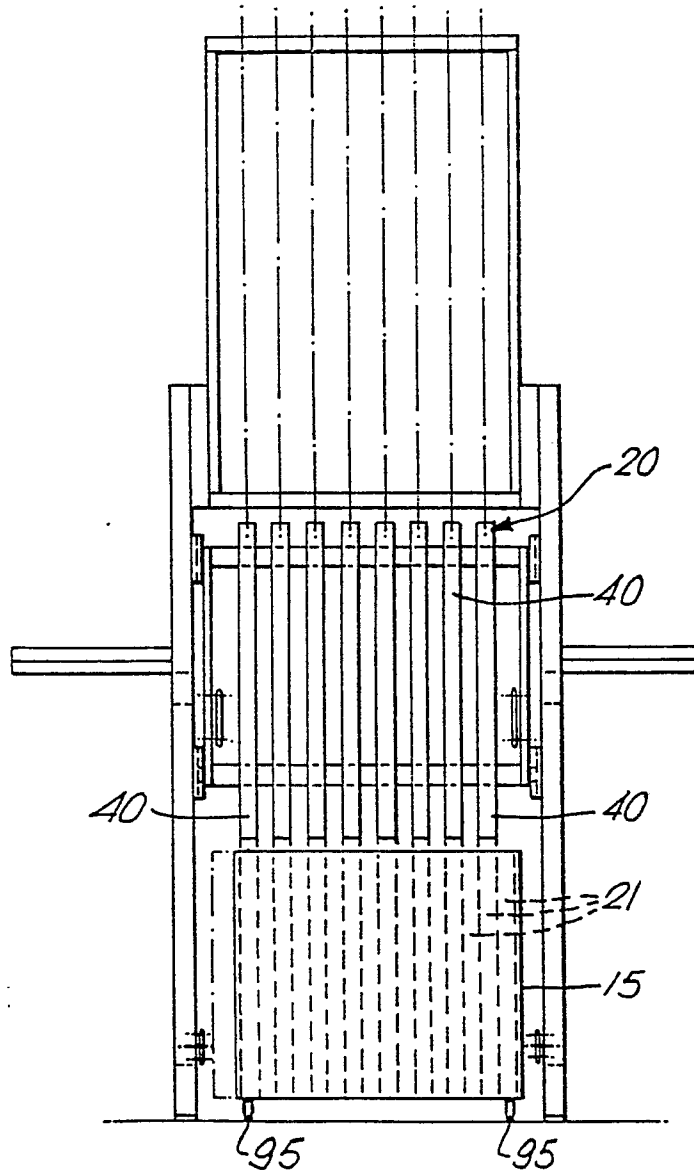
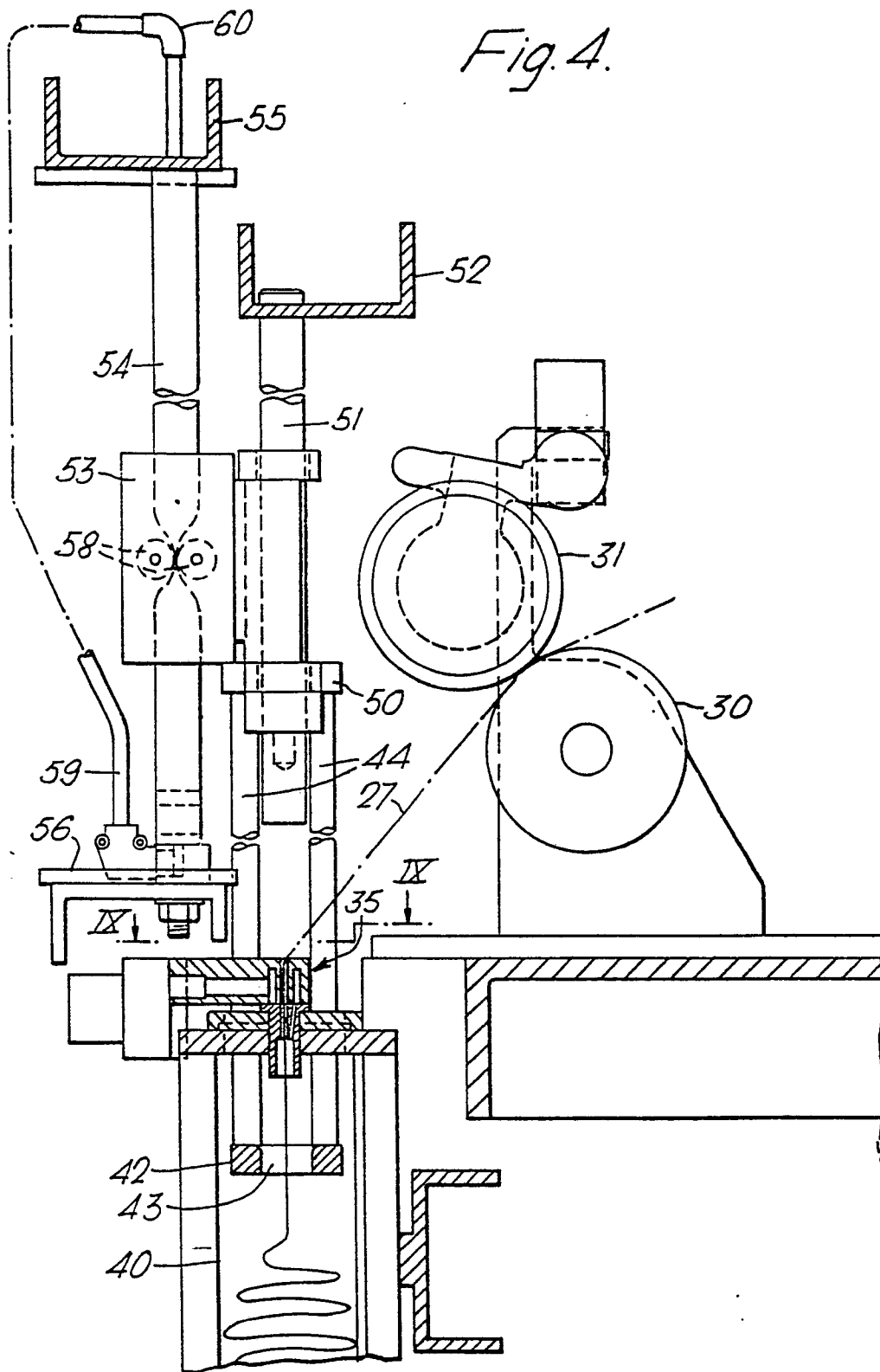

Fig. 4.



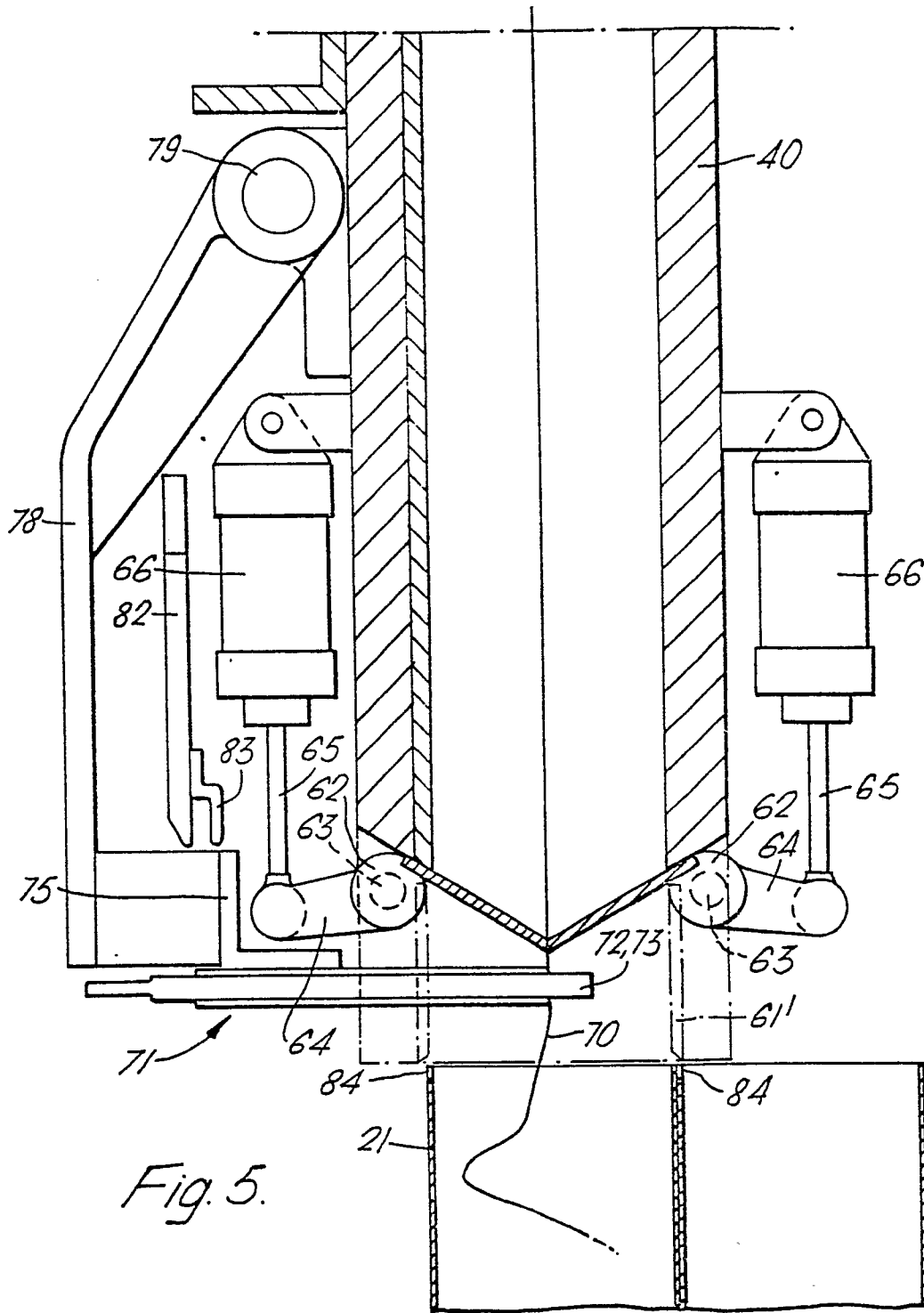
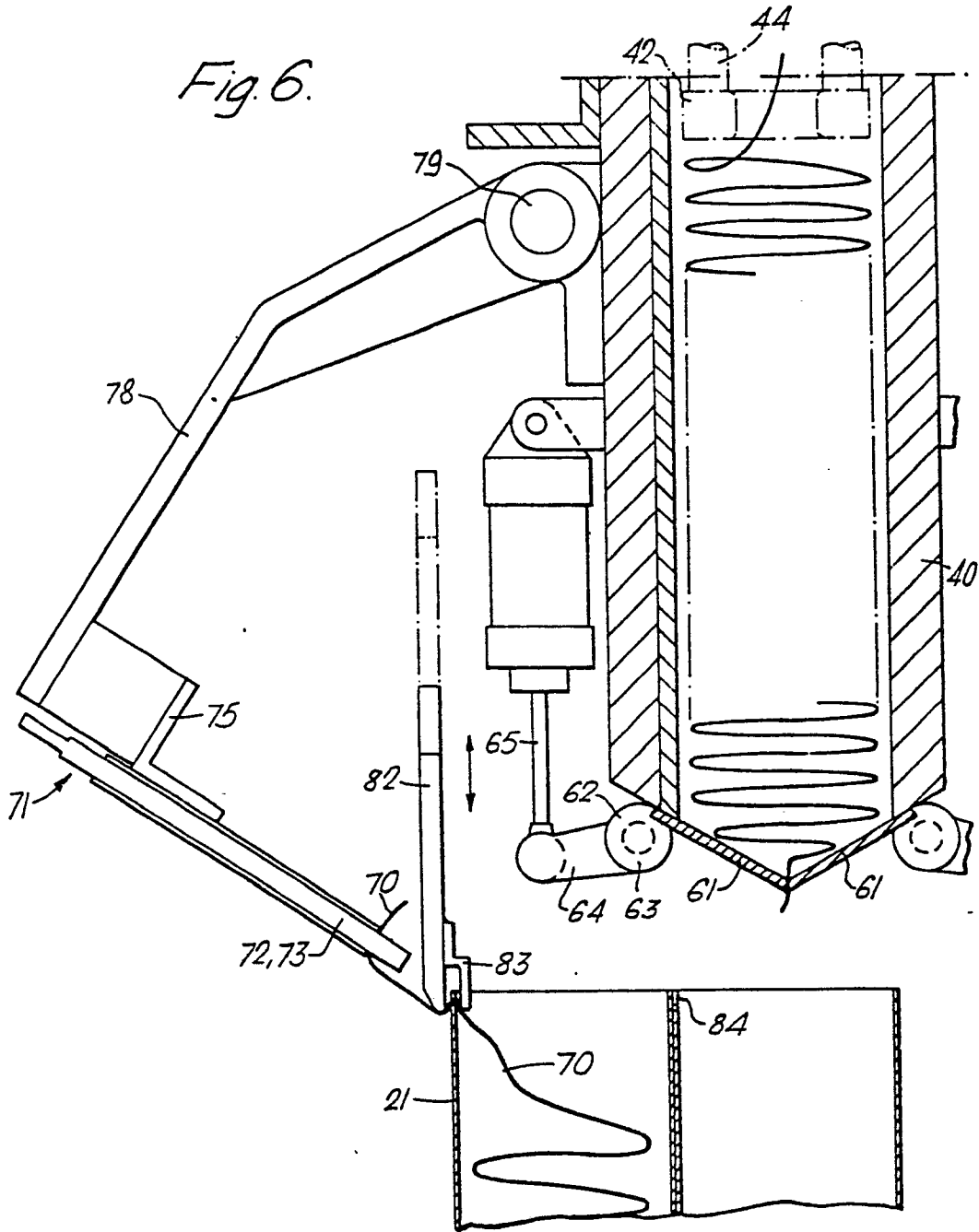
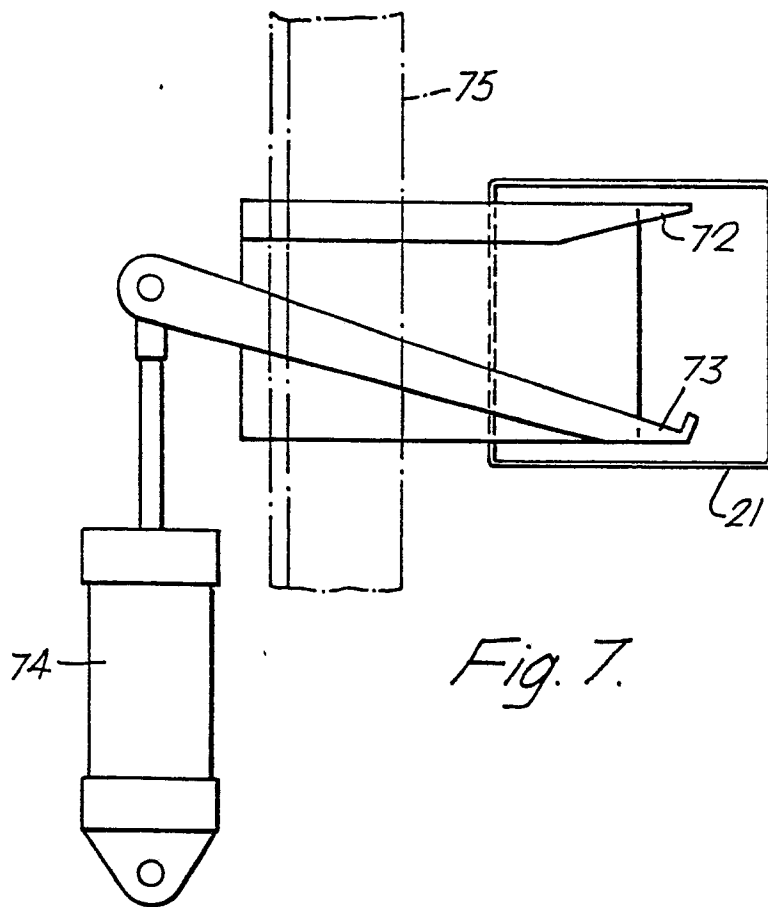
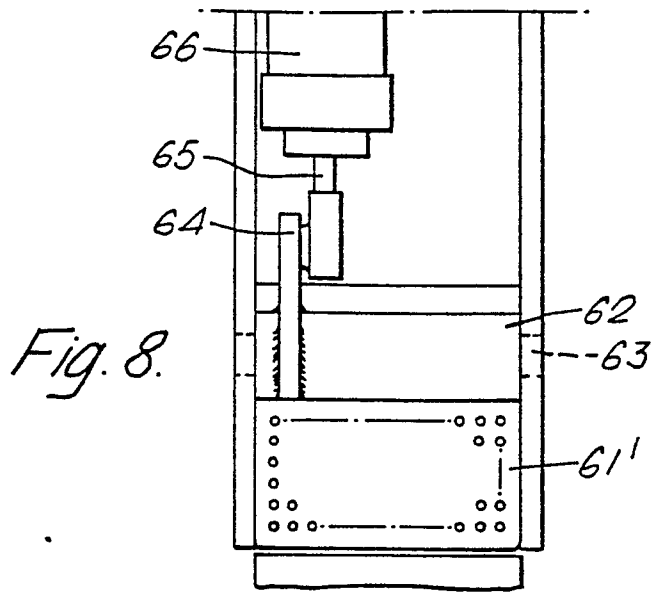

Fig. 6.





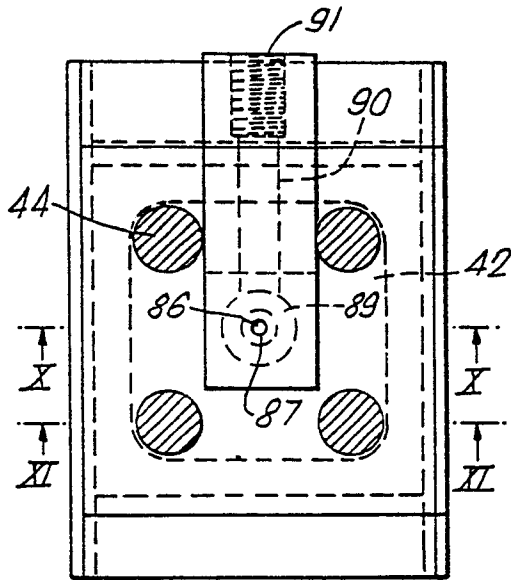

Fig. 9.

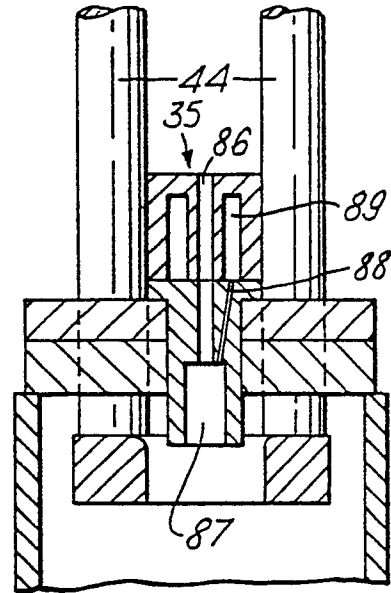

Fig. 10.

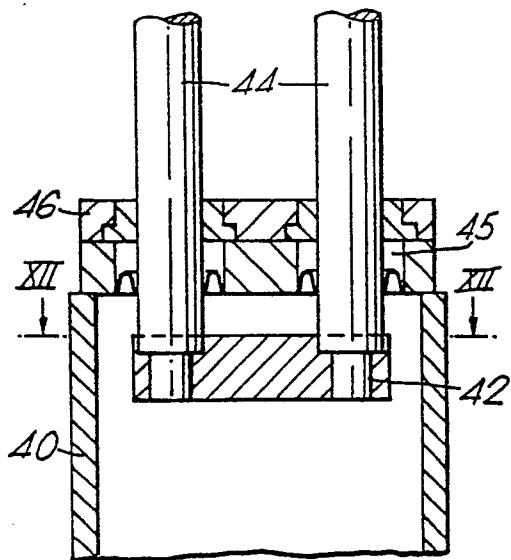

Fig. 11.

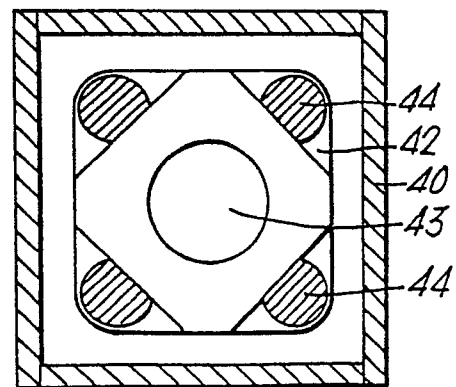

Fig. 12.

Fig. 13.

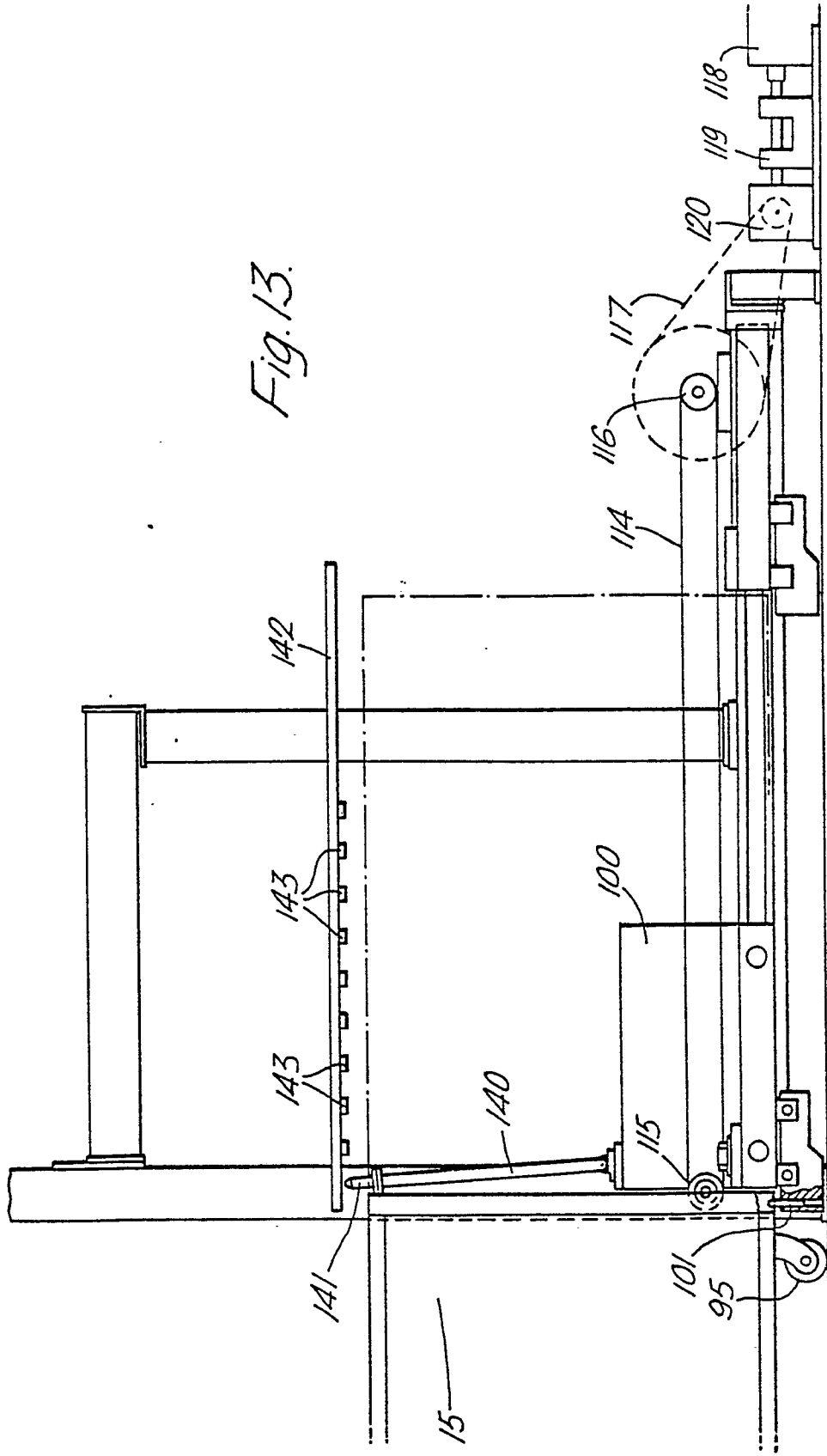

Fig. 14.

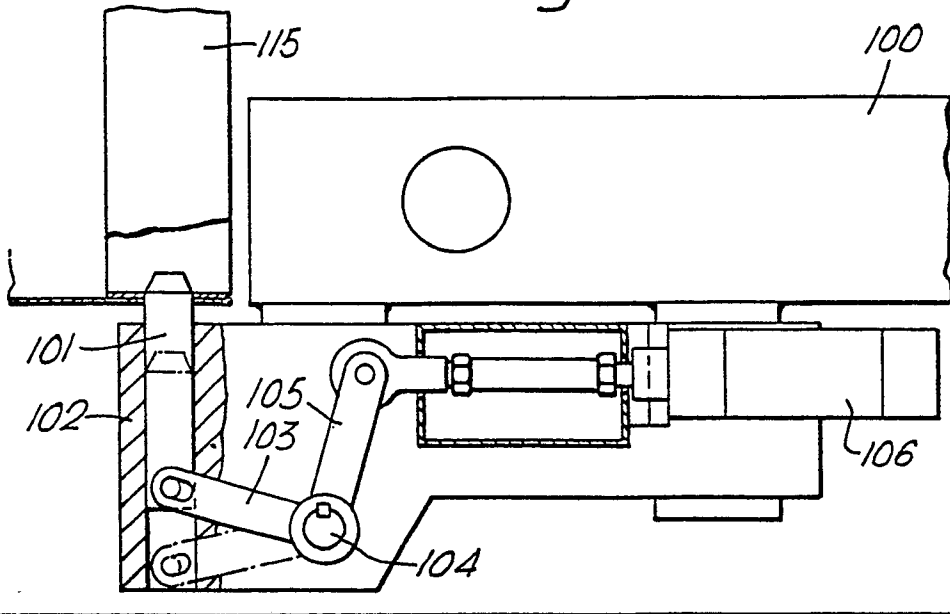

Fig. 15.

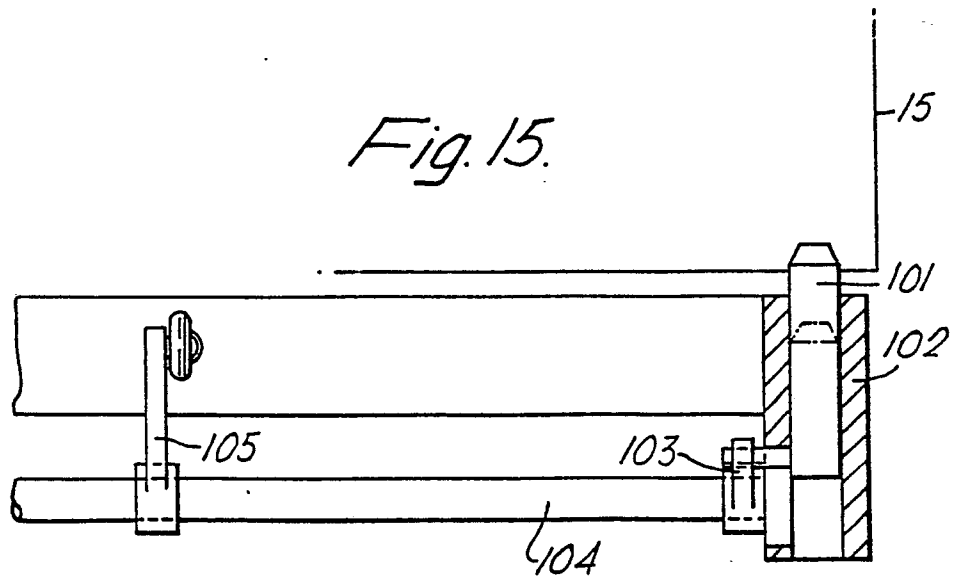

Fig. 17.

