

[54] **IMPELLER WHEEL FOR AN AXIAL FLOW FAN**

3,421,588 1/1969 Saula 416/206
 3,545,884 12/1970 Schroeter et al. 416/205

[75] Inventor: **Henry Valdemar Pedersen, Haslev, Denmark**

Primary Examiner—Everette A. Powell, Jr.
Attorney, Agent, or Firm—Sughrue, Rothwell, Mion, Zinn & Macpeak

[73] Assignee: **Nordisk Ventilator Co. A/S, Naestved, Denmark**

[22] Filed: **Dec. 27, 1973**

[57] **ABSTRACT**

[21] Appl. No.: **429,015**

An impeller wheel for an axial flow fan the vanes of which are arranged in circumferentially spaced apertures in a hollow hub so as to be turnable about their longitudinal axis to adjust the pitch setting of each vane. Each of the apertures is formed with outer and inner counterbored portions and an intermediate central portion, a base portion of one vane and a retaining member being inserted in the outer and inner counterbored portions, respectively, and being connected by bolt means. All retaining members are biased towards the central portions of the apertures by adjustable spring means arranged inside the hollow hub.

[52] U.S. Cl. **416/135; 416/206; 416/207**

[51] Int. Cl.² **F04D 29/36**

[58] Field of Search 416/135, 204-207, 416/209, 248

[56] **References Cited**
UNITED STATES PATENTS

1,645,811	10/1927	Junkers.....	416/206
1,685,323	9/1928	Hansen	416/206
2,307,490	1/1943	Curley	416/207
3,174,553	3/1965	Spears.....	416/206

1 Claim, 1 Drawing Figure

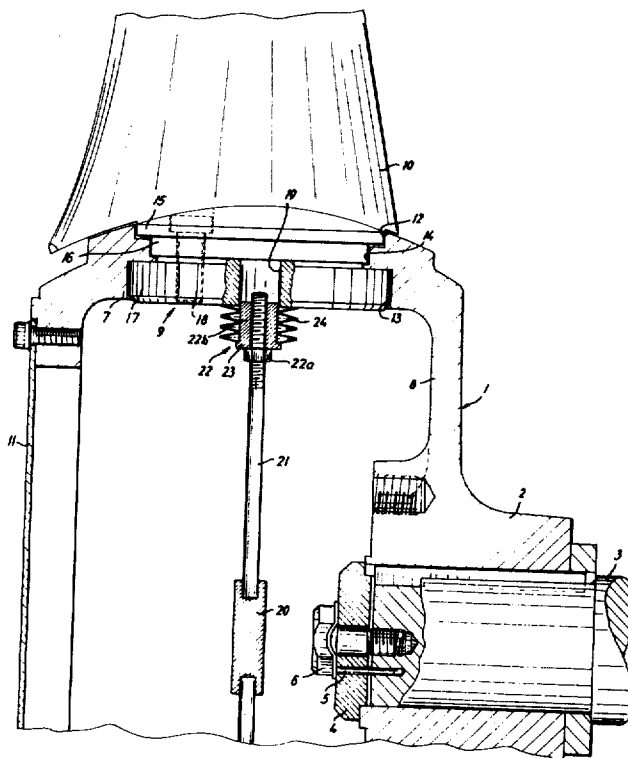

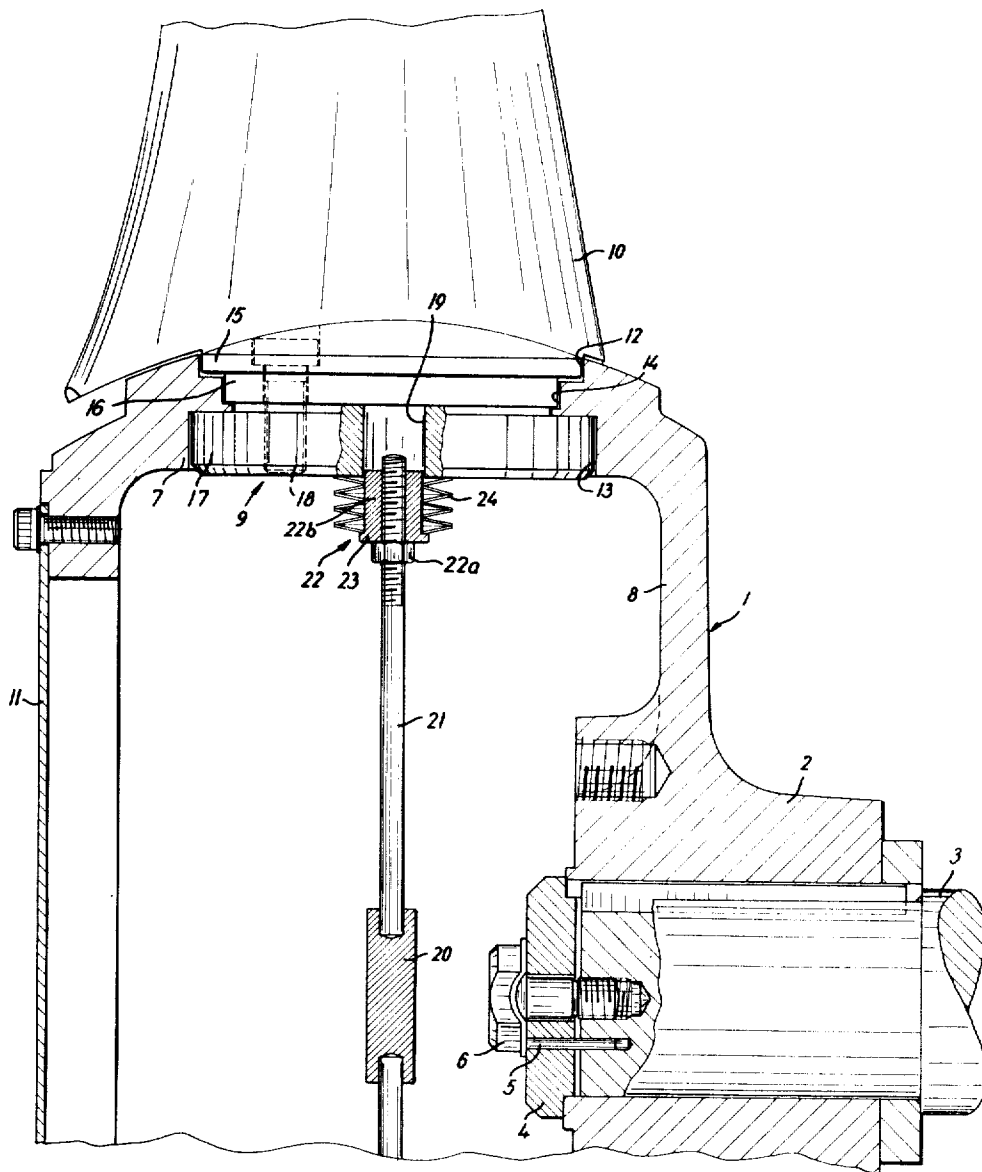

IMPELLER WHEEL FOR AN AXIAL FLOW FAN

The present invention relates to an impeller wheel for an axial flow fan, the vanes of which are arranged in circumferentially spaced apertures in a hollow impeller hub so as to be manually turnable about their longitudinal axis to adjust the pitch setting of the vanes, when the wheel is not rotating.

BACKGROUND OF THE INVENTION

Impeller wheels of the above-mentioned kind are known, for example, from U.S. Pat. No. 3,545,884 to J. W. Schroeter et al. In the prior art structure disclosed therein, each of the circumferentially spaced apertures in the hub is formed with outer and inner counterbored portions extending from the outer and inner surfaces of the hub, respectively, and an intermediate central portion of a restricted cross-sectional area relative to that of each counterbored portion. Each vane has a circular base portion inserted in the outer counterbored portion of an individual one of said apertures, said base portion being connected by bolts extending through the central portion of the aperture with a discshaped retaining member inserted in the inner counterbored portion of the aperture. By means of a spacing member filling out the central portion of the aperture the vane base portion and the retaining member can be firmly clamped together with such a spacing between said parts that the assembly of the vane, the retaining member and the connecting bolts can be turned by hand to adjust the pitch setting of the vane, when the impeller wheel is not rotating. During rotation of the wheel the pitch setting thus adjusted is maintained due to the centrifugal forces which cause the retaining member to be firmly pressed against the annular part of the hub wall extending between the peripheries of the central and inner counterbored portions of the aperture. The advantage obtained thereby is that adjustment of the pitch setting can be made when the wheel is not rotating by turning the vanes manually, without any loosening and retightening of retaining bolts or other locking devices being required.

It has appeared, however, that it is rather difficult to maintain a correctly adjusted pitch setting of the vanes in such an impeller wheel in cases where the wheel is frequently stopped and re-started during operation, if the manual force required for the adjusting movement should be kept sufficiently small. This is presumably due to the fact that during stop and start of the impeller wheel the tangential forces acting on each vane base portion may have a magnitude sufficient to turn the vane when the centrifugal forces decrease.

Moreover, in the prior art structure the production tolerances necessary to obtain uniform pitch adjustment possibilities for all vanes in an impeller wheel are low, so that much accuracy is required in manufacture of the impeller wheel.

SUMMARY OF THE INVENTION

Accordingly, it is an object of the present invention to provide an impeller wheel in which the risk of changing a correctly adjusted pitch setting at frequent stops and starts is eliminated or greatly reduced.

It is a further object of the invention to provide an improved impeller wheel in which the production tolerances necessary to obtain uniform pitch adjustment

possibilities for all vanes are considerably enlarged relative to the above mentioned prior art structure.

It is still an object of the invention to provide an impeller wheel in which the manual force required for the pitch adjustment can be adjusted to a desired value in order to meet different operational conditions.

According to the invention, these objects are achieved by means of an impeller wheel for an axial flow fan, comprising a hollow impeller hub having a central bore for the shaft of a fan driving motor and a plurality of circumferentially spaced apertures extending between the outer and inner surfaces of the hub at right angles to the axis of the central bore, each of said apertures being formed with outer and inner counterbored portions at the outer and inner surfaces of the hub, respectively, and a central portion of restricted cross-sectional area between said counterbored portions; a plurality of vanes, each of which is formed with a disc-shaped base portion having a cross-sectional area exceeding the restricted cross-sectional area of the central portion of each aperture, said base portion being inserted in the outer counterbored portion of an individual one of said apertures; a plurality of flat and disc-shaped retaining members having a cross-sectional area exceeding the restricted cross-sectional area of the central portion of each aperture, each of said retaining members being inserted in the inner counterbored portion of an individual one of said apertures; spacer means filling out the central portion of each aperture between the vane base portion and the retaining member inserted therein; bolt means for connecting the vane base portion in each aperture with the retaining member in the same aperture; and adjustable spring means arranged inside the hollow hub for biasing each retaining member towards the central portion of its associated aperture.

By the above mentioned adjustable spring means each retaining member is effectively biased towards firm engagement with the annular part of the hub wall extending between the central and inner counterbored portions of the aperture so as to secure that the pitch setting is not unintentionally changed during frequent starts and stops of the wheel and, in spite thereof, each vane may still be turned about its longitudinal axis to readjust the pitch setting when desired by exerting a slight pressure on the vane against the direction of the bias force simultaneously with turning of the vane.

DETAILED DESCRIPTION

The invention will be more readily understood from the following description when taken in conjunction with the accompanying drawing, which is a sectional view through part of an impeller wheel embodying the invention, taken along a plan through the axis of the wheel.

The impeller wheel comprises a hub 1 with a central sleeve portion 2 having a bore to receive a shaft 3 of a fan-driving motor not shown. The hub 1 is rigidly secured on shaft 3 by suitable locking means, for example, by a locking disc 4, a pin 5 extending through said disc into a bore in the end of the shaft and a bolt member 6.

Outside the central sleeve portion 2 and integrally therewith, hub 1 is formed with a bowl shaped wall formed by a substantially cylindrical side wall 7 and a flat end wall 8 extending between said side wall and the sleeve portion 2.

In the cylindrical side wall 7 a number of circumferentially spaced apertures are formed to receive the vanes of the impeller wheel, only one of said apertures being shown at 9 in the drawing.

The hollow hub 1 is closed by a cover plate 11 opposite end wall 8.

The aperture 9 is formed with outer and inner counterbored portions 12 and 13 extending from the outer and inner surfaces of side wall 7, respectively, towards a central portion 14 of the aperture, which has a restricted cross sectional area relative to that of each counterbored portion.

Each vane comprises as its main parts a blade portion 10 and a base portion 15 of a substantially circular, disc-shaped configuration matching the outer counterbored portion 12 of aperture 9. In the embodiment shown a spacing member 16 is formed integrally with the base portion 15 as part of the vane 10, said spacing member having a smaller diameter than that of base portion 15, so as to match the restricted cross sectional area of the central portion 14 of aperture 9. The thickness of the spacing member 16 in the longitudinal direction of vane 10 is proportioned to meet the requirements of manual adjustment of the pitch setting, such as explained in the following.

The inner counterbored portion 13 of aperture 9 serves to receive a retaining member 17 of a substantially circular disc-shaped configuration, said retaining member being connected with the vane base portion 15 in the assembled state of the impeller wheel by bolts, one of which is shown by dotted lines at 18.

When assembling the vane 10 and the retaining member 17 during manufacture of the impeller wheel, the bolts as shown at 18 are stressed so as to clamp the vane base portion 15 and the spacing member firmly to the retaining member 17, which in the embodiment shown is formed with tapped bores to receive bolts 18, the thickness of spacing member 16 being proportioned so as to slightly exceed the axial length of the central portion 14 of aperture 9. As a result hereof, the vane 10 and the retaining member 17 connected therewith may be turned manually to adjust the pitch setting of the vane, when the impeller wheel is not rotating.

During rotation of the impeller wheel the retaining member 17 will be pressed firmly by the centrifugal forces against the annular part of the side wall 7 between the peripheries of the central and inner counterbored portions 14 and 13, respectively, so as to maintain the pitch setting once adjusted.

However, if further precautions are not taken, there will be a risk for the adjusted pitch setting to be changed unintentionally, particularly in cases where frequent starts and stops occur during operation of the impeller wheel, such as mentioned hereinbefore. Furthermore, since the pitch adjustment is performed for one vane at a time until the pitch setting has been adjusted for the total number of vanes, this adjustment operation taking place in the rest condition of the impeller wheel, it may happen that the pitch setting of a vane which has already been adjusted is changed during adjustment of other vanes. Therefore, the pitch setting adjustment may be a rather difficult operation.

According to the invention, these drawbacks are eliminated or, at least, considerably reduced in that each retaining member 17 is spring-biased towards the central portion 14 of its associated aperture 9, as a result of which the retaining member will be in a rela-

tively firm engagement with the above mentioned annular wall part between the peripheries of the central and inner counterbored portions 14 and 13, respectively, of the aperture 9, even in the rest condition of the impeller wheel.

In the embodiment illustrated in the drawing, the retaining member 17 is formed with a central bore 19, and the impeller wheel is provided with adjustable spring means for biasing the retaining member, which comprise a central hub member 20 arranged inside the hub 1 and a number of arms 21, corresponding to the total number of vanes, extending radially with an evenly angular distribution from said hub member 20 into the central bore 19 of each retaining member 17, each of said arms 21 having a threaded outer end for a nut member 22 having in one end a diameter smaller than that of the central bore 19 in the retaining member and being formed in the other end with an enlarged collar portion 23 forming an abutment face for one end of a disc spring 24 surrounding nut member 22, an abutment face for the other end of said spring 24 being formed by the underside of retaining member 17.

It is readily understood that in the impeller wheel according to the invention each retaining member is thereby pressed against the annular part of side wall 7 between the central and inner counterbored portions 14 and 13, respectively, of its associated aperture 9 by a bias force, the magnitude of which may be adjusted by adjusting the compression of disc spring 24 by means of nut member 22.

As shown in the drawing, the nut member 22 may consist of a separate nut 22a and a bushing 22b of the above mentioned shape to be inserted with one end into the central aperture 19 of retaining member 17 and incorporating in its other end the collar portion 23.

Furthermore, while the spring support means consisting of hub members 20 and 21 is shown to be arranged in the impeller without any connection to the walls of impeller hub 1, it will be appreciated that the hub member 20 may be secured on drive shaft 8 for rotation together with hub 1.

It will also be appreciated that it is not essential to the invention whether rigid connection by bolt means 18 between each vane base portion 15 and its associated retaining member is obtained by forming retaining member 17 as a nut member to receive bolts 18 or by means of a separate nut engaging each bolt 18 at the underside of the retaining member.

In the embodiment shown the adjustable spring means according to the invention may be arranged inside the hollow impeller hub in that the control hub member 20 and the number of arms 21 are formed as separate parts, the hub member being provided with a number of circumferentially spaced holes to receive arms 21 and each arm 21 being threaded in one end through a length portion sufficient to position said end of the arm with nut member 22 and spring 24 arranged thereon in the central bore 19 of a retaining member 17 through the opening covered by cover plate 11 and thereafter position the opposite end of arm 21 into its associated circumferential hole in central hub member 20, subsequent to which the position of nut member 22 on the outer end of each arm 21 is adjusted to obtain the correct bias of retaining member 17.

What is claimed is:

1. In an impeller wheel for an axial flow fan, having

5

a hollow impeller hub with a central bore for the shaft of a fan driving motor and a plurality of circumferentially spaced apertures extending between the outer and inner surfaces of the hub at right angles to the axis of the central bore, each of said apertures being formed with outer and inner counterbored portions at the outer and inner surfaces of the hub, respectively, and a central portion of restricted cross-sectional area between said counterbored portions;

a plurality of vanes, each of which is formed with a discshaped base portion having a cross-sectional area exceeding the restricted cross-sectional area of the central portion of each aperture, said base portion being inserted in the outer counterbored portion of an individual one of said apertures;

a plurality of flat and disc-shaped retaining members having a cross-sectional area exceeding the restricted cross-sectional area of the central portion of each aperture, each of said retaining members being inserted in the inner counterbore portion of an individual one of said apertures and each having a central bore therethrough;

spacer means filling out the central portion of each aperture between the vane base portion and the re-

5
10
15
20
25

30

35

40

45

50

55

60

65

6

taining member inserted therein; and
 bolt means for connecting the vane base portion in each aperture with the retaining member in the same aperture; the improvement wherein adjustable spring means are arranged inside the hollow hub for biasing each retaining member towards the central portion of its associated aperture, said adjustable spring means comprising:

- a. a central hub member arranged inside the impeller hub;
- b. a plurality of arms extending radially from said central hub member into the central bores of the retaining members, each arm having a threaded end adjacent the retaining members;
- c. a nut member threadingly engaged on the threaded end of each arm, said nut member having the radially outward end of a diameter smaller than that of the central bore of the retaining member and an enlarged collar portion on the other end; and
- d. a spring disposed between said enlarged collar portion of said nut member and said retaining member.

* * * * *