

(19) World Intellectual Property Organization
International Bureau



(43) International Publication Date
7 October 2010 (07.10.2010)

PCT

(10) International Publication Number
WO 2010/113441 A1

- (51) International Patent Classification:
B41J 11/00 (2006.01) B41J 15/04 (2006.01)
- (21) International Application Number:
PCT/JP2010/002161
- (22) International Filing Date:
26 March 2010 (26.03.2010)
- (25) Filing Language:
English
- (26) Publication Language:
English
- (30) Priority Data:
2009-088440 31 March 2009 (31.03.2009) JP
2009-088441 31 March 2009 (31.03.2009) JP
2009-088456 31 March 2009 (31.03.2009) JP
2009-088460 31 March 2009 (31.03.2009) JP
2009-088468 31 March 2009 (31.03.2009) JP
2009-156355 30 June 2009 (30.06.2009) JP
2009-156357 30 June 2009 (30.06.2009) JP
2009-156369 30 June 2009 (30.06.2009) JP
2009-156371 30 June 2009 (30.06.2009) JP

- (72) Inventors; and
- (75) Inventors/Applicants (for US only): YAMAGUCHI, Koshiro [JP/JP]; c/o BROTHER KOGYO KABUSHIKI KAISHA, 15-1, Naeshiro-cho, Mizuho-ku, Nagoya-shi, Aichi, 4678561 (JP). HORIUCHI, Takashi [JP/JP]; c/o BROTHER KOGYO KABUSHIKI KAISHA, 15-1, Naeshiro-cho, Mizuho-ku, Nagoya-shi, Aichi, 4678561 (JP). SAGO, Akira [JP/JP]; c/o BROTHER KOGYO KABUSHIKI KAISHA, 15-1, Naeshiro-cho, Mizuho-ku, Nagoya-shi, Aichi, 4678561 (JP). IRIYAMA, Yasuhiro [JP/JP]; c/o BROTHER KOGYO KABUSHIKI KAISHA, 15-1, Naeshiro-cho, Mizuho-ku, Nagoya-shi, Aichi, 4678561 (JP). SHIBATA, Yasuhiro [JP/JP]; c/o BROTHER KOGYO KABUSHIKI KAISHA, 15-1, Naeshiro-cho, Mizuho-ku, Nagoya-shi, Aichi, 4678561 (JP). NAGAE, Tsuyoshi [JP/JP]; c/o BROTHER KOGYO KABUSHIKI KAISHA, 15-1, Naeshiro-cho, Mizuho-ku, Nagoya-shi, Aichi, 4678561 (JP). KATO, Masato [JP/JP]; c/o BROTHER KOGYO KABUSHIKI KAISHA, 15-1, Naeshiro-cho, Mizuho-ku, Nagoya-shi, Aichi, 4678561 (JP). IMAMAKI, Teruo [JP/JP]; c/o BROTHER KOGYO KABUSHIKI KAISHA, 15-1, Naeshiro-cho, Mizuho-ku, Nagoya-shi, Aichi, 4678561 (JP).

- (71) Applicant (for all designated States except US):
BROTHER KOGYO KABUSHIKI KAISHA [JP/JP];
15-1, Naeshiro-cho, Mizuho-ku, Nagoya-shi, Aichi,
4678561 (JP).

[Continued on next page]

(54) Title: TAPE CASSETTE AND TAPE PRINTER

[Fig. 13]

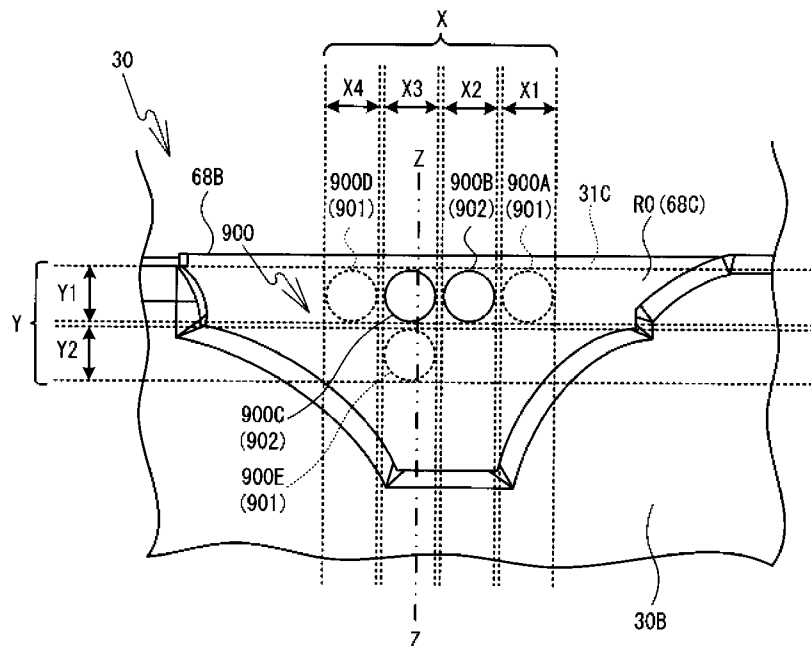

(57) Abstract: A tape cassette 30 includes a rear indentation 68C that is provided on a rear edge side of a bottom wall 30B, between the periphery of a cassette case and a tape housing area. A rear indicator portion 900 that indicates color information relating to a tape is provided in a specified area R0 included in the rear indentation 68C. A tape color is indicated by whether or not a protrusion is formed in a lateral information section Y1, among a plurality of lateral information sections Y included in the rear indicator portion 900. A character color is indicated by whether or not a protrusion is formed in a lateral information section Y2.

WO 2010/113441 A1

(74) **Agents:** YAMAMOTO, Hisashi et al.; 6th-floor, Kami-maezu KD-bldg., 10-32, Osu 4-chome, Naka-ku, Nagoya-shi, Aichi, 4600011 (JP).

(81) **Designated States** (*unless otherwise indicated, for every kind of national protection available*): AE, AG, AL, AM, AO, AT, AU, AZ, BA, BB, BG, BH, BR, BW, BY, BZ, CA, CH, CL, CN, CO, CR, CU, CZ, DE, DK, DM, DO, DZ, EC, EE, EG, ES, FI, GB, GD, GE, GH, GM, GT, HN, HR, HU, ID, IL, IN, IS, KE, KG, KM, KN, KP, KR, KZ, LA, LC, LK, LR, LS, LT, LU, LY, MA, MD, ME, MG, MK, MN, MW, MX, MY, MZ, NA, NG, NI, NO, NZ, OM, PE, PG, PH, PL, PT, RO, RS, RU, SC, SD, SE, SG, SK, SL, SM, ST, SV, SY, TH, TJ, TM, TN, TR, TT, TZ, UA, UG, US, UZ, VC, VN, ZA, ZM, ZW.

(84) **Designated States** (*unless otherwise indicated, for every kind of regional protection available*): ARIPO (BW, GH, GM, KE, LR, LS, MW, MZ, NA, SD, SL, SZ, TZ, UG, ZM, ZW), Eurasian (AM, AZ, BY, KG, KZ, MD, RU, TJ, TM), European (AT, BE, BG, CH, CY, CZ, DE, DK, EE, ES, FI, FR, GB, GR, HR, HU, IE, IS, IT, LT, LU, LV, MC, MK, MT, NL, NO, PL, PT, RO, SE, SI, SK, SM, TR), OAPI (BF, BJ, CF, CG, CI, CM, GA, GN, GQ, GW, ML, MR, NE, SN, TD, TG).

Published:

- with international search report (*Art. 21(3)*)
- before the expiration of the time limit for amending the claims and to be republished in the event of receipt of amendments (*Rule 48.2(h)*)

Description

Title of Invention: TAPE CASSETTE AND TAPE PRINTER

Technical Field

[0001] The present invention relates to a tape cassette that is detachably installed in a tape printer and a tape printer that is configured to detachably house a tape cassette therein and that performs printing on a tape included in the tape cassette.

Background Art

[0002] A tape cassette has been known that, when installed in a housing portion of a tape printer, selectively presses a plurality of detecting switches provided on the cassette housing portion to cause the tape printer to detect color information of the tape cassette (a tape color, a character color, etc.). More specifically, a cassette detection portion is provided on a section of the bottom surface of the tape cassette, where through-holes are formed in a pattern corresponding to the color information. When the tape cassette is installed in the cassette housing portion, the plurality of detecting switches, which are constantly urged in an upward direction, are selectively pressed in accordance with the pattern of the through-holes formed in the cassette detection portion. The tape printer detects the color information of the tape cassette installed in the cassette housing portion based on a combination of the pressed and non-pressed switches among the plurality of detecting switches.

Citation List

Patent Literature

[0003] PTL 1: Japanese Laid-Open Patent Publication 4-133756
PTL 2: Japanese Patent 3543659

Summary of Invention

[0004] The pattern of through-holes formed in the cassette detection portion is basically only designed to allow the tape printer to detect the color information. Accordingly, different patterns are allocated randomly in accordance with the color information. In other words, the patterns of through-holes are not formed in a pattern in accordance with rules to allow them to be identified from the outward appearance. Therefore, it is difficult for a person to visually identify the color information. For that reason, for example, in a tape cassette manufacturing process, it may be difficult for a worker to visually identify a tape and an ink ribbon etc. that should be mounted inside the cassette case from the external appearance of the tape cassette.

[0005] An object of the present invention is to provide a tape cassette that allows color information to be recognized by visually checking an external appearance of the tape cassette. Another object of the present invention is to provide a tape printer that, in a

case where a tape cassette that allows color information to be identified by visually checking an external appearance thereof is installed, is capable of obtaining same detection results for the color information as identified by the visual checking.

[0006] A tape cassette according to a first aspect of the present invention includes a housing, at least one tape, and a color indicator portion. The housing includes a top wall having a top surface, a bottom wall having a bottom surface, and a side wall. The top wall and the bottom wall each have a rectangular shape whose longitudinal direction is a left-and-right direction of the housing. The top wall, the bottom wall, and the side wall define a periphery of the housing. The at least one tape is mounted in a tape housing area defined within the periphery. The color indicator portion is disposed between the tape housing area and the periphery, and in a specified area adjacent to the tape housing area on a rear edge side of the bottom wall. The color indicator portion indicates color information relating to the at least one tape, and includes a plurality of lateral information sections that are a plurality of strip-shaped sections extending along the left-and-right direction of the housing and aligned in a front-rear direction of the housing. A presence or an absence of a first protrusion that protrudes downward from the bottom surface and is formed in a first lateral information section indicates, as the color information, a base material color of the at least one tape. The first lateral information section is one of the plurality of lateral information sections and adjoining the rear edge of the bottom wall.

[0007] A person can identify, as the color information, the base material color of the at least one tape, simply by looking at the color indicator portion of the tape cassette and checking the presence or absence of the first protrusion formed in the first lateral information section.

[0008] In the tape cassette according to the first aspect, a presence or an absence of a second protrusion that protrudes downward from the bottom surface and is formed in a second lateral information section may indicate, as the color information, a print color of the at least one tape. The second lateral information section is another of the plurality of lateral information sections and located to the front of the first lateral information section.

[0009] In such a case, the person can identify the print color of the at least one tape, simply by looking at the color indicator portion of the tape cassette and checking the presence or absence of the second protrusion formed in the second lateral information section.

[0010] The tape cassette according to the first aspect may further include an ink ribbon mounted in a ribbon housing area defined within the periphery, and the print color may be an ink color of the ink ribbon.

[0011] In such a case, the person can identify the ink color as the print color, simply by visually checking the second lateral information section.

- [0012] In the tape cassette according to the first aspect, the tape housing area may be located to a rear side within the housing, and the ribbon housing area may be located to a front side within the housing.
- [0013] In such a case, the tape and the ink ribbon are aligned in the front-rear direction inside the housing, corresponding to the arrangement order in the front-rear direction of the first and second lateral information sections. Therefore, the person can accurately identify the base material color indicated by the first lateral information section and the tape color indicated by the second lateral information section.
- [0014] In the tape cassette according to the first aspect, the at least one tape may include a heat-sensitive color development tape, and the print color may be a color developed by the heat-sensitive color development tape.
- [0015] In such a case, the person can identify the color developed by the heat-sensitive color development tape as the print color, simply by visually checking the second lateral information section.
- [0016] In the tape cassette according to the first aspect, if the color indicator portion indicates a special color as the base material color, the protrusion may be formed in a specified position of the first lateral information section.
- [0017] In such a case, the person can identify the base material color as the special color if the protrusion is formed in the specified position of the first lateral information section.
- [0018] In the tape cassette according to the first aspect, if the protrusion is not formed in the second lateral information section, the color indicator portion may indicate that the print color is black. On the other hand, if the protrusion is formed in the second lateral information section, the color indicator portion may indicate that the print color is a color other than black.
- [0019] In such a case, the person can identify whether or not the print color is black, simply by visually checking the second lateral information section.
- [0020] In the tape cassette according to the first aspect, the tape housing area may include a first tape housing area and a second tape housing area. The first and second tape housing areas may each have a generally circular shape in a plan view, and may be aligned with each other in the left-and-right direction such that outer peripheral edges of the first and second tape housing areas contact with each other. Then, the at least one tape may be wound and mounted in at least one of the first and second tape housing areas. In addition, the color indicator portion may include a reference vertical information section that is a strip-shaped section extending along the front-rear direction of the housing and that includes a reference line, which is an imaginary line extending along the front-rear direction and passing through a contact point of the outer peripheral edges of the first and second tape housing areas. Then, the protrusion provided in at least one of the first and second lateral information sections may be

provided at least in the reference vertical information section.

- [0021] In such a case, the person can identify the reference vertical information section using the contact point of the outer peripheral edges of the two tape housing areas as a reference. Then, the person can identify the color information simply by checking whether the protrusion is formed in each of areas where the reference vertical information section intersect and overlap with the first and second lateral information sections.
- [0022] In the tape cassette according to the first aspect, the color indicator portion may include a plurality of vertical information sections that are a plurality of strip-shaped sections extending along the front-rear direction of the housing and aligned in the left-and-right direction of the housing. The plurality of vertical information sections may include the reference vertical information section and a subordinate vertical information section arranged in parallel with the reference vertical information section. Then, the protrusion provided in at least one of the first lateral information section and the second lateral information section may be provided in at least one of the reference vertical information section and the subordinate vertical information section.
- [0023] In such a case, the person can identify the subordinate vertical information section using the reference vertical information section as a reference. Then, the person can identify the color information simply by checking whether the protrusion is formed in each of areas where the plurality of vertical information sections intersect and overlap with the first and second lateral information sections.
- [0024] In the tape cassette according to the first aspect, the color indicator portion may include a plurality of vertical information sections that are a plurality of strip-shaped sections extending along the front-rear direction of the housing and aligned in the left-and-right direction of the housing. Then, if the protrusion adjoining the rear edge of the bottom wall is formed in a predetermined vertical information section among the plurality of vertical information sections, and if a front side of the protrusion is a surface portion separately disposed from the rear edge, an area where the predetermined vertical information section and the first lateral information section intersect and overlap with each other may be the protrusion, and an area where the predetermined vertical information section and the second lateral information section intersect and overlap with each other may be the surface portion.
- [0025] In such a case, the person can identify a range in which the second lateral information section is provided, using the surface portion and the protrusion arranged in the front-rear direction. Then, the person can identify the print color by checking whether or not the protrusion is formed in the second lateral information section.
- [0026] In the tape cassette according to the first aspect, if the color indicator portion includes the protrusion formed in at least two of a plurality of overlapping areas, the protrusion

may be formed as protrusions separated from each other in each of the at least two of the plurality of overlapping areas. The overlapping areas are areas where the plurality of lateral information sections and the plurality of vertical information sections intersect and overlap with each other.

[0027] In such a case, the person can easily distinguish and recognize the protrusions.

[0028] In the tape cassette according to the first aspect, if the color indicator portion includes the protrusion formed in at least two of a plurality of overlapping areas, the protrusion may include at least one protrusion that is formed over the at least two of the plurality of overlapping areas. The overlapping areas are areas where the plurality of lateral information sections and the plurality of vertical information sections intersect and overlap with each other.

[0029] In such a case, in manufacturing the tape cassette, for example, the protrusion can be formed continuously over the adjacent vertical information sections. Therefore, the tape cassette can be manufactured easily. In addition, the protrusion formed continuously over the adjacent vertical information sections is different in shape from the protrusion formed independently. Therefore, the person can recognize the difference in shape and can easily identify the color information.

[0030] In the tape cassette according to the first aspect, the bottom surface may include a lower end surface portion, a common surface portion, and a reference surface portion. The lower end surface portion may be a flat portion located at a lower end of the housing. The common surface portion may be a flat portion located at a fixed position in the vertical direction of the housing regardless of a width of the at least one tape mounted in the tape housing area. The common surface portion may be located at a higher position than the lower end surface portion, and may extend parallel to the lower end surface portion. The reference surface portion may be a flat portion located at a higher position than the common surface portion in the vertical direction and may extend parallel to the common surface portion. A pair of corner portions adjacent to the tape housing area on the rear edge side may be a pair of common height portions each including the common surface portion. The color indicator portion may be provided in the reference surface portion disposed between the pair of common height portions. Then, the protrusion may protrude downward from the reference surface portion.

[0031] In such a case, the color indicator portion can be provided to the tape cassette without narrowing the tape housing area. In addition, the person can visually check the color indicator portion from the bottom surface side.

[0032] A tape printer according to a second aspect of the present invention includes a tape cassette, a cassette housing portion, a feeding device, a printing device, a plurality of detecting switches, a table storage device, and a color identifying device. The tape cassette includes a housing, at least one tape, and a color indicator portion. The

housing includes a top wall having a top surface, a bottom wall having a bottom surface, and a side wall. The top wall and the bottom wall each have a rectangular shape whose longitudinal direction is a left-and-right direction of the housing. The top wall, the bottom wall, and the side wall define a periphery of the housing. The at least one tape is mounted in a tape housing area defined within the periphery. The color indicator portion is disposed between the tape housing area and the periphery, and in a specified area adjacent to the tape housing area on a rear edge side of the bottom wall. The color indicator portion indicates color information relating to the at least one tape, and includes a plurality of lateral information sections that are a plurality of strip-shaped sections extending along the left-and-right direction of the housing and aligned in a front-rear direction of the housing. In the cassette housing portion, the tape cassette is detachably installed. The feeding device feeds the at least one tape along a predetermined feed path from the housing of the tape cassette installed in the cassette housing portion. The printing device performs printing on a print medium tape, which is one of the at least one tape, fed by the feeding device. The plurality of detecting switches protrudes toward the bottom surface of the housing of the tape cassette installed in the cassette housing portion, and detects identification information for identifying the color information relating to the at least one tape mounted in the housing. The table storage device stores a color information table in which the identification information is associated with the color information. The color identifying device identifies, with reference to the color information table, the color information associated with the identification information detected by the plurality of detecting switches as the color information relating to the at least one tape mounted in the housing. A presence or absence of a first protrusion that protrudes downward from the bottom surface and is formed in a first lateral information section indicates, as the color information, a base material color of the at least one tape. The first lateral information section is one of the plurality of lateral information sections and adjoining the rear edge of the bottom wall. When the tape cassette is installed in the cassette housing portion, the plurality of detecting switches detects information indicating one of a pressed state and a non-pressed state of each of the plurality of detecting switches as the identification information. Then, the color identifying device identifies, as the color information, the base material color associated with the identification information detected by the plurality of detecting switches.

[0033] A person can identify, as the color information, the base material color of the at least one tape, simply by looking at the color indicator portion of the tape cassette and checking the presence or absence of the first protrusion formed in the first lateral information section. When the tape cassette is installed in the tape printer, the tape printer can identify the same base color as identified by the visual check based on

detection results of the plurality of detecting switches.

[0034] In the tape printer according to the second aspect, a presence or an absence of a second protrusion that protrudes downward from the bottom surface and is formed in a second lateral information section may indicate, as the color information, a print color of the at least one tape. The second lateral information section is another of the plurality of lateral information sections and located to the front of the first lateral information section. Then, the color identifying device may identify, as the color information, the print color associated with the identification information detected by the plurality of detecting switches.

[0035] In such a case, the person can identify the print color of the at least one tape, simply by looking at the color indicator portion of the tape cassette and checking the presence or absence of the second protrusion formed in the second lateral information section. When the tape cassette is installed in the tape printer, the tape printer can identify the same print color as identified by the visual check based on detection results of the plurality of detecting switches.

[0036] In the tape printer according to the second aspect, the plurality of detecting switches may include a first area detecting switch that opposes the first lateral information section when the tape cassette is installed in the cassette housing portion, and a second area detecting switch that opposes the second lateral information section. The first area detecting switch may be selectively pressed by the protrusion formed in the first lateral information section to thereby detect first area information as the identification information. The second area detecting switch may be selectively pressed by the protrusion formed in the second lateral information section to thereby detect second area information as the identification information. Then, the color identifying device may identify, with reference to the color information table, the base material color associated with the first area information detected by the first area detecting switch, and the print color associated with the second area information detected by the second area detecting switch.

[0037] In such a case, the tape printer can identify the base material color based on the detection result of the first area detecting switch regardless of any other detection switch, and the tape printer can identify the print color based on the detection result of the second area detecting switch regardless of any other detection switch. Therefore, processing to identify the color information can be simplified.

[0038] In the tape printer according to the second aspect, if the color indicator portion indicates a special color as the base material color, the protrusion may be formed in a specified position of the first lateral information section, and if the first area information indicates the pressed state of the first area detecting switch that opposes the specified position and the non-pressed state of the first area detecting switch that does

not oppose the specified position, the color identifying device may at least identify, as the color information, that the base material color is the special color.

[0039] In such a case, the person can identify the base material color as the special color if the protrusion is formed in the specified position of the first lateral information section. The tape printer can identify that the base material color is the special color, just as in the case of human visual check, based on the pressed state of the first area detecting switch that opposes the specified position and the non-pressed state of the first area detecting switch that does not oppose the specified position.

[0040] In the tape printer according to the second aspect, if the protrusion is not formed in the second lateral information section in the color indicator portion of the tape cassette, the color indicator portion may indicate that the print color is black, and if the protrusion is formed in the second lateral information section, the color indicator portion may indicate that the print color is a color other than black. Then, if the second area information indicates the non-pressed state of the second area detecting switch, the color identifying device may at least identify, as the color information, that the print color is black, and if the second area information indicates the pressed state of the second area detecting switch, the color identifying device may at least identify, as the color information, that the print color is the color other than black.

[0041] In such a case, the person can identify whether or not the print color is black, simply by visually checking the second lateral information section. The tape printer can identify whether or not the print color is black, just as in the case of human visual check, based on the non-pressed or pressed state of the second area detecting switch.

[0042] In tape printer according to the second aspect, the tape cassette may include an ink ribbon mounted in an ink ribbon housing area defined within the periphery of the housing, and the print color may be an ink color of the ink ribbon.

[0043] In such a case, the person can identify the ink color of the ink ribbon as the print color, simply by visually checking the second lateral information section. The tape printer can identify the ink color of the ink ribbon as the print color, just as in the case of human visual check, based on the detection result of the second area detecting switch.

[0044] In the tape printer according to the second aspect, the at least one tape may include a heat-sensitive color development tape, and the print color may be a color developed by the heat-sensitive color development tape.

[0045] In such a case, the person can identify the color developed by the heat-sensitive color development tape as the print color, simply by visually checking the second lateral information section. The tape printer can identify the color developed by the heat-sensitive color development tape as the print color, just as in the case of human visual check, based on the detection result of the second area detecting switch.

[0046] In the tape printer according to the second aspect, the tape housing area may include a first tape housing area and a second tape housing area. The first and second tape housing areas may each have a generally circular shape in a plan view, and may be aligned with each other in the left-and-right direction such that outer peripheral edges of the first and second tape housing areas contact with each other. Then, the at least one tape may be wound and mounted in at least one of the first and second tape housing areas. In addition, the color indicator portion may include a reference vertical information section that is a strip-shaped section extending along the front-rear direction of the housing and that includes a reference line, which is an imaginary line extending along the front-rear direction and passing through a contact point of the outer peripheral edges of the first and second tape housing areas. Then, the protrusion provided in at least one of the first and second lateral information sections may be provided at least in the reference vertical information section. Further, the plurality of detecting switches may include at least two detecting switches that correspond to two areas where the reference vertical information section intersects and overlaps with the first lateral information section and the second lateral information section, respectively.

[0047] In such a case, the person can identify the reference vertical information section using the contact point of the peripheral edges of the two tape housing areas as a reference. Then, the person can identify the color information simply by checking whether the protrusion is formed in each of areas where the reference vertical information section intersect and overlap with the first and second lateral information sections. The tape printer can identify the color information, just as in the case of human visual check, based on the detection results of the two detecting switches that correspond to the two areas where the reference vertical information section intersects and overlaps with the first lateral information section and the second lateral information section, respectively.

[0048] In the tape printer according to the second aspect, the color indicator portion may include a plurality of vertical information sections that are a plurality of strip-shaped sections extending along the front-rear direction of the housing and aligned in the left-and-right direction of the housing. The plurality of vertical information sections may include the reference vertical information section and a subordinate vertical information section arranged in parallel with the reference vertical information section. The protrusion provided in at least one of the first lateral information section and the second lateral information section may be provided in at least one of the reference vertical information section and the subordinate vertical information section. Then, each of the plurality of detecting switches may be provided corresponding to one of a plurality of areas where the plurality of vertical information sections intersects and overlaps with the first lateral information section and the second lateral information

section respectively.

[0049] In such a case, the person can identify the subordinate vertical information section using the reference vertical information section as a reference. Then, the person can identify the color information simply by checking whether the protrusion is formed in each of areas where the plurality of vertical information sections intersect and overlap with the first and second lateral information sections. The tape printer can identify the color information, just as in the case of human visual check, based on the detection result of each of the plurality of detecting switches that corresponds to one of a plurality of areas where the plurality of vertical information sections intersect and overlap with the first lateral information section and the second lateral information section respectively.

[0050] In the tape printer according to the second aspect, the bottom surface of the housing may include a lower end surface portion, a common surface portion, and a reference surface portion. The lower end surface portion may be a flat portion located at a lower end of the housing. The common surface portion may be a flat portion located at a fixed position in the vertical direction of the housing regardless of a width of the at least one tape mounted in the tape housing area. The common surface portion may be located at a higher position than the lower end surface portion, and may extend parallel to the lower end surface portion. The reference surface portion may be a flat portion located at a higher position than the common surface portion in the vertical direction and may extend parallel to the common surface portion. A pair of corner portions adjacent to the tape housing area on the rear edge side may be a pair of common height portions each including the common surface portion. The color indicator portion may be provided in the reference surface portion disposed between the pair of common height portions. Then, the protrusion may protrude downward from the reference surface portion.

[0051] In such a case, the color indicator portion can be provided to the tape cassette without narrowing the tape housing area. Moreover, the person can visually check the color indicator portion from the bottom surface side. Further, the detecting switches of the tape printer that protrude from below can be opposed to the color indicator portion.

Brief Description of Drawings

[0052] [fig.1]FIG. 1 is a perspective view of a tape printer 1 when a cassette cover 6 is closed.
[fig.2]FIG. 2 is a perspective view illustrating a tape cassette 30 and a cassette housing portion 8.

[fig.3]FIG. 3 is a plan view of the cassette housing portion 8 with a laminated type tape cassette 30 installed, when a platen holder 12 is at a standby position.

[fig.4]FIG. 4 is a plan view of the cassette housing portion 8 with the laminated type

tape cassette 30 installed, when the platen holder 12 is at a print position.

[fig.5]FIG. 5 is a plan view of the cassette housing portion 8 with a receptor type tape cassette 30 installed, when the platen holder 12 is at the print position.

[fig.6]FIG. 6 is a plan view of the cassette housing portion 8 with a thermal type tape cassette 30 installed, when the platen holder 12 is at the print position.

[fig.7]FIG. 7 is a cross-sectional view taken along a line I-I in FIG. 2 as seen in the direction of the arrows.

[fig.8]FIG. 8 is a partial enlarged view of a cassette-facing surface 12B on which is provided an arm detection portion 200.

[fig.9]FIG. 9 is a block diagram showing an electrical configuration of the tape printer 1;

[fig.10]FIG. 10 is an external perspective view of the tape cassette 30 as seen from a top surface side.

[fig.11]FIG. 11 is an external perspective view of the tape cassette 30 as seen from a bottom surface side.

[fig.12]FIG. 12 is an enlarged and exploded perspective view of an arm portion 34 of the tape cassette 30.

[fig.13]FIG. 13 is a bottom view of the tape cassette 30, in which a rear indentation 68C is enlarged.

[fig.14]FIG. 14 is a plan view of the tape cassette 30, in which the rear indentation 68C is enlarged with a top case 31A removed.

[fig.15]FIG. 15 is a cross-sectional view taken along a line III-III in FIG. 8 as seen in the direction of the arrows, and illustrates a state where the arm detection portion 200 shown in FIG. 8 opposes an arm indicator portion 800 shown in FIG. 12.

[fig.16]FIG. 16 is a cross-sectional view taken along a line II-II in FIG. 4 as seen in the direction of the arrows, and illustrates a state where a rear detection portion 300 shown in FIG. 7 opposes a rear indicator portion 900 shown in FIG. 13.

[fig.17]FIG. 17 is a flowchart showing processing relating to printing of the tape printer 1.

[fig.18]FIG. 18 is a diagram showing a data structure of a color information table 520.

[fig.19]FIG. 19 is an external perspective view of a tape cassette 30 according to a modified example, as seen from the bottom surface side.

[fig.20]FIG. 20 is a bottom view of the tape cassette 30 according to the modified example, in which the rear indentation 68C is enlarged.

Description of Embodiments

[0053] Exemplary embodiments of the present invention will be explained below with reference to the figures. The configurations of the apparatuses, the flowcharts of

various processing and the like shown in the drawings are merely exemplary and do not intend to limit the present invention.

[0054] A tape printer 1 and a tape cassette 30 according to the present embodiment will be explained hereinafter with reference to FIG. 1 to FIG. 20. In the explanation of the present embodiment, the lower left side, the upper right side, the lower right side, and the upper left side in FIG. 1 are respectively defined as the front side, the rear side, the right side, and the left side of the tape printer 1. In addition, the lower right side, the upper left side, the upper right side, and the lower left side in FIG. 2 are respectively defined as the front side, the rear side, the right side, and the left side of the tape cassette 30.

[0055] Note that, in actuality, a group of gears, including gears 91, 93, 94, 97, 98 and 101 shown in FIG. 2, is covered and hidden by the bottom surface of a cavity 8A. However, for explanation purposes, the bottom surface of the cavity 8A is not shown in FIG. 2. Furthermore, in FIG. 2 to FIG. 6, side walls that form a periphery around a cassette housing portion 8 are shown schematically, but this is simply a schematic diagram, and the side walls shown in FIG. 2, for example, are depicted as thicker than they are in actuality. Moreover, in FIG. 3 to FIG. 6, for ease of understanding, the states in which various types of the tape cassette 30 are installed in the cassette housing portion 8 are shown with a top case 31A removed.

[0056] First, an outline configuration of the tape printer 1 according to the present embodiment will be explained. Hereinafter, the tape printer 1 configured as a general purpose device will be explained as an example. As the general purpose device, the tape printer 1 may commonly use a plurality of types of tape cassettes 30 with various types of tapes. The types of the tape cassettes 30 may include a thermal type tape cassette 30 that houses only a heat-sensitive paper tape, a receptor type tape cassette 30 that houses a print tape and an ink ribbon, and a laminated type tape cassette 30 that houses a double-sided adhesive tape, a film tape and an ink ribbon.

[0057] As shown in FIG. 1, the tape printer 1 is provided with a main unit cover 2 that has a rectangular shape in a plan view. A keyboard 3 is provided on the front side of the main unit cover 2. The keyboard 3 includes character keys for characters (letters, symbols, numerals, and so on), a variety of function keys, and so on. A display 5 is provided on the rear side of the keyboard 3. The display 5 displays input characters. A cassette cover 6 is provided on the rear side of the display 5. The cassette cover 6 may be opened and closed when the tape cassette 30 is replaced. Further, although not shown in the figures, a discharge slit is provided to the rear of the left side of the main unit cover 2, from which the printed tape is discharged to the outside. Also, a discharge window is formed on the left side of the cassette cover 6, such that, when the cassette cover 6 is in a closed state, the discharge slit is exposed to the outside.

- [0058] Next, an internal configuration within the main unit cover 2 below the cassette cover 6 will be explained with reference to FIG. 2 to FIG. 8. As shown in FIG. 2, the cassette housing portion 8 is provided in the interior of the main unit cover 2 below the cassette cover 6. The cassette housing portion 8 is an area in which the tape cassette 30 can be installed or removed. The cassette housing portion 8 includes a cavity 8A and a cassette support portion 8B. The cavity 8A is formed as a depression that has a flat bottom surface, and the shape of the cavity 8A generally corresponds to the shape of a bottom surface of a cassette case 31 (to be described later) when the tape cassette 30 is installed. The cassette support portion 8B is a flat portion extending horizontally from the outer edge of the cavity 8A.
- [0059] The plan view shape of the cassette support portion 8B generally corresponds to the plan view shape of the tape cassette 30, and is a rectangular shape that is longer in the left-and-right direction. The rear edge of the cavity 8A has a shape in which two arcs are lined up with each other in the left-and-right direction when seen in a plan view. A section of the cassette support portion 8B that is located between the two arcs is referred to as a rear support portion 8C. The rear support portion 8C is a portion that opposes a rear indentation 68C (refer to FIG. 11) of the tape cassette 30 installed in the cassette housing portion 8. The remaining part of the cassette support portion 8B except the rear support portion 8C is a portion that opposes a lower surface of a common portion 32 (more specifically, corner portions 32A to be described later) of the tape cassette 30 when the tape cassette 30 is installed in the cassette housing portion 8.
- [0060] A rear support pin 301 and a rear detection portion 300 are provided on the rear support portion 8C. The rear support pin 301 is a column-shaped member that protrudes upward from the rear support portion 8C, in the vicinity of a position where the two arcs are joined at the rear edge of the cavity 8A. The rear support pin 301 supports the rear indentation 68C of the tape cassette 30 (to be described later) from underneath when the tape cassette 30 is installed in the cassette housing portion 8.
- [0061] The rear detection portion 300 includes a plurality of detecting switches 310. Switch terminals 322 of the detecting switches 310 respectively protrude upward from through-holes 8D provided in the rear support portion 8C. In the present embodiment, the rear detection portion 300 includes five detecting switches 310A to 310E. Four of the detecting switches (the detecting switches 310A to 310D) are aligned in a single line along the rear end of the rear support portion 8C, in that order from the left side (the right side in FIG. 7). The remaining one detecting switch 310E is arranged to the front of the second detecting switch 310C from the right. Hereinafter, the detecting switches 310 provided in the rear detection portion 300 are referred to as the rear detecting switches 310.

- [0062] Here, the structure of the rear detecting switches 310 will be explained in detail with reference to FIG. 7. As shown in FIG. 7, each of the rear detecting switches 310 (the rear detecting switches 310A to 310E) includes a generally cylindrically shaped main unit 321 and a bar-shaped switch terminal 322. The main unit 321 is positioned below the rear support portion 8C, namely, inside the main unit cover 2. The switch terminal 322 can extend and retract in the direction of an axis line from one end of the main unit 321. The other end of the main unit 321 of each of the rear detecting switches 310 is attached to a switch support plate 320 and positioned inside the main unit cover 2.
- [0063] In addition, on the one end of the main units 321, the switch terminals 322 can extend and retract through the through-holes 8D formed in the rear support portion 8C. Each of the switch terminals 322 is constantly maintained in a state in which the switch terminal 322 extends from the main unit 321 due to a spring member (not shown in the figures) provided inside the main unit 321. When the switch terminal 322 is not pressed, the switch terminal 322 remains extended from the main unit 321 to be in an off state. On the other hand, when the switch terminal 322 is pressed, the switch terminal 322 is pushed back into the main unit 321 to be in an on state.
- [0064] As shown in FIG. 2, when the tape cassette 30 is not installed in the cassette housing portion 8, the rear detecting switches 310 are separated from the tape cassette 30. Consequently, all the rear detecting switches 310 are in the off state. On the other hand, when the tape cassette 30 is installed in the cassette housing portion 8, the rear detecting switches 310 oppose a rear indicator portion 900 (to be described later) of the tape cassette 30, and the rear detecting switches 310 are selectively pressed by the rear indicator portion 900. The type of the tape (hereinafter referred to as the tape type) mounted in the tape cassette 30 is detected based on a combination of the on and off states of the rear detecting switches 310. The detection of the tape type by the rear detection portion 300 will be described in more detail later.
- [0065] Further, as shown in FIG. 2, two positioning pins 102 and 103 are provided at two positions on the cassette support portion 8B. More specifically, the positioning pin 102 is provided on the left side of the cavity 8A and the positioning pin 103 is provided on the right side of the cavity 8A. The positioning pins 102 and 103 are provided at the positions that respectively oppose pin holes 62 and 63 (refer to FIG. 11), when the tape cassette 30 is installed in the cassette housing portion 8. The pin holes 62 and 63 are two indentations formed in the lower surface of the common portion 32 of the tape cassette 30. When the tape cassette 30 is installed in the cassette housing portion 8, the positioning pins 102 and 103 are respectively inserted into the pin holes 62 and 63 to support the tape cassette 30 from underneath at the left and right positions of the peripheral portion of the tape cassette 30.
- [0066] The cassette housing portion 8 is equipped with a feed mechanism, a print

mechanism, and the like. The feed mechanism pulls out the tape from the tape cassette 30 and feeds the tape. The print mechanism prints characters on a surface of the tape. As shown in FIG. 2, a head holder 74 is fixed in the front part of the cassette housing portion 8, and a thermal head 10 that includes a heating element (not shown in the figures) is mounted on the head holder 74.

[0067] A tape feed motor 23 that is a stepping motor is provided outside of the cassette housing portion 8 (the upper right side in FIG. 2). A drive gear 91 is anchored to the lower end of a drive shaft of the tape feed motor 23. The drive gear 91 is meshed with a gear 93 through an opening, and the gear 93 is meshed with a gear 94. A ribbon take-up shaft 95 is standing upward on the upper surface of the gear 94. The ribbon take-up shaft 95 drives the rotation of a ribbon take-up spool 44, which will be described later. In addition, the gear 94 is meshed with a gear 97, the gear 97 is meshed with a gear 98, and the gear 98 is meshed with a gear 101. A tape drive shaft 100 is standing upward on the upper surface of the gear 101. The tape drive shaft 100 drives the rotation of a tape drive roller 46, which will be described later.

[0068] If the tape feed motor 23 is driven to rotate in the counterclockwise direction in a state where the tape cassette 30 is installed in the cassette housing portion 8, the ribbon take-up shaft 95 is driven to rotate in the counterclockwise direction via the drive gear 91, the gear 93 and the gear 94. The ribbon take-up shaft 95 causes the ribbon take-up spool 44, which is fitted with the ribbon take-up shaft 95 by insertion, to rotate. Furthermore, the rotation of the gear 94 is transmitted to the tape drive shaft 100 via the gear 97, the gear 98 and the gear 101, to thereby drive the tape drive shaft 100 to rotate in the clockwise direction. The tape drive shaft 100 causes the tape drive roller 46, which is fitted with the tape drive shaft 100 by insertion, to rotate.

[0069] As shown in FIG. 3 to FIG. 6, on the front side of the head holder 74, an arm shaped platen holder 12 is pivotably supported around a support shaft 12A. A platen roller 15 and a movable feed roller 14 are both rotatably supported on the leading end of the platen holder 12. The platen roller 15 faces the thermal head 10, and may be moved close to and apart from the thermal head 10. The movable feed roller 14 faces the tape drive roller 46 that is fitted with the tape drive shaft 100 by insertion, and may be moved close to and apart from the tape drive roller 46.

[0070] A release lever (not shown in the figures), which moves in the left-and-right direction in response to the opening and closing of the cassette cover 6, is coupled to the platen holder 12. When the cassette cover 6 is opened, the release lever moves in the right direction, and the platen holder 12 moves toward the stand-by position shown in FIG. 3. At the stand-by position shown in FIG. 3, the platen holder 12 has moved away from the cassette housing portion 8. Therefore, the tape cassette 30 can be installed into or detached from the cassette housing portion 8 when the platen holder 12 is at the stand-

by position. The platen holder 12 is constantly elastically urged to remain in the stand-by position by a spiral spring that is not shown in the figures.

[0071] On the other hand, when the cassette cover 6 is closed, the release lever moves in the left direction and the platen holder 12 moves toward the print position shown in FIG. 4 to FIG. 6. At the print position shown in FIG. 4 to FIG. 6, the platen holder 12 has moved close to the cassette housing portion 8. As shown in FIG. 3 and FIG. 4, when the laminated type tape cassette 30 is installed in the cassette housing portion 8, the platen roller 15 presses the thermal head 10 via a film tape 59 and an ink ribbon 60. At the same time, the movable feed roller 14 presses the tape drive roller 46 via a double-sided adhesive tape 58 and the film tape 59.

[0072] In a similar way, as shown in FIG. 5, when the receptor type tape cassette 30 is installed in the cassette housing portion 8, the platen roller 15 presses the thermal head 10 via a print tape 57 and the ink ribbon 60, while the movable feed roller 14 presses the tape drive roller 46 via the print tape 57. Further, as shown in FIG. 6, when the thermal type tape cassette 30 is installed in the cassette housing portion 8, the platen roller 15 presses the thermal head 10 via a heat-sensitive paper tape 55, while the movable feed roller 14 presses the tape drive roller 46 via the heat-sensitive paper tape 55.

[0073] As described above, at the print position shown in FIG. 4 to FIG. 6, printing can be performed using the tape cassette 30 installed in the cassette housing portion 8. The heat-sensitive paper tape 55, the print tape 57, the double-sided adhesive tape 58, the film tape 59 and the ink ribbon 60 will be explained in more detail later.

[0074] As shown in FIG. 3, a feed path along which a printed tape 50 is fed extends from a tape discharge portion 49 of the tape cassette 30 to a discharge slit (not shown in the figures) of the tape printer 1. A cutting mechanism 17 that cuts the printed tape 50 at a predetermined position is provided on the feed path. The cutting mechanism 17 includes a fixed blade 18 and a movable blade 19 that opposes the fixed blade 18 and that is supported such that it can move in the back-and-forth direction (in the up-and-down direction in FIG. 3 to FIG. 6). The movable blade 19 is moved in the back-and-forth direction by a cutter motor 24 (refer to FIG. 9).

[0075] As shown in FIG. 3 to FIG. 6, an arm detection portion 200 is provided on the rear side surface of the platen holder 12, namely, a surface on the side that opposes the thermal head 10 (hereinafter referred to as a cassette-facing surface 12B). The arm detection portion 200 is provided slightly to the right of a center position in the longitudinal direction of the cassette-facing surface 12B. The arm detection portion 200 includes a plurality of detecting switches 210. Switch terminals 222 (refer to FIG. 15) of the detecting switches 210 respectively protrude to the rear such that the detecting switches 210 oppose the front wall (more specifically, an arm front wall 35 which will

be described later) of the tape cassette 30 installed in the cassette housing portion 8.

[0076] In a similar way to the above-described switch terminal 322, when the switch terminal 222 of each of the detecting switches 210 is not pressed, it is extended to be in an off state, and when the switch terminal 222 is pressed, it is pushed back to be in an on state. Note that, hereinafter, the detecting switches 210 provided in the arm detection portion 200 are referred to as the arm detecting switches 210.

[0077] As shown in FIG. 8, in the present embodiment, five through-holes 12C are formed in three rows in the vertical direction in the cassette-facing surface 12B of the platen holder 12. More specifically, the through-holes 12C are arranged such that two holes are arranged in an upper row, two holes are arranged in a middle row and one hole is arranged in a lower row. Positions of the through-holes 12C are different from each other in the left-and-right direction. Specifically, the five through-holes 12C are arranged in a zigzag pattern from the left side of the cassette-facing surface 12B (the right side in FIG. 8), in the following order: the left side of the middle row, the left side of the upper row, the right side of the middle row, the right side of the upper row, and then the lower row. The five arm detecting switches 210 are provided from the left side of the cassette-facing surface 12B in the order 210A, 210B, 210C, 210D, and 210E, at positions corresponding to the five through-holes 12C. The arm detecting switches 210A to 210E are each positioned at a height facing an arm indicator portion 800 (to be described later), in a state where the tape cassette 30 is installed in the cassette housing portion 8 at the proper position.

[0078] If the platen holder 12 moves toward the stand-by position (refer to FIG. 3) in a state where the tape cassette 30 is installed in the cassette housing portion 8, the arm detecting switches 210 are separated from the tape cassette 30. Consequently, all the arm detecting switches 210 are in the off state. On the other hand, if the platen holder 12 moves toward the print position (refer to FIG. 4 to FIG. 6), the arm detecting switches 210 oppose the front wall (more specifically, the arm front wall 35 that will be described later) of the tape cassette 30, and the arm detecting switches 210 are selectively pressed by the arm indicator portion 800, which will be described later. The tape type is detected based on a combination of the on and off states of the arm detecting switches 210, as will be described in more detail later.

[0079] Further, as shown in FIG. 3 to FIG. 6, a latching piece 225 is provided on the cassette-facing surface 12B of the platen holder 12. The latching piece 225 is a plate-like protrusion that extends in the left-and-right direction. In a similar way to the switch terminals 222 of the arm detecting switches 210, the latching piece 225 protrudes from the cassette-facing surface 12B in a generally horizontal manner toward the cassette housing portion 8. In other words, the latching piece 225 protrudes such that the latching piece 225 opposes the front wall (more specifically, the arm front wall

35) of the tape cassette 30 installed in the cassette housing portion 8. When the tape cassette 30 is installed in the cassette housing portion 8 at the proper position, the latching piece 225 is positioned at a height facing a latching hole 820 (refer to FIG. 2) formed in the arm front wall 35 of the tape cassette 30.

[0080] Next, the electrical configuration of the tape printer 1 will be explained with reference to FIG. 9. As shown in FIG. 9, the tape printer 1 includes a control circuit 400 formed on a control board. The control circuit 400 includes a CPU 401 that controls each instrument, a ROM 402, a CGROM 403, a RAM 404, and an input/output interface 411, all of which are connected to the CPU 401 via a data bus 410.

[0081] The ROM 402 stores various programs to control the tape printer 1, including a display drive control program, a print drive control program, a pulse number determination program, a cutting drive control program, and so on. The display drive control program controls a liquid crystal drive circuit (LCDC) 405 in association with code data of characters, such as letters, numerals and so on input from the keyboard 3. The print drive control program drives the thermal head 10 and the tape feed motor 23. The pulse number determination program determines the number of pulses to be applied corresponding to the amount of formation energy for each print dot. The cutting drive control program drives the cutter motor 24 to cut the printed tape 50 at a predetermined cutting position. The CPU 401 performs a variety of computations in accordance with each type of program. Note that the ROM 402 also stores various tables that are used to identify the tape type of the tape cassette 30 installed in the tape printer 1. The tables will be explained in more detail later.

[0082] The CGROM 403 stores print dot pattern data to be used to print various characters. The print dot pattern data is associated with corresponding code data for the characters. The print dot pattern data is categorized by font (Gothic, Mincho, and so on), and the stored data for each font includes six print character sizes (dot sizes of 16, 24, 32, 48, 64 and 96, for example).

[0083] The RAM 404 includes a plurality of storage areas, including a text memory, a print buffer and so on. The text memory stores text data input from the keyboard 3. The print buffer stores dot pattern data, including the printing dot patterns for characters and the number of pulses to be applied that is the amount of formation energy for each dot, and so on. The thermal head 10 performs dot printing in accordance with the dot pattern data stored in the print buffer. Other storage areas store data obtained in various computations and so on.

[0084] The input/output interface 411 is connected, respectively, to the arm detecting switches 210A to 210E, the rear detecting switches 310A to 310E, the keyboard 3, the liquid crystal drive circuit (LCDC) 405 that has a video RAM (not shown in the figures) to output display data to the display (LCD) 5, a drive circuit 406 that drives

the thermal head 10, a drive circuit 407 that drives the tape feed motor 23, a drive circuit 408 that drives the cutter motor 24, and so on.

- [0085] The configuration of the tape cassette 30 according to the present embodiment will be explained below with reference to FIG. 2 to FIG. 6 and FIG. 10 to FIG. 16. Hereinafter, the tape cassette 30 configured as a general purpose cassette will be explained as an example. As the general purpose cassette, the tape cassette 30 may be assembled as the thermal type, the receptor type and the laminated type that have been explained above, by changing, as appropriate, the type of the tape to be mounted in the tape cassette 30 and by changing the presence or absence of the ink ribbon, and so on.
- [0086] FIG. 2 to FIG. 4 and FIG. 10 to FIG. 14 are figures relating to the tape cassette 30 in which a width of the tape is 36 mm, which is equal to or greater than a predetermined width (18mm, for example). The tape cassette 30 represented in FIG. 2 to FIG. 4 and FIG. 10 to FIG. 14 is assembled as the laminated type cassette in which the double-sided adhesive tape 58 with a white base material, and the ink ribbon 60 with a black ink color are mounted.
- [0087] As shown in FIG. 2 and FIG. 10, the tape cassette 30 includes a cassette case 31 that is a housing having a generally rectangular parallelepiped shape (box-like shape), with rounded corner portions in a plan view. The cassette case 31 includes a bottom case 31B and a top case 31A. The bottom case 31B includes a bottom wall 30B that forms the bottom surface of the cassette case 31. The top case 31A includes a top wall 30A that forms the top surface of the cassette case 31. The top case 31A is fixed to an upper portion of the bottom case 31B.
- [0088] When the top case 31A and the bottom case 31B are joined, a side wall 30C of a predetermined height is formed. The side wall 30C extends between the top wall 30A and the bottom wall 30B along the peripheries of the top wall 30A and the bottom wall 30B. In other words, the cassette case 31 is a box-shaped case that has the top wall 30A and the bottom wall 30B, which are a pair of rectangular flat portions opposing each other in a vertical direction, and the side wall 30C (in the present embodiment, including four side walls of a front wall, a rear wall, a left side wall and a right side wall) that has a predetermined height and extends along the peripheries of the top wall 30A and the bottom wall 30B.
- [0089] In the cassette case 31, the peripheries of the top wall 30A and the bottom wall 30B may not be entirely surrounded by the side wall 30C. A part of the side wall 30C (the rear wall, for example) may have an aperture that exposes the interior of the cassette case 31 to the outside. Further, a boss that connects the top wall 30A and the bottom wall 30B may be provided in a position facing the aperture. In the explanation below, the distance from the bottom surface to the top surface (the length in the vertical direction) is referred to as the height of the tape cassette 30 or the height of the cassette

case 31. In the present embodiment, the vertical direction of the cassette case 31 (namely, the direction in which the top wall 30A and the bottom wall 30B oppose each other) generally corresponds to the direction of installation and removal of the tape cassette 30.

[0090] The cassette case 31 has the corner portions 32A that have the same width (the same length in the vertical direction), regardless of the type of the tape cassette 30. The corner portions 32A each protrude in an outward direction to form a right angle when seen in a plan view. However, the front left corner portion 32A does not form a right angle in the plan view, as the tape discharge portion 49 is provided in the corner. When the tape cassette 30 is installed in the cassette housing portion 8, the lower surface of the corner portions 32A opposes the above-described cassette support portion 8B inside the cassette housing portion 8.

[0091] The cassette case 31 includes a portion that is called the common portion 32. The common portion 32 includes the corner portions 32A and encircles the cassette case 31 along the side wall 30C at the same position as the corner portions 32A in the vertical (height) direction of the cassette case 31 and also has the same width as the corner portions 32A. More specifically, the common portion 32 is a portion that has a symmetrical shape in the vertical direction with respect to a center line in the vertical (height) direction of the cassette case 31.

[0092] The height of the tape cassette 30 differs depending on the width of the tape (the heat-sensitive paper tape 55, the print tape 57, the double-sided adhesive tape 58, the film tape 59 and so on) mounted in the cassette case 31. The height of the common portion 32, however, is set to be the same, regardless of the width of the tape of the tape cassette 30. For example, when the width of the common portion 32 is 12mm, as the width of the tape of the tape cassette 30 is larger (18mm, 24mm, 36mm, for example), the height of the cassette case 31 becomes accordingly larger, but the width of the common portion 32 remains constant.

[0093] As shown in FIG. 2, FIG. 10 and FIG. 11, the top case 31A and the bottom case 31B respectively have support holes 65A, 66A and 67A and support holes 65B, 66B and 67B that rotatably support a first tape spool 40, a second tape spool 41 and the ribbon take-up spool 44, respectively, which will be explained later. The support holes 65A and 65B are communicated with a first tape housing area 33A (refer to FIG. 3 to FIG. 6) at a substantially center position of the first tape housing area 33A when seen in a plan view. The first tape housing area 33A is provided in a left side area inside the cassette case 31. The support holes 66A and 66B are communicated with a second tape housing area 33B (refer to FIG. 3 to FIG. 6) at a substantially center position of the second tape housing area 33B when seen in a plan view. The second tape housing area 33B is provided in a right side area inside the cassette case 31.

- [0094] The first tape housing area 33A has a generally circular shape in a plan view that corresponds to the tape wound on the first tape spool 40 (the double-sided adhesive tape 58 in FIG. 3 and FIG. 4). The second tape housing area 33B has a generally circular shape in a plan view that corresponds to the tape wound on the second tape spool 41 (the film tape 59 in FIG. 3 and FIG. 4). The first and second tape housing areas 33A and 33B are provided in the cassette case 31 whose longitudinal direction is the left-and-right direction, and lined up with each other in the left-and-right direction such that their outer edges are adjoined to each other in a plan view. Further, the front right portion in the cassette case 31 is provided with an ink ribbon housing area 33C that is positioned to the front of the first and second tape housing areas 33A and 33B.
- [0095] In the laminated type tape cassette 30 shown in FIG. 3 and FIG. 4, the double-sided adhesive tape 58 wound on the first tape spool 40, the film tape 59 wound on the second tape spool 41 and the ink ribbon 60 wound on a ribbon spool 42 are mounted in the cassette case 31. The first tape spool 40, on which the double-sided adhesive tape 58 is wound with its release paper facing outward, is rotatably mounted in the first tape housing area 33A via the support holes 65A and 65B. The second tape spool 41, on which the film tape 59 is wound, is rotatably mounted in the second tape housing area 33B via the support holes 66A and 66B. The ink ribbon 60 that is wound on the ribbon spool 42 is rotatably arranged in the ink ribbon housing area 33C.
- [0096] Between the first tape spool 40 and the ribbon spool 42 in the cassette case 31, the ribbon take-up spool 44 is rotatably supported by the support holes 67A and 67B. The ribbon take-up spool 44 pulls out the ink ribbon 60 from the ribbon spool 42 and takes up the ink ribbon 60 that has been used to print characters. A clutch spring (not shown in the figures) is attached to a lower portion of the ribbon take-up spool 44 to prevent loosening of the taken up ink ribbon 60 due to reverse rotation of the ribbon take-up spool 44.
- [0097] In the receptor type tape cassette 30 shown in FIG. 5, the print tape 57 wound on the first tape spool 40 and the ink ribbon 60 wound on the ribbon spool 42 are mounted in the cassette case 31. The receptor type tape cassette 30 does not include the second tape spool 41.
- [0098] In the thermal type tape cassette 30 shown in FIG. 6, the heat-sensitive paper tape 55 wound on the first tape spool 40 is mounted in the cassette case 31. The thermal type tape cassette 30 does not include the second tape spool 41 and the ribbon spool 42.
- [0099] As shown in FIG. 2, a semi-circular groove 34K that has a semi-circular shape in a plan view is provided in the front wall of the cassette case 31, and extends over the height of the cassette case 31 (in other words, extends from the top surface to the bottom surface). Of the front wall of the cassette case 31, a section that stretches leftwards from the semi-circular groove 34K is referred to as the arm front wall 35. A

portion that is defined by the arm front wall 35 and an arm rear wall 37 and that extends leftwards from the front right portion of the tape cassette 30 is referred to as an arm portion 34. The arm rear wall 37 is a wall separately provided at the rear of the arm front wall 35 and extends over the height of the cassette case 31.

- [0100] As shown in FIG. 12, a tape feed path, along which the film tape 59 is fed, and a ribbon feed path, along which the ink ribbon 60 is fed, are formed as different feed paths separated by a separating wall 34D inside the arm portion 34. After the film tape 59 and the ink ribbon 60 are respectively guided and fed along the feed paths, the film tape 59 and the ink ribbon 60 are joined together at an exit 34A of the arm portion 34, and are discharged from the exit 34A toward a head insertion portion 39.
- [0101] Although FIG. 12 shows an example of the laminated type tape cassette 30 (refer to FIG. 3 and FIG. 4), the arm portion 34 of the other types of tape cassettes 30 is similar. In the receptor type tape cassette 30 (refer to FIG. 5), the print tape 57 is guided and fed along the tape feed path, while the ink ribbon 60 is guided and fed along the ribbon feed path. In the thermal type tape cassette 30 (refer to FIG. 6), the heat-sensitive paper tape 55 is guided and fed along the tape feed path, while the ribbon feed path is not used.
- [0102] When the platen holder 12 moves to the print position (refer to FIG. 4 to FIG. 6) in a state where the tape cassette 30 is installed in the cassette housing portion 8, the arm detection portion 200 and the latching piece 225 provided on the cassette-facing surface 12B oppose the arm front wall 35. As shown in FIG. 2 and FIG. 12, the arm front wall 35 is provided with the arm indicator portion 800 and the latching hole 820. The arm indicator portion 800 allows the tape printer 1 to detect the tape type, by selectively pressing the arm detecting switches 210. The latching hole 820 is a hole into which the latching piece 225 is inserted.
- [0103] The arm indicator portion 800 includes a plurality of indicators. Each of the indicators is formed as one of the non-pressing portion 801 and the pressing portion 802 and provided at a position corresponding to each of the arm detecting switches 210. Specifically, the arm indicator portion 800 includes a combination of the non-pressing portion(s) 801 and the pressing portion(s) 802 arranged in a pattern that corresponds to print information. The print information, among the tape types of the tape cassette 30, is essential to perform correct printing in the tape printer 1. In the present embodiment, the arm indicator portion 800 includes five indicators 800A to 800E, each of which is formed as either the non-pressing portion 801 or the pressing portion 802, arranged at positions that respectively oppose the five arm detecting switches 210A to 210E when the tape cassette 30 is installed in the cassette housing portion 8.
- [0104] The non-pressing portion 801 is a switch hole that has an upright rectangular shape in a front view. The switch terminal 222 (refer to FIG. 17) of each of the arm detecting

switches 210 can be inserted into and removed from the switch hole. The arm detecting switch 210 that opposes the non-pressing portion 801 remains in the off state, because the switch terminal 222 is inserted into the non-pressing portion 801. The pressing portion 802 is a surface portion that does not allow the insertion of the switch terminal 222. The arm detecting switch 210 that opposes the pressing portion 802 is changed to the on state, because the switch terminal 222 contacts with the pressing portion 802.

[0105] The latching hole 820 is a slit-like through-hole that extends in the left-and-right direction on the upper right side of the arm indicator portion 800. The latching hole 820 is arranged to oppose the latching piece 225 (refer to FIG. 8) such that the latching piece 225 can be inserted into and removed from the latching hole 820 when the tape cassette 30 is installed in the cassette housing portion 8.

[0106] As shown in FIG. 2 to FIG. 6, the head insertion portion 39 is a space that has a generally rectangular shape in a plan view and that extends through the tape cassette 30 in the vertical direction. The head insertion portion 39 is surrounded by the arm rear wall 37 and a peripheral wall that is provided continuously from the arm rear wall 37. The head holder 74 that supports the thermal head 10 of the tape printer 1 is inserted into the head insertion portion 39, and the thermal head 10 performs printing on the tape (one of the heat-sensitive paper tape 55, the print tape 57 and the film tape 59) discharged from the exit 34A of the arm portion 34.

[0107] Further, a support hole 64 (refer to FIG. 11) is provided on the downstream side of the head insertion portion 39, in the tape feed direction from the exit 34A of the arm portion 34 to the tape discharge portion 49. The tape drive roller 46 is rotatably supported inside the support hole 64. In a case where the laminated type tape cassette 30 shown in FIG. 3 and FIG. 4 is installed in the cassette housing portion 8, the tape drive roller 46, by moving in concert with the opposing movable feed roller 14, pulls out the film tape 59 from the second tape spool 41. At the same time, the tape drive roller 46 pulls out the double-sided adhesive tape 58 from the first tape spool 40, then guides the double-sided adhesive tape 58 to the print surface of the film tape 59 to bond them together.

[0108] A pair of regulating members 36 that match in the vertical direction are provided on the upstream side of the tape drive roller 46. The base portions of the regulating members 36 regulate the printed film tape 59 in the vertical direction (in the tape width direction) on the downstream side of the thermal head 10, and direct the printed film tape 59 toward the tape discharge portion 49. The regulating members 36 regulate the film tape 59 such that it can be bonded to the double-sided adhesive tape 58 appropriately without making any positional displacement.

[0109] A guide wall 47 is standing in the vicinity of the regulating members 36. The guide wall 47 serves to separate the used ink ribbon 60 that has been fed via the head

insertion portion 39 from the film tape 59, and guides the used ink ribbon 60 toward the ribbon take-up spool 44. A separating wall 48 is standing between the guide wall 47 and the ribbon take-up spool 44. The separating wall 48 prevents mutual contact between the used ink ribbon 60 that is guided along the guide wall 47 and the double-sided adhesive tape 58 that is wound on and supported by the first tape spool 40.

[0110] In a case where the receptor type tape cassette 30 shown in FIG. 5 is installed in the cassette housing portion 8, the print tape 57 is pulled out from the first tape spool 40 by the tape drive roller 46 moving in concert with the movable feed roller 14. On the downstream side of the thermal head 10, the printed print tape 57 is regulated in the vertical direction (in the tape width direction) by the base portions of the regulating members 36, and is guided toward the tape discharge portion 49. In addition, the used ink ribbon 60 that has been fed via the head insertion portion 39 is separated from the print tape 57 by the guide wall 47, and guided toward the ribbon take-up spool 44.

[0111] In a case where the thermal type tape cassette 30 shown in FIG. 6 is installed, the heat-sensitive paper tape 55 is pulled out from the first tape spool 40 by the tape drive roller 46 moving in concert with the movable feed roller 14. On the downstream side of the thermal head 10, the printed heat-sensitive paper tape 55 is regulated in the vertical direction (in the tape width direction) by the base portions of the regulating members 36, and guided toward the tape discharge portion 49.

[0112] As shown in FIG. 11, the pin holes 62 and 63 are provided at two positions on the lower surface of the corner portions 32A, corresponding to the above-described positioning pins 102 and 103 of the tape printer 1. More specifically, the pin hole 62, into which the positioning pin 102 is inserted, is an indentation provided in the lower surface of the corner portion 32A to the rear (the upper side in FIG. 11) of the support hole 64 that is provided in the left front portion of the cassette case 31 (the lower right side in FIG. 11). The pin hole 63, into which the positioning pin 103 is inserted, is an indentation provided in the lower surface of the corner portion 32A in the vicinity of a central portion of the right end of the cassette case 31 (the left side in FIG. 11). Note that the tape drive roller 46 and some other components are not shown in FIG. 11.

[0113] A distance in the vertical (height) direction of the tape cassette 30 between the position of the pin holes 62 and 63 and a center position in the vertical direction of the film tape 59 that is the print medium housed in the cassette case 31 is constant, regardless of the tape type (the tape width, for example) of the tape cassette 30. In other words, the distance remains constant even when the height of the tape cassette 30 is different.

[0114] As shown in FIG. 2 and FIG. 10, a top surface affixing portion 68A, a rear surface affixing portion 68B and the rear indentation 68C are provided on a rear surface 68 of the cassette case 31. The top surface affixing portion 68A is provided in a rear portion

of the top wall 30A, and has a rectangular shape in a plan view. The back surface affixing portion 68B is provided along the vertical direction of the side wall 30C, and has a rectangular shape in a rear view. The rear indentation 68C is provided in a rear portion of the bottom wall 30B, and has a generally triangular shape in a bottom view. The top surface affixing portion 68A, the back surface affixing portion 68B and the rear indentation 68C have the same width, and are provided at a substantially center position in the left-and-right direction in a rear portion of the cassette case 31. The top surface affixing portion 68A, the back surface affixing portion 68B and the rear indentation 68C form an area that extend continuously over three surfaces of the top wall 30A, the side wall 30C and the bottom wall 30B.

[0115] The top surface affixing portion 68A and the back surface affixing portion 68B are parts onto which a label sheet (not shown in the figures) to indicate the tape type etc. of the tape cassette 30 is affixed over two surfaces of the top wall 30A and the side wall 30C (specifically, a rear wall). The rear indentation 68C is a stepped portion that is formed between the first tape housing area 33A and the second tape housing area 33B (refer to FIG. 3 to FIG. 6 and FIG. 14) in the rear portion of the cassette case 31. In other words, the rear indentation 68C is provided between a rear wall 31C (refer to FIG. 13 and FIG. 14) and the first and second tape housing areas 33A and 33B. The rear wall 31C is a wall portion forming the rear surface, of the side wall 30C of the tape cassette 30.

[0116] As shown in FIG. 10 and FIG. 11, the rear indentation 68C is a flat portion that is upwardly indented in the bottom wall 30B, and has a shape that substantially matches the shape of the rear support portion 8C shown in FIG. 2. The rear indentation 68C is located at a slightly higher position than the lower surface 32B of the corner portions 32A. As described earlier, the common portion 32 is formed symmetrically in the vertical direction with respect to the center line in the vertical (height) direction of the cassette case 31, and the height T of the common portion 32 is set to be the same, regardless of the width of the tape of the tape cassette 30. Therefore, similarly to the common portion 32, the distance from the center line in the vertical (height) direction of the cassette case 31 to the rear indentation 68C is the same, regardless of the width of the tape of the tape cassette 30.

[0117] More specifically, the bottom surface formed by the bottom wall 30B includes the lower surface 32B and the rear indentation 68C, in addition to a lower end surface portion. The lower end surface portion is a flat portion that is located at the lower end of the cassette case 31 and occupies a major part of the bottom surface. The lower surface 32B and the rear indentation 68C are both flat portions extending parallel to the lower end surface portion. Of the bottom surface of the cassette case 31, the lower surface 32B is located at a higher position than the lower end surface portion, and the

rear indentation 68C is located at a higher position than the lower surface 32B. In other words, these surface portions are located at different height positions. As described above, the lower surface 32B and the rear indentation 68C are respectively located at fixed positions in the vertical (height) direction of the cassette case 31, regardless of the tape width of the tape cassette 30.

[0118] When the tape cassette 30 is installed in the cassette housing portion 8 at a proper position, the rear support pin 301 provided in the rear support portion 8C contacts with the rear indentation 68C, and the rear detection portion 300 opposes the rear indentation 68C. Therefore, the rear indentation 68C is provided with the rear indicator portion 900 that is a portion that makes it possible for a person to identify the tape type, and that also allows the tape printer 1 to detect the tape type by selectively pressing the rear detecting switches 310 (refer to FIG. 2 and FIG. 7).

[0119] A pair of corner portions adjacent to the first and second tape housing areas 33A and 33B on the rear edge side of the cassette case 31 is a pair of corner portions 32A. The corner portions 32A each include the lower surface 32B. The rear indicator portion 900 is provided in the rear indentation 68C that is located between the pair of corner portions 32A. Protrusions, which will be described later, protrude downward from the rear indentation 68C. With this configuration, the rear indicator portion 900 allows a person and the tape printer 1 to identify the tape type.

[0120] The structure and the function of the rear indentation 68C that includes the rear indicator portion 900 will be explained below in detail with reference to FIG. 13 and FIG. 14.

[0121] As described above, the tape cassette 30 according to the present embodiment is structured such that when a person looks at the tape cassette 30 alone in a state in which the tape cassette 30 is not installed in the tape printer 1, the person can identify the type of the tape by visually checking the rear indicator portion 900. In addition, the tape cassette 30 is structured such that when the tape cassette 30 is installed in the cassette housing portion 8 of the tape printer 1, the tape printer 1 can identify the type of the tape by the rear detection portion 300 detecting information indicated by the rear indicator portion 900. In the present embodiment, the tape type indicated by the rear indicator portion 900 is color information relating to the tape mounted in the tape cassette 30. First, an area included in the rear indentation 68C and the structure within the area will be explained.

[0122] As shown in FIG. 13, the rear indentation 68C includes a specified area R0. The specified area R0 is an area extending to the front from the rear wall 31C, which is the wall portion forming the rear surface, of the side surface 30C of the tape cassette 30. More specifically, the specified area R0 is an area adjoining the rear wall 31C in the rear indentation 68C. In the present embodiment, the entire rear indentation 68C is the

specified area R0. The specified area R0 includes a plurality of vertical information sections X and a plurality of lateral information sections Y. The plurality of vertical information sections X is formed as a plurality of strip-shaped sections extending along a front-rear direction (the up-and-down direction in FIG. 13), which is a short side direction of the cassette case 31. The plurality of lateral information sections Y is formed as a plurality of strip-shaped sections extending along a left-and-right direction (the left-and-right direction in FIG. 13), which is a long side direction of the cassette case 31.

[0123] The vertical information sections X according to the present embodiment that are exemplified in FIG. 13 include four vertical information sections X1 to X4. The vertical information sections X1 to X4 are arranged at equal intervals in the left-and-right direction of the cassette case 31. Among the vertical information sections X1 to X4, the vertical information section X1 is positioned on the leftmost side (the right side in FIG. 13). The vertical information sections X2, X3 and X4 are arranged in that order from the vertical information section X1 toward the right side (the left side in FIG. 13). The widths (namely, the lengths in the left-and-right direction) of the vertical information sections X1 to X4 are approximately the same, and adjacent vertical information sections among the vertical information sections X1 to X4 are adjacent to each other at equal intervals.

[0124] The vertical information section X3 includes a part (i.e., a contact point P shown in FIG. 3 to FIG. 6) at which outer peripheral edges of the first and second tape housing areas 33A and 33B contact each other when seen in a plan view. In other words, the vertical information section X3 includes an imaginary line (hereinafter referred to as a reference line Z) that passes through the contact point P and that extends in the front-rear direction. In the vertical information section X3 according to the present embodiment, the reference line Z is positioned slightly to the left (to the right in FIG. 13) of a substantially center position in the left-and-right direction of the vertical information section X3.

[0125] The lateral information sections Y according to the present embodiment that are exemplified in FIG. 13 include two lateral information sections Y1 and Y2. The lateral information sections Y1 and Y2 are arranged in rows in the front-rear direction (the up-and-down direction in FIG. 13) of the cassette case 31. The lateral information section Y1 adjoins the rear wall 31C, in the specified area R0. The lateral information section Y2 is provided to the front (the lower side in FIG. 13) of the lateral information section Y1, in the specified area R0. The widths (namely, the lengths in the front-rear direction) of the lateral information sections Y1 and Y2 are approximately the same.

[0126] The specified area R0 is an area that opposes the rear detecting switches 310 of the tape printer 1 when the tape cassette 30 is installed in the cassette housing portion 8,

and includes the rear indicator portion 900 that indicates the tape type (color information, in the present embodiment) of the tape cassette 30. At least one protrusion is formed in at least one of the lateral information sections Y1 and Y2. A pattern in which the at least one protrusion is formed in the lateral information sections Y1 and Y2 are determined in advance, according to the color information. The rear indicator portion 900 is a portion that indicates the color information by a combination of whether or not a protrusion is formed in each of the lateral information sections Y1 and Y2. A person can recognize the color information by visually checking the combination of the protrusion (s) formed in the lateral information sections Y1 and Y2 of the rear indicator portion 900.

[0127] The left-and-right direction positions of the protrusions formed in the lateral information sections Y1 and Y2 may be fixed for each of the lateral information sections Y1 and Y2. For example, among a plurality of areas where the lateral information sections Y1, Y2 and the vertical information sections X1 to X4 intersect and overlap with each other (hereinafter referred to as overlapping areas), at least one overlapping area in each of the lateral information sections Y1 and Y2 may be fixed as an indicator. In such a case, the color information may be identified based on a combination of whether or not the protrusion is formed in each of the indicators. If positions corresponding to the rear detecting switches 310 (refer to FIG. 2 and FIG. 7) of the tape printer 1 are determined as the indicators, the color information can be identified not only by human visual check but also by the tape printer 1.

[0128] Given this, in the present embodiment, five overlapping areas that respectively oppose the five rear detecting switches 310A to 310E shown in FIG. 2 and FIG. 7 when the tape cassette 30 is installed in the cassette housing portion 8 are fixed as indicators 900A to 900E. More specifically, as shown in FIG. 13, the area in which the lateral information section Y1 and the vertical information section X1 intersect and overlap with each other functions as the indicator 900A that opposes the rear detecting switch 310A. The area in which the lateral information section Y1 and the vertical information section X2 intersect and overlap with each other functions as the indicator 900B that opposes the rear detecting switch 310B. The area in which the lateral information section Y1 and the vertical information section X3 intersect and overlap with each other functions as the indicator 900C that opposes the rear detecting switch 310C. The area in which the lateral information section Y1 and the vertical information section X4 intersect and overlap with each other functions as the indicator 900D that opposes the rear detecting switch 310D. The area in which the lateral information section Y2 and the vertical information section X3 intersect and overlap with each other functions as the indicator 900E that opposes the rear detecting switch 310E.

[0129] In the example shown in FIG. 13, the protrusions are formed in the indicators 900B

and 900C. On the other hand, the indicators 900A, 900D and 900E are surface portions that are in the same plane as the rear indentation 68C, and no protrusion is formed therein. In such a manner, each of the indicators 900A to 900E is formed as either a protrusion or a surface portion. The protrusion and the surface portion can be identified by human visual check. In addition, when the protrusion and the surface portion oppose the rear detecting switches 310, the protrusion and the surface portion respectively function as a pressing portion 902 that presses the rear detecting switch 310 and as a non-pressing portion 901 that does not press the rear detecting switch 310. Thus, the protrusion and the surface portion allow the tape printer 1 to identify the color information. The relationship between the indicators 900A to 900E and the rear detecting switches 310 will be described later in detail.

[0130] In the present embodiment, one indicator is provided in each of the vertical information sections X1, X2 and X4, while a plurality of indicators are provided in the vertical information section X3. This is because the specified area R0 is the rear indentation 68C that has a generally triangular shape in a plan view and that is defined by the first and second tape housing areas 33A and 33B and the rear wall 31C, and the rear indentation 68C has the maximum length in the front-rear direction, on the above-described reference line Z. In other words, among the vertical information sections X1 to X4, the vertical information section X3 including the reference line Z has the maximum length in the front-rear direction. Accordingly, in a case where a plurality of indicators are arranged in rows in the front-rear direction in the rear indentation 68C, it may be most favorable to provide the plurality of indicators in the vertical information section X3, as described above.

[0131] With the above-described structure, in the tape cassette 30 according to the present embodiment, a person can easily recognize which of the lateral information sections Y1 and Y2, or which of the indicators 900A to 900E includes an indicator element (a protrusion or a surface portion). Hereinafter, this reason will be explained with reference to FIG. 13 and FIG. 14.

[0132] If a person can ascertain which of the respective lateral information sections Y1 and Y2 includes a protrusion by visually checking the rear indentation 68C, the person can identify the color information of the tape cassette 30 simply by visually checking the combination of the protrusions in the respective lateral information sections Y1 and Y2. The person may visually check the rear indentation 68C in either of the following two patterns. The first pattern is that the person looks at the tape cassette 30 in a plan view with the top case 31A removed, and visually checks the rear indentation 68C from above. The second pattern is that the person looks at the tape cassette 30 in a bottom view (from underneath), and visually checks the rear indentation 68C.

[0133] As shown in FIG. 14, when a person visually checks the rear indentation 68C of the

tape cassette 30 from above (namely, from the inner side of the bottom case 31B) with the top case 31A removed, the person may not be able to directly see the pattern in which the protrusion(s) is formed in the rear indicator portion 900. On the other hand, as shown in FIG. 13, when the person visually checks the rear indentation 68C from underneath (namely, from the outer side of the bottom case 31B), the person can directly see the pattern in which the protrusion(s) is formed in the rear indicator portion 900. Accordingly, even when the person does not know the positions of the lateral information sections Y1 and Y2, the person can identify the elements in the lateral information sections Y1 and Y2 using the following methods.

[0134] First, element identification of the lateral information section Y1 will be explained. As shown in FIG. 14, when a person visually checks the rear indentation 68C from above, the person can identify, as the lateral information section Y1, an area adjoining the rear wall 31C and extending in the left-and-right direction in a plan view. On the other hand, as shown in FIG. 13, when the person visually checks the rear indentation 68C from underneath, the person cannot directly see the rear wall 31C. However, because the rear wall 31C is a thin plate and its thickness (the length in the front-rear direction) is small, the position in the front-rear direction of the rear wall 31C generally corresponds to the position in the front-rear direction of the contour formed by the rear surface when the tape cassette 30 is seen in a bottom view. Therefore, the person can identify, as the lateral information section Y1, the area adjacent to the contour formed by the rear surface and extending in the left-and-right direction in a bottom view.

[0135] Thus, the person can identify a protrusion formed adjacent to the rear wall 31C as a protrusion formed in the lateral information section Y1. Further, the person can identify a part where the protrusion is not formed within the area adjacent to the rear wall 31C, as a surface portion provided in the lateral information section Y1.

[0136] Next, element identification of the lateral information section Y2 will be explained. In the rear indicator portion 900 according to the present embodiment, a protrusion(s) and a surface portion(s) are provided in a pattern that is determined in advance in accordance with the color information. In the present embodiment, in certain patterns that correspond to certain color information (for example, the tape color: clear, the character color: black) relating to major tapes, a pattern of the two indicators that are respectively provided in the lateral information sections Y1 and Y2 and that are arranged in rows in the front-rear direction is fixed. Specifically, for the major color information, the front indicator is provided with a surface portion, and the rear indicator is provided with a protrusion. Note that the major tape refers to a tape that has high likelihood of being mounted in the tape cassette 30. For example, in the examples shown in FIG. 13 and FIG. 14, the two indicators 900C and 900E, through which the

reference line Z passes, are formed as a combination of a protrusion and a surface portion, respectively.

[0137] With this arrangement, when the rear indentation 68C is visually checked from underneath, with most of the tape cassettes 30 including the major tape, it is ensured that, of the two indicators aligned in the front-rear direction, the indicator formed as a protrusion is provided adjacent to the rear wall 31C and to the rear of the indicator formed as a surface portion. Therefore, the surface portion in the lateral information section Y2 does not adjoin the rear wall 31C (the contour of the rear surface in the bottom view). In other words, the surface portion that is located to the front of the protrusion adjoining the rear wall 31C can be identified as the surface portion of the indicator 900E provided in the lateral information section Y2. Therefore, a person can identify the position of the lateral information section Y1 by visually checking the protrusion of the indicator 900C, and the person can also identify the position of the lateral information section Y2 by visually checking the surface portion of the indicator 900E.

[0138] On the contrary, of the two indicators that are respectively provided in the lateral information sections Y1 and Y2 and that are aligned in the front-rear direction, the rear indicator may be formed as a surface portion and the front indicator may be formed as a protrusion. For example, although not shown in the figures, the two indicators 900C and 900E, through which the reference line Z passes, may be formed as a combination of a surface portion and a protrusion, respectively. With this arrangement, when the rear indentation 68C is visually checked from underneath, it is ensured that, in the two indicators aligned in the front-rear direction, the indicator formed as a protrusion is provided separately from the rear wall 31C and to the front of the indicator formed as a surface portion. Therefore, the surface portion adjoining the rear wall 31C (the contour of the rear surface in the bottom view) does not extend over the lateral information section Y2. In other words, the protrusion that is separately disposed from the rear wall 31C can be identified as the protrusion provided in the lateral information section Y2. Therefore, a person can identify the position of the lateral information section Y1 by visually checking the surface portion of the indicator 900C, and the person can also identify the position of the lateral information section Y2 by visually checking the protrusion of the indicator 900E.

[0139] In the example of FIG. 13, among the plurality of overlapping areas formed by the lateral information sections Y1, Y2 and the vertical information sections X1 to X4, the overlapping areas of the lateral information section Y1 and the vertical information sections X1 to X4 respectively function as the indicators 900A to 900D, and the overlapping area of the lateral information section Y2 and the vertical information section X3 functions as the indicator 900E. In this case, if the color information is

identified by whether a protrusion is formed in each of the indicators 900A to 900E, it is also necessary to identify which of the indicators 900A to 900E includes a protrusion. If a person knows all the positions in the left-and-right direction of the vertical information sections X1 to X4 arranged in the rear indentation 68C, the person can identify to which of the indicators 900A to 900E the protrusion provided in the lateral information section Y1 or Y2 corresponds, using the vertical information sections X1 to X4 as references. In other words, the person can visually identify which of the indicators 900A to 900E, provided in the overlapping areas of the lateral information sections Y1, Y2 and the vertical information sections X1 to X4, includes the at least one protrusion provided in the specified area R0.

[0140] The positions in the left-and-right direction of the vertical information sections X1 to X4 can be identified in the following manner, by a person visually checking the rear indentation 68C. When the rear indentation 68C is visually checked from underneath (refer to FIG. 13), it may be possible to identify the position in the left-and-right direction of the vertical information section X3 that includes the indicators 900C and 900E, based on the indicators 900C and 900E that are formed by a combination of a protrusion and a surface portion aligned in the front-rear direction. Further, the vertical information sections X1 to X4 are lined up at substantially equal intervals in the left-and-right direction in the specified area R0. Therefore, by using the vertical information section X3 as a reference, it may be possible to identify the vertical information sections X2 and X1 that are lined up in this order in the left direction (in the right direction in FIG. 13) at equal intervals. It may also be possible to identify the vertical information section X4 that is arranged in the right direction (in the left direction in FIG. 13) at an equal interval. In this manner, even when the positions in the left-and-right direction of the vertical information sections X1 to X4 are not ascertained, it may be possible to identify the positions of the vertical information sections X1 to X4, by using as a reference the indicators (the combination of the protrusion and the surface portion) aligned in the front-rear direction.

[0141] For this reason, based on which of the vertical information sections X1 to X4 includes a protrusion provided in the lateral information section Y1, it may be possible to identify which of the indicators 900A to 900D is formed as a protrusion. Further, based on whether or not a protrusion provided in the lateral information section Y2 is located in the vertical information section X3, it may be possible to identify whether the indicator 900E is formed as a protrusion. In this manner, with the tape cassette 30 according to the present embodiment, it may be possible to identify the combination of the protrusion and the surface portion in the indicators 900A to 900E, by a person visually checking the rear indentation 68C.

[0142] Next, identification of the color information based on a combination of whether a

protrusion is formed in each of the lateral information sections Y1 and Y2 or in each of the indicators 900A to 900E will be explained. In the present embodiment, an example will be explained in which the tape color and the character color of the tape cassette 30 are identified as the color information of the tape cassette 30. Note that the tape color included in the color information indicates a base material color of the tape (the heat-sensitive paper tape 55, the print tape 57, or the double-sided adhesive tape 58). The character color included in the color information indicates an ink color of the ink ribbon 60 when thermal-transfer printing is performed using the ink ribbon 60. The character color also indicates a color developed by the heat-sensitive paper tape 55 when thermal printing that causes the heat-sensitive paper tape 55 to develop color is performed.

[0143] Color information element that each of the lateral information sections Y1 and Y2 indicates is determined in advance. In the present embodiment, the lateral information section Y1 is determined as a section that indicates information for identifying the tape color of the color information. The lateral information section Y2 is determined as a section that indicates information for identifying the character color of the color information. In this manner, the tape cassette 30 is structured such that a corresponding color information element can be identified with each of the lateral information sections alone, regardless of the structure of the other lateral information section.

[0144] Further, in a case where specific overlapping areas in the lateral information sections Y1 and Y2 function as the indicators 900A to 900E, the color information element that each of the indicators 900A to 900E indicates is determined in accordance with which of the lateral information sections Y1 and Y2 includes each of the indicators 900A to 900E. Accordingly, the indicators 900A to 900D are indicators for identifying the tape color of the color information, and the indicator 900E is an indicator for identifying the character color of the color information. In other words, the lateral information section Y1 and the indicators 900A to 900D each function as a tape color indicator portion, and the lateral information section Y2 and the indicator 900E each function as a character color indicator portion. A method for identifying the color information based on the indicators 900A to 900E will be described below as an example.

[0145] The tape color and the character color indicated by each of the indicator portions will be described with reference to Table 1 to Table 3. For explanatory purpose, in the Tables, a case where a protrusion is formed in each of the indicators 900A to 900E is denoted by a value one (1), and a case where each of the indicators 900A to 900E is a surface portion and no protrusion is formed therein is denoted by a value zero (0). Note that, in a case where the color information is identified based on a combination of the protrusion(s) and the surface portion(s) formed in the lateral information sections Y1 and Y2, the method for identifying the major tape color described below may be used,

with reference to a similar table in which the indicators 900B to 900D in Table 1 are respectively replaced with a combination of the protrusion(s) and the surface portion(s) provided at three locations in the lateral information section Y1. The method for identifying the special tape color described below may be used, with reference to a similar table in which the indicators 900A to 900D in Table 2 are replaced with a combination of the protrusion(s) and the surface portion(s) provided at four locations in the lateral information section Y1. The method for identifying the character color described below may be used, with reference to a similar table in which the indicator 900E in Table 3 is replaced with the protrusion or the surface portion provided at one location in the lateral information section Y2.

<Table 1>

Major Tape Color (Y1)	900B (X2)	900C (X3)	900D (X4)
Clear	1	1	0
Blue	0	1	1
Black	0	0	1

<Table 2>

Special Tape Color (Y1)	900A (X1)	900B (X2)	900C (X3)	900D (X4)
White	0	1	1	1
Yellow	1	0	1	0
Red	0	1	0	1

<Table 3>

Character Color (Y2)	900E (X3)
Black	0
Other than Black	1

[0146] First, a method, performed by human visual check, for identifying the color of the tape mounted in the tape cassette 30 will be described. In the present embodiment, the indicators 900A to 900D (the indicators in the lateral information section Y1) indicate the tape color based on a combination of the protrusion(s) and the surface portion(s). In particular, the tape color of the major tape that has a high likelihood of being mounted in the tape cassette 30 can be identified simply by visually checking the three indicators 900B to 900D. Further, the tape color for a special tape that has a low likelihood of being mounted in the tape cassette 30 can be identified by visually

checking the four indicators 900A to 900D.

[0147] As shown in Table 1, corresponding to combinations of whether the indicators 900B to 900D, which form the tape color indicator portion, are each formed as a protrusion or as a surface portion, three colors "clear" "blue" and "black" are respectively defined as major tape colors indicated by the combinations. Therefore, a person can recognize the tape color of the major tape mounted in the tape cassette 30 simply by visually checking, of the rear indicator portion 900, the indicators 900B to 900D within the lateral information section Y1.

[0148] More specifically, if the indicators 900B to 900D are respectively a protrusion, a protrusion, and a surface portion (the combination of "1, 1, 0" in Table 1), it indicates that the tape color is "clear". If the indicators 900B to 900D are respectively a surface portion, a protrusion, and a protrusion (the combination of "0, 1, 1" in Table 1), it indicates that the tape color is "blue". If the indicators 900B to 900D are respectively a surface portion, a surface portion, and a protrusion (the combination of "0, 0, 1" in Table 1), it indicates that the tape color is "black". For example, in the tape cassette 30 shown in FIG. 13 and FIG. 14, the indicators 900B to 900D are respectively a protrusion, a protrusion, and a surface portion. Therefore, the tape color can be identified as "clear".

[0149] The indicator 900C is provided in the vertical information section X3 that can be identified by using the reference line Z as a reference. Therefore, among the indicators 900A to 900D in the lateral information section Y1, the indicator 900C can most easily be identified by human visual check. Further, the indicators 900B and 900D that are respectively provided in the vertical information sections X2 and X4, which are located to the right and left of the vertical information section X3, can also easily be identified by human visual check. Therefore, the major tape color can be identified simply by checking the indicators 900B to 900D that can be identified by human visual check, among the indicators 900A to 900D in the lateral information section Y1.

[0150] As shown in Table 2, corresponding to combinations of whether the indicators 900A to 900D, which form the tape color indicator portion, are each formed as a protrusion or a surface portion, three colors "white" "yellow" and "red" are respectively defined as special tape colors indicated by the combinations. Therefore, a person can recognize the tape color of the special tape mounted in the tape cassette 30 simply by visually checking the indicators 900A to 900D within the lateral information section Y1 of the rear indicator portion 900.

[0151] More specifically, if the indicators 900A to 900D are respectively a surface portion, a protrusion, a protrusion, and a protrusion (the combination of "0, 1, 1, 1" in Table 2), it indicates that the tape color is "white". If the indicators 900A to 900D are respectively a protrusion, a surface portion, a protrusion, and a surface portion (the combination of

"1, 0, 1, 0" in Table 2), it indicates that the tape color is "yellow". If the indicators 900A to 900D are respectively a surface portion, a protrusion, a surface portion, and a protrusion (the combination of "0, 1, 0, 1" in Table 2), it indicates that the tape color is "red".

[0152] As shown in Table 3, corresponding to whether the indicator 900E, which is the character color indicator portion, is formed as a protrusion or a surface portion, "black" or "other than black" is defined as the character color. Therefore, a person can recognize the character color for the tape mounted in the tape cassette 30 by just visually checking the indicator 900E within the lateral information section Y2 of the rear indicator portion 900. More specifically, if the indicator 900E is a protrusion ("1" in Table 3), it indicates that the character color is "a color other than black". If the indicator 900E is a surface portion ("0" in Table 3), it indicates that the character color is "black". For example, in the tape cassettes 30 shown in FIG. 13 and FIG. 14, the indicator 900E is a surface portion. Therefore, the character color can be identified as "black".

[0153] In this manner, with the tape cassette 30 according to the present embodiment, regardless of whether the indicator 900E provided in the specified area R0 is formed as a protrusion or a surface portion, with respect to the major tape colors shown in Table 1, a person can identify the tape color simply by visually checking the indicators 900B to 900D. With respect to the special tape colors shown in Table 2, the person can identify the tape color simply by visually checking the indicators 900A to 900D. With respect to the character colors shown in Table 3, regardless of whether each of the indicators 900A to 900D provided in the specified area R0 is a protrusion or a surface portion, the person can identify the character color simply by visually checking the indicator 900E.

[0154] In the cassette case 31, the first and second tape housing areas 33A and 33B are provided to the rear, while the ink ribbon housing area 33C is provided to the front. Consequently, in the tape cassette 30 that uses the ink ribbon 60, the tape (the double-sided adhesive tape 58 in FIG. 3 and FIG. 4, and the print tape 57 in FIG. 5) and the ink ribbon 60 are aligned in the front-rear direction inside the cassette case 31, corresponding to the arrangement order in the front-rear direction of the lateral information sections Y1 and Y2. Therefore, the person can identify the base material color of the tape located to the rear of the ink ribbon, by visually checking the lateral information section Y1 that indicates the tape color, which is to the rear side of the lateral information section Y2. Further, the person can identify the ink color of the ink ribbon located to the front of the tape, by visually checking the lateral information section Y2 that indicates the character color, which is to the front side of the lateral information section Y1. Thus, based on the arrangement of the tape and the ink ribbon inside the cassette case 31, a person can accurately identify the color information indicated by the

lateral information sections Y1 and Y2.

[0155] The contents of the color information (the tape color and the character color) indicated by each of the indicator portions are not limited to those shown in Table 1 to Table 3, and can be modified as necessary. Additionally, although the total number of combinations of the color information defined in Table 1 to Table 3 is twenty eight, all of the combinations need not necessarily be used. However, it may be preferable that the combination of the protrusion(s) and the surface portion(s) corresponding to the color information is defined at least in accordance with the following rules.

[0156] First, it may be desirable that at least one of the indicators 900A, 900B and 900D, except the indicator 900C that can easily be identified using the reference line Z as a reference, is formed as a protrusion, and at least one of the indicators 900A, 900B and 900D is formed as a surface portion. In this case, when a person visually checks the indicators 900A to 900D, it may be possible to improve visibility of the combination of the protrusion(s) and the surface portion(s) of the indicators 900A to 900D, and it may be possible for the person to easily identify the combination.

[0157] Second, it may be desirable that the following two combinations are not employed. One is a combination in which all the indicators 900A to 900D within the lateral information section Y1 are surface portions. The other is a combination in which all the indicators 900A to 900E within the specified area R0 are surface portions. In such combinations, the entire rear indentation 68C may be formed as a surface portion in which only one protrusion is formed at a position separated from the rear wall 31C, or as a surface portion including no protrusion. Then, it may be difficult for a person to ascertain that the rear indicator portion 900 is provided in the rear indentation 68C in the first place. Therefore, by providing at least one protrusion in a position adjoining the rear wall 31C, it may be possible to make clear that the rear indicator portion 900 is provided in the rear indentation 68C.

[0158] Third, for the color information of the tape that has a high likelihood of being mounted in the tape cassette 30, it may be desirable that one of the indicators 900C and 900E that are aligned in the front-rear direction in the rear indentation 68C is a protrusion, and the other indicator is a surface portion. In this case, the person can identify the element of the lateral information section Y2 by visually checking the rear indentation 68C as described above.

[0159] Fourth, when the tape color of the tape cassette 30 is identified by human visual check, regardless of whether the tape color is a major tape color or a special tape color, whether each of the indicators 900B to 900D is a protrusion or a surface portion is necessary information to identify the tape color. Therefore, it may be preferable that the color information corresponding to the special tape colors shown in Table 2 does not include the color information corresponding to the major tape colors shown in

Table 1. More specifically, it may be desirable that the color information of the special tape colors (refer to Table 2) does not include combinations in which the indicators 900B to 900D are "a protrusion, a protrusion, a surface portion", "a surface portion, a protrusion, a protrusion", and "a surface portion, a surface portion, a protrusion". Thus, when a person visually checks the rear indentation 68C, it may be possible to clearly distinguish whether it is the major tape color or the special color, and it may be possible to easily identify the tape color.

[0160] The structure for the rear indicator portion 900 to indicate the color information, and the method for identifying the color information by a person visually checking the rear indicator portion 900 are described above. Hereinafter, the structure of the rear indicator portion 900 in relation to the rear detecting switches 310 of the tape printer 1, and color information identification by the rear detecting switches 310 will be described.

[0161] First, the structure of the rear indicator portion 900 in relation to the rear detecting switches 310 of the tape printer 1 will be described. As described above, in the tape printer 1 of the present embodiment, the rear detection portion 300 provided in the rear support portion 8C has the five rear detecting switches 310A to 310E (refer to FIG. 2 and FIG. 7). In the tape cassette 30, the overlapping areas that respectively face the rear detecting switches 310A to 310E when the tape cassette 30 is installed in the cassette housing portion 8 are formed as the indicators 900A to 900E (refer to FIG. 13 and FIG. 14).

[0162] When the tape cassette 30 is installed in the cassette housing portion 8, the positioning pins 102 and 103 are respectively inserted in the pin holes 62 and 63. At the same time, the rear support pin 301 contacts with the rear indentation 68C (refer to FIG. 16). Thus, the tape cassette 30 is supported by the positioning pins 102 and 103, and by the rear support pin 301 at a predetermined height position. Meanwhile, the switch terminals 322 of the rear detecting switches 310 each protrude upwards toward the rear indicator portion 900. The leading end of each switch terminal 322 may extend higher than the lower surface 32B of the corner portions 32A and lower than the rear indentation 68C.

[0163] The surface portion is a part of the rear indentation 68C that opposes the leading end of the rear detecting switch 310 with a small gap therebetween when the tape cassette 30 is installed in the cassette housing portion 8. Therefore, the surface portion functions as the non-pressing portion 901 that does not press the switch terminal 322. The rear detecting switch 310 that opposes the non-pressing portion 901 remains in an off state, as the switch terminal 322 is not pressed.

[0164] The protrusion functions as the pressing portion 902 that opposes and presses the switch terminal 322 of the rear detecting switch 310 when the protrusion opposes the

rear detecting switch 310. The rear detecting switch 310 that opposes the pressing portion 902 is changed to an on state, as the switch terminal 322 contacts with the pressing portion 902. For example, as shown in FIG. 11 and FIG. 13, the pressing portion 902 may be formed as a generally cylindrical protrusion that extends from the rear indentation 68C to a lower position than the lower surface 32B. The pressing portion 902 may have a circular shape that occupies an almost entire area of the each of the indicators 900A to 900E (the overlapping area) in a bottom view.

[0165] Thus, in the tape cassette 30 of the present embodiment, the non-pressing portion 901 is a part of the rear indentation 68C that is located at a higher position than the lower surface 32B, while the pressing portion 902 is a protrusion protruding downward from the rear indentation 68C to a lower position than the lower surface 32B. Therefore, when the tape cassette 30 is installed in the cassette housing portion 8, each of the rear detecting switches 310 is maintained in the off state or changed to the on state, due to the difference in the height positions of the non-pressing portion 901 and the pressing portion 902. In the examples shown in FIG. 13 and FIG. 14, the indicators 900A, 900D and 900E are the non-pressing portions 901, and the indicators 900B and 900C are the pressing portions 902.

[0166] As described above with reference to Table 1 to Table 3, either a surface portion (the non-pressing portion 901) or a protrusion (the pressing portion 902) is formed in each of the indicators 900A to 900E of the rear indicator portion 900, in accordance with a prescribed pattern that corresponds to the color information. Accordingly, the tape printer 1 can identify the color information based on the combination of the on and off states of the rear detecting switches 310 that are selectively pressed by the rear indicator portion 900. More specifically, the prescribed pattern (the combination of the protrusion(s) and the surface portion(s)) that is defined in advance for the indicators 900A to 900E as described above can be converted to a detection pattern (the combination of the on and off states) of the corresponding rear detecting switches 310A to 310E. Then, the tape printer 1 can identify the color information with reference to a table in which each detection pattern is associated with the color information.

[0167] A color information table 520 shown in FIG. 18 is an example of a table used in the tape printer 1 to identify the color information, and is stored in the ROM 402 of the tape printer 1. The color information of the tape cassette 30 is defined in the color information table 520 in accordance with the combination of the on and off states of the five rear detecting switches 310A to 310E. In the color information table 520 shown in FIG. 18, the rear detecting switches 310A to 310E respectively correspond to switches "ST1" to "ST5", and the off state (OFF) and the on state (ON) of each of the rear detecting switches 310 correspond to the values zero "0" and one "1", respectively.

[0168] The color information table 520 of the present embodiment includes a plurality of

color tables to respectively identify different color information corresponding to different detection patterns of the rear detecting switches 310A to 310E. In the example shown in FIG. 18, the color information table 520 includes a first color table 521 and a second color table 522. In the first color table 521, first color information is defined in association with detection patterns of the rear detecting switches 310A to 310E. In the second color table 522, second color information is defined in association with the detection patterns of the rear detecting switches 310A to 310E. In the present embodiment, the first color table 521 is a standard color table that includes the color information that is frequently used, and the second color table 522 is a special color table that includes the color information that is less frequently used. In the tape printer 1, the first color table 521 and the second color table 522 are selectively used, and the color information (the first color information or the second color information) is identified in accordance with the detection pattern of the rear detecting switches 310A to 310E, as will be described later.

- [0169] The table that can be used in the tape printer 1 is not limited to the color information table 520 shown in FIG. 18. For example, any selected color information may be newly added corresponding to "spare" field in the color information table 520. In addition, the color information that is recorded in the color information table 520 may be deleted, the correspondence between each detection pattern and the color information may be changed, or the content of the color information corresponding to each detection pattern may be changed. In such a case, the above-described pattern of the protrusion(s) that is determined for identification of the color information by a visual check may also be changed as necessary.
- [0170] Next, detection modes of the tape type of the tape cassette 30 by the tape printer 1 will be explained with reference to FIG. 3 to FIG. 6, FIG. 15 and FIG. 16.
- [0171] First, detection modes of the arm indicator portion 800 by the arm detection portion 200 will be explained with reference to FIG. 3 to FIG. 6 and FIG. 15. When the tape cassette 30 is installed at the proper position in the cassette housing portion 8 by the user and the cassette cover 6 is closed, the platen holder 12 moves from the stand-by position (refer to FIG. 3) to the print position (refer to FIG. 4 to FIG. 6). Then, the arm detection portion 200 and the latching piece 225 provided on the cassette-facing surface 12B of the platen holder 12 move to the positions that respectively oppose the arm indicator portion 800 and the latching hole 820 provided on the arm front wall 35 of the tape cassette 30.
- [0172] In a case where the tape cassette 30 is installed in the cassette housing portion 8 at the proper position, the latching piece 225 is inserted into the latching hole 820. As a result, the latching piece 225 does not interfere with the tape cassette 30, and the switch terminals 222 of the arm detecting switches 210 that protrude from the cassette-

facing surface 12B oppose the indicators 800A to 800E (the non-pressing portions 801 and the pressing portion 802) that are provided at the corresponding positions in the arm indicator portion 800, and are selectively pressed. More specifically, the arm detecting switch 210 opposing the non-pressing portion 801 remains in the off state by being inserted into the aperture that is the non-pressing portion 801. The arm detecting switch 210 opposing the pressing portion 802 is changed to the on state by being pressed by the surface portion of the arm front wall 35 that is the pressing portion 802.

[0173] For example, in a case where the tape cassette 30 shown in FIG. 2 and FIG. 10 to FIG. 14 is installed at the proper position in the cassette housing portion 8, the arm detecting switches 210A, 210C and 210D are in the off state (0), because they respectively oppose the indicators 800A, 800C and 800D that are the non-pressing portions 801, as shown in FIG. 15. On the other hand, the arm detecting switches 210B and 210E are in the on state (1), because they respectively oppose the indicators 800B and 800E that are the pressing portions 802. More specifically, the values that indicate the on and off states of the arm detecting switches 210A to 210E are identified as "0", "1", "0", "0", "1", respectively.

[0174] In the tape printer 1, based on the detection pattern of the arm detection portion 200 (here, the combination of the on and off states of the five arm detecting switches 210A to 210E), the print information is identified as the tape type of the tape cassette 30. In the present embodiment, the print information of the tape cassette 30 includes the tape width and the print mode. The "tape width" included in the print information indicates one of seven types of tape width from 3.5mm to 36mm. The "print mode" included in the print information indicates whether the print mode is a mirror image printing mode (laminated) or a normal image printing mode (receptor).

[0175] The ROM 402 of the tape printer 1 stores a print information table (not shown in the figures) in which the print information of the tape cassette 30 is defined in association with the combinations of the on and off states of the five arm detecting switches 210A to 210E. In the above-described example, with reference to the print information table (not shown in the figures), for example, "tape width: 36mm, print mode: laminated" is identified as the print information in accordance with the on and off states "0", "1", "0", "0", "1" of the arm detecting switches 210A to 210E.

[0176] Next, detection modes of the rear indicator portion 900 by the rear detection portion 300 will be explained with reference to FIG. 16. When the tape cassette 30 is installed at the proper position in the cassette housing portion 8 by the user, the rear detection portion 300 provided in the rear support portion 8C of the tape printer 1 opposes the rear indicator portion 900 provided in the rear indentation 68C of the tape cassette 30. More specifically, the switch terminals 322 (refer to FIG. 2 and FIG. 7) of the rear detecting switches 310 that protrude from the rear support portion 8C oppose the in-

dicators (the non-pressing portion 901 and the pressing portion 902) provided at the corresponding positions in the rear indicator portion 900, and are selectively pressed. Consequently, the rear detecting switch 310 that opposes the non-pressing portion 901 remains in an off state, without being pressed. On the other hand, the rear detecting switch 310 that opposes the pressing portion 902 is pressed by the pressing portion 902, and is changed to an on state.

[0177] For example, in a case where the tape cassette 30 shown in FIG. 2 and FIG. 10 to FIG. 14 is installed at the proper position in the cassette housing portion 8, as shown in FIG. 16, the rear detecting switches 310A, 310D and 310E respectively oppose the indicators 900A, 900D and 900E, which are the non-pressing portions 901, and therefore remain in the off state. Meanwhile, the rear detecting switches 310B and 310C respectively oppose the indicators 900B and 900C, which are the pressing portions 902, and are therefore changed to the on state. Consequently, the values indicating the on and off states of the switches "ST1" to "ST5" that respectively correspond to the rear detecting switches 310A to 310E are identified as "0", "1", "1", "0" "0", respectively.

[0178] In the tape printer 1, the color information is identified as the tape type of the tape cassette 30, based on the detection pattern (here, the combination of the on and off states of the five rear detecting switches 310A to 310E) of the rear detection portion 300. In the above-described example, with reference to the above-described color information table 520 (refer to FIG. 18), the color information corresponding to the on and off states "0", "1", "1", "0" "0" of the rear detecting switches 310A to 310E is identified. However, the identified color information varies depending on which of the color tables 521 and 522 included in the color information table 520 is used. Here, the standard first color table 521 is used in accordance with the off state of the arm detecting switch 210D to be described later, and the color information "tape color: clear, character color: black" is identified similarly to the above-described identification result by a visual check.

[0179] Next, processing relating to printing performed in the tape printer 1 according to the present embodiment will be explained with reference to FIG. 17. The processing relating to printing shown in FIG. 17 is performed by the CPU 401 based on programs stored in the ROM 402 when the power source of the tape printer 1 is switched on.

[0180] As shown in FIG. 17, in the processing relating to printing, first, system initialization of the tape printer 1 is performed (step S1). For example, in the system initialization performed at step S1, the text memory in the RAM 404 is cleared, and a counter is initialized to a default value.

[0181] Next, the print information of the tape cassette 30 is identified based on the detection pattern of the arm detection portion 200 (namely, based on the combination of the on and off states of the arm detecting switches 210) (step S3). At step S3, as described

above, with reference to the print information table (not shown in the figures) stored in the ROM 402, the print information corresponding to the combination of the on and off states of the arm detecting switches 210A to 210E is identified.

[0182] Then, it is determined whether or not the arm detecting switch 210D (hereinafter referred to as the switch SW4), among the plurality of arm detecting switches 210, is in the on state (step S5). When the switch SW4 is in the off state (no at step S5), the first color table 521 is selected from among the color tables included in the color information table 520 stored in the ROM 402 (step S7). When the switch SW4 is in the on state (yes at step S5), the second color table 522 is selected from among the color tables included in the color information table 520 stored in the ROM 402 (step S9).

[0183] Next, the color information of the tape cassette 30 is identified based on the detection pattern of the rear detection portion 300 (namely, based on the combination of the on and off states of the plurality of rear detecting switches 310) (step S11). At step S11, with reference to the color table selected at step S7 or at step S9, the color information corresponding to the combination of the on and off states of the plurality of rear detecting switches 310 is identified. In the present embodiment, in the tape cassette 30 of the tape type that is manufactured in large quantities, the indicator 800D corresponding to the arm detecting switch 210D is formed as the non-pressing portion 801. For that reason, at step S11, in many cases, the color information is identified with reference to the standard first color table 521.

[0184] Thus, in the present embodiment, the color table to be used to identify the color information of the tape cassette 30 is selected in accordance with the detection state of a particular arm detecting switch 210 (here, the on or off state of the arm detecting switch 210D). Therefore, without increasing the number of the rear detecting switches 310 (namely, without increasing the area occupied by the rear detection portion 300), it may be possible to increase the number of color information patterns that can be identified by the tape printer 1.

[0185] In the processing relating to printing (refer to FIG. 17), the print information identified at step S3 and the color information identified at step S11 are displayed on the display 5 as text information (step S13). In a case where the above-described tape cassette 30 (refer to FIG. 2 and FIG. 10 to FIG. 14) is properly installed, the display 5 displays a message that reads, for example, "A 36mm laminated-type tape cassette has been installed. The tape color is clear and the character color is black."

[0186] Next, it is determined whether there is any input from the keyboard 3 (step S15). If there is an input from the keyboard 3 (yes at step S15), the CPU 401 receives the characters input from the keyboard 3 as print data, and stores the print data (text data) in the text memory of the RAM 404 (step S17). If there is no input from the keyboard 3 (no at step S15), the processing returns to step S15 and the CPU 401 waits for an

input from the keyboard 3.

[0187] Then, if there is an instruction to start printing from the keyboard 3, for example, the print data stored in the text memory is processed in accordance with the print information identified at step S3 (step S19). For example, at step S19, the print data is processed such that a print range and a print size corresponding to the tape width identified at step S3, and a print position corresponding to the print mode (the mirror image printing mode or the normal image printing mode) identified at step S3 are incorporated. Based on the print data processed at step S19, print processing is performed on the tape that is the print medium (step S21). After the print processing is performed, the processing relating to printing (refer to FIG. 17) ends.

[0188] The above-described print processing (step S21) will be explained below more specifically. In a case where the laminated type tape cassette 30 shown in FIG. 3 and FIG. 4 is installed, the tape drive roller 46, which is driven to rotate via the tape drive shaft 100, pulls out the film tape 59 from the second tape spool 41 by moving in concert with the movable feed roller 14. Further, the ribbon take-up spool 44, which is driven to rotate via the ribbon take-up shaft 95, pulls out the unused ink ribbon 60 from the ribbon spool 42 in synchronization with the print speed. The film tape 59 that has been pulled out from the second tape spool 41 passes the outer edge of the ribbon spool 42 and is fed along the feed path within the arm portion 34.

[0189] Then, the film tape 59 is discharged from the exit 34A toward the head insertion portion 39 in a state in which the ink ribbon 60 is joined to the surface of the film tape 59. The film tape 59 is then fed between the thermal head 10 and the platen roller 15 of the tape printer 1. Then characters are printed onto the print surface of the film tape 59 by the thermal head 10. Following that, the used ink ribbon 60 is separated from the printed film tape 59 at the guide wall 47 and wound onto the ribbon take-up spool 44.

[0190] Meanwhile, the double-sided adhesive tape 58 is pulled out from the first tape spool 40 by the tape drive roller 46 moving in concert with the movable feed roller 14. While being guided and caught between the tape drive roller 46 and the movable feed roller 14, the double-sided adhesive tape 58 is layered onto and affixed to the print surface of the printed film tape 59. The printed film tape 59 to which the double-sided adhesive tape 58 has been affixed (namely, the printed tape 50) is then fed toward the tape discharge portion 49, discharged from the discharge portion 49, and is cut by the cutting mechanism 17.

[0191] In a case where the receptor type tape cassette 30 shown in FIG. 5 is installed, the tape drive roller 46, which is driven to rotate via the tape drive shaft 100, pulls out the print tape 57 from the first tape spool 40 by moving in concert with the movable feed roller 14. Further, the ribbon take-up spool 44, which is driven to rotate via the ribbon take-up shaft 95, pulls out the unused ink ribbon 60 from the ribbon spool 42 in syn-

chronization with the print speed. The print tape 57 that has been pulled out from the first tape spool 40 is bent in the leftward direction in the front right portion of the cassette case 31, and fed along the feed path within the arm portion 34.

[0192] Then, the print tape 57 is discharged from the exit 34A toward the head insertion portion 39 in a state in which the ink ribbon 60 is joined to the surface of the print tape 57. The print tape 57 is then fed between the thermal head 10 and the platen roller 15 of the tape printer 1. Then, characters are printed onto the print surface of the print tape 57 by the thermal head 10. Following that, the used ink ribbon 60 is separated from the printed print tape 57 at the guide wall 47 and wound onto the ribbon take-up spool 44. Meanwhile, the printed print tape 57 (in other words, the printed tape 50) is then fed toward the tape discharge portion 49, discharged from the discharge portion 49, and is cut by the cutting mechanism 17.

[0193] In a case where the thermal type tape cassette 30 shown in FIG. 6 is installed, when printing is performed, the tape drive roller 46, which is driven to rotate via the tape drive shaft 100, pulls out the heat-sensitive paper tape 55 from the first tape spool 40 by moving in concert with the movable feed roller 14. The heat-sensitive paper tape 55 that has been pulled out from the first tape spool 40 is bent in the leftward direction in the front right portion of the cassette case 31, and is fed along the feed path within the arm portion 34.

[0194] Then, the heat-sensitive paper tape 55 is discharged from the exit 34A of the arm portion 34, and is then fed between the thermal head 10 and the platen roller 15. Then, characters are printed onto the print surface of the heat-sensitive paper tape 55 by the thermal head 10. Following that, the printed heat-sensitive paper tape 55 (namely, the printed tape 50) is further fed toward the tape discharge portion 49 by the tape drive roller 46 moving in concert with the movable feed roller 14, discharged from the discharge portion 49, and is cut by the cutting mechanism 17.

[0195] In the above-described print processing (step S21), in a case where the laminated type tape cassette 30 is installed, mirror image printing is performed. In mirror image printing, the ink of the ink ribbon 60 is transferred onto the film tape 59 such that the characters are shown as a mirror image. On the other hand, in a case where the receptor type tape cassette 30 is installed, normal image printing is performed. In normal image printing, the ink of the ink ribbon 60 is transferred onto the print tape 57 such that the characters are shown as a normal image. Further, in a case where the thermal type tape cassette 30 is installed, thermal type normal image printing is performed on the heat-sensitive paper tape 55 such that the characters are color developed as a normal image.

[0196] In the present embodiment, the print mode "laminated" is applied to the tape cassette 30 with which mirror image printing is performed, while the print mode "receptor" is applied to the tape cassette 30 with which normal image printing is performed. For that

reason, the print mode "receptor" is applied not only to the receptor type tape cassette 30 shown in FIG. 5, but also to the thermal type tape cassette 30 shown in FIG. 6.

[0197] Through the above-described processing relating to printing (refer to FIG. 17), the tape type of the tape cassette 30 installed in the cassette housing portion 8 is identified by the tape printer 1, based on the detection pattern of the arm detection portion 200 and the detection pattern of the rear detection portion 300. More specifically, the arm detecting switches 210A to 210E on the arm detection portion 200 are selectively pressed by the arm indicator portion 800 provided on the arm front wall 35 of the tape cassette 30, and the print information of the tape cassette 30 is thus identified. Further, the rear detecting switches 310A to 310E on the rear detection portion 300 are selectively pressed by the rear indicator portion 900 provided on the bottom wall 30B (more specifically, the rear indentation 68C) of the tape cassette 30, and the color information of the tape cassette 30 is thus identified.

[0198] As described above, the tape cassette 30 according to the present embodiment is structured such that when a person looks at the tape cassette 30 alone, the person can identify the tape type (here, the color information) by visually checking the rear indentation 68C. In addition, the tape cassette 30 is structured such that when the tape cassette 30 is installed in the cassette housing portion 8 of the tape printer 1, the tape printer 1 can identify the tape type with the rear detection portion 300 detecting information indicated by the rear indicator portion 900. Of the foregoing structures, as a result of structuring the tape cassette 30 such that a person can recognize the color information by visually checking the rear indicator portion 900, the following effects may be particularly exhibited.

[0199] In a conventional manufacturing method for tape cassettes, it is a general practice to house a tape or the like in a cassette case in accordance with a type of a tape cassette. For example, in accordance with the color information (a combination of the tape color and the character color) of the tape to be mounted in the tape cassette, a worker mounts, in the cassette case, a tape whose base material color matches the tape color, and an ink ribbon with an ink color that matches the character color. However, there are a variety of combinations of tape colors and character colors. Therefore, when tape cassettes are manufactured, the worker may mistakenly mount a tape or an ink ribbon that does not correspond to the color information of the tape or the ink ribbon to be mounted in the tape cassette.

[0200] With the tape cassette 30 according to the present embodiment, in the manufacturing process of the tape cassette 30, a worker can check the rear indicator portion 900 by turning over the bottom case 31B before mounting a tape or the like, and visually checking the rear indentation 68C from the bottom surface side of the cassette case 31. Therefore, the worker can identify the color information intended for the cassette case

31, and can ascertain the tape color and the character color of the tape or the like that should be housed in the cassette case 31. As a consequence, in the manufacturing process of the tape cassette 30, the worker can work while confirming the contents to be housed in the cassette case 31, and thus errors in the manufacture of the tape cassette 30 may be reduced.

[0201] Furthermore, after the tape cassettes 30 has been shipped from the plant, even if the tape type or the like written on a label cannot be read for some reason, the worker can recognize the color information by visually checking the tape cassette 30 from the bottom surface side. Therefore, the worker can easily select the tape cassette 30 having desired color information from among a plurality of the tape cassettes 30.

[0202] In addition, the rear indicator portion 900 indicates the color information using a simple structure formed of a combination of a presence and an absence of a protrusion (namely, a combination of the non-pressing portion(s) 901 and the pressing portion(s) 902) in each of the lateral information sections Y1 and Y2. Therefore, the rear indicator portion 900 may be formed easily on the cassette case 31 in advance. For that reason, at the time of manufacture of the cassette case 31, there may be no need to print the contents to be housed in the cassette case 31, nor to affix labels to indicate the contents, and therefore errors in the manufacture of the tape cassette 30 can be reduced at a low cost.

[0203] Moreover, in the present embodiment, the laminated type tape cassette 30 formed from the general purpose cassette is used in the general purpose tape printer 1. Therefore, a single tape printer 1 can be used with each type of the tape cassette 30, such as the thermal type, the receptor type, and the laminated type etc., and it may not be necessary to use the different tape printer 1 for each type. Furthermore, the tape cassette 30 is normally formed by injecting plastic into a plurality of combined dies. In the case of the tape cassette 30 that corresponds to the same tape width, common dies can be used, except for the die including the portion that forms the rear indicator portion 900. Thus, costs may be significantly reduced.

[0204] In the example described above, the specified area R0 of the rear indentation 68C includes overlapping areas that function as the indicators 900A to 900E, each of which includes either a surface portion (namely, the non-pressing portion 901) or a protrusion (namely, the pressing portion 902) corresponding to the color information. In such a case, in the specified area R0, a protrusion and a surface portion may be formed freely as long as the functions of the indicators 900A to 900E are maintained.

[0205] More specifically, with the above-described tape cassette 30 shown in FIG. 2 and FIG. 10 to FIG. 14, all the areas in the specified area R0 that do not function as the indicators 900A to 900E are surface portions that are in the same plane as the non-pressing portions 901. Therefore, the protrusions (the pressing portions 902) provided

in the specified area R0 are formed separately from each other. However, it may not be necessary that the protrusions are all separated from each other. For example, one continuous protrusion having a size and shape that include at least two of the pressing portions 902 may be formed in the specified area R0. Note, however, that in a case where one continuous protrusion is formed, the continuous protrusion needs to be formed such that the continuous protrusion does not include a part that functions as the non-pressing portion 901.

[0206] FIG. 19 and FIG. 20 show an example of the tape cassette 30 in which each of the pressing portions 902 provided in the indicators 900B and 900C are made continuous to form a continuous protrusion 903. In the tape cassette 30 shown in FIG. 19 and FIG. 20, a combination of the indicators 900A to 900E is the same with that of the tape cassette 30 shown in FIG. 2, and FIG. 10 to FIG. 14. Therefore, the same color information is identified as the tape cassette 30 shown in FIG. 2, and FIG. 10 to FIG. 14, by either detection of the rear detecting switches 310 or by human visual check.

[0207] In the above-described embodiment, the cassette case 31 corresponds to a housing of the present invention. The heat-sensitive paper tape 55, the print tape 57, the double-sided adhesive tape 58 and the film tape 59 housed in the cassette case 31 of the tape cassette 30 each correspond to a tape of the present invention. The first tape housing area 33A and the second tape housing area 33B collectively correspond to a tape housing area of the present invention, the first tape housing area 33A corresponds to a first tape housing area of the present invention, and the second tape housing area 33B corresponds to a second tape housing area of the present invention. The ink ribbon housing area 33C corresponds to an ink ribbon housing area of the present invention. The rear indicator portion 900 corresponds to a color indicator portion of the present invention. The pressing portion 902 corresponds to a protrusion of the present invention. The lateral information sections Y1 and Y2 correspond to a plurality of lateral information sections of the present invention, the lateral information section Y1 corresponds to a first lateral information section of the present invention, and the lateral information section Y2 corresponds to a second lateral information section of the present invention. The vertical information section X3 corresponds to a reference vertical information section of the present invention, the vertical information sections X1, X2 and X4 each correspond to a subordinate vertical information section of the present invention, and the vertical information sections X1 to X4 correspond to a plurality of vertical information sections of the present invention. The lower surface 32B corresponds to a common surface portion of the present invention. The rear indentation 68C corresponds to a reference surface portion of the present invention. The corner portions 32A correspond to common height portions.

[0208] The tape drive shaft 100 corresponds to a feeding device of the present invention.

The thermal head 10 corresponds to a printing device of the present invention. The rear detecting switches 310A to 310E correspond to a plurality of detecting switches. The rear detecting switches 310 to 310D each correspond to a first area detecting switch, and the rear detecting switch 310E corresponds to a second area detecting switch of the present invention. The color information table 520 corresponds to a color information table of the present invention. The ROM 402 corresponds to a table storage device of the present invention. The CPU 401 that performs the processing relating to printing (refer to FIG. 19) corresponds to a color identifying device of the present invention.

[0209] The tape cassette 30 and the tape printer 1 of the present invention are not limited to those in the above-described embodiment, and various modifications and alterations may of course be made insofar as they are within the scope of the present invention.

[0210] The shape, size, number and arrangement pattern of the non-pressing portion(s) 901 and the pressing portion(s) 902 of the rear indicator portion 900 are not limited to the examples represented in the above-described embodiment, but can be modified as appropriate. For example, in the above-described embodiment, the pressing portion 902 (protrusion) of the rear indicator portion 900 is a generally cylindrical protrusion. However, the pressing portion 902 can be modified in size and shape as far as it is capable of pressing the opposing switch terminal 322 of the rear detecting switch 310 to make it in the on state. For example, the pressing portion 902 may be a hemispherical protrusion that has a circular shape in a bottom view that generally includes the overlapping area. Alternatively, the pressing portion 902 may be a parallelepiped protrusion that has a square shape in a bottom view that generally matches the overlapping area, or the pressing portion 902 may have any other different shape.

[0211] Further, the color information table 520 includes the first color table 521 and the second color table 522, and either the first color table 521 or the second color table 522 is selected based on the detection result of the arm detecting switch 210D. However, the color information table 520 may include a single color table.

Claims

- [Claim 1] A tape cassette (30), comprising:
a housing (31) including a top wall (31A) having a top surface, a bottom wall (31B) having a bottom surface, and a side wall (31C), the top wall and the bottom wall having a rectangular shape whose longitudinal direction is a left-and-right direction of the housing, the top wall, the bottom wall, and the side wall defining a periphery of the housing;
at least one tape (55, 57, 58, 59) mounted in a tape housing area (33A and 33B) defined within the periphery; and
a color indicator portion (900) disposed between the tape housing area and the periphery, and in a specified area (R0) adjacent to the tape housing area on a rear edge side of the bottom wall, the color indicator portion indicating color information relating to the at least one tape and including a plurality of lateral information sections (Y1 and Y2), the plurality of lateral information sections being a plurality of strip-shaped sections extending along the left-and-right direction of the housing and aligned in a front-rear direction of the housing,
wherein:
a presence or an absence of a first protrusion (902) that protrudes downward from the bottom surface and is formed in a first lateral information section (Y1) indicates, as the color information, a base material color of the at least one tape, the first lateral information section being one of the plurality of lateral information sections and adjoining the rear edge of the bottom wall.
- [Claim 2] The tape cassette according to claim 1, wherein a presence or an absence of a second protrusion (902) that protrudes downward from the bottom surface and is formed in a second lateral information section (Y2) indicates, as the color information, a print color of the at least one tape, the second lateral information section being another of the plurality of lateral information sections and located to the front of the first lateral information section.
- [Claim 3] The tape cassette according to claim 2, further comprising:
an ink ribbon (60) mounted in a ribbon housing area (33C) defined within the periphery,
wherein the print color is an ink color of the ink ribbon.
- [Claim 4] The tape cassette according to claim 3, wherein:

- the tape housing area is located to a rear side within the housing; and the ribbon housing area is located to a front side within the housing.
- [Claim 5] The tape cassette according to claim 2, wherein:
the at least one tape includes a heat-sensitive color development tape (55); and
the print color is a color developed by the heat-sensitive color development tape.
- [Claim 6] The tape cassette according to any one of claims 1 to 5, wherein, if the color indicator portion indicates a special color as the base material color, the protrusion is formed in a specified position of the first lateral information section.
- [Claim 7] The tape cassette according to any one of claims 2 to 6, wherein:
if the protrusion is not formed in the second lateral information section, the color indicator portion indicates that the print color is black; and
if the protrusion is formed in the second lateral information section, the color indicator portion indicates that the print color is a color other than black.
- [Claim 8] The tape cassette according to any one of claims 2 to 7, wherein:
the tape housing area includes a first tape housing area (33A) and a second tape housing area (33B), the first and second tape housing areas each having a generally circular shape in a plan view, the first and second tape housing areas being aligned with each other in the left-and-right direction such that outer peripheral edges of the first and second tape housing areas contact with each other;
the at least one tape is wound and mounted in at least one of the first and second tape housing areas;
the color indicator portion includes a reference vertical information section (X3) that is a strip-shaped section extending along the front-rear direction of the housing and that includes a reference line (Z), the reference line being an imaginary line extending along the front-rear direction and passing through a contact point (P) of the outer peripheral edges of the first and second tape housing areas; and
the protrusion provided in at least one of the first and second lateral information sections is provided at least in the reference vertical information section.
- [Claim 9] The tape cassette according to claim 8, wherein:
the color indicator portion includes a plurality of vertical information sections (X1 to X4) that are a plurality of strip-shaped sections

extending along the front-rear direction of the housing and aligned in the left-and-right direction of the housing;
the plurality of vertical information sections include the reference vertical information section and a subordinate vertical information section (X1, X2, X4) arranged in parallel with the reference vertical information section; and
the protrusion provided in at least one of the first lateral information section and the second lateral information section is provided in at least one of the reference vertical information section and the subordinate vertical information section.

[Claim 10]

The tape cassette according to any one of claims 2 to 7, wherein:
the color indicator portion includes a plurality of vertical information sections (X1 to X4) that are a plurality of strip-shaped sections extending along the front-rear direction of the housing and aligned in the left-and-right direction of the housing; and
if the protrusion adjoining the rear edge of the bottom wall is formed in a predetermined vertical information section among the plurality of vertical information sections, and if a front side of the protrusion is a surface portion separately disposed from the rear edge, an area where the predetermined vertical information section and the first lateral information section intersect and overlap with each other is the protrusion, and an area where the predetermined vertical information section and the second lateral information section intersect and overlap with each other is the surface portion.

[Claim 11]

The tape cassette according to claim 9 or 10, wherein
if the color indicator portion includes the protrusion formed in at least two of a plurality of overlapping areas, the protrusion is formed as protrusions separated from each other in each of the at least two of the plurality of overlapping areas, the overlapping areas being areas where the plurality of lateral information sections and the plurality of vertical information sections intersect and overlap with each other.

[Claim 12]

The tape cassette according to claim 9 or 10, wherein
if the color indicator portion includes the protrusion formed in at least two of a plurality of overlapping areas, the protrusion includes at least one protrusion that is formed over the at least two of the plurality of overlapping areas, the overlapping areas being areas where the plurality of lateral information sections and the plurality of vertical information sections intersect and overlap with each other.

[Claim 13]

The tape cassette according to any one of claims 1 to 12, wherein:
the bottom surface includes:

a lower end surface portion that is a flat portion located at a lower end of the housing;

a common surface portion (32B) that is a flat portion located at a fixed position in the vertical direction of the housing regardless of a width of the at least one tape mounted in the tape housing area, that is located at a higher position than the lower end surface portion, and that extends parallel to the lower end surface portion; and

a reference surface portion (68C) that is a flat portion located at a higher position than the common surface portion in the vertical direction and that extends parallel to the common surface portion;

a pair of corner portions (32A) adjacent to the tape housing area on the rear edge side is a pair of common height portions each including the common surface portion;

the color indicator portion is provided in the reference surface portion disposed between the pair of common height portions; and

the protrusion protrudes downward from the reference surface portion.

[Claim 14]

A tape printer (1), comprising:

a tape cassette (30) that includes:

a housing (31) including a top wall (31A) having a top surface, a bottom wall (31B) having a bottom surface, and a side wall (31C), the top wall and the bottom wall having a rectangular shape whose longitudinal direction is a left-and-right direction of the housing, the top wall, the bottom wall, and the side wall defining a periphery of the housing;

at least one tape (55, 57, 58, 59) mounted in a tape housing area (33A and 33B) defined within the periphery; and

a color indicator portion (900) disposed between the tape housing area and the periphery, and in a specified area (R0) adjacent to the tape housing area on a rear edge side of the bottom wall, the color indicator portion indicating color information relating to the at least one tape and including a plurality of lateral information sections (Y1 and Y2), the plurality of lateral information sections being a plurality of strip-shaped sections extending along the left-and-right direction of the housing and aligned in a front-rear direction of the housing,

a cassette housing portion (8) in which the tape cassette is detachably installed;

a feeding device (23 and 100) that feeds the at least one tape along a predetermined feed path from the housing of the tape cassette installed in the cassette housing portion;

a printing device (10) that performs printing on a print medium tape (55, 57, 59) fed by the feeding device, the print medium tape being one of the at least one tape;

a plurality of detecting switches (310) that protrude toward the bottom surface of the housing of the tape cassette installed in the cassette housing portion, and that detects identification information for identifying the color information relating to the at least one tape mounted in the housing;

a table storage device (402) that stores a color information table (520) in which the identification information is associated with the color information; and

a color identifying device (401) that identifies, with reference to the color information table, the color information associated with the identification information detected by the plurality of detecting switches as the color information relating to the at least one tape mounted in the housing,

wherein:

a presence or an absence of a first protrusion (902) that protrudes downward from the bottom surface and is formed in a first lateral information section (Y1) indicates, as the color information, a base material color of the at least one tape, the first lateral information section being one of the plurality of lateral information sections and adjoining the rear edge of the bottom wall.

when the tape cassette is installed in the cassette housing portion, the plurality of detecting switches detects information indicating one of a pressed state and a non-pressed state of each of the plurality of detecting switches as the identification information; and

the color identifying device identifies, as the color information, the base material color associated with the identification information detected by the plurality of detecting switches.

[Claim 15]

The tape printer according to claim 14, wherein:

a presence or an absence of a second protrusion (902) that protrudes downward from the bottom surface and is formed in a second lateral information section (Y2) indicates, as the color information, a print color of the at least one tape, the second lateral information section being

another of the plurality of lateral information sections and located to the front of the first lateral information section; and
the color identifying device identifies, as the color information, the print color associated with the identification information detected by the plurality of detecting switches.

[Claim 16]

The tape printer according to claim 15, wherein:

the plurality of detecting switches include a first area detecting switch (310A to 310D) that opposes the first lateral information section when the tape cassette is installed in the cassette housing portion, and a second area detecting switch (310E) that opposes the second lateral information section;

the first area detecting switch is selectively pressed by the protrusion formed in the first lateral information section to thereby detect first area information as the identification information;

the second area detecting switch is selectively pressed by the protrusion formed in the second lateral information section to thereby detect second area information as the identification information; and

the color identifying device identifies, with reference to the color information table, the base material color associated with the first area information detected by the first area detecting switch, and the print color associated with the second area information detected by the second area detecting switch.

[Claim 17]

The tape printer according to claim 16, wherein:

if the color indicator portion indicates a special color as the base material color, the protrusion is formed in a specified position of the first lateral information section and

if the first area information indicates a pressed state of the first area detecting switch that opposes the specified position and a non-pressed state of the first area detecting switch that does not oppose the specified position, the color identifying device at least identifies, as the color information, that the base material color is the special color.

[Claim 18]

The tape printer according to claim 16 or 17, wherein:

if the protrusion is not formed in the second lateral information section, the color indicator portion indicates that the print color is black;

if the protrusion is formed in the second lateral information section, the color indicator portion indicates that the print color is a color other than black;

if the second area information indicates the non-pressed state of the

- second area detecting switch, the color identifying device at least identifies, as the color information, that the print color is black; and if the second area information indicates the pressed state of the second area detecting switch, the color identifying device at least identifies, as the color information, that the print color is the color other than black.
- [Claim 19] Tape printer according to any one of claims 15 to 18, wherein: the tape cassette includes an ink ribbon (60) mounted in an ink ribbon housing area (33C) defined within the periphery of the housing; and the print color is an ink color of the ink ribbon.
- [Claim 20] The tape printer according to any one of claims 15 to 18, wherein: the at least one tape includes a heat-sensitive color development tape (55); and the print color is a color developed by the heat-sensitive color development tape.
- [Claim 21] The tape printer according to any one of claims 15 to 20, wherein: the tape housing area includes a first tape housing area (33A) and a second tape housing area (33B), the first and second tape housing areas each having a generally circular shape in a plan view, the first and second tape housing areas being aligned with each other in the left-and-right direction such that outer peripheral edges of the first and second tape housing areas contact with each other; the at least one tape (55, 57, 58, 59) is wound and mounted in at least one of the first and second tape housing areas; the color indicator portion includes a reference vertical information section (X3) that is a strip-shaped section extending along the front-rear direction of the housing and that includes a reference line (Z), the reference line being an imaginary line extending along the front-rear direction and passing through a contact point (P) of the outer peripheral edges of the first and second tape housing areas; and the protrusion provided in at least one of the first and second lateral information sections is provided at least in the reference vertical information section; and the plurality of detecting switches includes at least two detecting switches that correspond to two areas where the reference vertical information section intersects and overlaps with the first lateral information section and the second lateral information section, respectively.
- [Claim 22] The tape printer according to claim 21, wherein:

the color indicator portion includes a plurality of vertical information sections (X1 to X4) that are a plurality of strip-shaped sections extending along the front-rear direction of the housing and aligned in the left-and-right direction of the housing;

the plurality of vertical information sections includes the reference vertical information section and a subordinate vertical information section (X1, X2, X4) arranged in parallel with the reference vertical information section; and

the protrusion provided in at least one of the first lateral information section and the second lateral information section is provided in at least one of the reference vertical information section and the subordinate vertical information section; and

each of the plurality of detecting switches is provided corresponding to one of a plurality of areas where the plurality of vertical information sections intersects and overlaps with the first lateral information section and the second lateral information section respectively.

[Claim 23]

The tape printer according to any one of claims 14 to 22, wherein:

the bottom surface of the housing includes:

a lower end surface portion that is a flat portion located at a lower end of the housing;

a common surface portion (32B) that is a flat portion located at a fixed position higher than the lower end surface portion in the vertical direction of the housing, regardless of a width of the at least one tape mounted in the tape housing area, and that extends parallel to the lower end surface portion; and

a reference surface portion that is a flat portion located at a higher position than the common surface portion in the vertical direction and that extends parallel to the common surface portion;

a pair of corner portions adjacent to the tape housing area on the rear edge side is a pair of common height portions each including the common surface portion;

the color indicator portion is provided in the reference surface portion disposed between the pair of common height portions; and

the protrusion protrudes downward from the reference surface portion.

[Fig. 1]

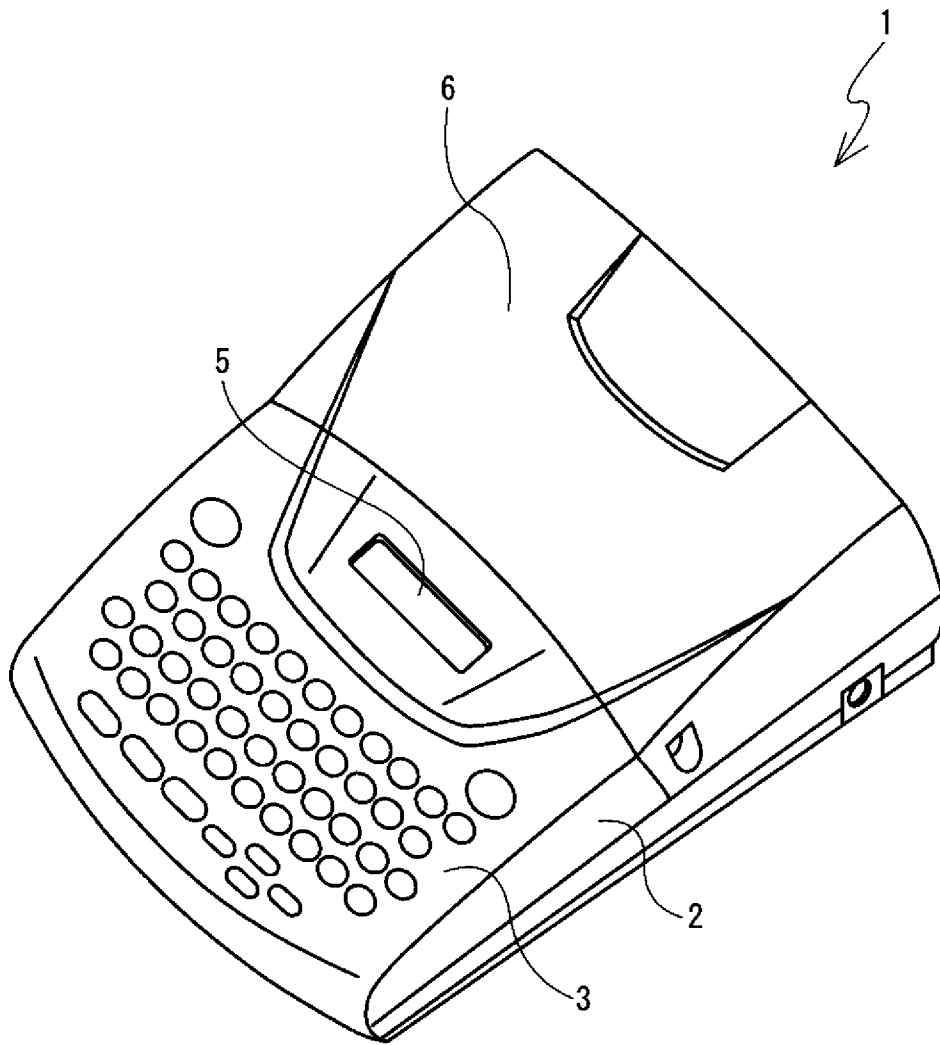

[Fig. 2]

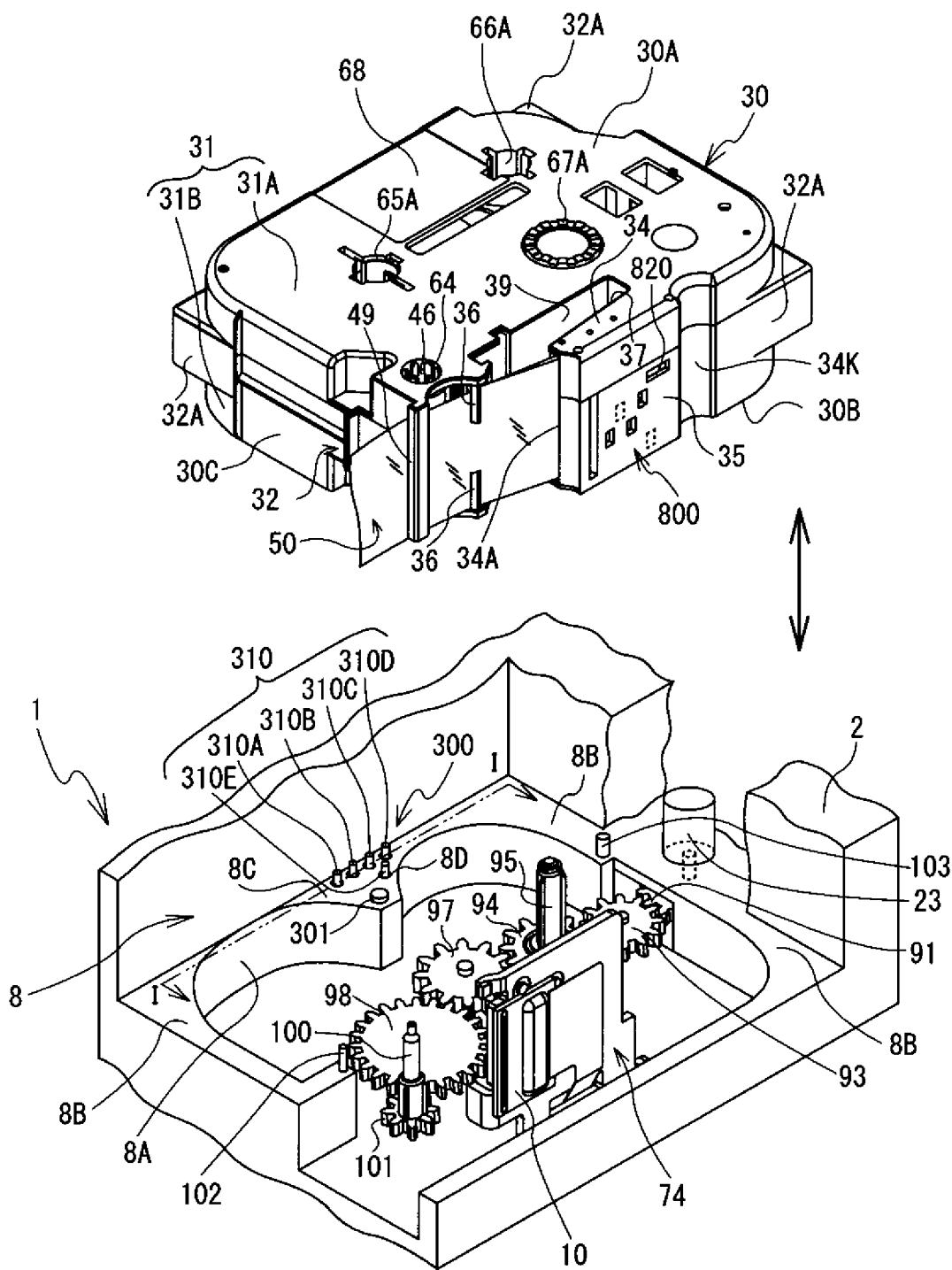

[Fig. 3]

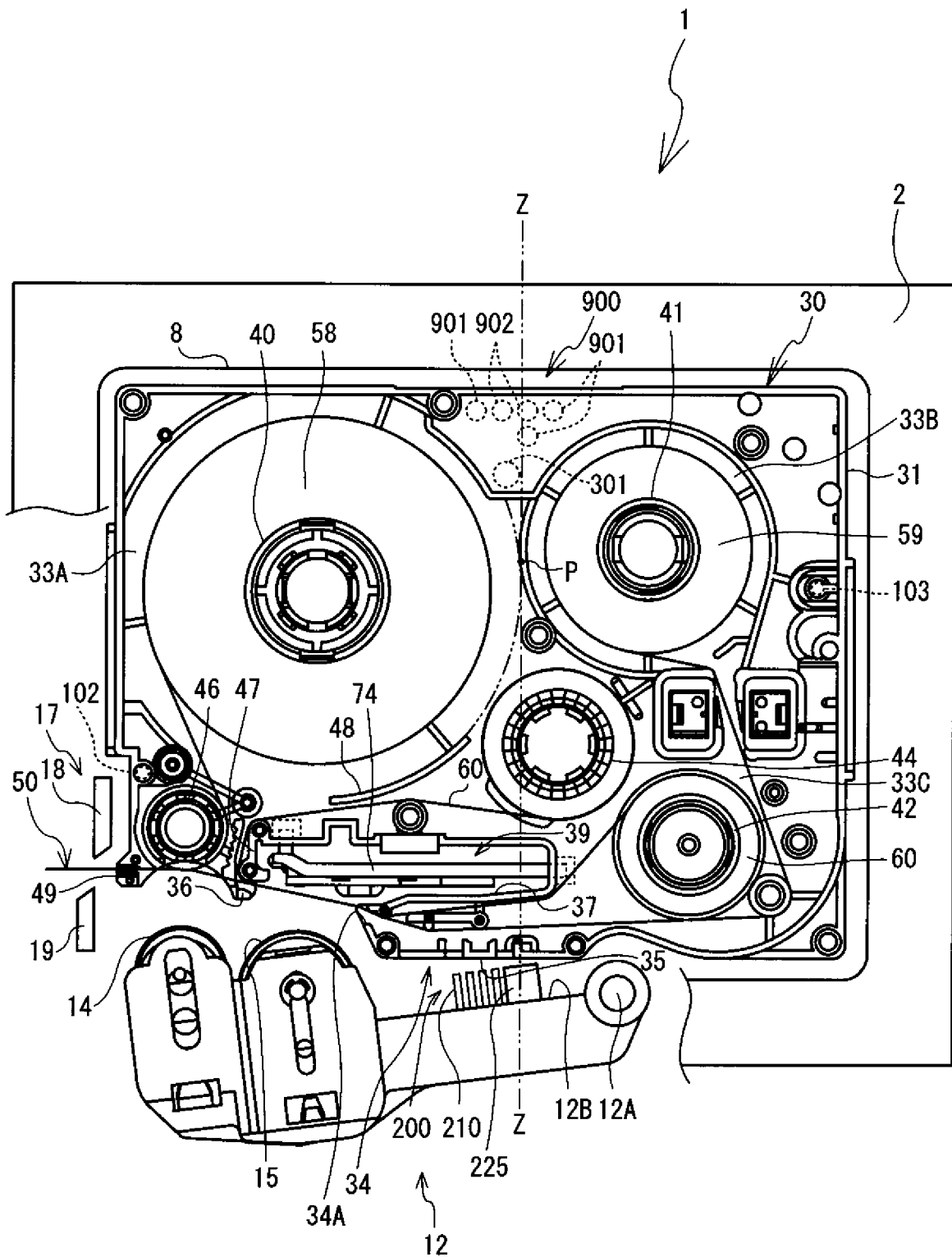

[Fig. 4]

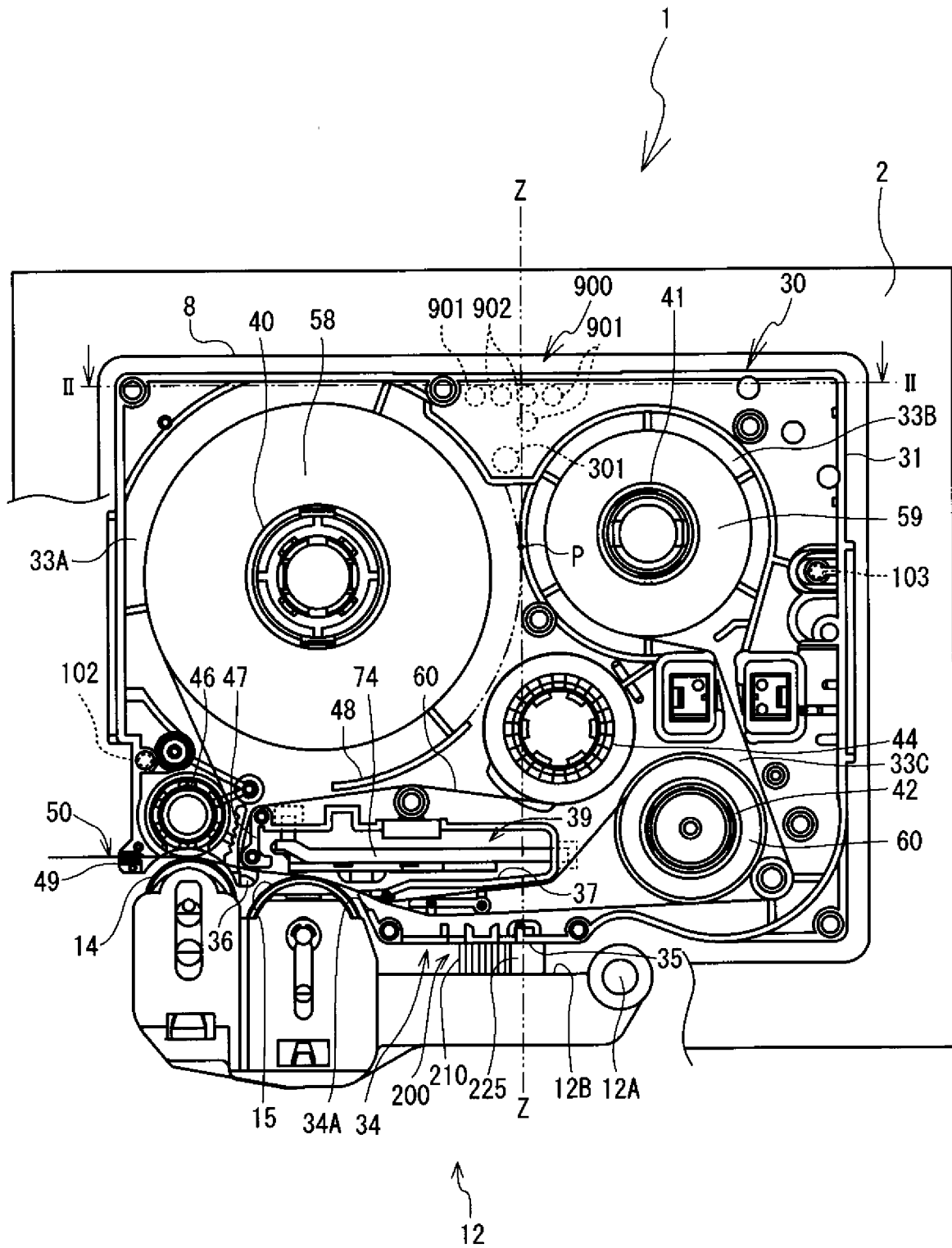

[Fig. 5]

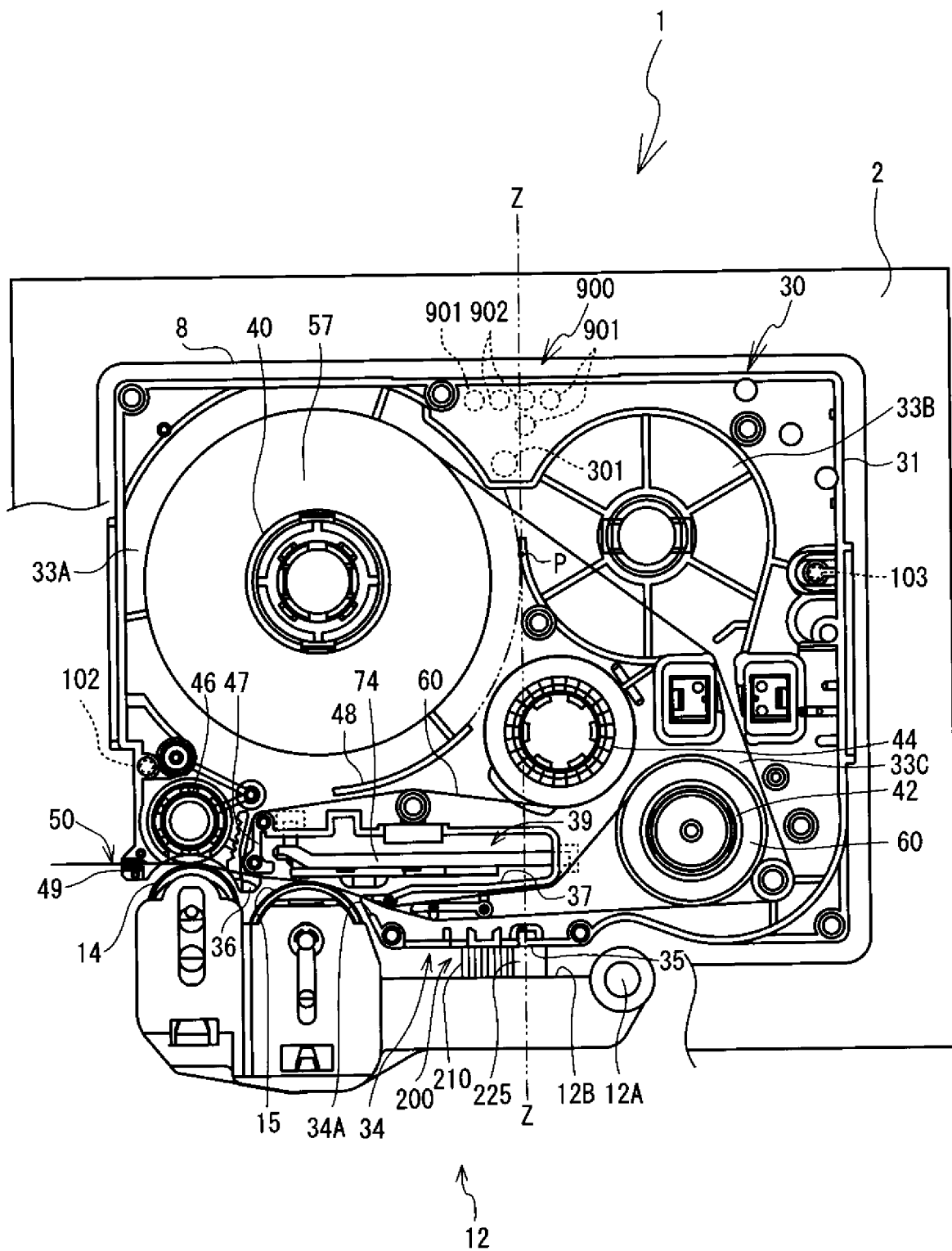

[Fig. 6]

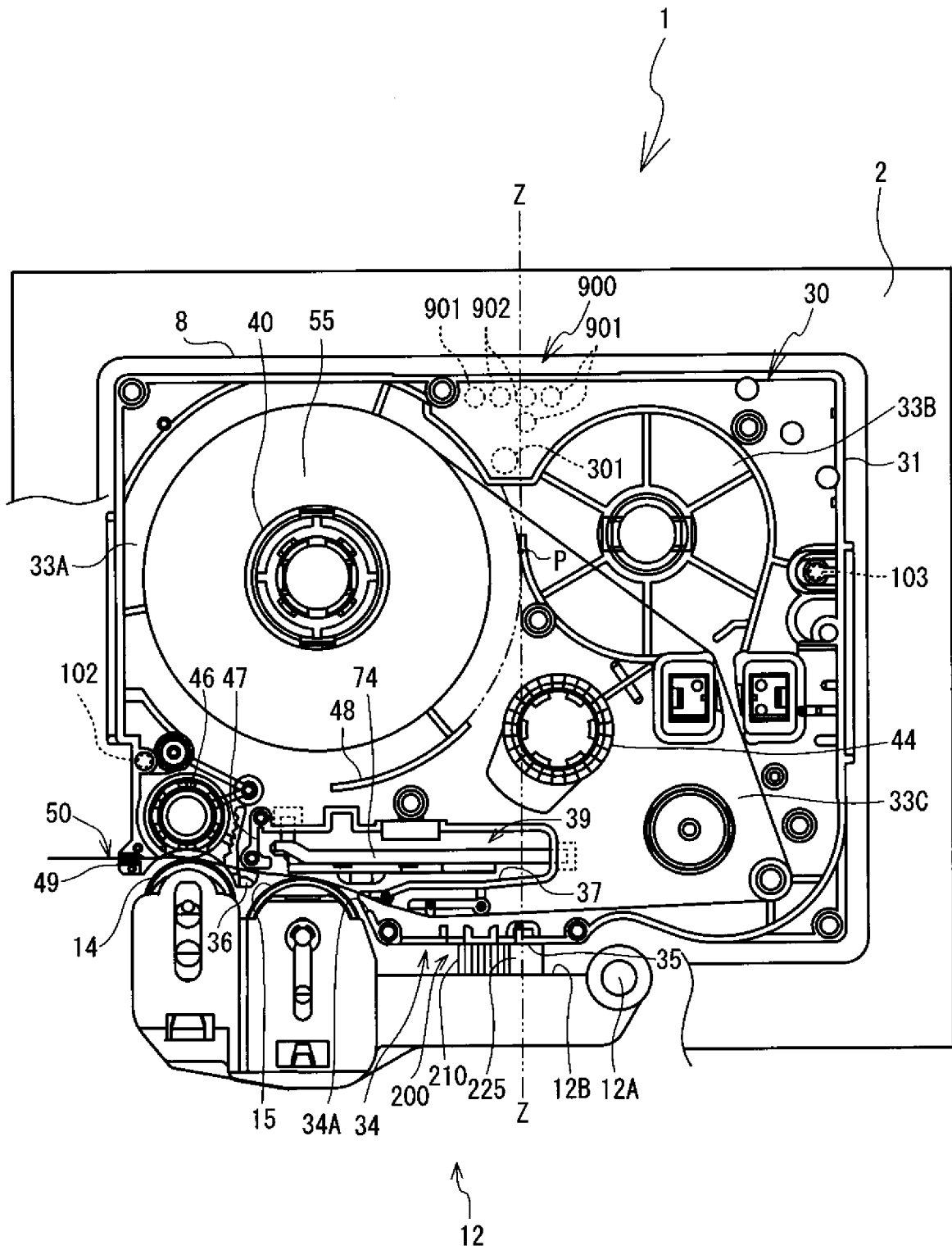

[Fig. 7]

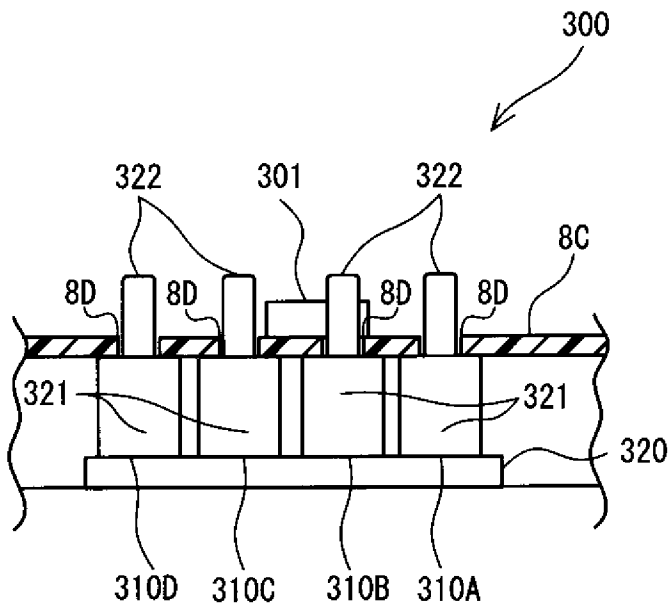

[Fig. 8]

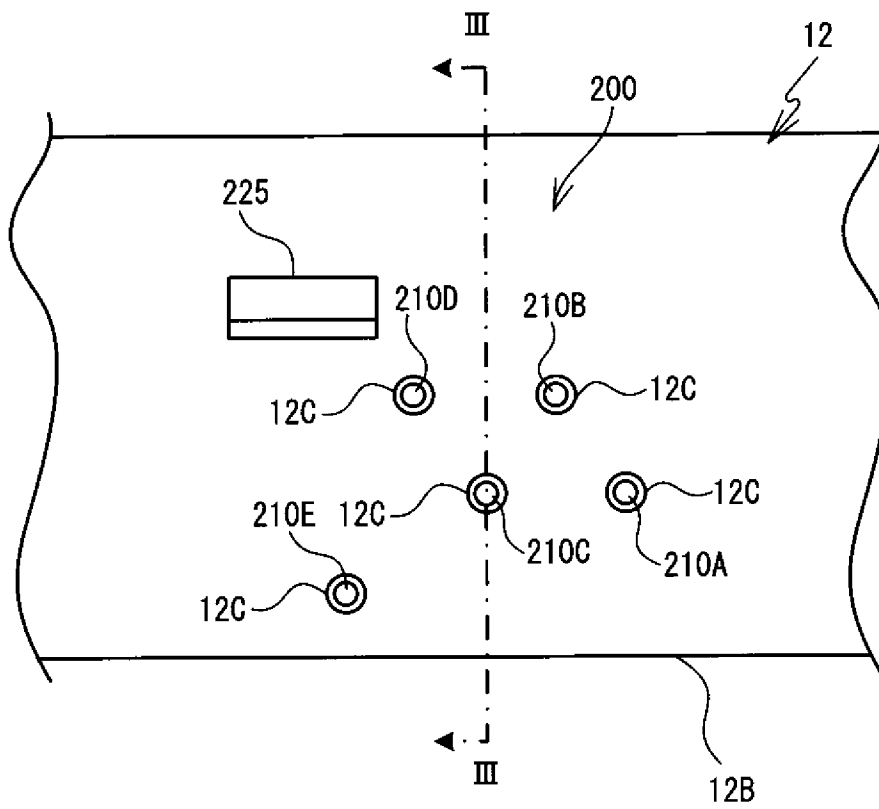

[Fig. 9]

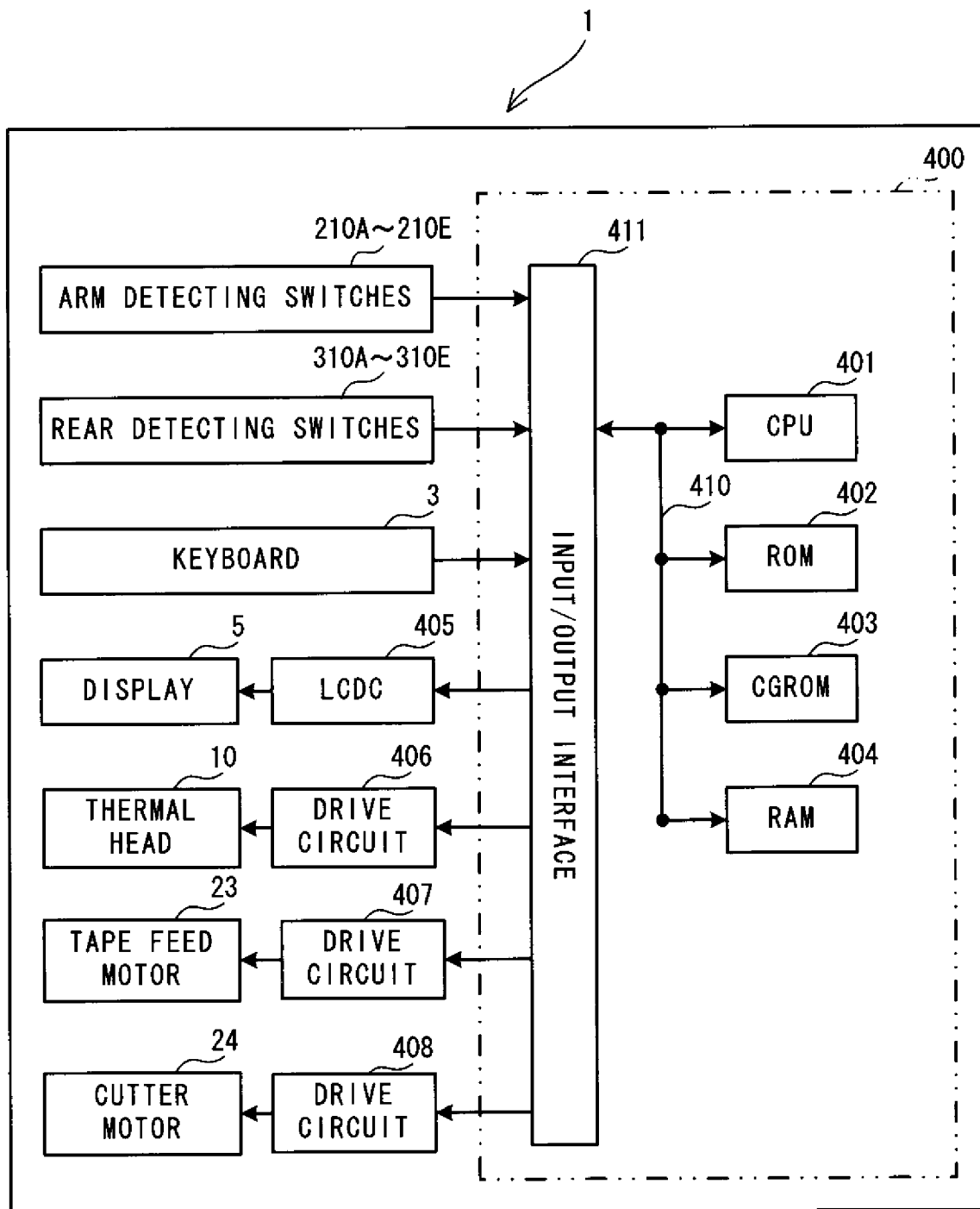

[Fig. 12]

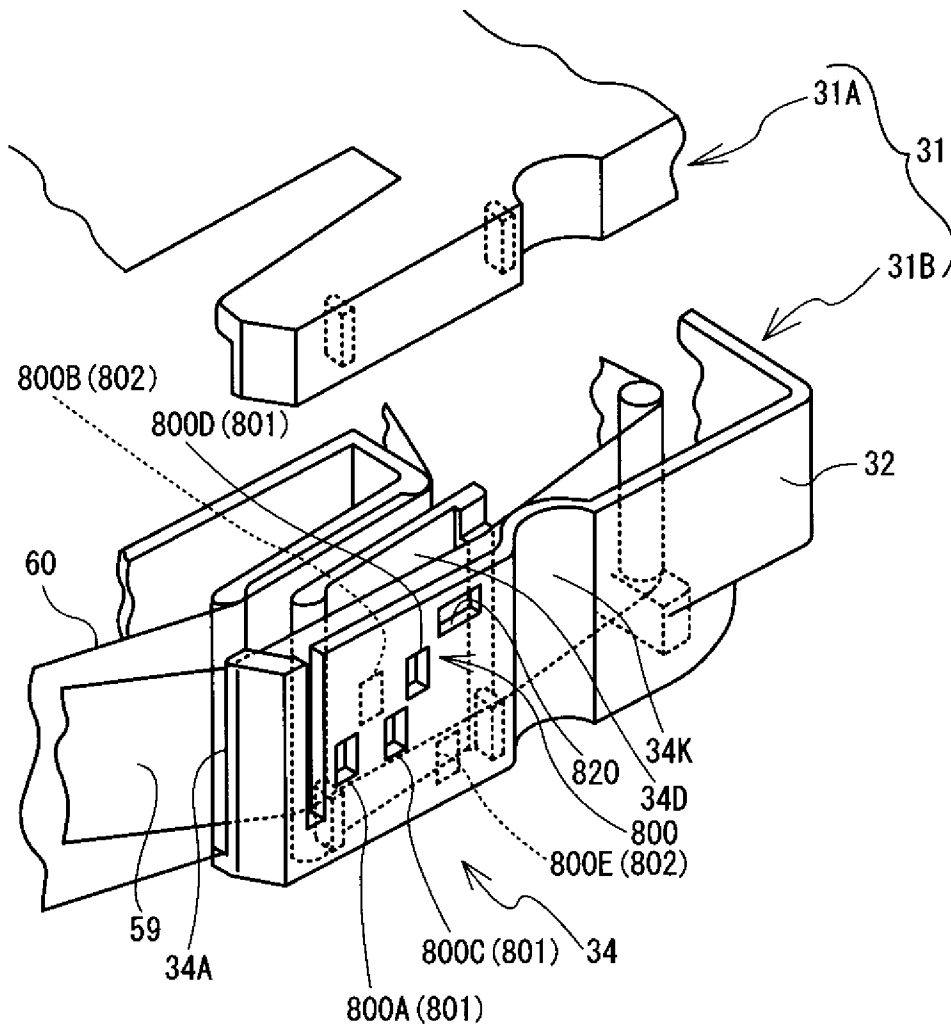

[Fig. 13]

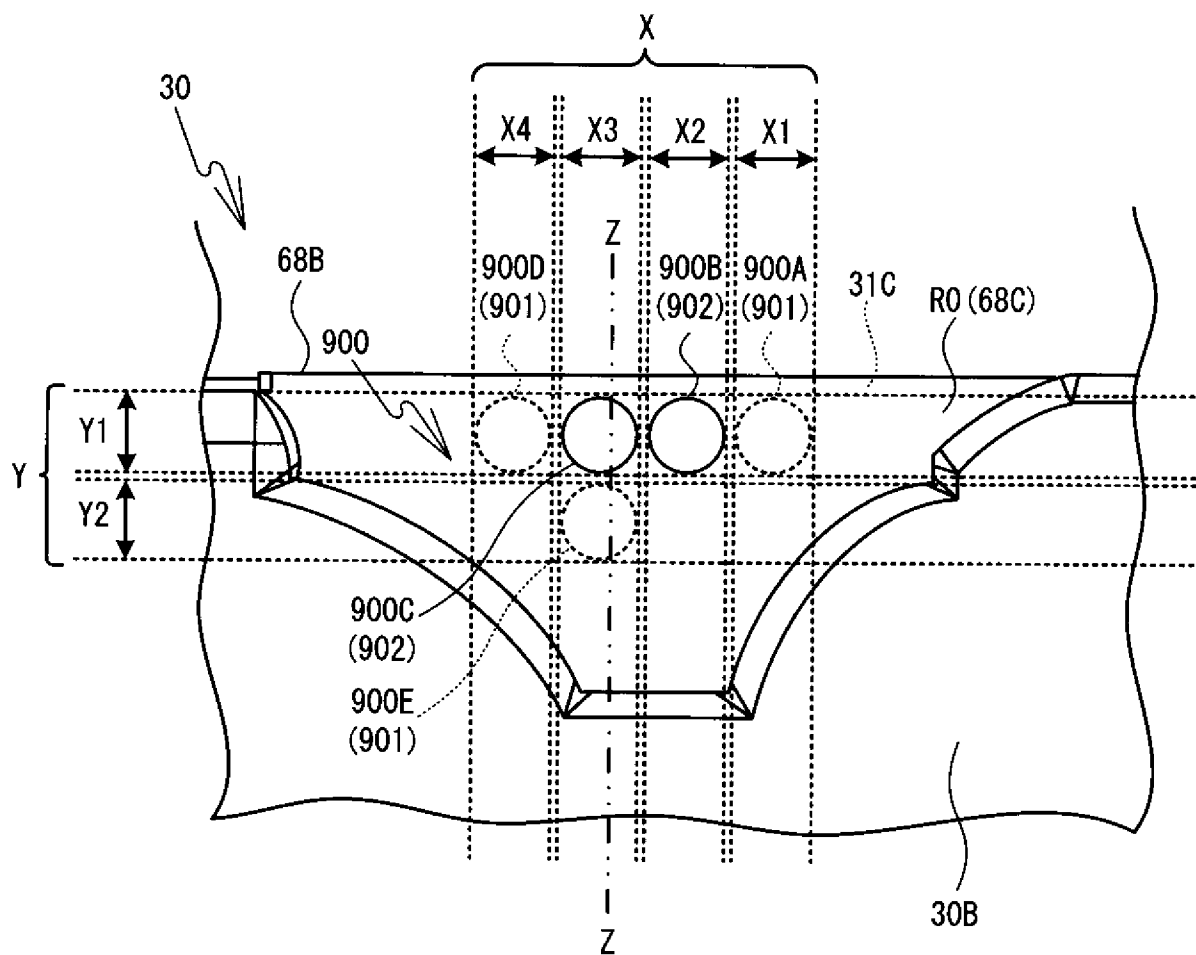

[Fig. 14]

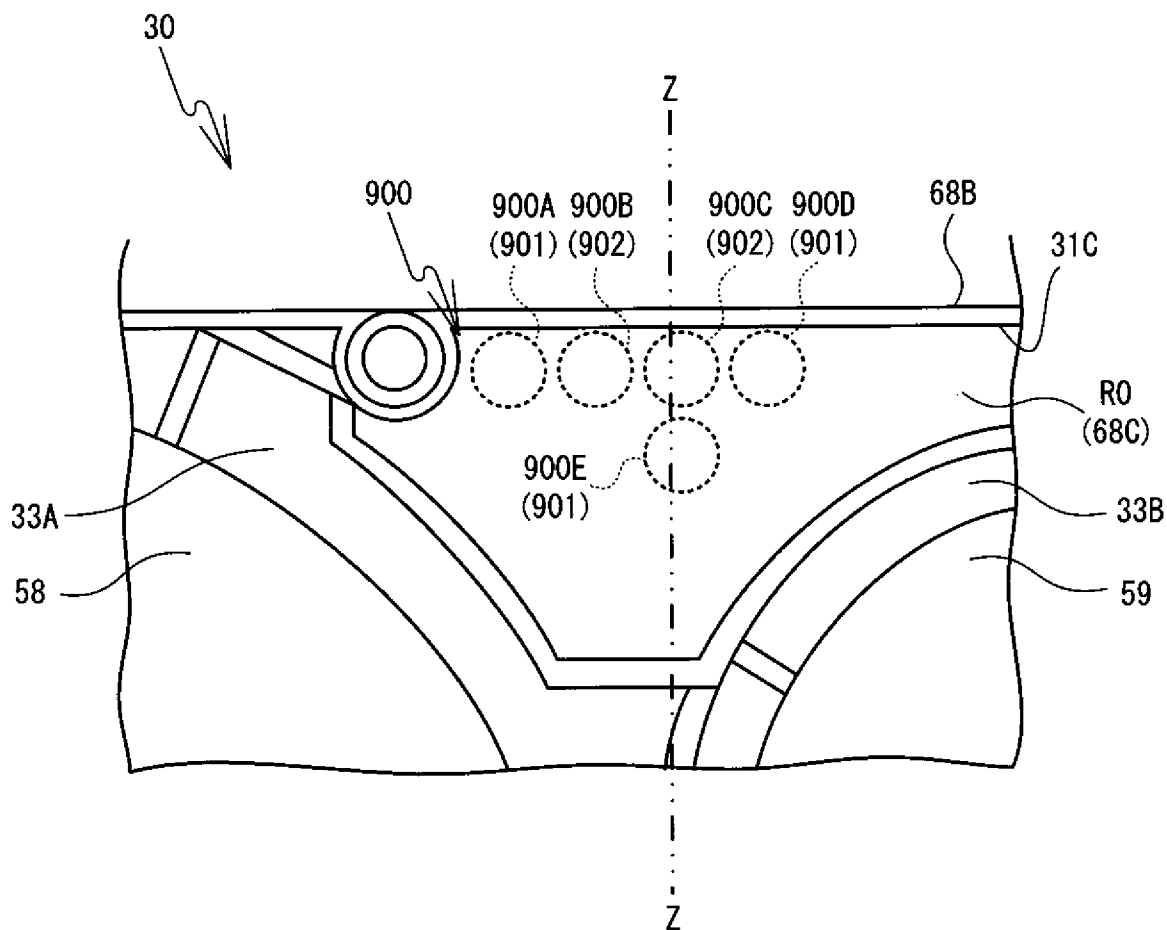

[Fig. 15]

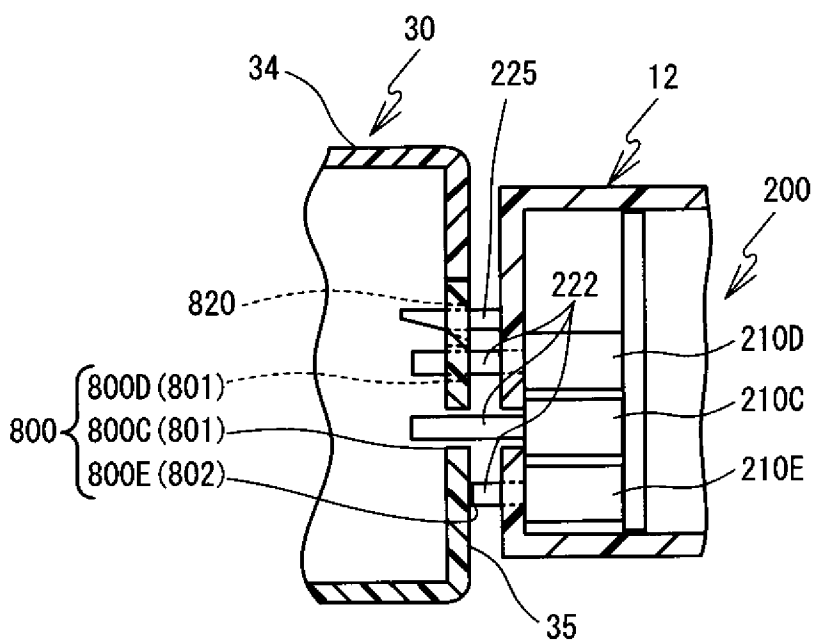

[Fig. 16]

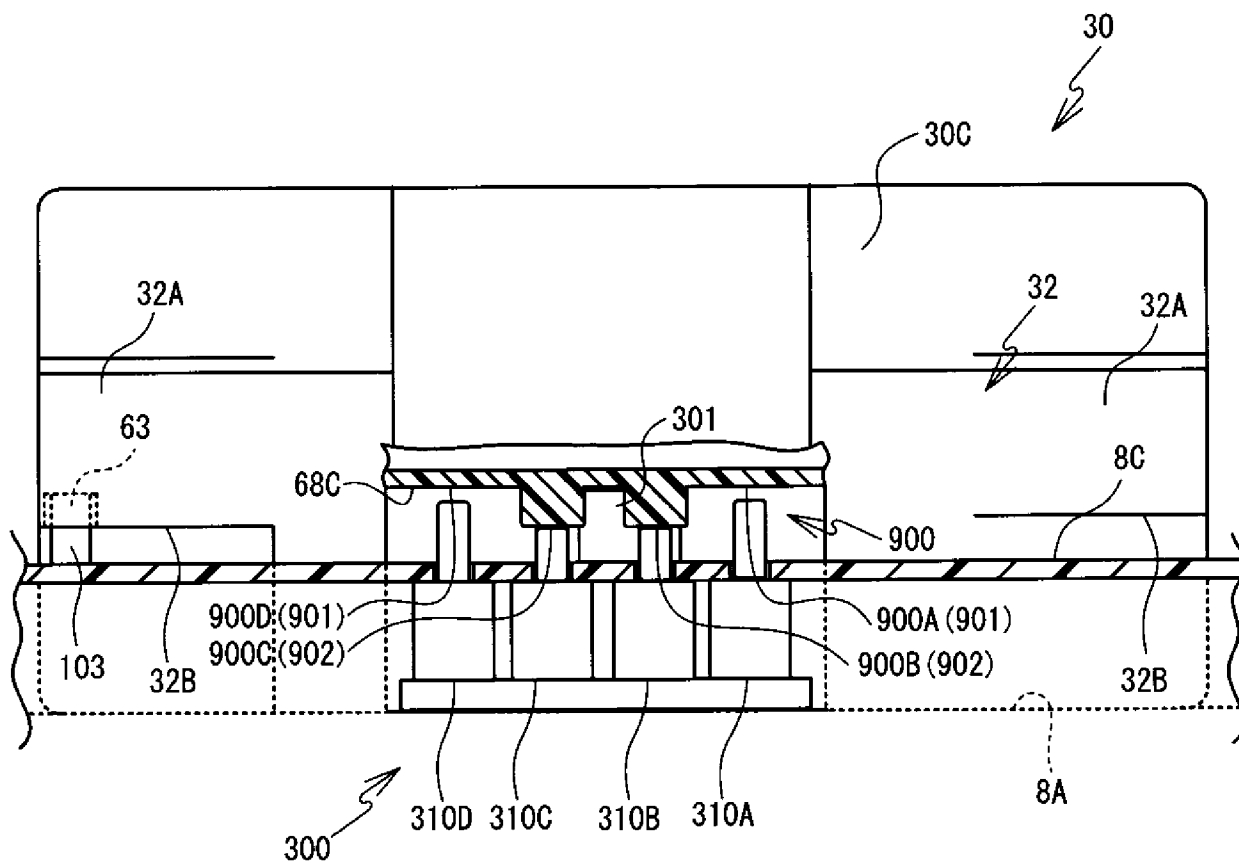

[Fig. 17]

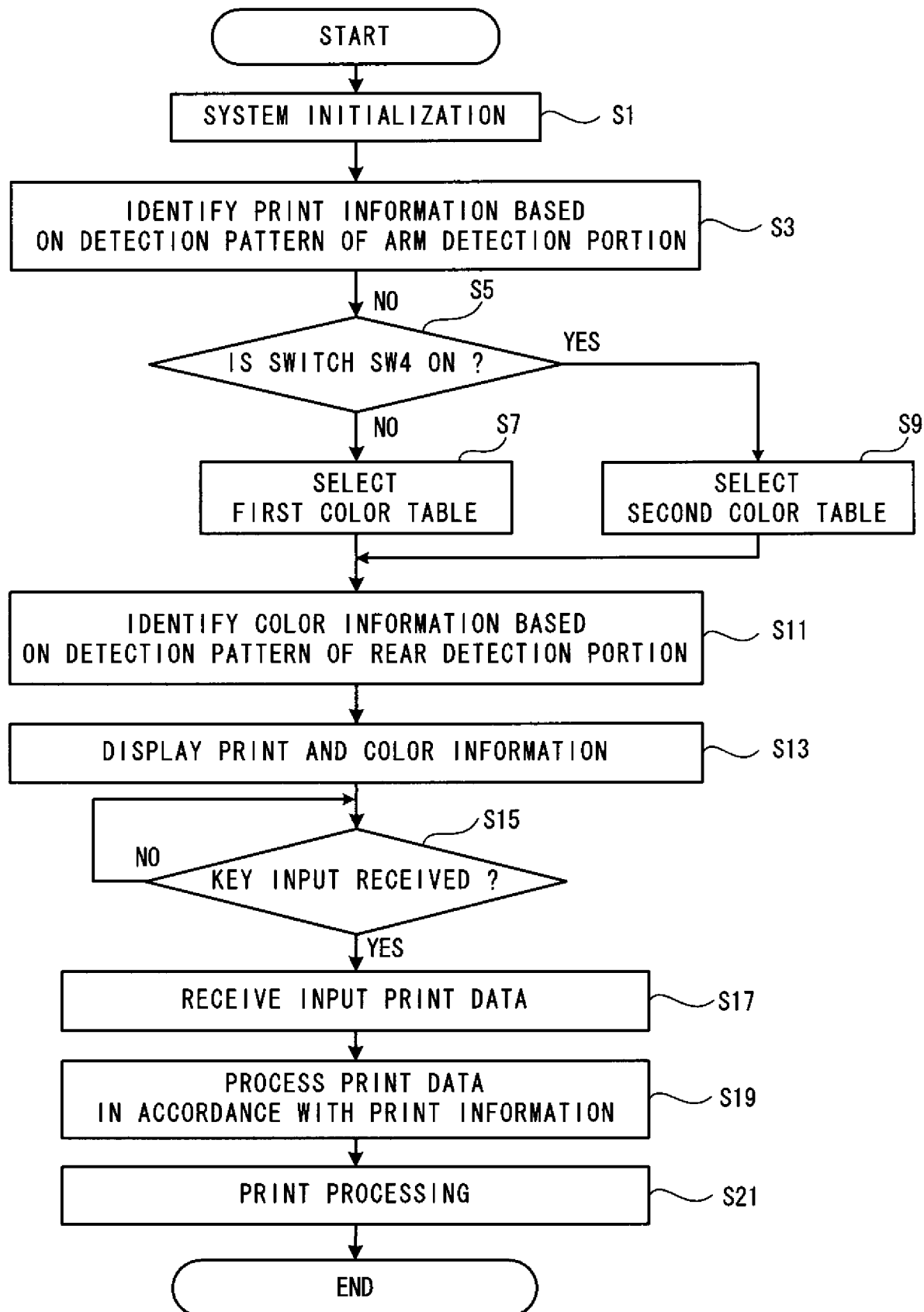

[Fig. 18]

520

521

522

	ST1	ST2	ST3	ST4	ST5	FIRST COLOR TABLE		SECOND COLOR TABLE	
						TAPE COLOR	INK COLOR	TAPE COLOR	INK COLOR
0	0	1	1	1	0	White	Black	Mat white	Black
1	0	1	1	0	0	Clear	Black	Mat Clear	Black
2	1	0	1	0	0	Yellow	Black	SPARE	Black
3	0	0	1	1	0	Blue	Black	SPARE	Black
4	0	1	0	1	0	Red	Black	SPARE	Black
5	1	0	1	1	0	Green	Black	SPARE	Black
6	1	1	1	0	0	Flu. Orange	Black	SPARE	Black
7	0	1	0	0	0	Flu. Yellow	Black	SPARE	Black
8	1	0	0	1	0	Mat Silver	Black	Silver	Black
9	1	0	0	0	0	Flu. Green	Black	SPARE	Black
10	1	1	0	0	0	Gold	Black	SPARE	Black
11	0	0	0	1	0	SPARE	Black	SPARE	Black
12	0	0	1	0	0	SPARE	Black	SPARE	Black
13	1	1	1	1	0	SPARE	Black	SPARE	Black
14	1	1	0	1	0	SPARE	Black	SPARE	Black
15	0	0	0	0	0	ERROR		ERROR	
16	0	1	1	1	1	White	Blue	White	Red
17	0	1	1	0	1	Clear	Blue	Clear	Red
18	1	0	1	0	1	Yellow	Blue	SPARE	SPARE
19	0	0	1	1	1	Blue	Blue	Mat Silver	Gold
20	0	1	0	0	1	Pink	Blue	Pink	Red
21	1	0	1	1	1	Blue	White	Mat Gray	White
22	1	1	1	0	1	Clear	White	Mat Green	White
23	0	1	0	1	1	Red	White	Mat Pink	White
24	0	0	0	1	1	Black	White	Mat Gold	White
25	1	0	0	1	1	Black	Gold	Mat Silver	Red
26	1	0	0	0	1	SPARE	SPARE	COLOR 1	
27	1	1	0	0	1	SPARE	SPARE	COLOR 2	
28	0	0	1	0	1	SPARE	SPARE	COLOR 3	
29	0	0	0	0	1	SPARE	SPARE	SPARE	SPARE
30	1	1	1	1	1	SPARE	SPARE	SPARE	SPARE
31	1	1	0	1	1	ERROR		ERROR	

[Fig. 19]

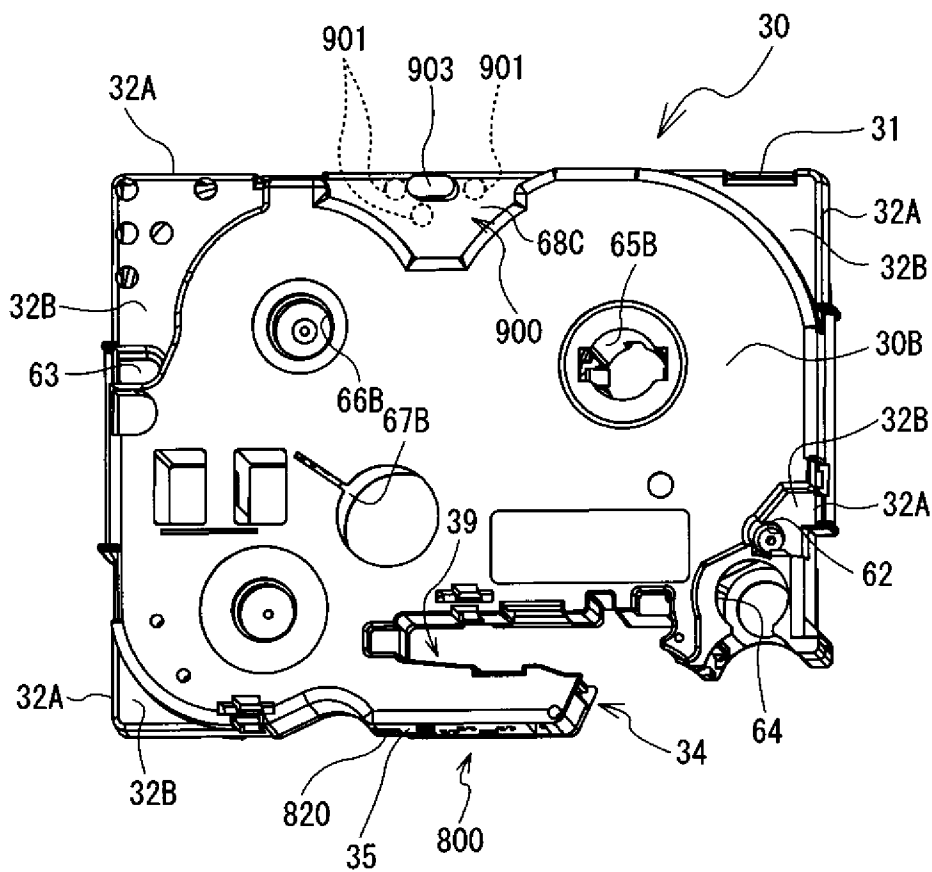

[Fig. 20]

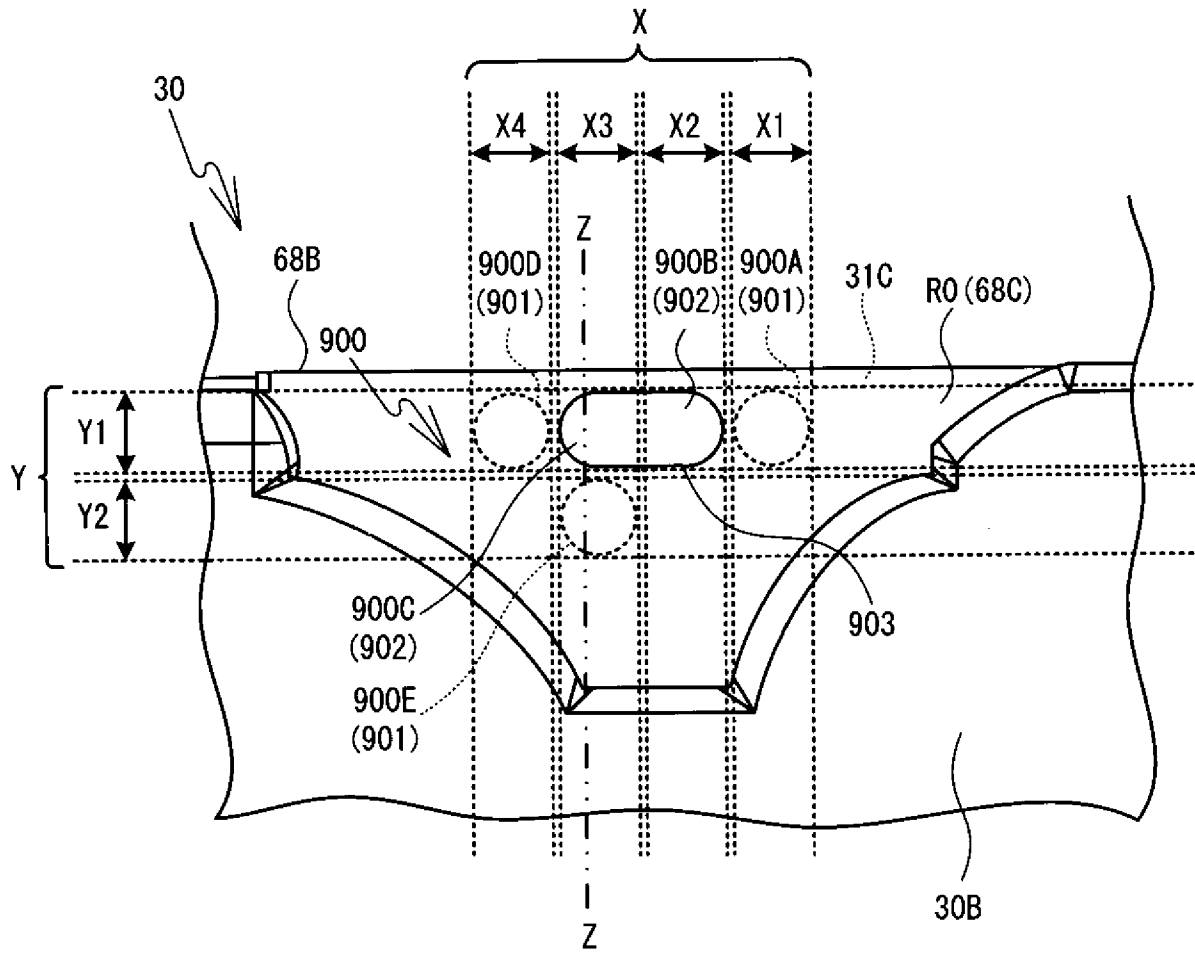

INTERNATIONAL SEARCH REPORT

International application No
PCT/JP2010/002161

A. CLASSIFICATION OF SUBJECT MATTER
INV. B41J11/00 B41J15/04
ADD.

According to International Patent Classification (IPC) or to both national classification and IPC

B. FIELDS SEARCHED

Minimum documentation searched (classification system followed by classification symbols)
B41J

Documentation searched other than minimum documentation to the extent that such documents are included in the fields searched

Electronic data base consulted during the international search (name of data base and, where practical, search terms used)

EPO-Internal

C. DOCUMENTS CONSIDERED TO BE RELEVANT

Category*	Citation of document, with indication, where appropriate, of the relevant passages	Relevant to claim No.
X	<p>US 5 538 352 A (SUGIURA KAZUHIKO [JP]) 23 July 1996 (1996-07-23)</p> <p>column 8, line 14 - line 25; figures 4B,4C column 9, paragraph 2</p> <p style="text-align: center;">-----</p>	<p>1-7, 10-12, 14-20</p>

Further documents are listed in the continuation of Box C.

See patent family annex.

* Special categories of cited documents :

A document defining the general state of the art which is not considered to be of particular relevance

E earlier document but published on or after the international filing date

L document which may throw doubts on priority claim(s) or which is cited to establish the publication date of another citation or other special reason (as specified)

O document referring to an oral disclosure, use, exhibition or other means

P document published prior to the international filing date but later than the priority date claimed

T later document published after the international filing date or priority date and not in conflict with the application but cited to understand the principle or theory underlying the invention

X document of particular relevance; the claimed invention cannot be considered novel or cannot be considered to involve an inventive step when the document is taken alone

Y document of particular relevance; the claimed invention cannot be considered to involve an inventive step when the document is combined with one or more other such documents, such combination being obvious to a person skilled in the art.

& document member of the same patent family

Date of the actual completion of the international search

15 July 2010

Date of mailing of the international search report

03/08/2010

Name and mailing address of the ISA/

European Patent Office, P.B. 5818 Patentlaan 2
NL - 2280 HV Rijswijk
Tel. (+31-70) 340-2040,
Fax: (+31-70) 340-3016

Authorized officer

Wehr, Wolfhard

INTERNATIONAL SEARCH REPORT

Information on patent family members

International application No

PCT/JP2010/002161

Patent document cited in search report	Publication date	Patent family member(s)	Publication date
US 5538352	A	23-07-1996	
		DE 69417828 D1	20-05-1999
		DE 69417828 T2	23-09-1999
		EP 0644506 A2	22-03-1995
		JP 3378622 B2	17-02-2003
		JP 7089196 A	04-04-1995
