



## INTERNATIONAL APPLICATION PUBLISHED UNDER THE PATENT COOPERATION TREATY (PCT)

(51) International Patent Classification <sup>5</sup> : <b>A61N 5/01</b>	<b>A2</b>	(11) International Publication Number: <b>WO 94/28971</b> (43) International Publication Date: 22 December 1994 (22.12.94)
<p>(21) International Application Number: PCT/US94/06488</p> <p>(22) International Filing Date: 8 June 1994 (08.06.94)</p> <p>(30) Priority Data: 08/071,741 9 June 1993 (09.06.93) US 08/071,742 9 June 1993 (09.06.93) US</p> <p>(71) Applicant: WISCONSIN ALUMNI RESEARCH FOUNDATION [US/US]; Floor 13, 614 Walnut Street, Madison, WI 53707-7365 (US).</p> <p>(72) Inventors: SWERDLOFF, Stuart; 2309 Upham Street, Madison, WI 53704 (US). MACKIE, Thomas, Rockwell; 2310 Ravenswood Road, Madison, WI 53711 (US). HOLMES, Timothy; 18 Oak Glen Court, Madison, WI 53717 (US).</p> <p>(74) Agents: BAXTER, Keith, M. et al.; Quarles &amp; Brady, Suite 2550, 411 East Wisconsin Avenue, Milwaukee, WI 53202-4477 (US).</p>		<p>(81) Designated States: CA, JP, European patent (AT, BE, CH, DE, DK, ES, FR, GB, GR, IE, IT, LU, MC, NL, PT, SE).</p> <p><b>Published</b> <i>Without international search report and to be republished upon receipt of that report.</i></p>

(54) Title: RADIATION THERAPY SYSTEM

## (57) Abstract

A radiation therapy machine having constrained angular freedom to produce a beam only within a gantry plane. A radiation shield may be stationary and not attached to the gantry or rotating to always block the primary beam. The constrained motion reduces the risk of patient/gantry collision and provides for extremely accurate radiation therapy planning. The therapy machine, so constrained, may include a tomographic imaging system on a single gantry. The two systems cooperate and employ many of the same hardware components to both plan and carry out therapy sessions in which irregularly shaped treatment volumes are accurately irradiated while tissue surrounding those volumes is minimally irradiated. The therapy machine also may include a collimator that changes the width of a fan beam of radiation as a treatment volume of the patient crosses the volume exposed by the beam so as to minimize the irradiation of healthy tissue at the front and back of the tumor. The width of the fan beam may be controlled to treat multiple adjacent, similar slices of the patient at one time reducing the treatment duration.

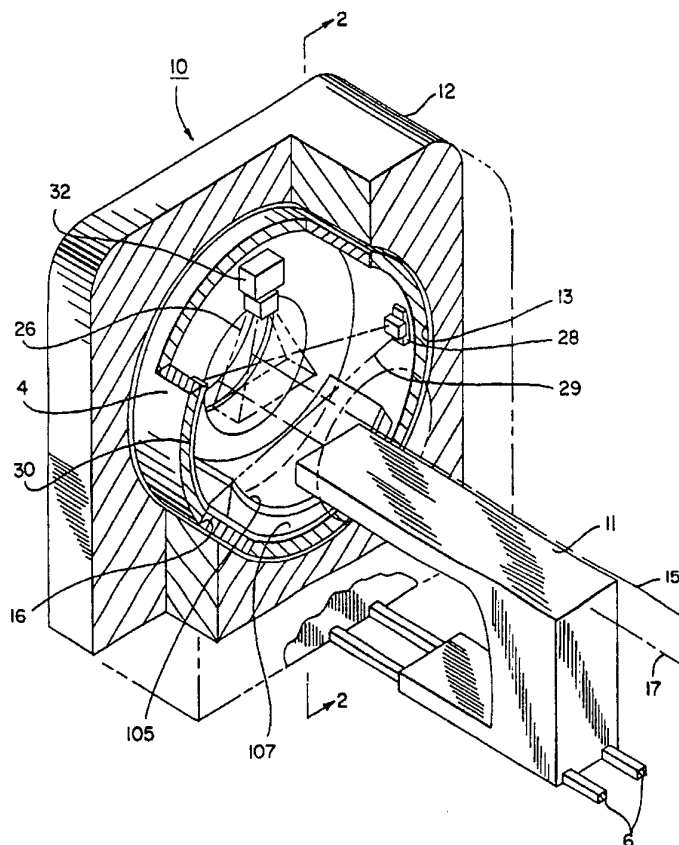

**FOR THE PURPOSES OF INFORMATION ONLY**

Codes used to identify States party to the PCT on the front pages of pamphlets publishing international applications under the PCT.

AT	Austria	GB	United Kingdom	MR	Mauritania
AU	Australia	GE	Georgia	MW	Malawi
BB	Barbados	GN	Guinea	NE	Niger
BE	Belgium	GR	Greece	NL	Netherlands
BF	Burkina Faso	HU	Hungary	NO	Norway
BG	Bulgaria	IE	Ireland	NZ	New Zealand
BJ	Benin	IT	Italy	PL	Poland
BR	Brazil	JP	Japan	PT	Portugal
BY	Belarus	KE	Kenya	RO	Romania
CA	Canada	KG	Kyrgystan	RU	Russian Federation
CF	Central African Republic	KP	Democratic People's Republic of Korea	SD	Sudan
CG	Congo	KR	Republic of Korea	SE	Sweden
CH	Switzerland	KZ	Kazakhstan	SI	Slovenia
CI	Côte d'Ivoire	LI	Liechtenstein	SK	Slovakia
CM	Cameroon	LU	Luxembourg	SN	Senegal
CN	China	LV	Latvia	TD	Chad
CS	Czechoslovakia	LU	Luxembourg	TG	Togo
CZ	Czech Republic	LV	Latvia	TJ	Tajikistan
DE	Germany	MC	Monaco	TT	Trinidad and Tobago
DK	Denmark	MD	Republic of Moldova	UA	Ukraine
ES	Spain	MG	Madagascar	US	United States of America
FI	Finland	ML	Mali	UZ	Uzbekistan
FR	France	MN	Mongolia	VN	Viet Nam
GA	Gabon				

## RADIATION THERAPY SYSTEM

BACKGROUNDField Of The Invention

This invention relates generally to radiation therapy equipment for the treatment of tumors, or the like, and specifically to a radiation therapy machine having reduced freedom of angular rotation. This invention also relates to a collimator for use with a radiation therapy machine, the collimator used for changing the width of a fan beam so as to shorten the time required for a radiation therapy session while allowing precise control of the radiation doses received by the patient.

Description Of The Art

Medical equipment for radiation therapy treats tumorous tissue with high energy radiation. The dose and the placement of the dose must be accurately controlled to ensure both that the tumor receives sufficient radiation to be destroyed, and that damage to the surrounding and adjacent non-tumorous tissue is minimized.

External-source radiation therapy uses a radiation source that is external to the patient, typically either a radioisotope, such as  $^{60}\text{Co}$ , or a high energy x-ray source, such as a linear accelerator. The external source produces a collimated radiation beam directed along an axis of radiation toward a tumor site. Although external-source radiation therapy avoids the disadvantages of surgically invasive procedures, it undesirably but necessarily irradiates a significant volume of non-tumorous healthy tissue within the path of the radiation beam as the beam passes through the patient to the tumor site.

The adverse effect of irradiating healthy tissue may

be reduced, while maintaining a given dose of radiation in the tumorous tissue, by projecting the radiation beam into the patient along a variety of radiation axes with the beams converging on the tumor site. As a radiation  
5 beam is directed along a plurality of radiation axes the particular volume elements of healthy tissue along the path of the radiation beam change, reducing the total dose to each such element of healthy tissue during the entire treatment.

10 Beams may be directed toward a tumor along a variety of radiation axes in three dimensions. By directing the radiation beam toward the tumor site at different angles in three dimensions, the tumor site is "crossfired" from the largest possible number of directions and the  
15 individual voxels of healthy tissue traversed by the radiation beam receive a low dose of radiation.

The irradiation of healthy tissue is also reduced by tightly collimating the radiation beam to the general cross section of the tumor taken perpendicular to the  
20 axis of radiation. Numerous systems exist for producing such a circumferential collimation, some of which use multiple sliding shutters which, piecewise, may generate a radio-opaque mask of arbitrary outline.

In addition to reducing irradiation of healthy  
25 tissue, a tightly collimated beam can minimize the time necessary to complete a therapy session. Thus, a beam may be employed which subtends the entire cross section of a tumor as viewed from the radiation source, as the source is rotated to different angles. In such "thick  
30 beam" systems, irradiation of healthy tissue around a tumor is limited by collimating the radiation beam to the general cross section of the tumor taken perpendicular to the axis of the radiation beam. When using such a collimator with a thick beam, irradiation may be  
35 accomplished at a limited number of angles and therefore therapy sessions can be performed quickly.

The treatment of tumors that are convex in a single

plane may be performed in a simple manner by restricting the different radiation axis of the beam to angles within that plane. For such tumors, a single rotation of the radiation source about a suitable rotation axis can  
5 adequately irradiate the tumor. However, a conventional system constraining the radiation axis to a single plane is inadequate to irradiate tumors that are concave within a rotation plane (which is usually the case).

Thus, multiply articulated radiation sources are  
10 generally preferred because of their unconstrained ability to irradiate tumors from virtually any angle thereby minimizing irradiation of individual voxels of healthy tissue and allowing tumors that are convex in a single plane to be targeted in that plane regardless of  
15 the plane's spatial orientation.

For even more precise dose placement, a multi-articulated radiation source employing slice therapy could be used.

In slice therapy, a collimator is employed between a  
20 radiation source and a patient. The collimator passes a thin fan beam directed @ one slice of the tumor to be irradiated by targeting each tumor slice separately, the radiation delivered within the tumorous area, and to surrounding areas, can be controlled within planes  
25 parallel to the slice plane.

In any system, be it a single plane or a multi-articulated system which employes slice therapy, while thin slices deliver radiation more precisely, as slices are made thinner, more gantry rotations are needed to  
30 irradiate a given tumor. This prolongs the treatment time because the speed of gantry rotation is limited by its fluence which is essentially constant regardless of fan beam width. If gantry rotation speed is increased, the radiation absorbed by the tumor slice is decreased.

In a like manner, an increase in the number of  
35 irradiation angles results in more precise irradiation. However, therapy time necessary to completely irradiate a

tumor increases as the number of radiation angles increase.

The tradeoff between treatment time and precision is illustrated by two polar design approaches for a compensator based system. One design approach would use a thick beam using a circumferential collimator in a single plane. This design would provide fast therapy but large pixels and thus coarse fluence regulation. The second design approach would use a thin beam and a large number of radiation angles and require more time per therapy session producing finer fluence regulation.

Beside being slower, radiation with a multiply articulate machine is more costly as radiation barriers are more complex. In any radiotherapy machine configuration, it is important to limit scattered, uncontrolled radiation in a therapy area. Uncontrolled radiation can scatter off therapy equipment and back into a patient or operator. Radiation scatter from a multiply articulated source requires a protective barrier which is at all times opposed to the radiation source, the patient being disposed between the source and barrier.

Ideally, the primary protective barrier absorbs the unattenuated x-rays passing through the patient. With a multiply articulate source, the primary barrier must be moveable to assume any angle directly opposed to the radiation source.

#### Summary Of The Invention

The present invention provides an improved architecture for radiation therapy equipment in which the motion of the radiation source is constrained to a single plane. This single plane configuration provides a number of benefits over the multiply articulated systems.

Specifically, the present invention employs a gantry rotating within a gantry plane about a table near its axis of rotation. A radiation source is attached to the gantry for directing a radiation beam, including a

plurality of rays, toward the patient during its rotation. A compensator positioned between the radiation source and the patient intercepts the beam and independently controls the intensity of each ray according to a control signal based on the gantry angle and the position of the translation table.

It is a first object of the invention to provide a radiation therapy system that is readily adapted to high accuracy radiation planning techniques. By treating the patient on a slice-by-slice basis with radiation directed at angles within a single plane, and by controlling the intensity of each ray of the radiation as a function of angle, tumors of arbitrary shape can be accurately irradiated.

The gantry and radiation source may be enclosed within a toroidal housing embracing the swept volume of the gantry. This configuration helps ensure that the table or patient or operators remain out of the path of the rotating radiation source. A primary barrier may be positioned for rotation within the gantry diametrically opposed to the radiation source. The primary barrier intercepts and occludes radiation as the radiation exits the patient. The toroidal housing of the gantry may also be constructed with materials providing scatter shielding to be used as a stationary secondary barrier to limit scatter radiation within a therapy area. Because the secondary barrier need not rotate with the radiation source, the secondary barrier may be heavier and more effective.

In one embodiment, the gantry rotates continuously as the tumor is translated along the axis of rotation so that a volume of arbitrary length may be treated. The compensator is controlled as a function of both gantry angle and table position.

It is thus another object of the invention to employ the simplified architecture of the present invention in a manner that provides for smooth irradiation of volumes

extending along the axis of rotation and wider than the radiation beam. As will be described in detail below, the resultant helical path of the changing radiation axis produced by the continuous rotation of the gantry and  
5 simultaneous table motion smooths the irradiated field reducing "gaps" or "hot spots" in the irradiated field.

In addition, helical scanning improves the speed of treatment by eliminating the need to accelerate and decelerate the patient for repositioning between 360°  
10 rotations of the gantry such as might be required if the patient were treated along a series of distinct slices perpendicular to the axis of rotation and separated along the axis of translation.

In another embodiment, the gantry may support not  
15 only a radiation source for radiation therapy, but also a low energy x-ray source and an opposed detector array for acquiring data for computerized tomographic reconstructions as the gantry rotates.

It is yet another object of the invention to  
20 decrease the time and improve the accuracy of both therapy planning and therapy sessions so that both planning and therapy may be conducted in short succession. By reducing the freedom of movement of the radiotherapy system to a single plane there is improved  
25 correlation between the data generated by the tomographic imaging system and the data necessary to control the radiation therapy system. The similar geometries of the two systems permit their effective combination.

The tomographic images developed by the CT machine  
30 may provide the necessary data to produce signals to control the compensator. In one embodiment, the therapist identifies the tumor directly with reference to the tomographic image.

By having the tomographic imaging system and  
35 radiation therapy system on a common gantry, a new tomographic image can be produced each time a patient is to receive treatment. The radiologist can view and use



the image to adjust therapy protocol while a patient remains on the translation table.

Yet another object of the invention is to provide a method of tracking the position of the tumor during  
5 therapy and stopping a therapy session if the tumor is in an unanticipated position. The CT machine provides images of the patient that can be related to the image generated during treatment planning. If the patient moves, the mechanism can automatically turn off the  
10 radiation source or alert a therapist of the movement.

The present invention also includes a collimator that operates with a fan beam attenuating compensator to vary the thickness and orientation of a fan beam during radiation therapy. By changing the thickness of the fan  
15 beam the irradiation of healthy tissue in slices at the ends of the tumor may be reduced and/or multiple slices may be reduced and/or multiple slices may be treated at the same time.

Specifically, the collimator of the present  
20 invention operates in conjunction with an attenuator disposed between the radiation source and the patient. The attenuator can independently control the intensity of the rays of the fan beam. The collimator includes a first and a second radiopaque jaw disposed within the fan  
25 beam for moving together and apart along an arcuate path. When not occluded by the jaws, the radiation source illuminates a radiation window on the patient. When the jaws are together they occlude the fan beam and when apart they define a collimated beam, the first jaw  
30 defining a first collimated edge and the second jaw defining a second collimated edge of the beam. A translator moves a treatment volume along a translation axis with respect to the beam plane wherein relative motion between the treatment volume and the beam plane  
35 causes the treatment volume to first pass through the first collimated beam edge and second pass through the second collimated beam edge. A motivation mechanism

moves the opposing edges of the first and second jaws together and apart within the fan beam to control the thickness of the collimated beam passing therebetween as a function of the relative position of the radiation window with respect to the treatment volume. Furthermore, motion of the jaws is general in that each jaw can cross the beam centerline.

Thus, another object of the invention to provide a radiation therapy apparatus that can adjust the thickness of a fan beam so as to subtend arbitrarily sized portions of a tumor depending on the portion of the tumor being irradiated. This provides two benefits. First, at the ends of the tumor, where the fan beam does not completely cross a slice being treated, the fan beam can be made thinner so as to reduce the radiation exposure of healthy tissue. The ability to treat slices arises from use of the attenuator which permits control of individual rays of the fan beam. Second, when adjacent slices require similar treatment, the fan beam may be made wider, and those slices may be treated simultaneously to reduce the total treatment time.

Another object of the invention to provide a radiation therapy machine capable of determining which adjacent portions of a tumor can be treated simultaneously with radiation.

A comparison module receives sinograms for each individual slice of a treatment volume. Each sinogram includes intensity data for every ray of the fan beam for every angle about that slice. The comparison module compares the sinograms of adjacent slices of the tumor and produces a difference value. If two compared sinograms are similar, the two adjacent slices are treated as one.

Another object of the invention is to provide a radiation therapy machine that is capable of orienting the fan beam relative to the plane of gantry rotation. By constructing the collimator so that the separate jaws

may cross the centerline of the fan beam, the direction of the fan beam may be oriented at an angle relative to the plane of gantry rotation. This orientation enables targeting of a tumor site from all three dimensions and thus provides more therapy choices.

The foregoing and other objects and advantages of the invention will appear from the following description. In the description, reference is made to the accompanying drawings which form a part hereof and in which there is shown by way of illustration several preferred embodiments of the invention. Such embodiments do not necessarily represent the full scope of the invention, however, and reference must be made therefore to the claims herein for interpreting the scope of the invention.

#### Brief Description Of The Drawings

Fig. 1 is a view in partial section of the radiation therapy machine of the present invention;

Fig. 2 is a cross sectional view of the therapy machine of Fig. 1 taken along line 2-2 of Fig. 1 showing the lateral orientation of the treatment and imaging sources;

Fig. 2(a) is a cross sectional view of the therapy machine of Fig. 1 taken along line 2A-2A of Fig. 2 showing the radial orientation of the treatment and imaging sources as well as the detector array;

Fig. 3 is a perspective view of the compensator assembly used in the present invention, showing the compensator leaves and their associated motive sources (e.g. pneumatic cylinders);

Fig. 4 is a cross-section of the compensator assembly of Fig. 3 along line 4-4 showing the trapezoidal aspect of each compensator leaf, for a fan beam of radiation, and the guide rails for supporting the compensator leaves when they move;

Fig. 5 is a cutaway perspective view of a set of

guide rails and one leaf of Fig. 4 showing a collar for supporting the leaf in its fully closed position;

Fig. 6 is an elevational view of the collimator jaw assembly of the present invention disposed between a radiation source, compensator assembly and a patient with a tumor;

Fig. 7 is a cross sectional view of the jaws of the collimator assembly of Fig. 6 along line 7-7 showing a screw and nut used to translate the jaws along a way;

Fig. 8 is a block diagram showing the elements of a radiation therapy apparatus incorporating a conventional CT scanner and the compensator of the present invention and including a computer suitable for controlling that compensator per the present invention;

Figs. 9(a)-(d) are dose distributions of a hypothetical tumorous region showing dose intensity by lines of equal dose, with Fig. 9(a) showing a desired dose distribution and Figs. 9(b), (c), and (d) showing progressive actual dose distributions after two, three and ten iterations per present invention;

Fig. 10 is a diagrammatic representation of a patient receiving radiation therapy, showing the scatter kernel and the coordinate system used to describe the present invention;

Fig. 11 is a perspective representation of a monodirectional scatter kernel associated with a radiation beam at one gantry angle;

Fig. 12 is a perspective representation of a composite multidirectional scatter kernel associated with a plurality of radiation beams at multiple gantry angles;

Fig. 13 is a block diagram depicting the fluence profile calculator which takes a desired dose map and calculates a fluence profile;

Fig. 14 is a block diagram depicting the overall iterative method of controlling the compensator of the present invention, employing the fluence profile calculation method of Fig. 13;

Figs. 15(a)-(c) are perspective views of plots showing the error between the desired dose distribution and the actual dose distribution obtained with the present invention for one, two and four steps of iteration respectively.

Fig. 16(a)-(c) are a perspective view of a simplified tumor and graphs showing gaps or hot spots that may result from two junctioned radiotherapy beams;

Fig. 17(a) is a perspective view of the simplified tumor of Fig. 16(a) and Figs 17(b)-(e) are graphs showing the radiation beam position relative to the tumor in Fig. 17(a) from various gantry angles during a helical therapy session;

Fig. 18(a)-(e) are a perspective view of the simplified tumor of Fig. 16(a) and graphs showing the cumulative radiation dose delivered to the tumor in Fig. 18(a) at different times during a helical therapy session, each graph in Figs. 18(b)-(e) corresponding to an adjacent graph in Figs. 17(b)-(e);

Fig. 19 is a block diagram depicting the motivating mechanism operation of the present invention;

Fig. 20 is a perspective view of a simplified tumor having a thin portion and a thick portion;

Figs. 21(a)-(c) are graphs showing sample slice sinograms for correspondingly numbered planes of the tumor of Fig. 20. Each sinogram is three dimensional and contains beam width intensity data for each attenuating leaf of the compensator at each gantry angle for a single slice of the tumor;

Fig. 22 is a block diagram depicting the method of the present invention for creating an irradiation zone map out of similar sinograms;

Figs. 23(a)-(c) are perspective views showing the changing spatial relationship between the collimator jaws of a helical scanning therapy system in which the jaws maintain a fixed separation as a tumor is translated relative to the jaws;

Figs. 23(d)-(f) are side views corresponding to the perspective views of Figs. 23(a)-(c); and

Figs. 24(a)-(c) are perspective views showing the motion of the collimator jaws of the present invention as a tumor is translated relative to the jaws;

Figs. 24(d)-(f) are side views corresponding to the perspective views of Figs. 24(a)-(c).

#### Description Of The Preferred Embodiment

Referring to Fig. 1, a radiation therapy machine 10 embodying the present invention includes, a stationary, generally block shaped radiation barrier 12 constructed of a dense concrete or other suitable radiation attenuating material. A cylindrical bore 13 centered on horizontal bore axis 15 passes through the front and rear surfaces 24 and 25 of the barrier 12.

A table 11 disposed along a translation axis 17 may slide along that axis 17 through the bore 13 passing first the front surface and then the rear surface 25. The table 11 is supported along guide tracks 6 and moved by a motorized drive, such as is well known in the art, so that its position may be controlled by a computer as will be described.

Referring also to Fig. 2, the bore 13 includes internal recesses 16, 19 and 16', each generally cylindrical and co-axial with the bore axis 15. Recess 16 is disposed near the front surface 24 of the protective barrier 12 and receives the radially outer edge of an annular ball bearing 27 as will be described below. Recess 16' is similar to recess 16 but displaced along the axis of the bore 13 near the back surface 25 of the protective barrier 12. Recess 16' holds the radial outer edge of annular ball bearing 27'.

Centered between recesses 16 and 16' is recess 19 having a radius greater than recess 16 or 16' so as to form a volume for the support of various equipment, to be described, outside of the volume of the bore 13.

Referring to Figs. 2 and 2a, an annular gantry 14, radially symmetric about the bore axis 15, fits within the recesses 16, 16' and 19 and has outer surfaces conforming generally to the recesses 16, 16' and 19'.

5 The gantry 14 is supported at two ends by the radially inner edges of bearings 27 and 27' for rotation on those bearings within the barrier 12. The gantry 14 is generally concave inwardly, having a U-shaped portion 20 held with recess 19' with radially inwardly extending  
10 walls 21. Attached to the radially extending wall 21 nearest to the back edge 25 is a radiation therapy source 32 producing a fan beam of high energy radiation 26 directed toward and perpendicular to bore axis 15. The fan beam 26 lies generally within a plane 22  
15 perpendicular to the bore axis 15 and at all times is directed toward the barrier 12.

Diametrically opposed to the therapy source 32 on the opposite side of the gantry 14 is a primary barrier 107. The primary barrier 107 subtends and occludes each  
20 ray 47 exiting the patient and hence minimizes scatter within a therapy area. For verification purposes, a megavoltage detector array 105 may be placed on the internal surface of the primary barrier 107.

An x-ray source 28 and an imaging detector array 30  
25 are securely disposed along the vertically extending walls 21 closest to the front end 24 of the barrier 12 so as to direct a beam of x-rays 29 along a plane parallel to, but spaced from plane 22 and along an axis at substantially right angles to that of the fan beam 26.  
30 This spacing of the plane of the x-rays 29 and fan beam plane 22 ensures sufficient space within the barrier 12 to house the therapy source 32 and x-ray source 28 and prevents unwanted signal interference between the two systems.

35 The radiation source 32, primary barrier 107, the x-ray source 28 and x-ray detector 30 are all removed from the volume of the bore 13 so as not to interfere with a

patient within the bore 13 upon rotation of the gantry 20.

The gantry 20 may be rotated by a shaft 7 extending through the barrier 12 and driven by conventional means. Attached to the shaft is an encoder (not shown) for providing signals indicating the exact angle of the gantry 20 within the barrier 12.

Referring now to Fig. 3, a radiation therapy source 32 produces a generally conical radiation beam 34' emanating from a focal spot 35 and directed towards a patient (not shown). The conical beam 34 is collimated by a radiation opaque collimator 36 constructed of a set of rectangular collimator blades 31 to form a generally planer fan beam 26 centered about a fan beam plane 38, the fan beam having a width 39 measured along the fan beam plane and a thickness 37 perpendicular thereto. The fan beam 26, if unoccluded, defines a radiation window 33 directed toward the patient.

#### I. The Compensator

A compensator 40 is centered in the fan beam 26 above the collimator 36 and about the fan beam plane 38, prior to the radiation being received by the patient, and includes a plurality of adjacent trapezoidal leaves 41 which together form an arc of constant radius about the focal spot 35. The leaves 41 are held in sleeves 43. The sleeves 43 are constructed of relatively radio translucent materials and attached at their inner ends 44 to a mounting plate 45 which is fixed relative to the focal spot 35. The mounting plate 45 is constructed of a sturdy, radiopaque material and is positioned just outside the fan beam 26 to prevent interference with the fan beam 26.

Preferably, the leaves 41 of the compensator 40 subtend the entire fan beam 26 to divide the fan beam 26 into a set of adjacent slab-like rays 47 at offset angles  $\phi$ . Referring also to Fig. 4, each sleeve 43 is open at



its outer end 48 to receive, by sliding, a comparably sized trapezoidal leaf 41 constructed of a dense, radiopaque material such as lead, tungsten, cerium, tantalum or a related alloys.

5 Each leaf 41 may slide completely within its corresponding sleeve 43 to block the ray 47 associated with that sleeve 43. When the leaf 41 blocks its corresponding ray 47, it is referred to as being in a "closed state". The sleeves 43 are of ample length to  
10 permit each leaf 41 to slide out of the path of the fan beam 26, so as to leave its corresponding ray 47 completely unobstructed, and yet to still be guided by the sleeve 43. In this non-blocking position, a leaf is referred to as being in the "open state".

15 Each leaf 41 may be moved rapidly between its open and closed states by means of a corresponding pneumatic cylinder 51 connected to the leaf 41 by a flexible link 50. The pneumatic cylinders 51 have internal pistons (not shown) that may be moved at high velocity between  
20 the ends of the cylinders 51 by means of pressurized air coupled to the cylinders 51 through supply hoses 52. The supply hoses 52 are fed by a compensator control to be described below. The pneumatic cylinders 51 are capable of applying high forces to the leaves 41 to move them  
25 rapidly and independently between the open and closed states.

Referring now to Figs. 4 and 5, the leaves 41 are supported and guided within the sleeves 43 by guide rails 54 fitted into notches 55 cut along the edges of the  
30 leaves 41. The notches 55 allow the guide rails 54 to slidably retain the leaves 41 within the sleeves 43 during motion between the open and closed states.

In the closed state, the inner end 44 of each leaf 41 is captured by a rigid collar 58 attached to the  
35 mounting plate 45, which aligns the leaf 41, more accurately than may be done by the guide rails 54, with the mounting plate 45 and hence with the fan beam 26.

Whereas the guide rails 54, which are ideally radio translucent, are relatively insubstantial, in contrast, the collar 58, positioned outside the fan beam 26 on the mounting plate 45, need not be radio-translucent and hence is more substantial in construction. A collar (not shown) similar to collar 58, supports each leaf 41 when it is fully in the open state. Because the leaves 41 spend most of their time fully in the open or closed states, they are, at most times, firmly located by a supporting collar.

## II. The Collimator

Referring to Fig. 6, a collimator 36 is positioned between the compensator 40 and the patient 17 directly within the fan beam 26, and includes two jaws 31, a jaw way 250 (seen best in Fig. 7) and two servo motors 253.

Each jaw 31 is a rectangular prism and, like the attenuating leaves 41, is constructed of a dense, radiopaque material such as lead, tungsten, cerium, tantalum or a related alloy. The jaws 31 have opposing planar faces 249 that are substantially parallel to adjacent fan beam rays 47. Each jaw also has a back face 243 opposite its planar face 49. The jaws 31 of the collimator 36 should be sized so that, when their planar faces 249 abut within the fan beam 26 the jaws 31 subtend the entire beam width 39 and thickness 37 (see Fig. 3).

Each jaw 31 is provided with two pivotally mounted linear bearings 244 attached on either of its outer sides. A bored hole through its back face 243 defines a screw chamber 251. On the interior wall of each screw chamber 251 there is a hollowed out channel 252 concentric therewith that securely receives a nut 239.

Referring also to Fig. 7, the jaws 31 are supported by two arc shaped support rods 245 received by the pivotally mounted linear bearings 244. The arc shaped support rods 45 together form an arc shaped way 250 of constant radius about the focal spot 35. The way 250 is

open at both of its outer ends 242 adjacent to the back faces 243 of the jaws 31 and is long enough to receive both jaws 31 of the collimator 36. As seen in Fig. 6, the support tracks 245 of way 250 are attached at their outer ends 247 to mounting members 246. The mounting members 246 are fixed relative to the focal spot 35. The support tracks 245 and the mounting members 246 are constructed of radiopaque material and are positioned outside the fan beam 26 to prevent interference with the fan beam 26. The jaws 31 may move apart along the way 250 enough to define a gap 221 equal to the thickness 37 of the fan beam 26.

Each jaw 31 may be moved with respect to the focal spot 35 and the other jaw 31 by means of a servo motor 253 connected by a flexible link 241 to jaw screw 237. The flexible link 241 allows the servo motor 253 to remain stationary while its associated jaw 31 is driven along the arcuate way 250. The jaw screw 237 is threadably received in the nut 239 of each jaw 31. The servo motors 253 are held stationary relative to the gantry 20 and are controlled by a collimator control module 72 in a manner to be described below.

### III. Radiation Therapy Control Circuitry

Referring now to Fig. 8, the radiation therapy source 32 is controlled by a radiation control module 60 which turns the radiation beam 26 on or off under the control of a computer 61.

A compensator control module 62 provides a source of compressed air and valves to gate that air through supply hoses 52 to control, separately, the pneumatic cylinders 51 to move each of the leaves 41 in and out of its corresponding sleeve 43 and ray 47 (see also Fig. 3). The compensator control module 62 also connects with the computer 61 to allow program control of the compensator 40 to be described.

A collimator control module 64 controls the spatial

relationship between the collimator jaws 31 to effect a single steady state collimated beam 26. The collimator module 64 is also connected to the computer 61 to allow program control of the collimator jaws 31 to be  
5 described.

A tomographic imaging system 63 employing the x-ray source 28 and the opposed detector array 30 are advantageously mounted on the same gantry 14 as the radiation source 32 to produce a tomographic or slice  
10 image of the irradiated slice of the patient 59 prior to radiation therapy for planning purposes. Control modules for the tomographic imaging system 63 include: x-ray control module 67 for turning on and off the x-ray source 28, and data acquisition system 68 for receiving data  
15 from the detector array 30 in order to construct a tomographic image. An image reconstructor 69 typically comprising a high speed array processor or the like receives the data from the data acquisition system 68 in order to assist in "reconstructing" a tomographic image  
20 from such data according to methods well known in the art. The image reconstructor 69 also communicates with computer 61 to assist in high speed computations used in the present invention as will be described below. The tomographic image allows verification of the patient  
25 setup just prior to radiation therapy treatment. It should also be understood to one of ordinary skill in the art that a high energy detector array may also be placed to receive radiation from the radiation source 32 through the patient 59 to assist in verification of the  
30 treatment.

A gantry control module 66 provides the signals necessary to rotate the gantry 14 and hence to change the position of the radiation source 32 and the angle  $\theta$  of the fan beam 26 for the radiation therapy, as well as to  
35 change the position of the computed tomography x-ray source 28, the x-ray detector array 30 and the primary barrier 107. Gantry control module 66 connects with

computer 61 so that the gantry may be rotated under computer control and also to provide the computer 61 with a signal indicating the gantry angle  $\theta$  to assist in that control.

5           A terminal 70 comprising a keyboard and display unit 71 allows an operator to input programs and data to the computer 61 and to control the radiation therapy and tomographic imaging equipment 63 and to display tomographic images produced by the image reconstructor 69  
10 on the display 71. A mass storage system 73, being either a magnetic disk unit or drive for magnetic tape or optical media, allows the storage of data collected by the tomographic imaging system 63 for later use.

          Computer programs and sinograms (to be described)  
15 for operating the radiation therapy system 10 will generally be stored in mass storage unit 73 and loaded into the internal memory of the computer 61 for rapid processing during use of the system 10.

#### IV. Operation of the Therapy System

20           Referring again to Figs. 1 and 6, as part of a therapy planning session, a patient is placed on the translation table 11 so that the exact location of the tumor within the patient relative to the table 11 is known. The table 11 is translated through the gantry 14.  
25 During translation the x-ray imaging source 28 is rotated about the patient while directing an x-ray beam 29 toward the detector array 30 so that the beam 29 sweeps a helical pattern through a tumor 72. A position indicator (not shown) communicating through table control module  
30 200 with computer 61 tracks the movement of the table 11 to provide the computer 61 with the precise position of the tumor 72 relative to the fan beam plane 38. Through detecting methods well known in the art, the x-ray source 28 and detector array 30 cooperate to produce x-ray data  
35 from a plurality of gantry angles  $\theta$  and table positions. The computer 61 stores the raw x-ray data. This data is

used by the reconstructor 69 to produce tomographic images of each slice of the patient that are in turn used to generate treatment sinograms for therapy sessions.

Each sinogram contains a plurality of fluence profiles that will control the compensator and collimator during a later therapy session. The fluence profiles describe the intensity or fluence of each ray 47 of the radiation beam 26 from the radiation source 32 that is desired for that gantry angle  $\theta$  at a given position of the patient translation table (not shown) as translated through the radiation beam 26. Together, the fluence profiles for each gantry angle make up a treatment sinogram for a particular position of the translation table 11.

During operation of the radiation therapy unit 10, the compensator control module 62 receives from the computer 61 a fluence profile for each gantry angle. The compensator control module 62 moves the leaves 41 of the compensator 40 rapidly between their open and closed states to either fully attenuate or provides no attenuation to each ray 47. Gradations in the fluence of each ray 47, as needed for each fluence profile, are obtained by adjusting the relative duration during which each leaf 41 is in the closed position compared to the relative duration during which each leaf 41 is in the open position, for each gantry angle. The ratio between the closed and open states or the "duty cycle" for each leaf 41 affects the total energy passed by a given leaf 41 at each gantry angle and thus can generate arbitrarily shaped beam fluence profiles. The ability to control the beam fluence profile at each gantry angle permits accurate control of the dose provided by the radiation beam 26 through the irradiated volume of the patient 59 by therapy planning methods to be described below.

During rotation of the gantry 14 and translation of the patient 59, the collimator control module 64 sends signals to the servo motors 253 moving the jaws 31 to

change the width 39 of the fan beam 26 as described below.

The fluence profiles of the treatment sinogram are determined by therapy planning software (described below) and stored in the computer 61.

#### V. Therapy Planning Software

The generation of a treatment sinogram needed to obtain the full benefits of the above described compensator 40 and collimator 36 is performed by specially developed software running on the computer 61 and reconstructor 69. Although the treatment planning is performed in software, it will be recognized that the planning may also be implemented in discrete electronic circuitry dedicated to this operation and that such dedicated circuitry may be employed to provide even greater speed to this process.

Referring to Fig. 9(a), after tomographic images corresponding to various slices of the tumor are generated by the reconstructor 69, the generation of the desired treatment sinogram to control compensator 40 begins with the definition of a desired dose map 75. The desired dose map 75 may be most easily entered by displaying the tomographic image of each slice of a patient on the display 71 of the terminal 70 and manually tracing around the tumorous area 76 using a track-ball or similar input device as is well understood in the art. Standard area-filling computer programs may be used to transfer the dose values assigned to each traced region to the appropriate element in the array of memory representing the desired dose map 75.

A typical desired dose map 75 assigns a relatively high radiation dose, within a dose constraint, to an area of tumorous tissue 76 and a second lower radiation dose to the area of healthy tissue 77 outside of that region. The healthy tissue 77 may include an area 78 including a radiation sensitive organ or the like to which an even

lower radiation dose may be assigned. The desired dose map 75 is stored within the memory of computer 61 as an array of elements each element holding one digital value.

Each element of the dose map 75 thus defines the  
 5 dose desired at each of the plurality of volume elements 80 ("voxels") within a slice of the patient 59. Referring to Fig. 10, each voxel 80 of the patient 59 may be identified by a vector  $\vec{r}$  defined from a given reference point 81. The dose at each voxel 80 is  $D(\vec{r})$ .

## 10 A. Converting Dose to Terma

### 1. Terma

Generally, the dose at any voxel  $\vec{r}$  will depend on the energy received at that voxel  $\vec{r}$  from radiation scattered from adjacent voxels  $\vec{r}'$  (where adjacent voxels  $\vec{r}'$   
 15 include the voxel  $\vec{r}$ , i.e., the radiation received directly from the radiation source 32). The dose  $D(\vec{r})$  for a given voxel  $\vec{r}$  is given by the following formula:

$$D(\vec{r}) = \int T(\vec{r}') A(\vec{r}-\vec{r}') d^3\vec{r}' \quad (1)$$

where  $T(\vec{r}')$  is a value indicating the magnitude of  
 20 the primary total energy released from  $\vec{r}'$  per unit mass of that voxel  $\vec{r}'$  and is called the "terma" (total energy released per unit mass).

For a monoenergetic external radiation source, the terma rate  $T(\vec{r})$  is described by:

$$25 \quad \dot{T}(\vec{r}') = \frac{\mu}{\rho}(\vec{r}') E \int \phi(\vec{r}') dt \quad (2)$$

where  $\frac{\mu}{\rho}$  is an effective mass attenuation value at  
 the voxel  $\vec{r}$ ,  $E$  is the energy of the radiation photons in Joules,  $\phi$  is the distribution of the fluence rate (flux density). The integration of energy times fluence rate  
 30 over time is energy fluence  $\Psi(\vec{r}')$  where:

$$\Psi(\vec{r}') = E \int \dot{\phi}(\vec{r}') dt \quad (3)$$



hence

$$T(\vec{r}') = \frac{\mu}{\rho}(\vec{r}')\psi(\vec{r}') \quad (4)$$

Equation (4) basically relates how much energy from the ray 47 interacts with the voxel  $r'$ .

## 5            2.    Convolution Kernel

$A(\vec{r}-\vec{r}')$  is a convolution kernel describing non-stochastic energy transport or scattering in a uniform medium.  $A(\vec{r}-\vec{r}')$  thus describes how the energy from each voxel  $\vec{r}'$  spreads to contribute to the dose at voxel  $\vec{r}$ .

10            The kernel  $A(\vec{r}-\vec{r}')$  may be generated using a Monte Carlo method as is generally understood in the art. As mentioned, it is a three-dimensional function indicating the fraction of energy absorbed at voxel  $\vec{r}$  per unit of energy released at voxel  $\vec{r}'$ . The energy emitted from the  
 15            terms of each voxel  $\vec{r}'$  finds its source in a directed ray 47 from external radiation source 32 and thus  $A(\vec{r}-\vec{r}')$  is generally anisotropic as suggested in Fig. 11, spreading outward away from the entry of ray 47. Energy conservation requires that:

$$20 \quad \int A(\vec{r}') d^3\vec{r}' = 1.0 \quad (5)$$

That is, if the energy transferred by the primary interaction were all deposited on the interaction point, the kernel would be approximated as a delta function.

Referring still to Fig. 11, the anisotropy of  
 25             $A(\vec{r}-\vec{r}')$  is related to the gantry angle  $\theta$  and thus of the angle of incidence of the ray 47 at  $\vec{r}'$ . If the gantry angles  $\theta$  at which the patient 59 is irradiated are predetermined, a multidirection convolution kernel  $B(\vec{r}-\vec{r}')$  shown in Fig. 12, may be created from weighted  
 30            superimposition of the kernels  $A(\vec{r}-\vec{r}')$ .

Referring to Fig. 12, assuming that the spreading of

radiation is approximately equal for all beam directions and the rays 47 from each gantry angle  $\theta$  contribute equally to the terma at voxel  $\vec{r}'$ , then the multidirectional convolution kernel reduces to a  
 5 "isotropic" form as follows:

$$B(\vec{r}-\vec{r}') = \frac{1}{n} \sum_{i=1}^n A(\vec{r}-\vec{r}')_i \quad (6)$$

where  $n$  is the number of discrete gantry angles from which rays 47 are projected.

For multiple rays 47 at different gantry angles, the  
 10 total dose at a given voxel  $\vec{r}$  is the sum of doses from each constituent beam is therefore:

$$D(\vec{r}) = \int T(\vec{r}') B(\vec{r}-\vec{r}') d^3\vec{r}' \quad (7)$$

where  $T(\vec{r}') = nT(\vec{r}')_i$ , the latter term being the contributed portion of the terma for the  $i$ th gantry  
 15 angle.

This simplification assumes that the contribution to the terma from each ray 47 is equivalent and takes advantage of the distributive property of convolution. Errors in this assumption are reduced by the filtration  
 20 to be discussed later.

Equation (7) substantially simplifies the calculation of dose from terma but still requires a convolution for each voxel  $\vec{r}$  times the total number of voxels  $\vec{r}'$  to calculate the dose over the entire patient  
 25 volume. Preferably, therefore, the calculational efficiency of the fast Fourier transform can be used and equation (7) converted to the following:

$$D(\vec{r}) = F^{-1}\{F\{T(\vec{r}') \cdot F\{B(\vec{r}-\vec{r}')\}\}\} \quad (8)$$

where  $F$  and  $F^{-1}$  symbolize Fourier and inverse Fourier  
 30 transforms respectively. This simplification of equation (8) requires that the kernel  $B(\vec{r}-\vec{r}')$  be spatially invariant and relies on the convolution theorem which

states that convolution of two spatially invariant quantities in a space domain is equivalent to multiplication in the frequency domain.

The assumption of the spatial invariance of  $B(\vec{r}-\vec{r}')$  is correct only to a first order approximation.

Typically, the kernel  $B(\vec{r}-\vec{r}')$  for an external radiation source 32 is a complex function of: (1) beam hardening of a polyenergetic x-ray beam (i.e., the effect of the filtration of the patient 59 in increasing the proportion of high frequency or high energy radiation components), (2) the number of rays 47 crossing each voxel, and (3) exponential attenuation by the patient mass.

In the preferred embodiment, this first factor, beam hardening, is neglected because it is an effect smaller than the attenuation problem. Thus, the photon energy spectrum in the patient 59 may be assumed to be the same as that of the external radiation source 32. This simplification is not required, however, and it will be understood that beam hardening could be accurately accounted for by representing a photon energy spectrum by a finite number of separately convolved energy intervals.

The second factor, the difference in the number and orientation of rays 47 that cross each voxel, caused by the geometry of a finite number of gantry angles and the fan orientation of the beam 26, affect spatial invariance. Problems arising from the fan orientation of the beam (in contrast to a parallel beam geometry) are largely solved if there is a full rotation of the gantry 14. Errors resulting from the fact that irradiation is performed at only a finite number of gantry angles have been determined to be acceptable.

The third factor affecting the assumption of spatial invariance is the attenuation of the medium. This affects the fractional contribution of the total terma from the beams at each gantry angle. Accordingly, in those steps of the planning procedure, as will be noted below, where accurate calculation of dose is critical,

the dose distribution is calculated separately for each beam based on the attenuation of overlying voxels, such attenuation deduced from the parameters of the tomographic image. In this case the simplification of equation (8) may not be employed and repeated convolutions must be performed. In certain steps in the planning process, however, as will be noted, an estimate is sufficient and in these cases  $B(\vec{r}-\vec{r}')$  is assumed to be spatially invariant and the dose calculated according to equation (8).

Production of terma values from a desired dose map 75 is then simply the process of inverting equation (8) as follows:

$$T(\vec{r}') = F^{-1} \left\{ \frac{F\{D(\vec{r})\}}{F\{B(\vec{r}-\vec{r}')\}} \right\} \quad (9)$$

This inversion requires that there be no significant "zeros" (typically at high frequencies) in the denominator term  $F\{B(\vec{r}-\vec{r}')\}$  more simply that the kernel  $B(\vec{r}-\vec{r}')$  be spatially compact (i.e., the Fourier transform of a spatially compact kernel will have significant high frequency content). It has been determined by the present inventors that the kernels dictated for patients 59 are sufficiently compact to allow this Fourier deconvolution.

Referring now to Fig. 13, this deconvolution to produce a terma map 83, giving the terma for each voxel  $\vec{r}$  from the desired dose map 75, is represented by process block 84.

#### B. Converting Terma to Voxel Energy Fluence

Knowing the terma map 83, the energy fluence  $\Psi(\vec{r})$ , which is a measure of the beam intensity, can be determined at each corresponding voxel by equation (4) from a knowledge of  $\mu/\rho$  as follows:

$$\psi(\vec{r}') = \frac{I(\vec{r}')}{\frac{\mu}{\rho}(\vec{r}')} \quad (10)$$

The value of  $\mu/\rho$  may be estimated and considered a constant or actual  $\mu/\rho$  may be deduced from the tomographic scan data collected by means of the tomographic imaging system 63, (shown in Fig. 8). In this manner and as illustrated by process block 85 of Fig. 13, a fluence map 86 giving the fluence at each point of the terma map may be determined.

### 10 C. Converting Voxel Energy Fluence to Energy Fluence Profile

The energy fluence  $\Psi(\vec{r}')$  at each voxel  $\vec{r}'$  is related to the energy of the ray 47 exiting the compensator 40 by the relation:

$$\psi(\vec{r}') = \psi_0(\phi, \theta) e^{-\int \frac{\mu}{\rho}(\vec{r}) \rho(\vec{r}) \delta(\vec{p}-\vec{r}) d\vec{r}} \left( \frac{SSD^2(\phi, \theta)}{|\vec{r}'|^2} \right) \quad (11)$$

15 where  $\Psi_0(\phi, \theta)$  is the energy fluence for a given ray 47 as described by  $\delta(\vec{p}-\vec{r})$  at the exit of the compensator 40 and serves to define the fluence profile of the compensator and  $\theta$  and  $\phi$  are the gantry angle and the offset angles of the ray 47 as previously described.

20 The exponential term represents the attenuation of the ray 47 from the exit of the compensator 40 to the voxel  $\vec{r}$  caused by the mass of the patient 59 where by  $\mu/\rho(\vec{r})$  is the attenuation for each voxel  $\vec{r}$  along the ray 47,  $\rho(\vec{r})$  is the density of each voxel  $\vec{r}$ ,  $SSD(\phi, \theta)$  is the distance between the exit of the compensator 40 and the surface of the patient 59,  $\hat{r}$  is a unit vector along  $\vec{r}$  (where the origin of is now assumed to be the center of rotation of the gantry 14), and  $p$  is the perpendicular distance from the gantry's center of rotation 15 and the ray 47. The vector is simply a vector along the ray 47 to provide an integration variable.

The fluence at each voxel  $\vec{r}$  is related to the fluence of the radiation beam 26 emitted from the compensator 40 by equation (11). In the preferred embodiment, the density and attenuation of each voxel  $\vec{r}$ ,  
 5  $\mu/\rho(\vec{r})$  and  $\rho(\vec{r})$  are assumed to be constant and the fan beam of radiation is approximated by a parallel beam, hence  $\frac{SSD^2(\phi, \theta)}{|\vec{r}|^2} = 1$ . Borrowing from the mathematics of

tomographic image reconstruction, the fluence map 86 may be "reverse" back projected (i.e. projected) by projector  
 10 87 to determine a fluence profile to be produced by the external-source necessary to generate the desired fluence map and hence dose.

This projection is simply the opposite of a typical back projection used to form an image of a tomographic  
 15 slice of a patient 59 from a series of projections taken in a tomographic imaging system. Because a projection is a line integral across a distribution, the energy fluence distribution for each voxel (equation (11)) is first differentiated with respect to the rayline  $\vec{t}$ .

$$20 \quad \frac{d\psi(\vec{r})}{dt} = \left[ \frac{\mu}{\rho}(\vec{r}) \rho(\vec{r}) \delta(p - \hat{p} \cdot \vec{r}) + \frac{2}{t} \right] \psi(\vec{r}) \quad (12)$$

The line integral of  $\frac{d\psi(\vec{r})}{dt}$  along  $\vec{t}$  corrected for attenuation and inverse-square fall off, then represents the projection operation and  $\Psi_0(\phi, \theta)$  the fluence profile over the offset angles  $\phi$  of each gantry angle  $\theta$ , is:

$$25 \quad \Psi_0(\phi, \theta) = \int \left[ \frac{\mu}{\rho}(\vec{r}) \rho(\vec{r}) \delta(p - \hat{p} \cdot \vec{r}) + \frac{2}{t} \right] \psi(\vec{r}) e^{-\int \frac{\mu}{\rho}(\vec{r}) \rho(\vec{r}) \delta(p - \hat{p} \cdot \vec{r}) d\vec{t}} \left( \frac{|\vec{t}|^2}{SSD^2(\phi, \theta)} \right) x(p - \hat{p} \cdot \vec{r}) d\vec{t} \quad (13)$$

The projection of equation (13) is represented by projector 87 in Fig. 13.

The projection process, for the purpose of computing fluence profiles for the compensator 40, differs in a fundamental way from the simple inverse of tomographic back projection. The difference is primarily in a concern for the sharpness in the transition of the dose between the irradiated tumorous tissue 76 and the healthy tissue 77. Sharpness in this transition region reduces the irradiation of healthy tissue 77 and is preferred over actual fidelity of the dose to the desired dose map 75.

For this reason, the fluence map 86 from the fluence calculator 85 is prefiltered as shown by process block 88 to produce a filtered fluence map  $\Psi'(\phi, \theta)$  as follows:

$$\Psi'(\phi, \theta) = F^{-1}\{F\{\Psi(\phi, \theta) |\omega|\}\}, \quad (14)$$

where  $\Psi(\phi, \theta)$  is the fluence map 86 and  $|\omega|$  is a ramp filter in frequency space and the '+' subscript indicates the positive component of the filtering result. This prefilter 88 serves to increase the high frequency content of the fluence map 86 and thus to aid in rapid transition of dose at the tumor/non-tumor interface.

It is noted that this prefilter 88 is similar to the filter used in tomographic imaging's "filtered" back projection. That is, like tomographic imaging, the filter de-emphasizes the low frequency components of the projection in producing image data. In addition other prefilters may be applied to correct for the use of the radially symmetric kernel (equation (6)) in computing the dose map from the terma map composed from the fluence profile

In practice the computation of a terma map, the generation of a fluence map and the calculation of the fluence profiles need not be performed as discrete steps but may be accomplished by a direct projection of the dose map with appropriate filtering. The filtering is accomplished by a "fast inversion filter" which combines in projection space the operation of deconvolution and

ramp filtration.

This may be symbolically specified by the following equation

$$\psi(\phi, \theta) = \rho\{D(\vec{r}) \otimes I(t)\} \quad (15)$$

5        where  $\rho$  refers to a projection operation and  $I(t)$  is the fast inversion filter. The  $\otimes$  operators refers to a convolution operation such as would normally be done in Fourier space using a fast Fourier transformation.

10        Referring still to Fig. 13, the fluence profile calculations of block 90, including the deconvolver 84, the fluence calculator 85, the prefilter 88 which includes any projection space filter (such as a ramp filter, a fast inversion filter followed by truncation of zeros), and the projector 87 thus produce fluence  
15 profiles which together create an estimated treatment sinogram 91' from the desired dose map 75. The fluence profile calculator 90 may use the Fourier convolution of equation (9) in the estimate of the fluence profiles at this stage, accepting minor inaccuracies in that process,  
20 to be corrected at a later stage, as will be described below.

#### D. Iteration

Referring now to Fig. 14, the fluence profile calculator 90 converts the desired dose map 75 to an  
25 estimated treatment sinogram 90', however the fluence profiles of this estimated treatment sinogram 90' may not be used to control the compensator 40 because, in general, the estimated treatment sinogram 90' will include positive and negative values of fluence. Only  
30 positive values of fluence are physically realizable by the compensator 40; a negative value of fluence would represent a ray 47 that absorbed radiation along its path which is physically unrealizable.

Accordingly, at process block 82, the fluence values  
35 of the estimated treatment sinogram 90' are truncated to positive fluence values 89. As a result of this



truncation, the estimated treatment sinogram 90' no longer produces the desired dose map.

The amount of error resulting from the truncation producing the positive fluence profiles 89 is determined by back projecting the positive fluence values 89 to an actual dose map 93 deviating from the desired dose map 75. This back projection is accomplished by computing a fluence map from the positive fluence values 89 per equation (11) and a terma map per equation (4) and then convolving the terma map with the kernel per equation (7) to establish the actual dose map 93 per process block 94 of Fig. 14.

In this back projection, the assumption of spatial invariance of the convolution kernel  $B(\vec{r}-\vec{r}')$  is not made so as to produce a more accurate actual dose map 93.

The projection of a fluence profile onto a patient 59 to compute a dose map may be performed by a number of other procedures known to those of ordinary skill in the art.

The actual dose map 93 is compared to the desired dose map 75 to produce residual dose map 96 as indicated by process block 95. In the preferred embodiment, the comparison subtracts from the values of each voxel  $\vec{r}$  of the actual dose map 93, the greater of: a) the corresponding value of desired dose map 75, or b) a predetermined upper dose constraint. The predetermined upper dose constraint is a threshold number that is deemed an acceptable dose to tumorous tissue 76. Clearly, other methods of quantifying the difference between the desired dose map and the actual dose map will be apparent from this description to those of ordinary skill in the art.

The result of this comparison process 95 is to produce a residual dose map 96 shown in Fig 15(a). This residual dose map 96 is then, again, operated on by the fluence profile calculator 90 (in lieu of the desired dose map 75) to produce an error fluence profile 98 (in

lieu of the estimated treatment sinogram 91).

A thus produced error fluence profile 98 is subtracted by subtractor 100 from the estimated treatment sinogram 90' to produce a new estimated treatment  
5 sinogram 90.

As shown in Fig. 14, this new estimated treatment sinogram 90 is repeatedly operated on by process blocks 82, 94, 95 and 96 for a predetermined number of iterations, the magnitude of the error fluence profile 98  
10 values decreasing with each iteration as shown in Figs. 15(b)-(c) until a suitably low error fluence profile 98 is obtained.

The new estimated fluence profile 90 is then truncated per process block 82 to produce a final  
15 sinogram 101 for use in controlling the compensator 40 as previously described.

Referring again to Figs. 9(b), (c) and (d), dose maps obtained by the present invention corresponding to a desired dose map 75 of Fig. 9(a) are shown after: one  
20 iteration (Fig. 9(b)); two iterations (Fig. 9(c)); and ten iterations (Fig. 9(d)). The variations in dose in the target volume shown in Fig. 9(d) are plus or minus 2% about the predetermined upper limit of 1,000 cGy.

#### VI. Helical Scanning

25 Referring to Fig. 16(a), a tumor 132 may be arbitrarily divided into similarly thick tumor slices 133-135. The radiation therapy machine of the present invention, in which the angles of the radiation beams are constrained to a single gantry plane 14, may irradiate  
30 adjacent slices of the tumor 132 separately along the translation axis 17 by rotating 360 degrees and then stopping the irradiation and advancing the patient and table by one slice thickness. The next slice can then be treated with 360 degrees of gantry rotation. This type  
35 of therapy will be termed "stop and shoot" rotation therapy and allows simple relating of the data generated

by the tomographic imaging system 63 and the data used by the radiation therapy machine 10.

It is difficult to use stop and shoot therapy to achieve uniform radiation doses throughout a tumorous  
5 volume without "gaps" or "hot" spot. The reason for this is the fact that the fan beam itself is not uniform in cross section. Also, it is difficult to accurately direct the radiation beam along the edges of the adjacent slices.

10 Refer also to Figs. 16(b)-(c) fluence profiles 143, 151 of the radiation source 32 are non-uniform, dropping off near the edges 144 of the area exposed by fan beam 26. This is true even in machines employing beam flattening filters.

15 Because of fluence drop off, the fluence distribution along the length of the tumor 132 is not completely uniform when stop and shoot rotation therapy is employed.

Referring to Figs. 1, 16(a) and 16(b), if the  
20 patient is advanced by exactly one slice width after each 360 degrees of gantry rotation, gaps will be generated. In this situation, a tumor 132 may be translated partially through the gantry 14 until the fan beam 26 subtends only the first slice 133 of the tumor 132.

25 Starting with the gantry 14 at an arbitrary 0° position, the radiation source 32 is energized to produce and direct the fan beam 26 toward the rotation axis 15 while the radiation source 32 is rotated through an entire 360° rotation. After irradiation of the first slice 133, the  
30 patient is again translated through the gantry 14 into a second position where the fan beam 26 subtends only the second slice 134. After a second 360° rotation of the radiation source 32 the patient is translated into a third position. This stop and shoot protocol continues  
35 until all the slices of the tumor 132 have been irradiated.

Although the slices irradiated by the fan beam abut,

as shown in Fig. 16(b), this procedure results in radiation gaps 148 along the length of the tumor 132 where the edges 144 of the fluence profiles 143 drop off. Clearly, gaps 148 in radiation dose limit radiation effectiveness and should be avoided if possible.

Referring to Figs. 16(a) and 16(c), if the patient is translated by less than the slice thickness after each 360° of gantry rotation, radiation gaps 148 can be eliminated, however, radiation hot spots 154 may result. In this case the thickness of the fan beam 26 used to irradiate a tumor 132 is adjusted so that the main portion 150 of each fluence profile 151 subtends an entire tumor slice while the edges 152 of the profile 151 are on either side of the tumor slice. This thick fan beam technique generates radiation "hot spots" 154 where radiation from the faded edges of one fluence profile 151 add to radiation from adjacent profiles 151 as shown in Fig. 14(c).

By adjusting the overlap of adjacent fluence profiles 151, a compromise can be achieved where the gaps 148 and hot spots 154 are minimized. However, because of the non-linear fluence drop off near the edges 144 of the fan beams 26 (see Fig. 14(b)), stop and shoot beam overlap cannot entirely "smooth" the radiation dose between two adjacent tumor slices.

Machines that can produce a substantially linear fluence drop off at their fan beam edges would make stop and shoot rotation therapy possible. However, without extremely accurate translation and verification systems that provide information on precise patient position within the gantry 14, such machines would not eliminate irradiation gaps or hot spots where an error in patient positioning occurs.

Preferably, therefore a helical scanning pattern is adopted where instead of 360° of gantry rotation in between movement of the patient along the translation axis to the next slice, the patient is continuously

translated during rotation of the gantry so that the axis of radiation describes a helical path through the patient. The pitch of the helix; i.e., the distance the patient traverses along the translation axis 17 for each 360° gantry rotation, may be one slice thickness (the width of the radiation window) so that each slice of the tumor is irradiated from all 360°. Clearly other helical patterns of irradiation could be used. Assuming all beam rays 47 are substantially parallel, each slice may be properly irradiated by a 180° source rotation.

Referring to Fig. 17(a) and 18(a), a simplified tumor 164 of Fig. 16(a) is divided into similarly sized tumor slices, some being referred to as 166, 167 and 168. Referring to Figs. 17(a) and 18(b), in helical scanning during the first 45° of gantry rotation, a collimated beam 172 subtends the front part 171 of the first slice 166 and a dose 173 of radiation is absorbed across the front part 171 of the first slice 166. Referring to Figs. 17(c), as the radiation source 32 rotates from 45° to 180°, one tumor slice is fully exposed and the dose absorbed by the first slice 166 continues to grow.

Referring to Fig. 17(d), as the radiation source 32 rotates from 180° to 225°, the beam 26 begins to subtend parts of both the first and second slices 166, 167 of the tumor 164. The radiation absorbed by the front portion 171 of the first slice 166 begins to level off (see Fig. 18(d)) as the front part 171 of the tumor 164 moves out of the collimated beam 26.

Referring to Fig. 18(e), after a full 360° of rotation, the entire first slice 166 of the tumor 164 has been uniformly irradiated and the gradient absorption is across the second tumor slice 167.

Helical therapy as described above averages the non-uniform fluence profiles 143 of Fig. 16(b) across and between tumor slice 166, 167 to eliminate hot spots 154 and radiation gaps 148.

### VII. Generating Helical Data

The fluence profiles used to operate a therapy machine in a helical manner are not identical to those generated in the planning process described previously. Even though the gantry 14 rotates so that the radiation source 32 directs the fan beam 26 at the tumor site from angles identical to those used in developing the final slice sinograms 101, the position of the patient with respect to the fan beam 26 is typically not the same as that used in developing the sinogram because of the helical motion. Accordingly, during a therapy session, when the collimated fan beam 26 subtends parts of different adjacent tumor slices 166, 167 as in Fig. 17(d), the computer 61 must interpolate between the duty cycle of each leaf 41 for the two adjacent slices 166, 167 to produce a duty cycle approximation for the particular gantry angle  $\phi$  and table position. Again, making the assumption that the rays of the fan beam are substantially parallel a simple weighted averaging calculation using the following equation may be used to generate the duty cycle approximations:

$$\begin{aligned} \Psi(z_i, z_{i+1}, \theta_j, \phi_k) = \\ \Psi(z_i, \theta_j, \phi_k) \left(1 - \frac{\rho}{180}\right) + \Psi(z_{i+1}, \theta_j, \phi_k) \left(\frac{\rho}{180}\right) \end{aligned} \quad (16)$$

where  $z_i$  is the first adjacent slice,  $z_{i+1}$  is a second adjacent slice,  $\theta_j$  is the gantry angle of the radiation source 32,  $\phi_k$  is the compensator leaf angle from the central ray,  $\Psi(z_i, \theta_j, \phi_k)$  is the desired fluence of the first tumor slice commonly irradiated (in Fig. 17(a) slice 166),  $\Psi(z_{i+1}, \theta_j, \phi_k)$  is the fluence of the second tumor slice commonly irradiated (in Fig. 17(a) slice 167),  $\rho$  is a second gantry angle, which is  $0^\circ$  when the fan beam 26 first subtends portions of two adjacent slices and ranges from  $0^\circ$  to  $180^\circ$  as the gantry angle  $\theta_j$  rotates through the next  $180^\circ$ .

In this manner, both the fluence profile of the fan beam 26 and the attenuation of separate beam rays 47 between tumor slices 166, 167 can be made uniform along the length of a tumor 164 to eliminate irradiation gaps and irradiation hot spots.

#### VIII. Imaging Confirmation Mechanism

As described above, the tomographic imaging system 63 operates to generate images used by the computer 61 and image reconstructor 69 to produce fluence profiles for every gantry angle  $\theta$  and every translation table 11 position. In addition, the tomographic imaging system 63 may operate in tandem with the radiation source 32 to confirm the position of the radiation window 24 relative to the tumor. This position check can be used to limit irradiation dose errors either by correcting for patient position changes or by shutting down the machine.

During a therapy planning session, the tomographic imaging system 63 generates and stores raw x-ray attenuation data in the mass storage system 73. Because the table 11 is stationary as the tomographic imaging system 63 rotates about the tumor, the x-ray data generated by the system 63 will differ from that collected during a helical scan.

However, periodically, the helical scanning x-ray beam 29 and detector array 30 will produce data that should be identical to that employed in the therapy planning.

For example, referring to Figs. 17(a) and 17(c), at the 180° rotation point, the irradiation window 172 is centered on the first slice 166 of the tumor 164. Similarly, referring to Fig. 17(e), the irradiation window 172 is also centered on a discrete slice, at the 360° rotation point. At these angles during a helical session, the raw data generated by the tomographic imaging system 63 should coincide with the x-ray data from the same angle generated for the specific slice

during the tomographic imaging portion of the therapy planning session. These angles where data from the planning session and therapy session are identical are referred to herein as coincident angles.

5 Referring to Fig. 19, the raw data generated during the planning session and stored in the mass storage unit 73 is downloaded into a raw data selector 178 which selects the data 180 corresponding to the anticipated coincidence angles. During the therapy session, the  
 10 imaging source 28 and detector array 30 may cooperate to produce only the treatment data 179 necessary to make a position check, the data being generated at the anticipated coincidence angles (in Figs. 17(c) and 17(e) at the 180° and 360° angles where the imaging beam 29  
 15 subtends a distinct tumor slice). A comparator module 182 can then correlate the selected data 180 with the treatment data 179 to generate a difference value 183 according to the following formula:

$$\text{Difference Value} = \sum_{k=1}^n |\psi(\rho, \phi_k) - \psi(t, \phi_k)| \quad (17)$$

20 where n is the number of detector elements in the detector array,  $\psi(\rho, \phi_k)$  is the flux detected at angle  $\phi_k$  during the planning session and  $\psi(t, \phi_k)$  is the flux detected at angle  $\phi_k$  during the therapy session.

A limiter module 184 compares the difference value  
 25 183 to an acceptable limit. If the difference value 183 is not within the acceptable limit range, the limiter module produces an alarm signal. However, if the difference value 183 is not greater or less than the acceptable limit range, the limiter module 184 trips an  
 30 alarm 185 to either shut down the radiation source or alert a therapist of possible patient movement.

#### IX. Software For Controlling Collimator Jaws

All of the fluence profiles for a single gantry rotation are stored together as a sinogram for a "slice"



of the tumor. Referring to Fig. 20, a simplified cylindrical tumor 110 having its axis coincident with the axis of rotation of the gantry 14 has a larger diameter portion 111 and a relatively smaller diameter portion 112. Both large 111 and small 112 diameter portions of the tumor 110 have been divided into separate similarly sized slices 113, 114, 115, 116 and 117.

Referring to Figs. 21(a)-(c), each sinogram of tumor 110 forms a three dimensional surface providing beam width intensity data for each attenuating leaf of the compensator 40 along the vertical axis, gantry angle  $\theta$  along the horizontal axis and leaf number extending back into the page. For a simple homogeneous and cylindrical tumor of Fig. 20, the sinograms will form a two-valued, rectangular plateau. Generally however, the sinograms will be arbitrarily complex two dimensional surfaces.

Referring now to Fig. 22, prior to a therapy session, a comparison module 119 receives all of the sinograms corresponding to the separate tumor slices lying within planes parallel to the fan beam plane 38. After the fluence profiles of the treatment sinograms are determined and stored in the mass data storage system 73, the comparison module 119 compares sinograms for adjacent tumor slices by a correlation process. When two sinograms corresponding to adjacent slices of a tumor are highly correlated, it means that the fluence profiles for both slices are similar for every gantry angle  $\theta$ . Thus, the duty cycles of the compensator leaves 41 are similar for both slices at every gantry angle  $\theta$  and, therefore, similar adjacent tumor slices can be irradiated together minimizing the number of gantry rotations necessary to irradiate a tumor.

For example, referring to Figs. 20, 21 and 22, when tumor 110 is translated into the radiation collimator beam 26 so that the first tumor slice 113 is irradiated by the fan beam 26, the comparison module 119 identifies the sinogram (Fig. 21(a)) stored in the mass data storage

system 73 that corresponds to the first slice 113 and uses it as a comparison standard. The comparison module 119 also identifies the tumor slice 114 adjacent the first tumor slice 113 and next to be irradiated by the thick fan beam 26 and locates its corresponding sinogram (Fig. 21(b)).

The comparison module 119 then correlates these first and second sinograms to create a difference value 120 according to the following formula:

$$10 \quad \text{Difference Value} = \sum_{k=1}^n \sum_{j=0}^{360^\circ} |\psi(z_1, \theta_j, \phi_k) - \psi(z_2, \theta_j, \phi_k)| \quad (18)$$

where  $\psi(z_1, \theta_j, \phi_k)$  is the fluence of the first slice (113) at gantry angle  $\theta_j$  for compensator leaf  $\phi_k$ ,  $\psi(z_2, \theta_j, \phi_k)$  is the fluence of the second tumor slice (114) at gantry angle  $\theta_j$  for the compensator leaf  $\phi_k$ .  $n$  is the number of leaves 41 employed by the compensator 40 and  $360^\circ$  is one gantry rotation. The difference value 120 is a measure of the similarity between sinograms corresponding to the two slices.

A control signal generator 121 compares the difference value 120 to a predetermined limit. If the difference value 120 is below the limit, the control signal generator 121 sets a flag in the mass data storage system 73, via signal 122 indicating that the particular tumor slices can be treated as part of one irradiation zone during a later therapy session.

Referring to Figs. 21(a) and 21(b), the sinograms for the two slices 113, 114 are similar. Therefore, after the comparison module 119 correlates the sinograms of Figs. 21(a) and 21(b) using equation 17, a small difference value 120 results. Therefore, the first two slices 113, 114 of the tumor can be treated as one irradiation zone in a therapy session and the control signal generator 121 provides a signal 122 to that effect.

If the difference value 120 between two sinograms of

adjacent slices 113, 114 is small, the comparison module 119 identifies the third slice 115 to be irradiated by the fan beam thickness 26 and locates its associated sinogram. Comparing the first sinogram (Fig. 21(a)) to  
5 the third sinogram (not shown) a new difference value 120 is generated.

If the new difference value 120 is less also than the limit, the control signal generator 121 provides another control signal 122 to the mass data storage  
10 system 73 indicating that the first 113, second 114 and third 115 tumor slices should be treated as a single irradiation zone during the therapy session. For the tumor in Fig. 20, the third slice 115 is very similar to the first two slices 113, 114 and therefore will have a  
15 similar sinogram and a minimal difference value 120. Therefore, the third slice 115 will be treated together as part of one irradiation zone with the first 113 and second 114 slices.

The correlation process continues with sinograms  
20 corresponding to each next adjacent slice of the tumor 110 being correlated to the comparison standard sinogram until a difference value 120 is found to be greater than the limit.

If any difference value 120 is greater than the  
25 limit, the control signal generator 121 generates a control signal 122 setting a termination flag in the mass storage system. Such a termination flag indicates the last tumor slice is the beginning of a new irradiation zone.

30 For example, referring to the tumor 110 in Fig. 20, when the sinogram (Fig. 21(c)) for the first large diameter slice 116 of the tumor 110 is compared to the sinogram for the comparison standard (Fig. 21(a)) a high difference value 120 results and the control signal  
35 generator 121 stores a terminate flag indicating that the large diameter slice 116 cannot be treated as part of one irradiation zone with the tumor slices proceeding it.

Once an unacceptably large difference value 120 is found and the terminate flag is stored, the comparison module 119 begins the comparison process over again choosing as the comparison standard, the sinogram  
5 corresponding to the last tumor slice 116 that generated the high difference value 120. In Fig. 20, the new comparison standard would be the sinogram corresponding to the first large diameter slice 116 of the tumor 110. The comparison module 119 begins a new set of correlation  
10 calculations correlating the new initial comparison standard (Fig. 21(c)) to the next slice 117 of the tumor to be irradiated following the new initial comparison standard. These comparisons continue until every slice  
15 of the tumor has been associated with some specific irradiation zone of the tumor. An irradiation zone may be a single slice.

A zone map generator 123 communicating with the mass storage unit 73 compresses the irradiation zone data into a value indicating the size of each irradiation zone that  
20 is stored together with one sinogram representative of each irradiation zone.

#### X. Operation of the Collimator Jaws

Referring to Figs. 23(a)-(f), at the beginning of a therapy session shown in Fig. 23(a), the jaws 31a, 31b  
25 are closed so that the opposing faces 249 of the jaws abut a single closed jaw plane 126 positioned at the edge of the collimator beam 3 through which the tumor will first enter. Referring to Fig. 23(b), during a therapy session, a tumor 128 first passes through the back edge 8  
30 of the collimated beam 3 defined by a back jaw 31b and then through the front edge 9 of the collimated beam 3 defined by a front jaw 31a.

As the front edge 125 of a first slice 129 of a tumor 128 is translated into the closed jaw plane 126,  
35 the gantry 14 (not shown in Figs. 23(a)-(f)) begins to rotate moving the radiation source about a rotation axis

118. As the radiation source 32 and jaws 31a, 31b move through one half rotation (Fig. 23(b) and 23(e)), the back jaw 31b moves away from the front jaw 31a, while the front jaw 31a remains stationary with respect to the couch and patient 59 so that the front edge 9 of the collimated beam 3 tracks the position of the front edge 125 of the first slice 129. During the first one half rotation, the first tumor slice 129, moving relative to the back jaw 31b, fully passes through the back edge 8 of the collimated beam 3.

As seen in Fig. 23(e), after the first 180° of gantry rotation, the collimated beam 3 passing through the jaw gap 221 subtends the entire first slice 129 of the tumor 128. From this point on, the jaws 31a, 31b remain at a fixed separation producing a constant jaw gap 221.

It should be appreciated that after a 180° of rotation the amount of cumulative radiation received across the slice 129 is not constant, but rather a gradient. The front edge 125 of the slice 129 has received more radiation than the back edge after the second 180° of rotation is completed, with the front jaw 31a remaining stationary, with respect to the back jaw 31b and the radiation source 32 this gradient is eliminated. The gradient of radiation delivered during the second 180° of rotation is the inverse of the gradient produced by the first half helical rotation, and the two gradients add through the first 360° of helical rotation.

As seen in Fig. 23(c), during the second 180° of rotation of the radiation source 32 around the gantry, the jaws 31a and 31b have constant separation as the tumor 128 is translated through the fan beam thickness 3. The translation speed of the tumor 128 and rotation speed of the gantry 14 are set so that after the second 180° of rotation, the collimated beam 3 passing through the jaw gap 221 subtends the entire second slice 130. At this

point, the entire first slice 129 has been uniformly irradiated. Translation and rotation continues at this ratio, and the jaw gap 221 remains at one slice throughout as many gantry rotations as is required to  
5 irradiate the tumor completely.

In a second embodiment, the collimator control apparatus and sinogram data of the present invention is used to vary the gap size 221 between the collimator jaws 31a, 31b throughout the therapy session. After proper  
10 positioning of the patient 59, and location of the tumor 131 and the loading of the irradiation zone map into the computer 61, the therapy session begins.

Referring to Fig. 24(a), the first slice 137 of the first irradiation zone 142 enters the closed jaw plane  
15 145 defined by the jaws 31a, 31b. The first three slices 137, 138 and 139 of the tumor 130 are to be treated as a single irradiation zone 142, as indicated by the irradiation zone map. Because three slices are to be treated as a single zone 142, the relative translation  
20 speed of the couch 11 may be increased three fold. Thus as seen in Fig. 24(b), during the first 180° of rotation of the radiation source 32, the front jaw 31a moves along with the front edge 140 of the first irradiation zone 142 at the increased couch speed while the back jaw 31b  
25 remains stationary with respect to the radiation source. The entire first irradiation zone 142 (i.e. slices 137, 138, 139) passes through the back edge 8 of the collimated beam 3 defined by the back jaw 31b by the time the first 180° of helical rotation has been completed.  
30 At this point the collimated beam 3 passing through the jaw gap 221 subtends the entire first irradiation zone 142.

During the second 180° of helical rotation, translation of the couch 11 remains at the increased  
35 speed and the front jaw 31a remains stationary with respect to the source 32 while the back jaw 31b is moved toward the front jaw 31a at the increased couch speed.

Referring to Figs. 25(c) and 25(f), the back jaw 31b tracks the back edge of the collimated beam 3 to the back edge 141 of the first irradiation zone 142. At the end of the second 180° of helical rotation, the jaws 31a, 31b are closed and the back edge 141 of the first irradiation zone 142 abuts the closed jaw plane 145.

During the third 180° of helical rotation, the process above starts over again for the second irradiation zone 136 (i.e. the zone having a relatively larger diameter seen in Figs. 24(a)-(f)) with the couch speed and maximum size jaw gaps 221 adjusted to reflect the size of the second irradiation zone 136.

The above description has been that of a preferred embodiment of the present invention. It will occur to those who practice the art that many modifications may be made without departing from the spirit and scope of the invention. For example, a computed tomography system need not be incorporated with the radiation therapy equipment but separate such equipment could be used.

It should also be understood that other, more complex, algorithms could be developed to enable the jaws 31a, 31b to remain apart during an entire therapy session (i.e., not fully closing between irradiation zones). In the alternative, algorithms could be developed that close the jaws 31a, 31b at the end of large irradiation zones, but remain open at a single tumor slice thickness linearly interpolating between adjacent sinograms in areas where irradiation zones are of some predetermined minimal size.

Another possible variation that should be recognized is that a full helical rotation may be used to open the jaws 31a, 31b to a position in which the collimated beam 3 fully radiates an irradiation zone. In fact, in many applications a full helical rotation is desirable so that each part of an irradiation zone is irradiated from a full 360°.

Also, the method for planning radiation therapy is

not limited to a particular radiation source but may be used with any radiation source which may be decomposed into separately attenuated radiation slices.

In yet another variation, the therapy planning  
5 tomographic data may be generated in helical form to effect a more perfect match between that data and the imaging data collected during an irradiation session. Such data could be used to perform a constant position check on the patient and tumor during a therapy session,  
10 In addition, the x-ray source 28 and radiation source 32 may be configured so as to be in a single plane.

In order to apprise the public of the various embodiments that may fall within the scope of the invention, the following claims are made:



CLAIMS

We claim:

1. A radiation therapy machine for treating a patient with high energy radiation comprising:
  - a gantry for rotation within a gantry plane;
  - a table disposed along an axis of translation for
  - 5 supporting a patient and for moving the patient along the axis of translation, the axis of translation positioned within the rotation of the gantry;
  - a radiation source disposed on the gantry for producing a radiation beam within a fan beam plane
  - 10 substantially parallel to the gantry plane, the beam including a plurality of rays diverging in the beam plane about one central ray, the central ray directed at the patient from a variety of gantry angles along the gantry plane; and
  - 15 an attenuation means disposed between the radiation source and the patient for independently controlling the intensity of each ray as a function of gantry angle.
  
2. The radiation therapy machine as recited in claim 1 also including an annular, stationary radiation shield disposed around the gantry so as to stop scattered radiation from the radiation source after the radiation
- 5 passes through the patient.
  
3. The radiation therapy machine as recited in claim 1 also including a beam stopper that rotates about the gantry opposite the radiation source, the beam stopper subtending and occluding radiation from the
- 5 radiation source after the radiation passes through the patient.

4. A radiation therapy machine for treating a patient having a treatment volume, the machine comprising:

a gantry for rotation within a gantry plane;

5 a radiation source disposed on the gantry for rotation with the gantry about an axis of rotation, the radiation source directing a radiation beam toward the axis of rotation from a plurality of first gantry angles along the gantry plane;

10 an x-ray source disposed on the gantry for producing an x-ray beam directed toward the axis of rotation from a plurality of second gantry angles solely along the gantry plane, the radiation source and the x-ray source positioned in separate parallel planes so that the  
15 radiation beam and x-ray beam do not intersect; and

an x-ray detector disposed on the gantry and diametrically opposed to the x-ray source for receiving the x-ray beams therefrom.

5. A radiation therapy machine having a radiation source directing a radiation beam toward a patient with a treatment volume at a plurality of angles within a gantry plane, the beam including a plurality of adjacent rays diverging about one central ray, the beam, when not occluded, subtending a radiation window on the patient, the radiation machine comprising:

5 a table disposed along an axis of translation for supporting a patient and for moving the patient along the axis of translation; and

10 a motivation means for moving the radiation source around an axis of rotation during motion of the table along the axis of translation;

15 whereby, the central ray sweeps a helical path through the patient.

6. The radiation machine as recited in claim 5 wherein the patient is translated by a fraction of the width of the radiation window along the translation axis for every  $2\pi$  of rotation of radiation source about the axis of rotation.

7. The radiation machine as recited in claim 5 including an attenuation means disposed between the radiation source and the patient for independently controlling the intensity of each ray of the beam.

8. A radiation therapy apparatus, having a radiation source for directing a beam of radiation along a beam plane and including a plurality of rays diverging in the beam plane about a central ray, the beam of radiation directed at a patient having a treatment volume, the beam, when not occluded, illuminating a radiation window on the patient, the apparatus comprising:

an attenuating means disposed between the radiation source and the patient for independently controlling the intensity of the rays of the beam;

a first and second radiopaque jaw disposed within the beam and substantially parallel to the beam plane for moving together and apart, the jaws, when together, occluding the beam and when apart, defining a collimated beam, the first jaw defining a first collimated beam edge and the second jaw defining a second collimated beam edge;

a translation means for moving the treatment volume along a translation axis with respect to the beam plane wherein relative motion between the treatment volume and the beam plane causes the treatment volume to first pass through the first collimated beam edge and second pass through the second collimated beam edge;

jaw motivation means for independently moving the opposing edges of the first and second jaws together and apart within the beam to control the thickness of the collimated beam passing therebetween as a function of the relative position of the radiation window with respect to the treatment volume.

9. The apparatus as claimed in claim 8 wherein the jaw motivation means includes:

a position indicating means for determining the position of the radiation window relative to the treatment volume;

a control means receiving position information from the position indicating means and controlling the jaws so that:

- 5 a) the jaws occlude the fan beam when the radiation window does not overlap the treatment volume;
- b) the first jaw moves away from the second jaw and the first jaw is fixed in position with respect to the treatment volume when the treatment volume first crosses the first beam edge but prior to the separation  
10 between the jaws exceeding a predetermined maximum; and
- c) the second jaw moves toward the first jaw until the opposing faces of the first and second jaws are together and the second jaw is fixed in position with respect to the treatment volume when the treatment volume  
15 last crosses the second beam edge.

10. The apparatus as claimed in claim 9 wherein the position indicating means calculates the position of the treatment volume relative to the radiation window by relating a known position of the treatment volume within  
5 the patient and a known position of the patient on the translation means to a known displacement of the translation means relative to the radiation source.

11. The apparatus as claimed in claim 8 wherein the jaw motivation means controls the first and second jaws so that:

5 prior to the treatment volume first overlapping the radiation window, a plane defined by the closed jaws where the closed jaws are parallel to an adjacent fan beam ray, is at the edge of the radiation window first crossed by the treatment volume; and

10 subsequent to the treatment volume last overlapping the radiation window the plane defined by the closed jaws is at the edge of the radiation window last crossed by the treatment volume.

12. The apparatus as claimed in claim 8 wherein the radiation source is attached to a gantry for rotation of the central ray about a rotation axis to direct the radiation beam at the treatment volume from a plurality  
5 of angles.

13. A radiation therapy machine having a radiation source for directing a beam of radiation along a beam plane toward a patient with a treatment volume, the therapy machine including a collimator disposed between  
5 the radiation source and the patient, to control the beam width normal to the beam plane, the machine including a means for supporting and moving the patient with respect to the beam plane along a translation axis wherein the treatment volume includes a plurality of adjacent slices,  
10 each slice associated with a sinogram, indicating desired fluence profiles to be directed toward one associated slice, the machine comprising:

a comparison means for comparing sinograms of adjacent slices to generate a difference value;

15 a control signal means receiving the difference value from the comparison means for indicating whether the difference value is within a predetermined limit by means of a correlation signal;

20 a collimator control means receiving the correlation signal from the control signal means for controlling the collimator to adjust the beam width to simultaneously irradiated adjacent slices of the treatment volume when the correlation signal indicates that the difference value is within the predetermined limit.

14. The apparatus as claimed in claim 13 wherein the collimator includes a first collimator jaw and a second collimator jaw to control the width of the beam.

15. The apparatus as claimed in claim 14 wherein each sinogram comprises profiles for a plurality of gantry angle for an associated slice and whereby the comparison means compares profiles of adjacent sinograms  
5 at corresponding gantry angles and combines the values of the comparisons to produce the difference value.

16. A method to be used with a radiation therapy machine, the therapy machine having a radiation source for producing a fan beam of radiation lying generally in a fan beam plane and directed at a patient with a treatment volume, the beam consisting of a plurality of adjacent beam rays, the treatment volume divided into a plurality of adjacent slices to be translated through the fan beam plane, the machine having a first and second radiopaque jaw disposed within the fan beam having opposed edges parallel to the beam plane, the jaws, when together, defining a closed jaw plane and when apart, forming a collimated beam, the first jaw defining a first collimated beam edge and the second jaw defining a second collimated beam edge, the therapy machine including a couch for supporting and translating the patient through the beam plane, the method comprising the steps of:

analyzing the slices to define at least one irradiation zone including substantially similar adjacent slices and having a thickness equal to the sum of the thickness of the similar adjacent slices;

translating the treatment volume past the closed jaw plane; and

moving the jaws together and apart within the fan beam to change the thickness of the collimated beam passing therebetween to correspond with the thickness of the irradiation zone.



1/17

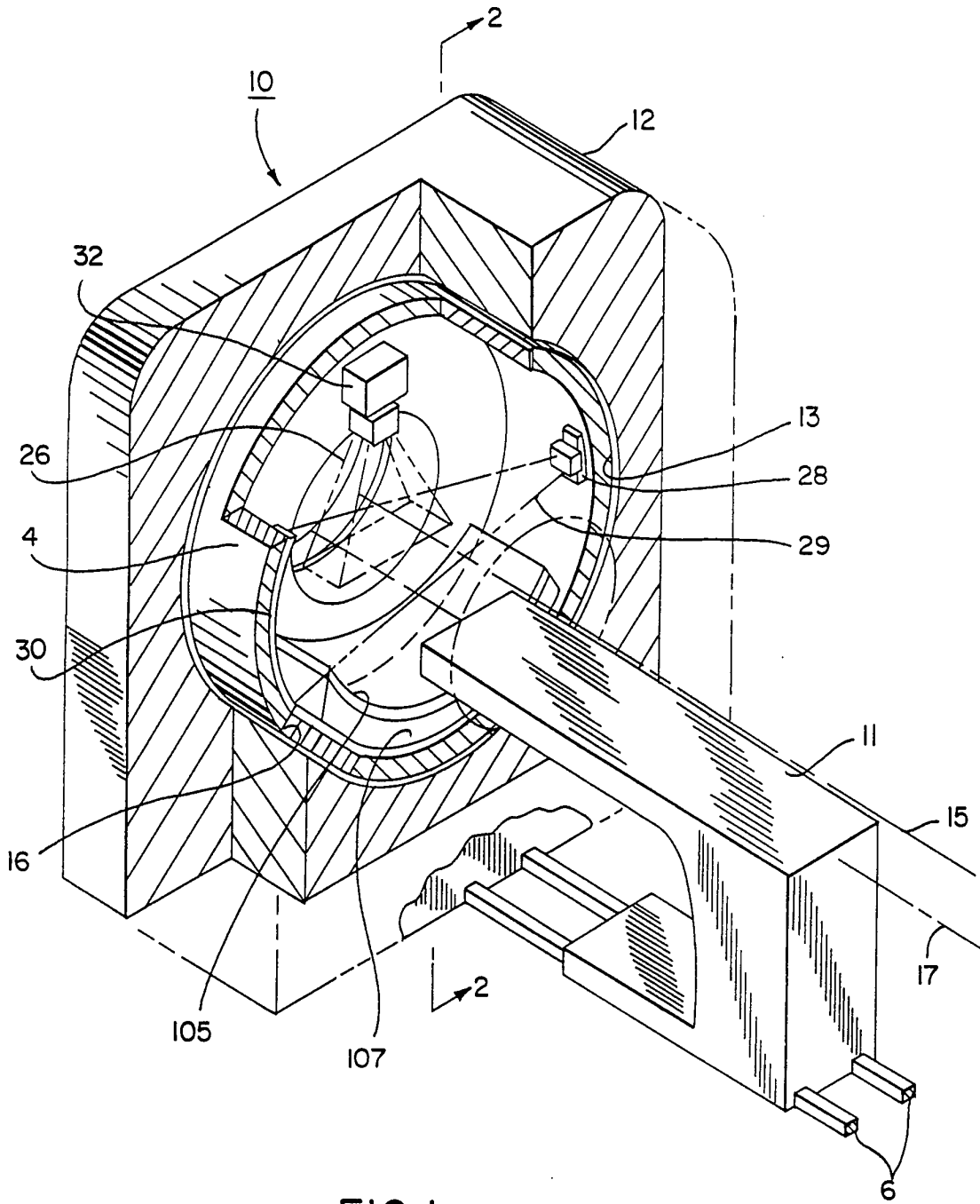
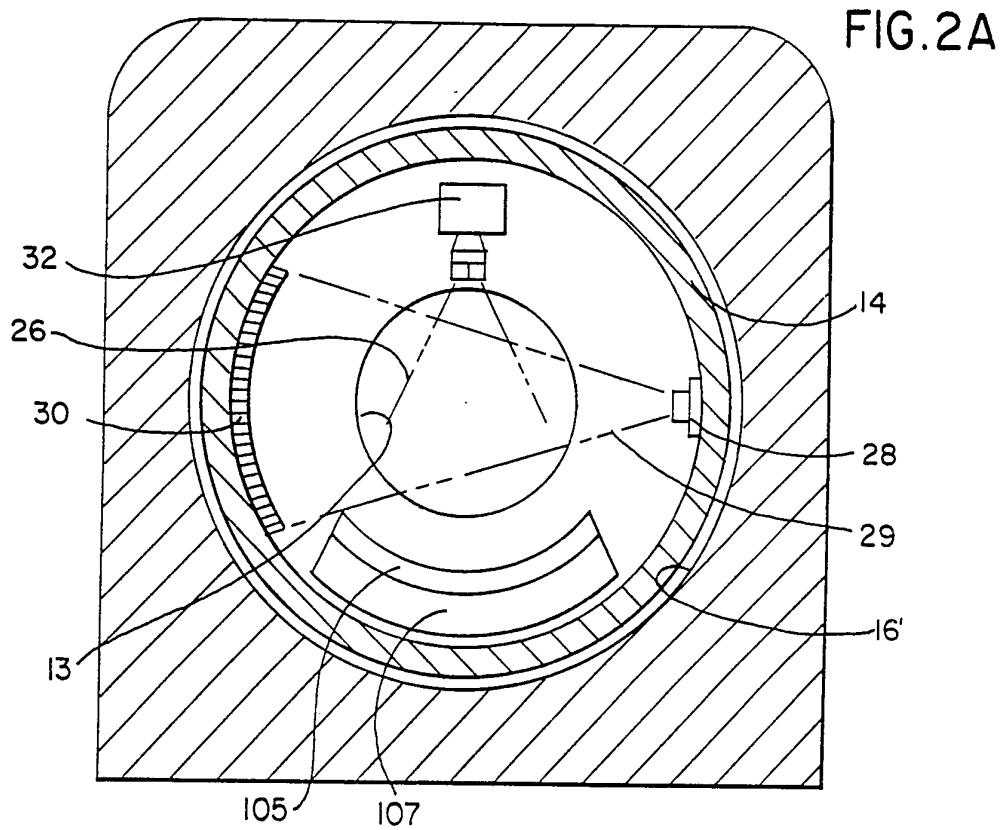
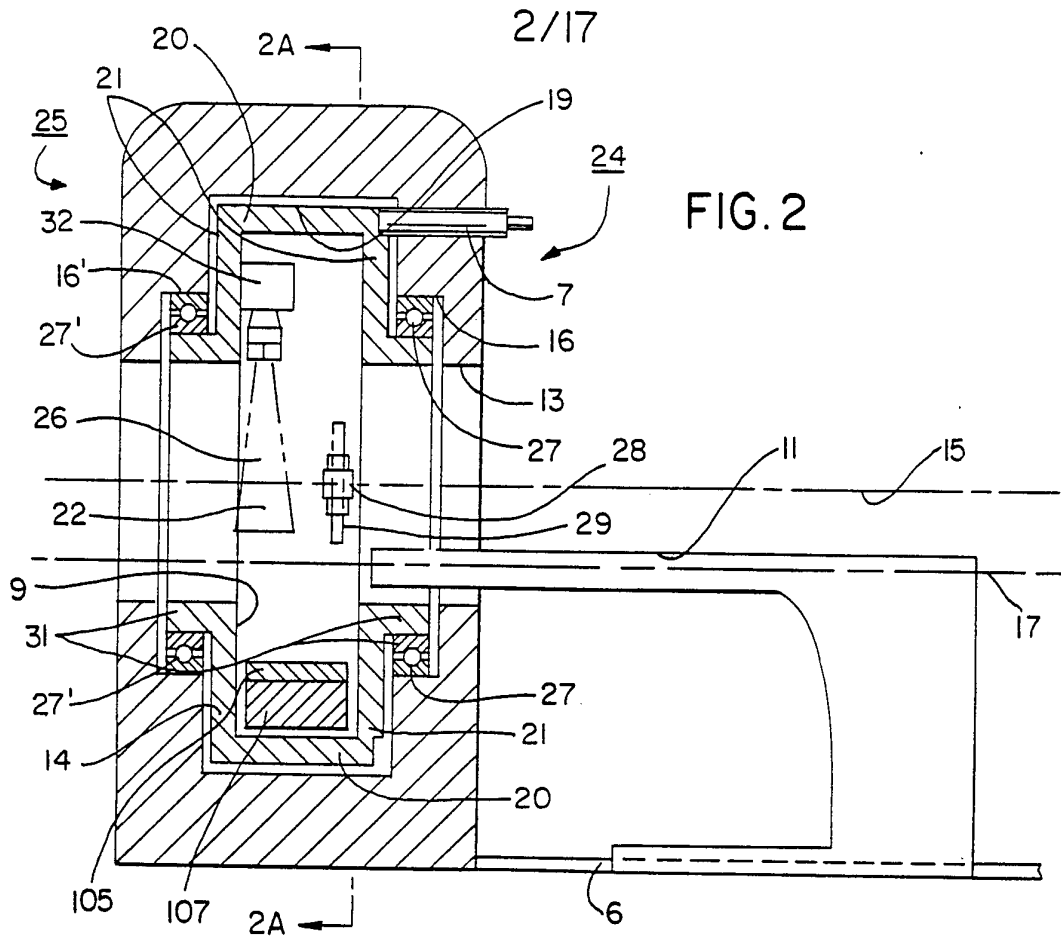

FIG. 1



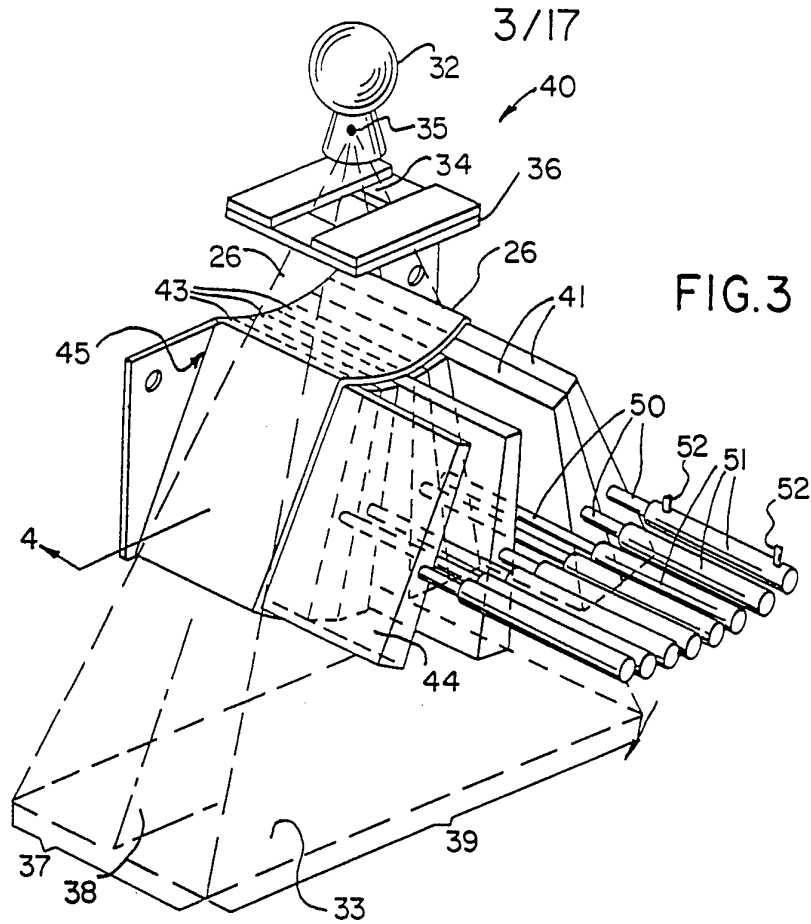

FIG. 3

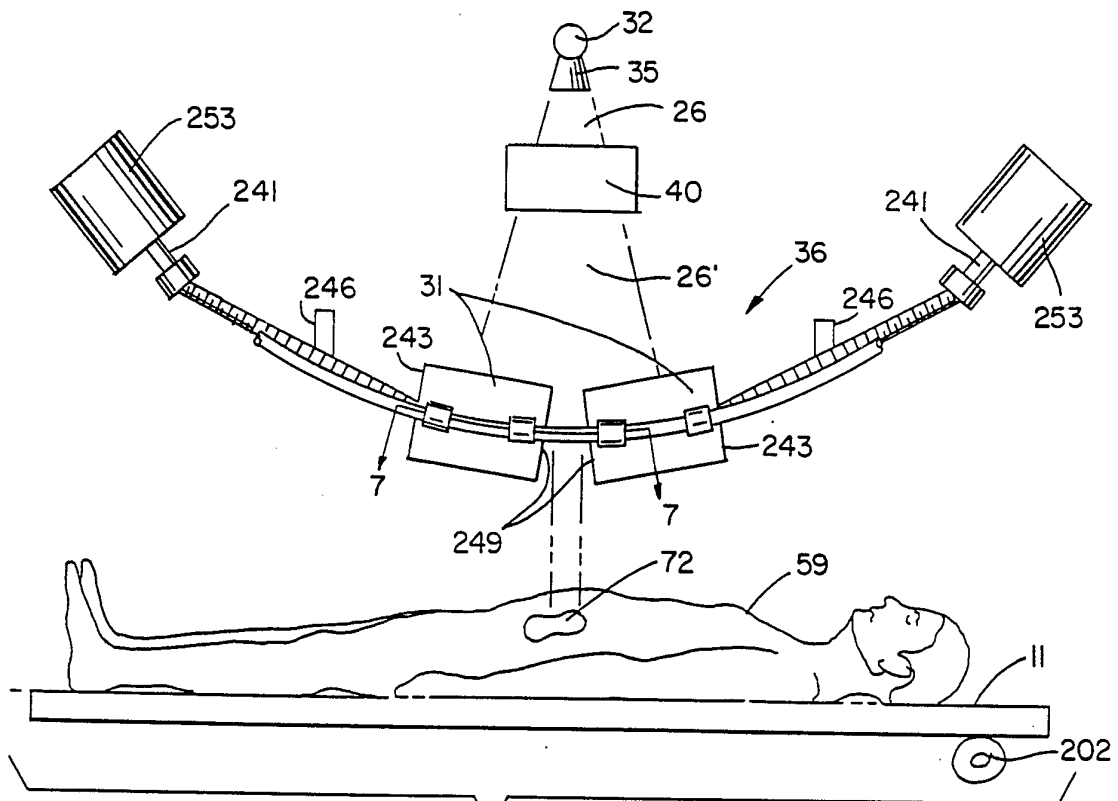
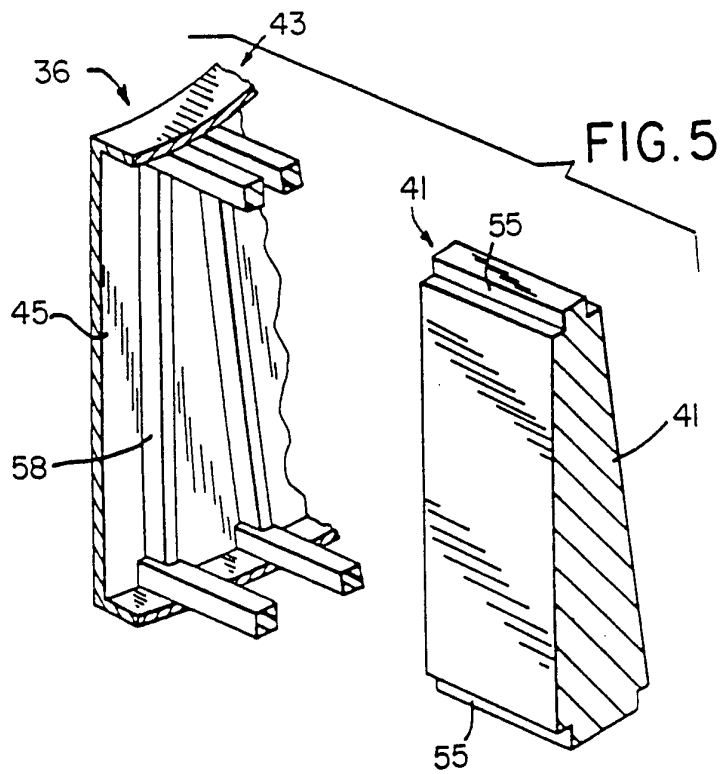
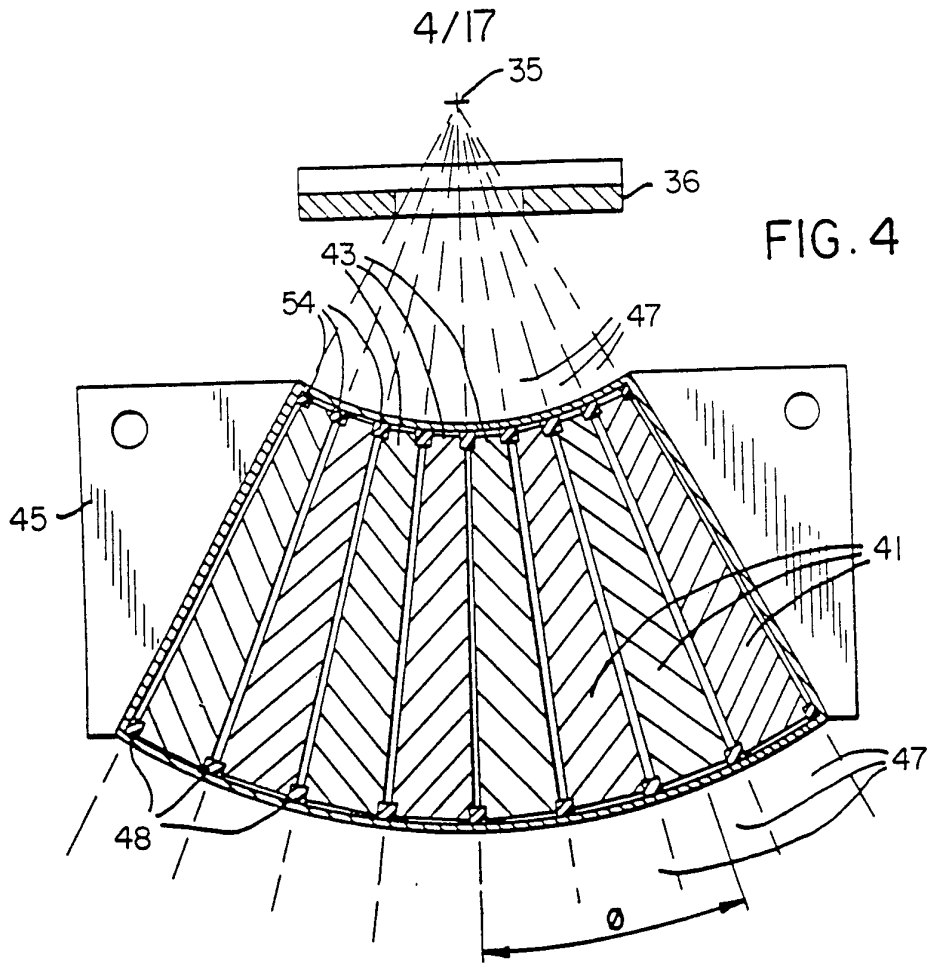

FIG. 6



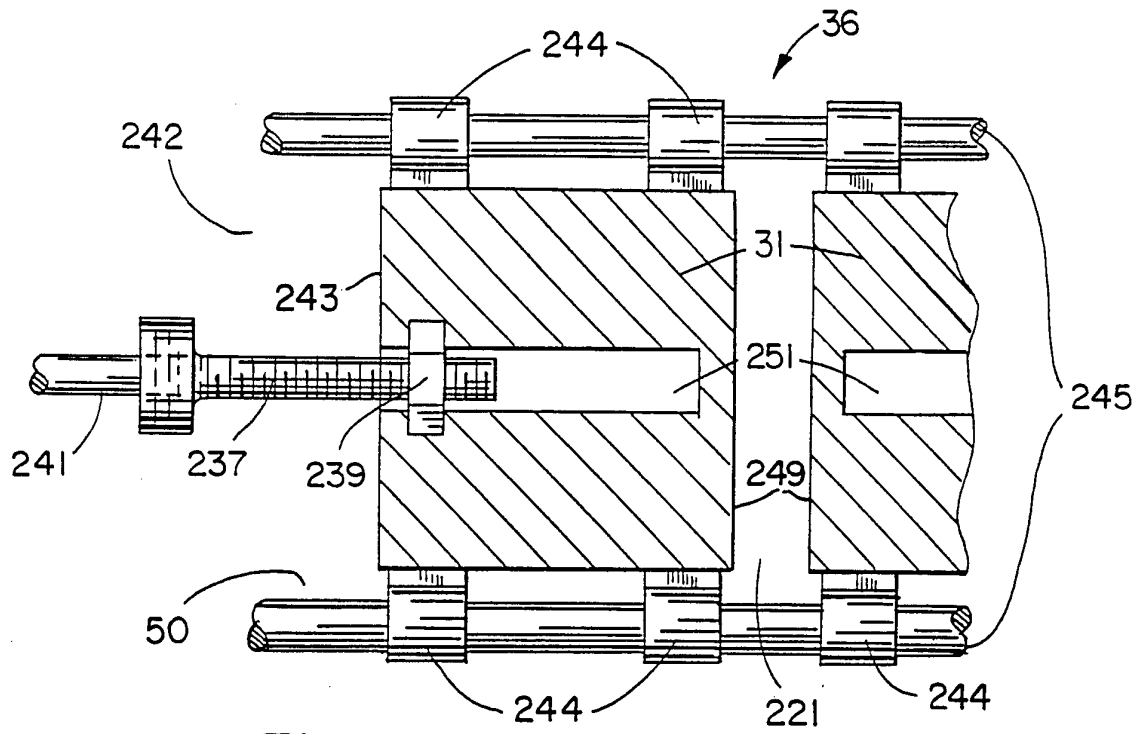

FIG. 7

6/17

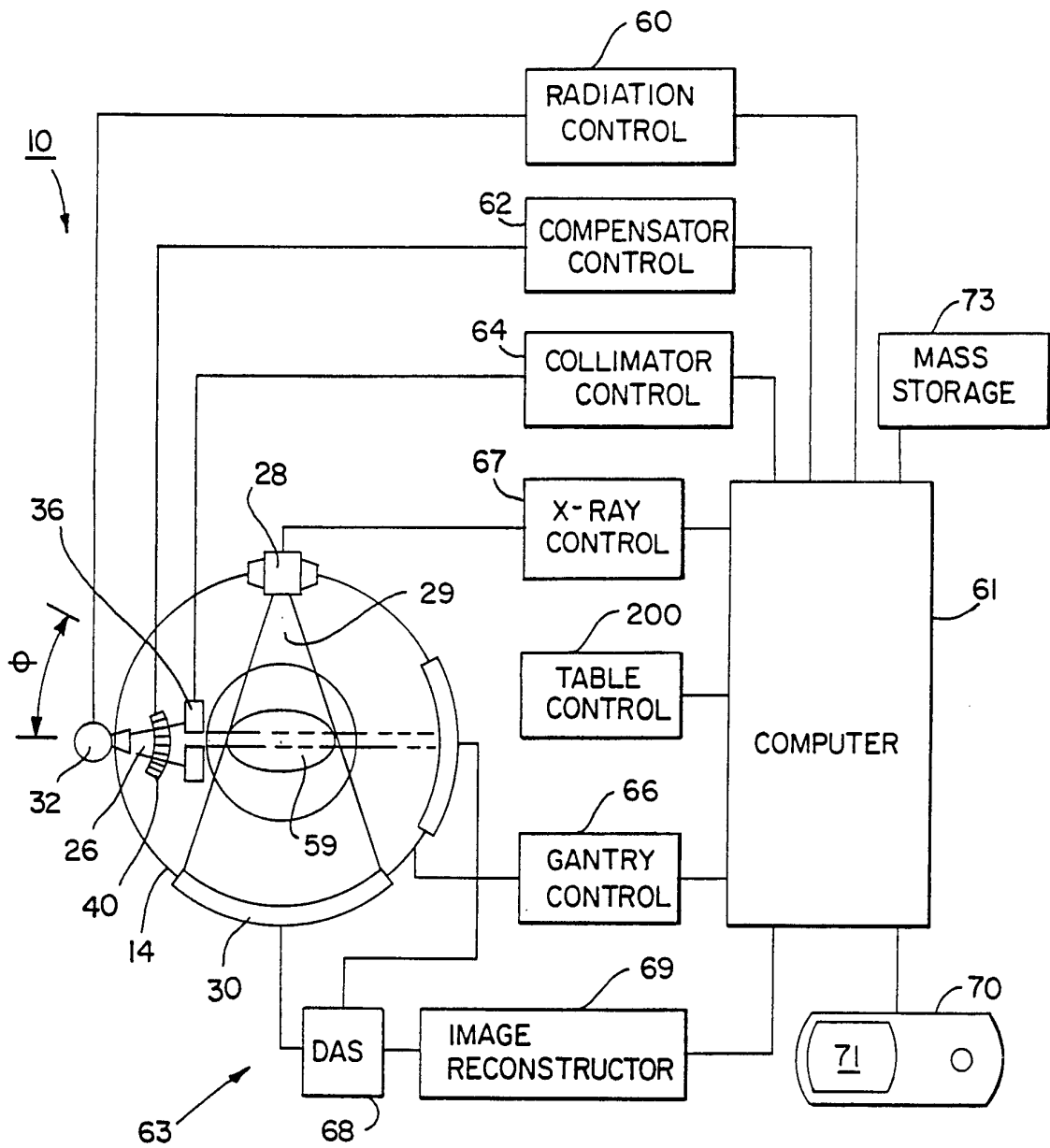

FIG. 8

7/17

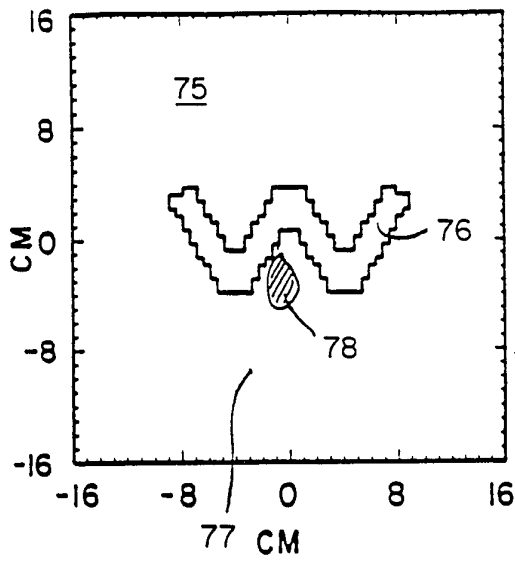

FIG. 9A

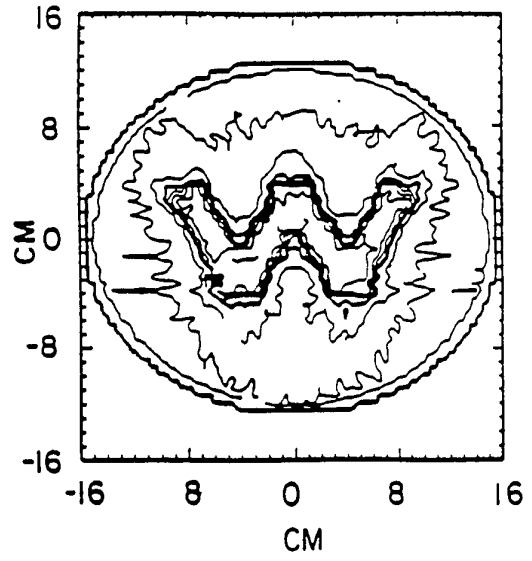

FIG. 9B

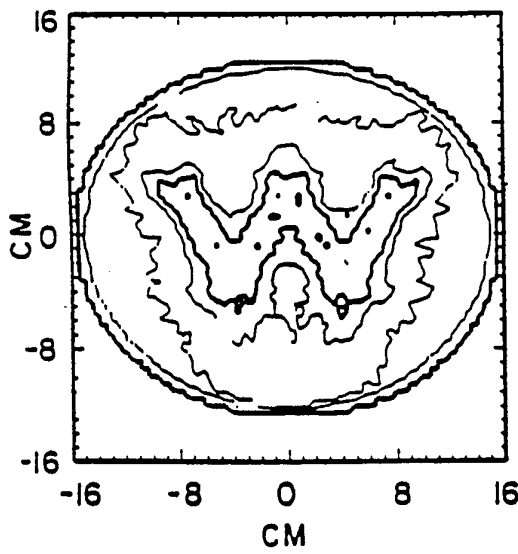

FIG. 9C

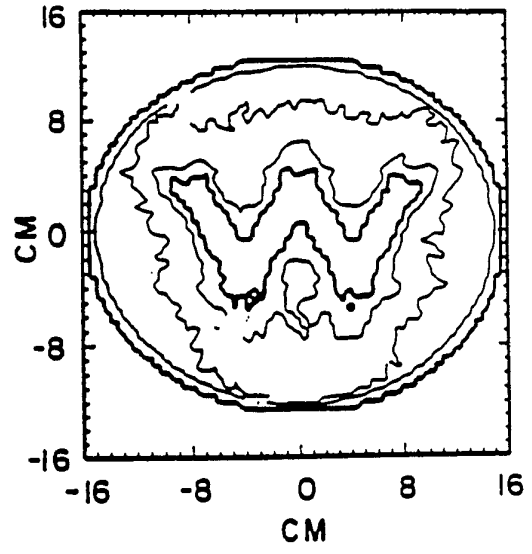

FIG. 9D

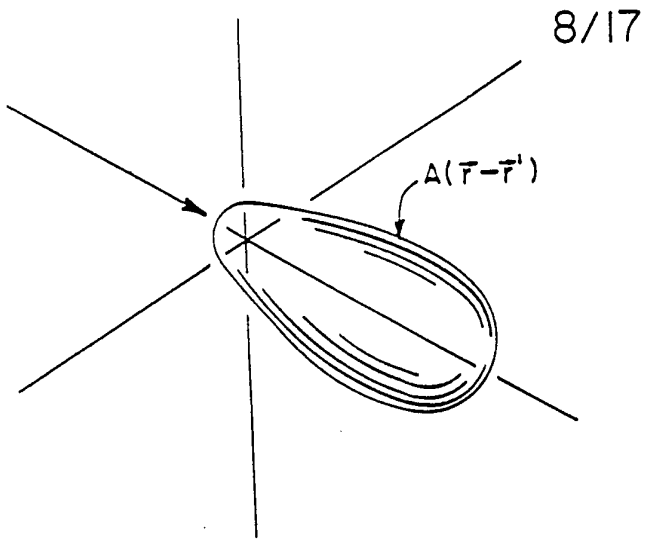

FIG. II

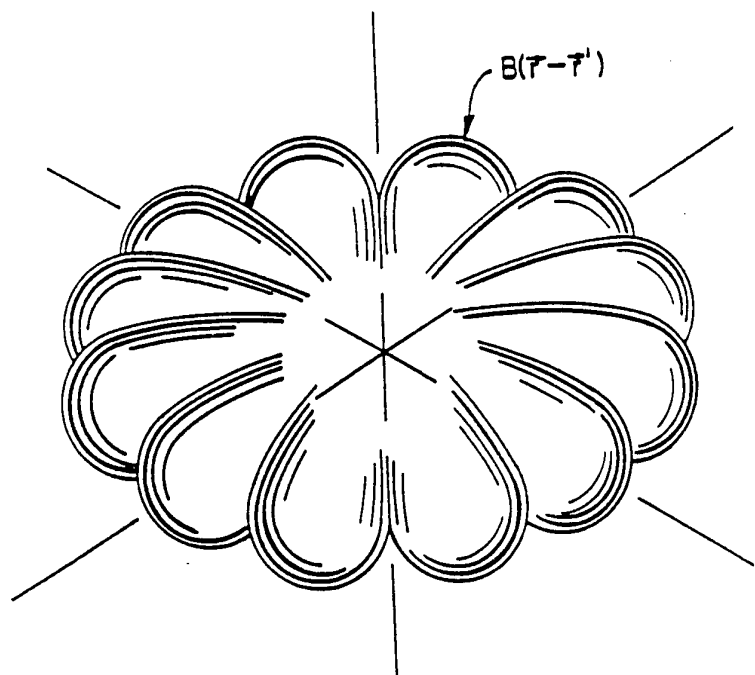

FIG. 12

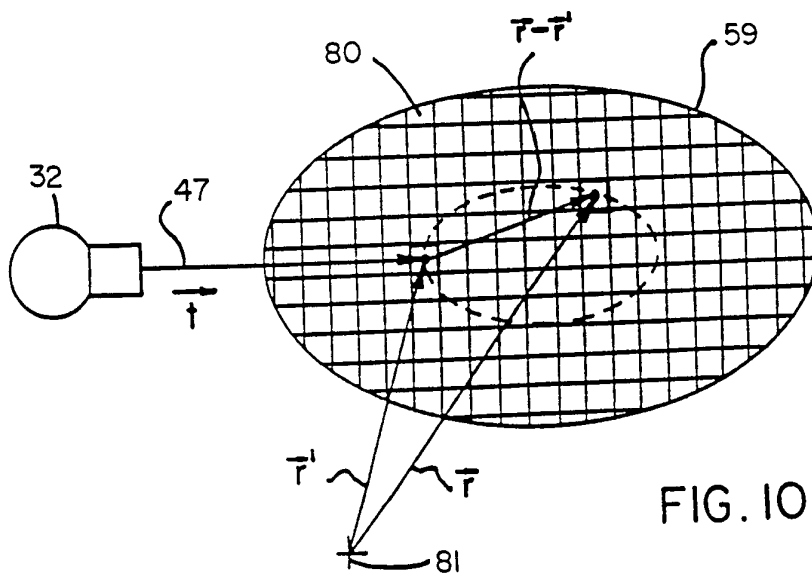

FIG. 10



9/17

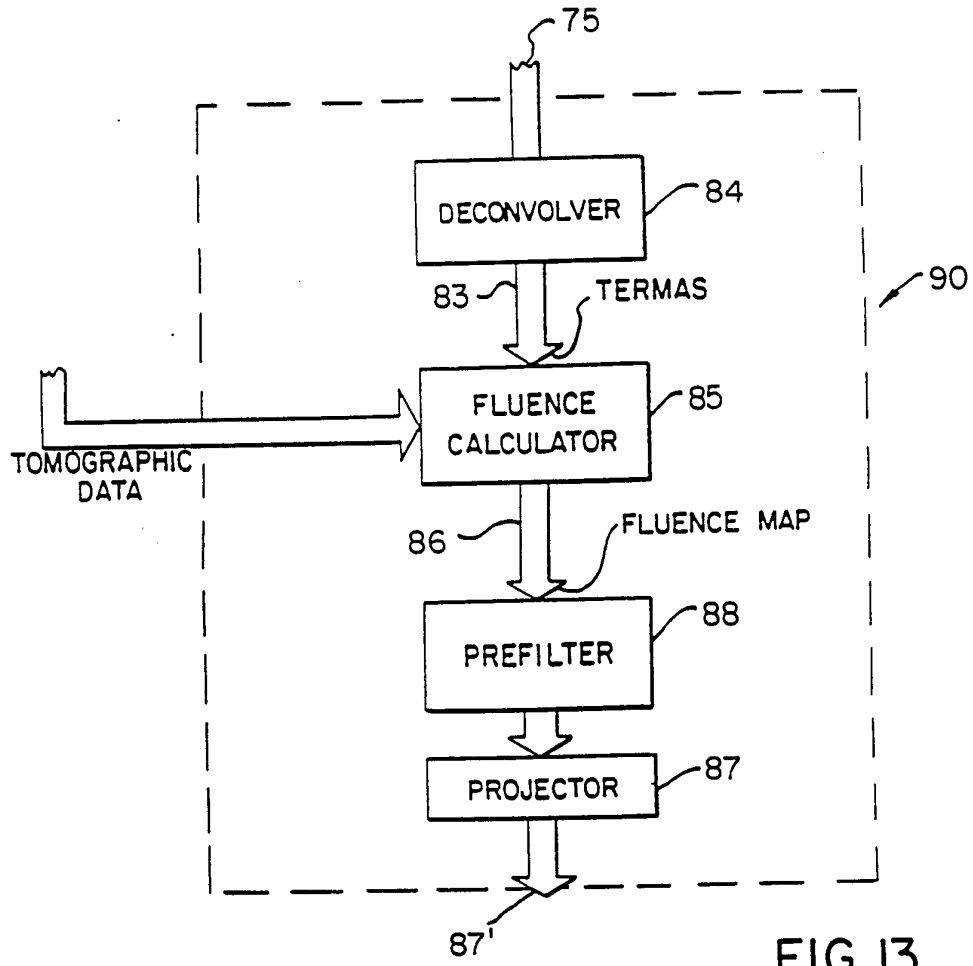

FIG.13

10/17

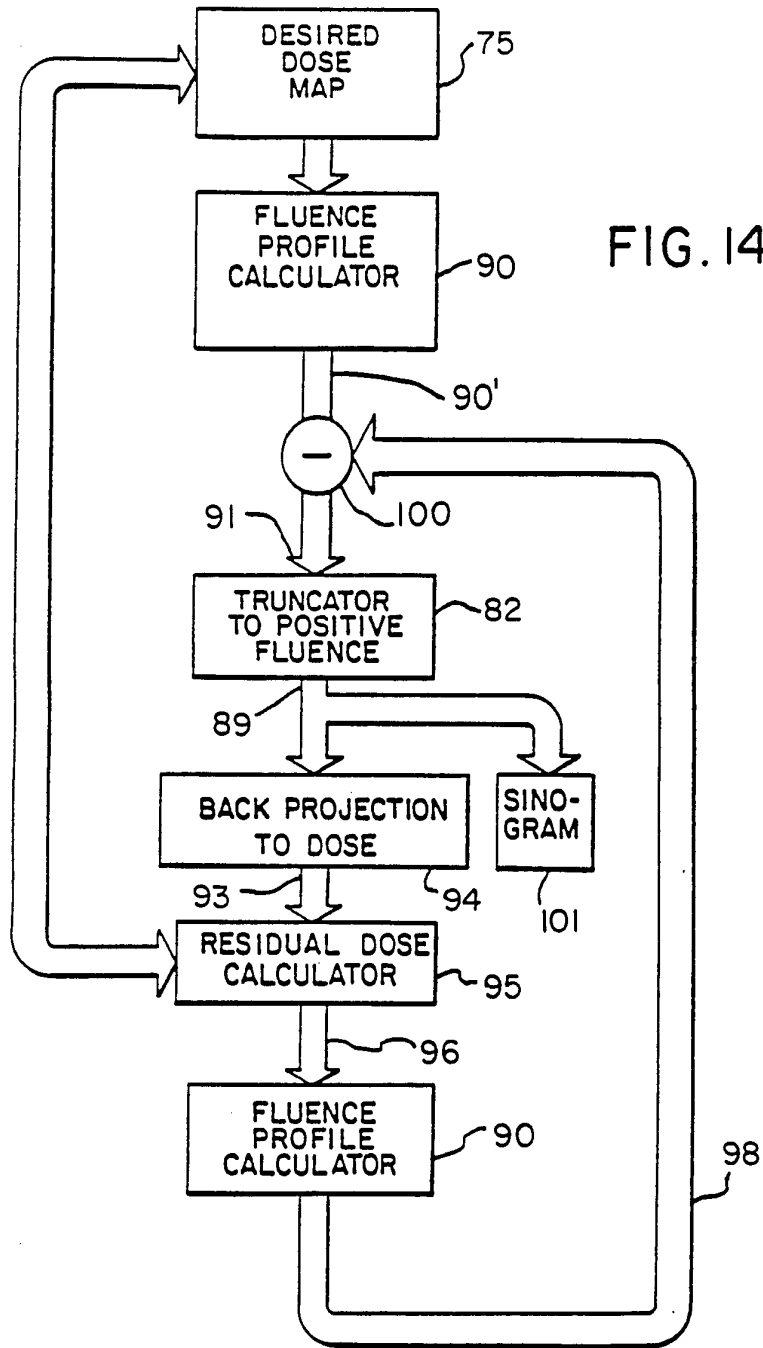

FIG. 14

11/17

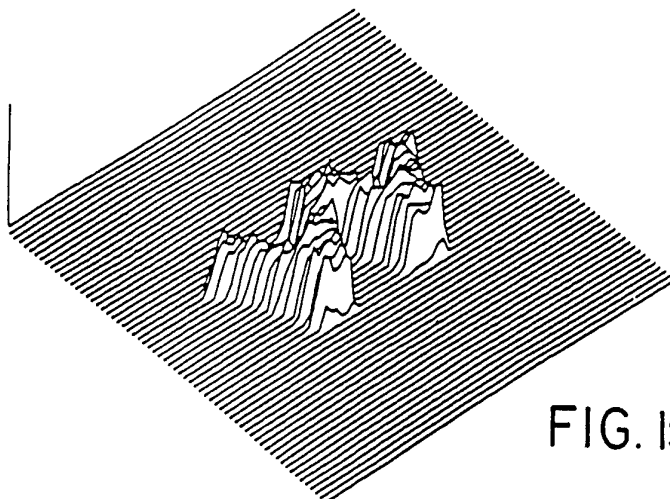

FIG. 15A

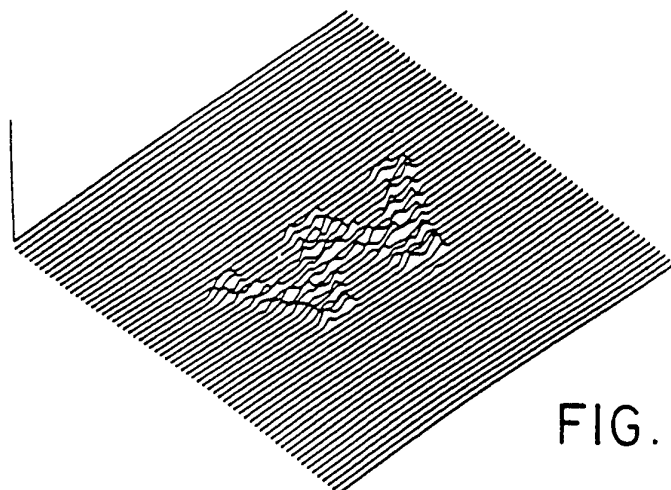

FIG. 15B

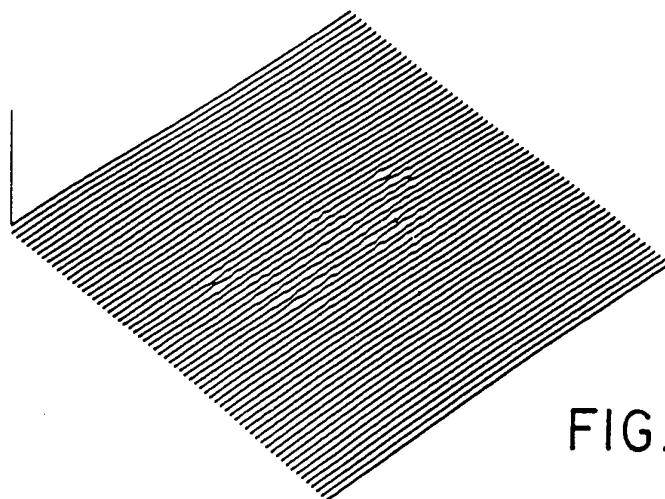
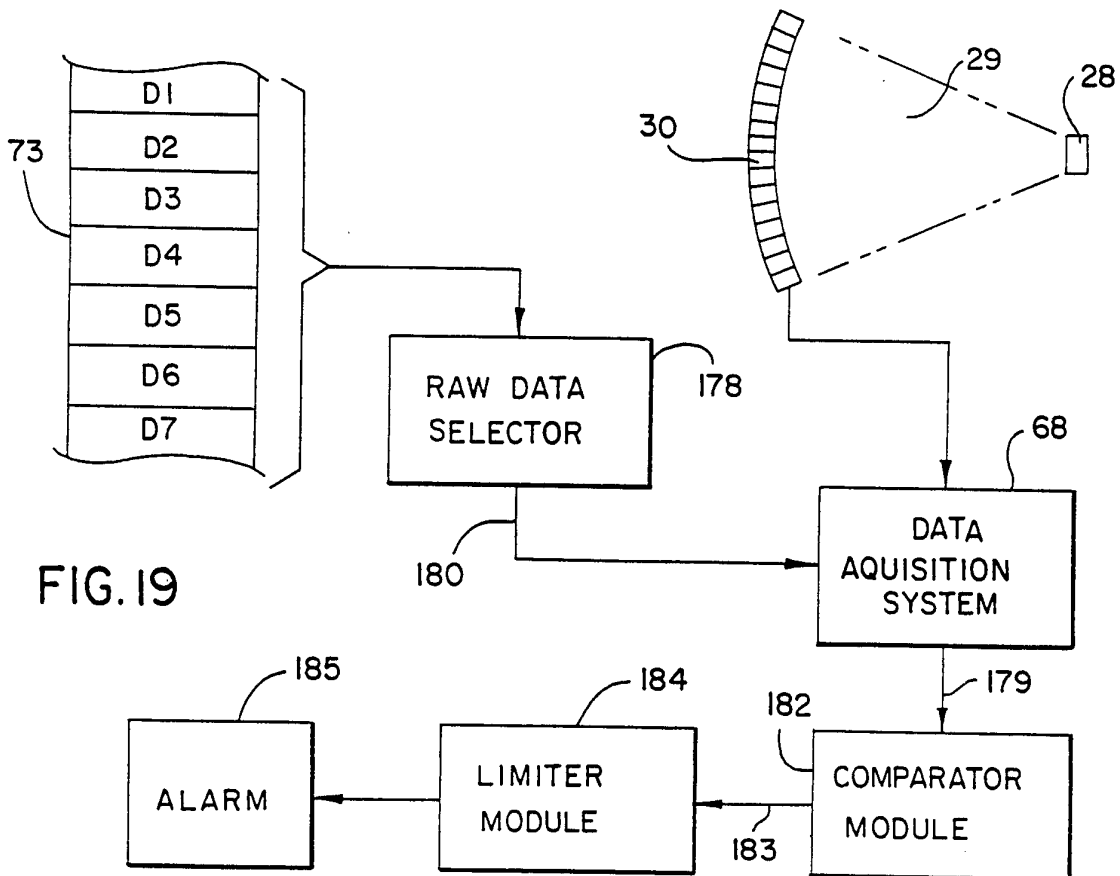
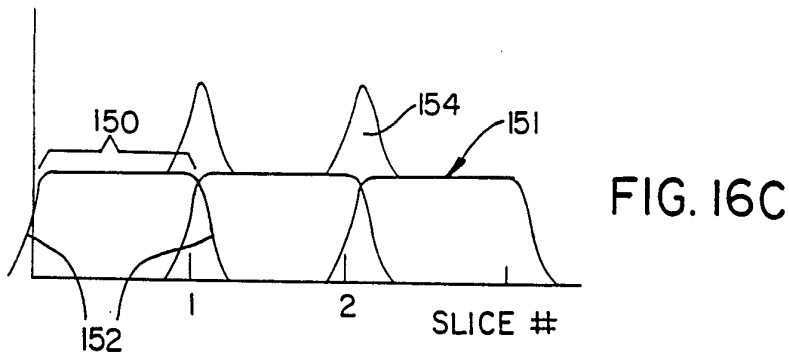
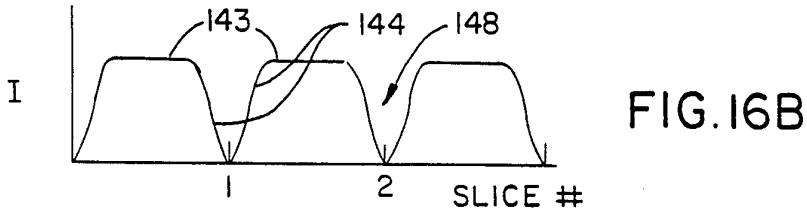
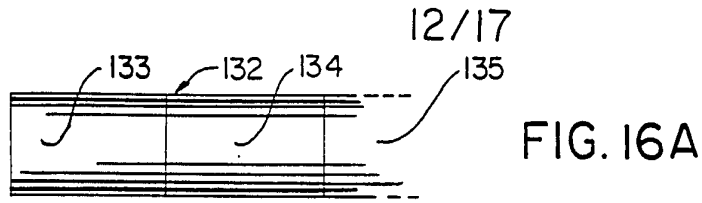

FIG. 15C



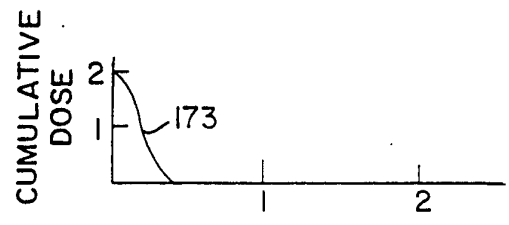
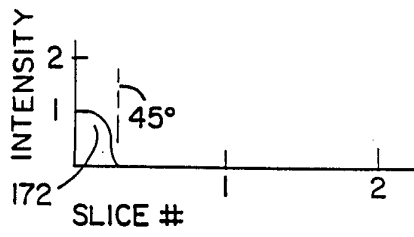
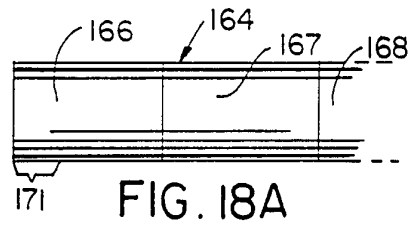
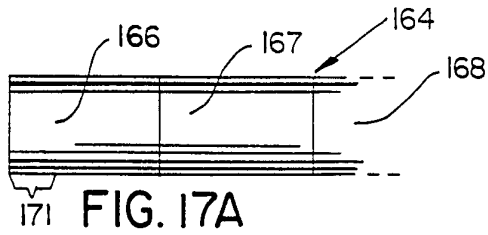

FIG. 17B

FIG. 18B

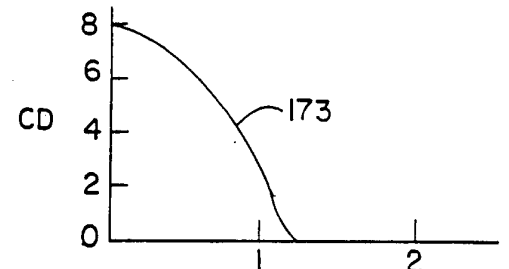
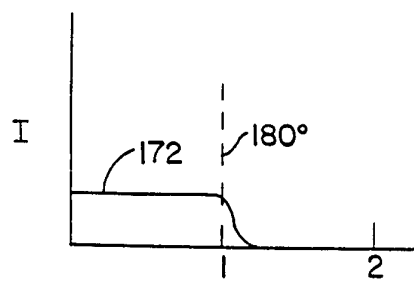

FIG. 17C

FIG. 18C

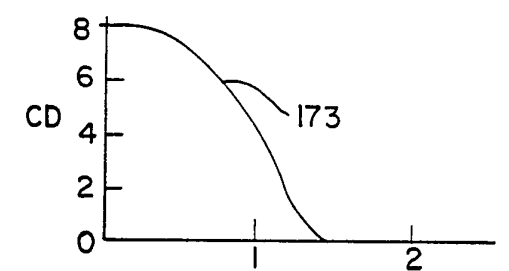
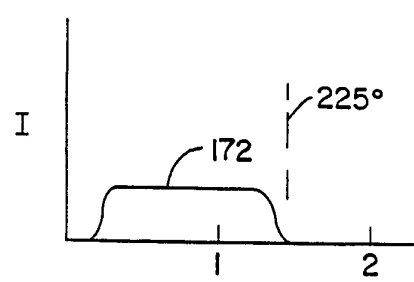

FIG. 17D

FIG. 18D

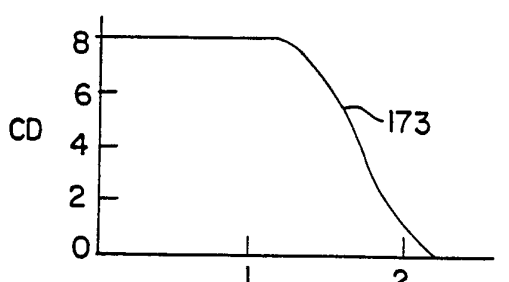
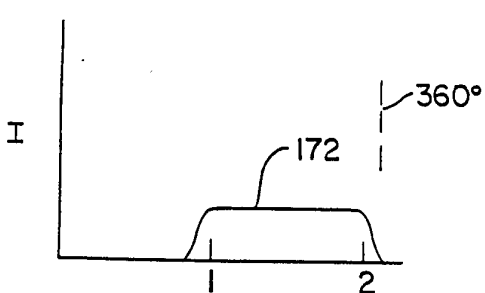
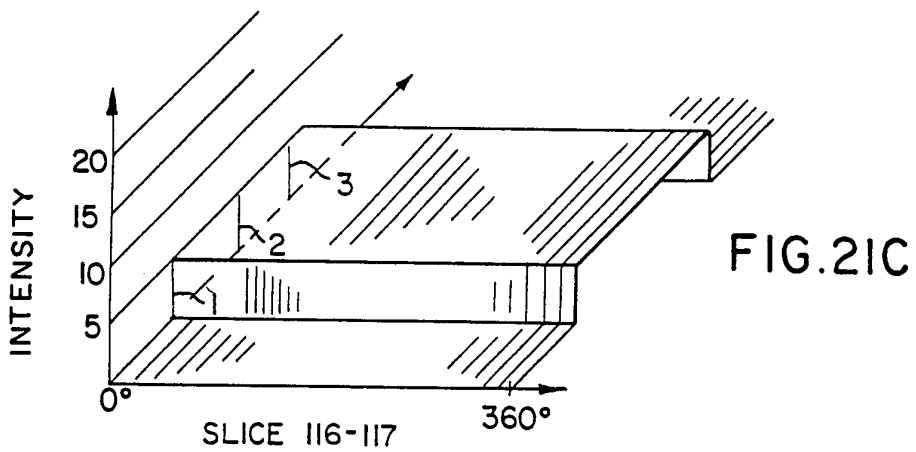
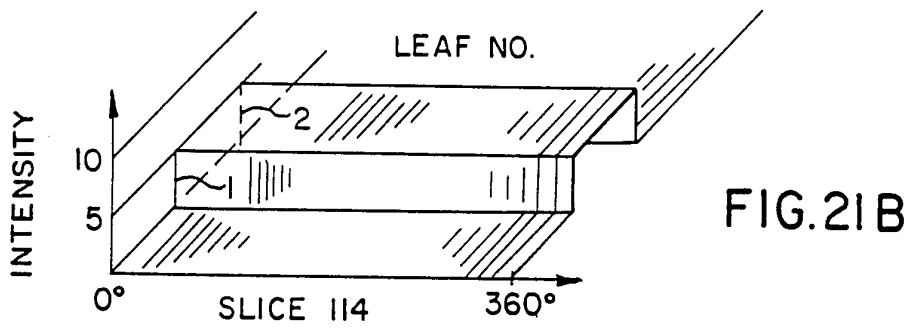
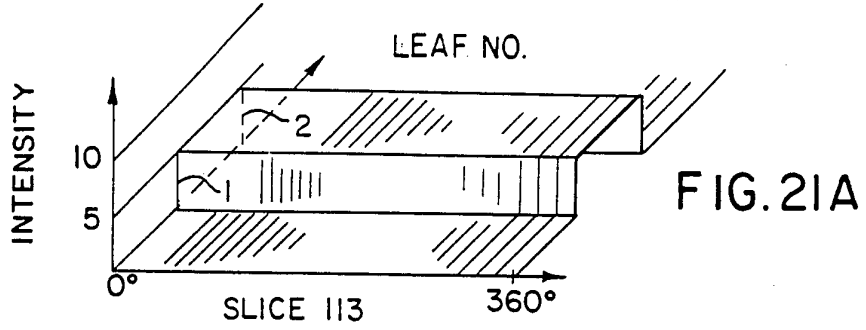
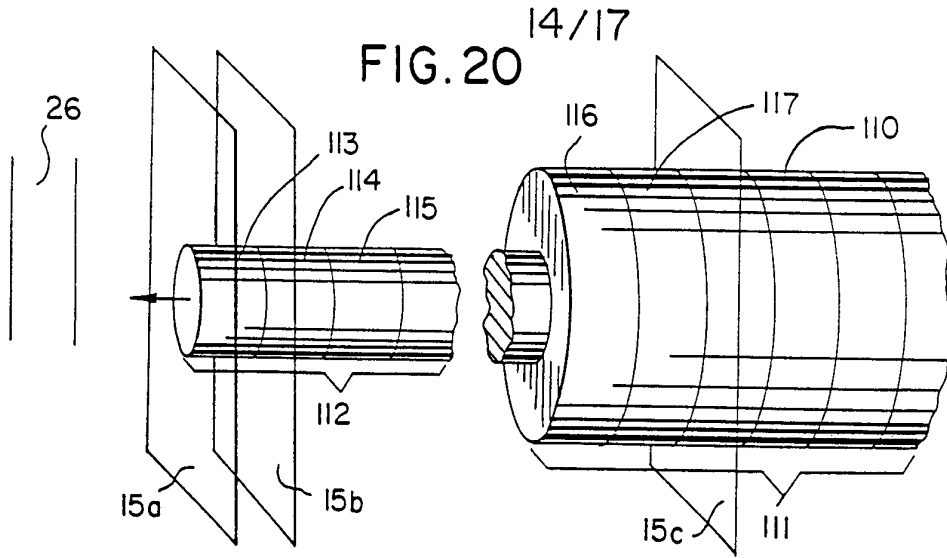

FIG. 17E

FIG. 18E



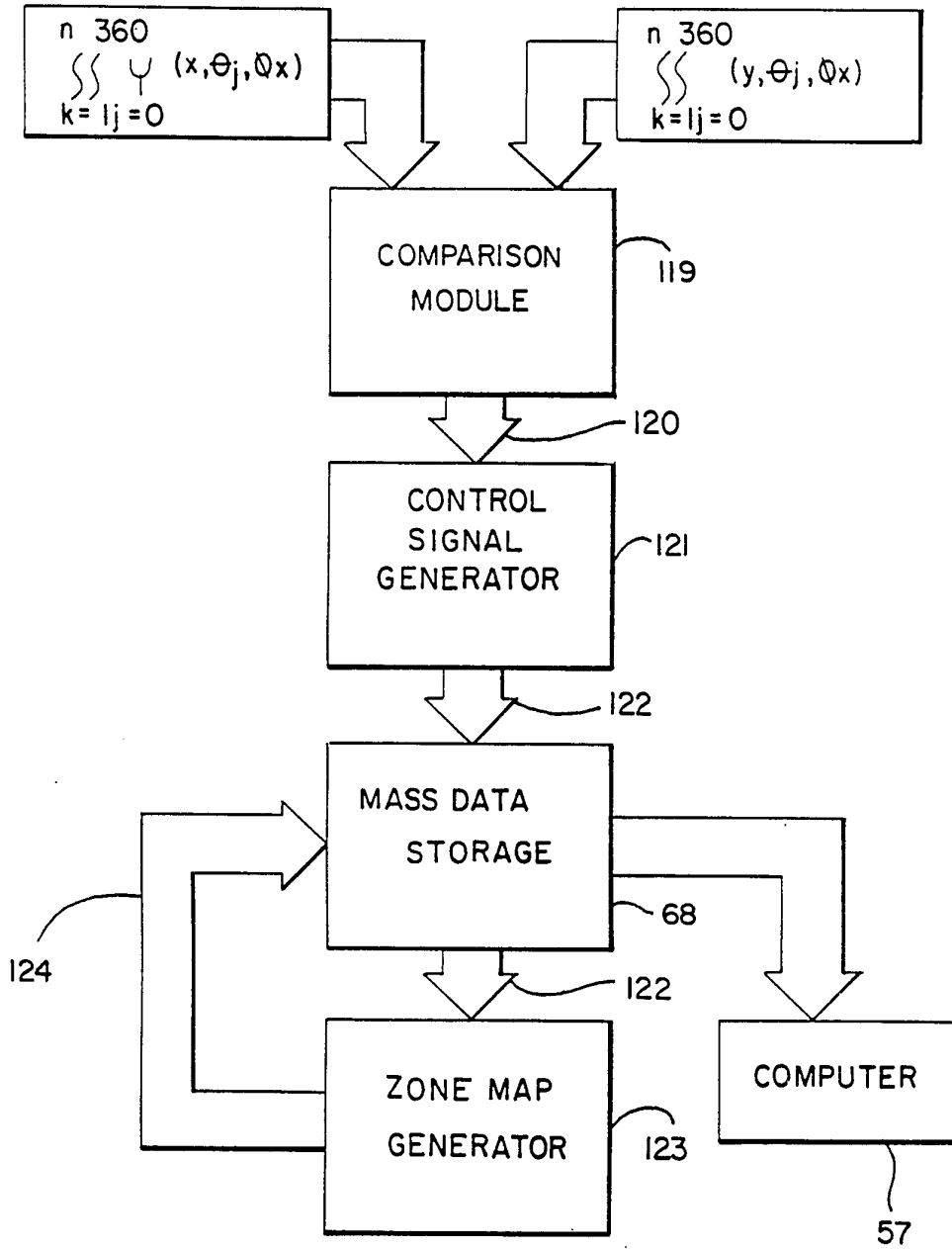

FIG.22

FIG. 23A

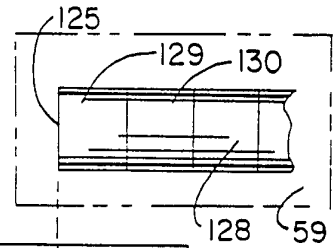
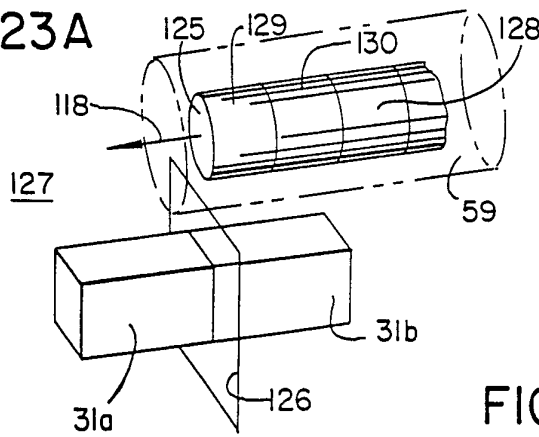

FIG. 23D

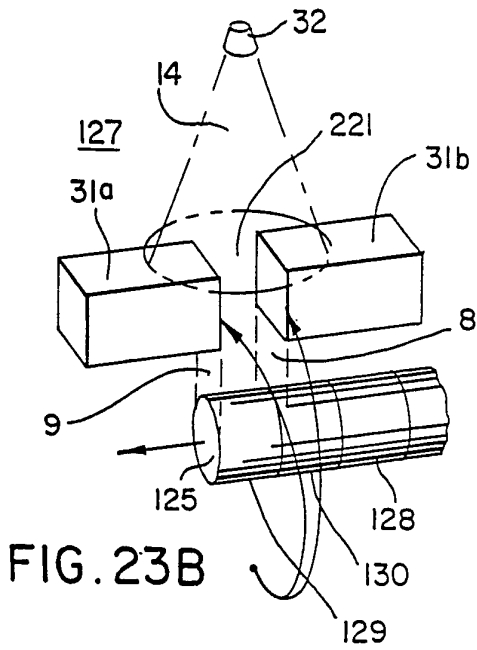

FIG. 23B

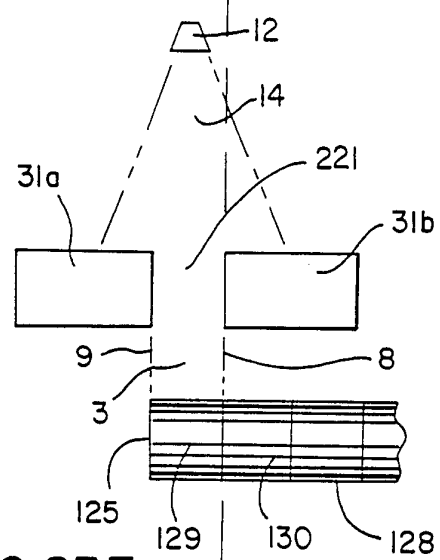

FIG. 23E

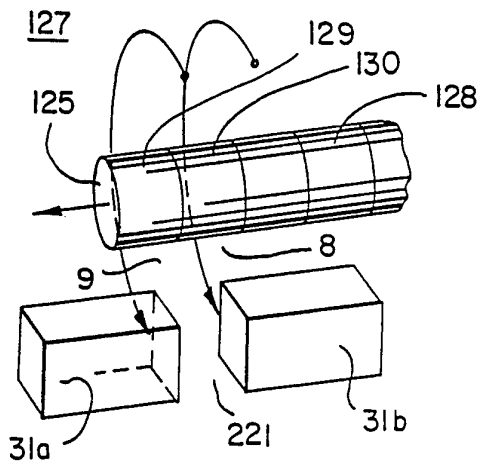

FIG. 23C

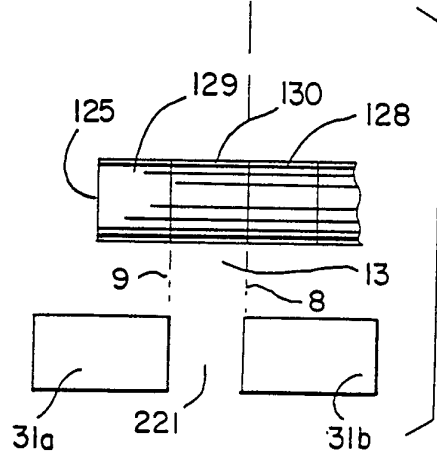

FIG. 23F



FIG. 24A

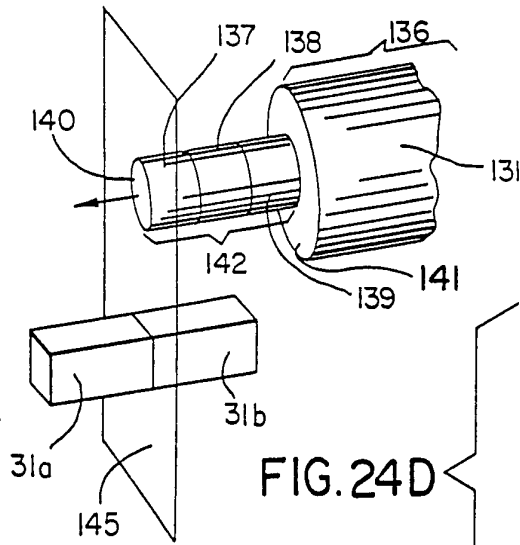

FIG. 24D

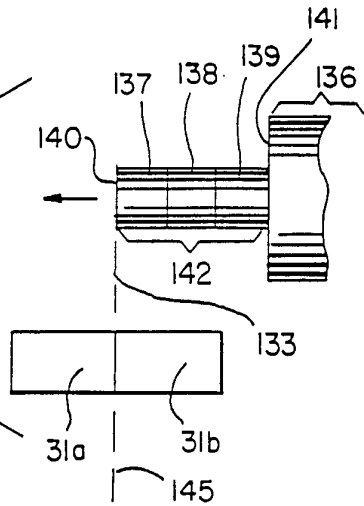

FIG. 24B

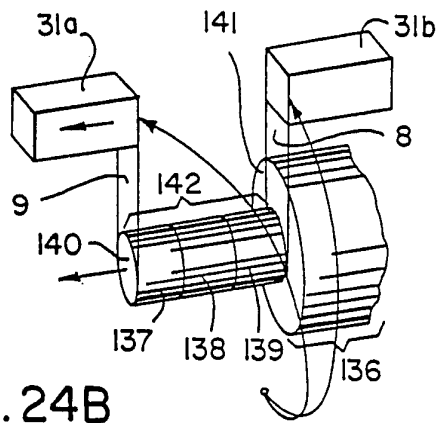

FIG. 24E

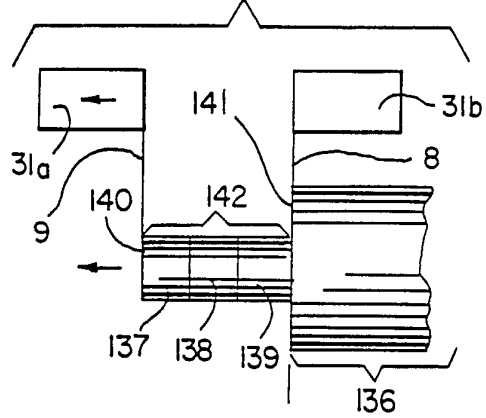

FIG. 24C

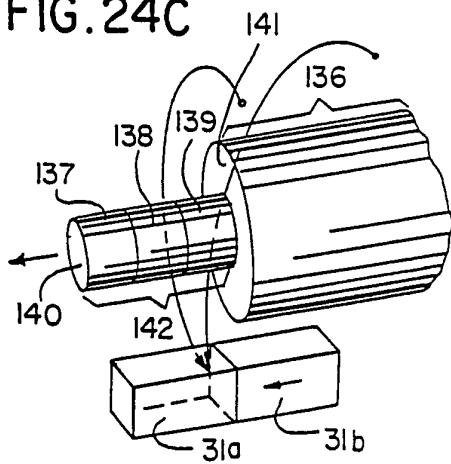

FIG. 24F

