

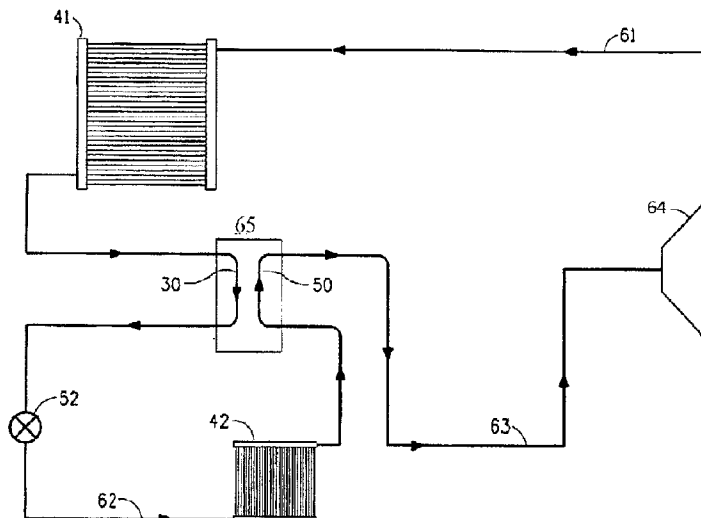

(22) Date de dépôt/Filing Date: 2008/05/09
(41) Mise à la disp. pub./Open to Public Insp.: 2008/11/20
(45) Date de délivrance/Issue Date: 2020/04/07
(62) Demande originale/Original Application: 2 944 695
(30) Priorités/Priorities: 2007/05/11 (US60/928,826);
2007/11/16 (US60/988,562);
2007/12/17 (US PCT/US2007/025675)

(51) Cl.Int./Int.Cl. *F25B 40/02* (2006.01),
F25B 39/02 (2006.01), *F28D 7/10* (2006.01)
(72) Inventeurs/Inventors:
CLODIC, DENIS, FR;
RIACHI, YOUSSEF, FR;
KOBAN, MARY, US
(73) Propriétaire/Owner:
THE CHEMOURS COMPANY FC, LLC, US
(74) Agent: TORYS LLP

(54) Titre : METHODE D'ECHANGE THERMIQUE DANS UN SYSTEME DE TRANSFERT THERMIQUE PAR COMPRESSION DE VAPEUR ET UN SYSTEME DE TRANSFERT THERMIQUE PAR COMPRESSION DE VAPEUR COMPORTANT UN ECHANGEUR THERMIQUE INTERMEDIAIRE DOTE D'UN EVAPORATEUR OU D'UN CONDENSEUR A DOUBLE RANGEE
(54) Title: VAPOR COMPRESSION HEAT TRANSFER SYSTEM COMPRISING AN INTERMEDIATE HEAT EXCHANGER AND A DUAL-ROW EVAPORATOR



(57) **Abrégé/Abstract:**

The present disclosure relates to a method for exchanging heat in a vapor compression heat transfer system. In particular, it relates to use of an intermediate heat exchanger to improve performance of a vapor compression heat transfer system utilizing a working fluid comprising at least one fluoroolefin. In addition, the present disclosure relates to a vapor compression heat transfer system comprising an intermediate heat exchanger in combination with a dual-row evaporator or a dual-row condenser, or both.

ABSTRACT

The present disclosure relates to a method for exchanging heat in a vapor compression heat transfer system. In particular, it relates to use of an intermediate heat exchanger to improve performance of a vapor compression heat transfer system utilizing a working fluid comprising at least one fluoroolefin. In addition, the present disclosure relates to a vapor compression heat transfer system comprising an intermediate heat exchanger in combination with a dual-row evaporator or a dual-row condenser, or both.

TITLE OF INVENTION

VAPOR COMPRESSION HEAT TRANSFER SYSTEM
COMPRISING AN INTERMEDIATE HEAT EXCHANGER AND
5 A DUAL-ROW EVAPORATOR

BACKGROUND OF THE INVENTION

1. **Field of the Invention.**

10 The present disclosure relates to a method for exchanging heat in a vapor compression heat transfer system. In particular, it relates to use of an intermediate heat exchanger to improve performance of a vapor compression heat transfer system utilizing a working fluid comprising at least one fluoroolefin.

15 2. **Description of Related Art.**

Methods for improving the performance of heat transfer systems, such as refrigeration systems and air conditioners, are always being sought, in order to reduce cost of operation of such systems.

20 When new working fluids for heat transfer systems, including vapor compression heat transfer systems, are being proposed it is important to be able to provide means of improving cooling capacity and energy efficiency for the new working fluids.

SUMMARY OF THE INVENTION

25 Applicants have found that the use of an internal heat exchanger in a vapor compression heat transfer system that uses a fluoroolefin provides unexpected benefits due to sub-cooling of the working fluid exiting out of the condenser. By "subcooling" is meant the reduction of the temperature of a liquid below that liquid's saturation point for a given pressure. The
30 saturation point is the temperature at which the vapor usually would condense to a liquid, but subcooling produces a lower temperature vapor at the given pressure. By cooling a vapor below the saturation point, the

net refrigeration capacity can be increased. Sub-cooling thereby improves cooling capacity and energy efficiency of a system, such as vapor compression heat transfer systems, which use fluoroolefins as their working fluid.

5 In particular, when the fluoroolefin 2,3,3,3-tetrafluoropropene (HFC-1234yf) is used as the working fluid, surprising results have been achieved with respect to coefficient of performance and capacity of the working fluid, as compared to the use of known working fluids such as 1,1,1,2-tetrafluoroethane (HFC-134a). In fact, the coefficient of
10 performance, as well as the cooling capacity of a system which uses HFC-1234yf has been increased by at least 7.5% as compared to a system which uses HFC-134a as the working fluid.

Therefore, in accordance with the present invention, the present disclosure provides a method of exchanging heat in a vapor compression
15 heat transfer system, comprising:

(a) circulating a working fluid comprising a fluoroolefin to an inlet of a first tube of an internal heat exchanger, through the internal heat exchanger and to an outlet thereof;

(b) circulating the working fluid from the outlet of the first tube of the
20 internal heat exchanger to an inlet of an evaporator, through the evaporator to evaporate the working fluid, thereby converting the working fluid into a gaseous working fluid, and through an outlet of the evaporator;

(c) circulating the working fluid from the outlet of the evaporator to an inlet of a second tube of the internal heat exchanger to transfer heat from the
25 liquid working fluid from the condenser to the gaseous working fluid from the evaporator, through the internal heat exchanger, and to an outlet of the second tube;

(d) circulating the working fluid from the outlet of the second tube of the internal heat exchanger to an inlet of a compressor, through the
30 compressor to compress the gaseous working fluid, and to an outlet of the compressor;

(e) circulating the working fluid from the outlet of the compressor to an inlet of a condenser and through the condenser to condense the compressed gaseous working fluid into a liquid, and to an outlet of the condenser;

5 (f) circulating the working fluid from the outlet of the condenser to an inlet of the first tube of the intermediate heat exchanger to transfer heat from the liquid from the condenser to the gas from the evaporator, and to an outlet of the second tube; and

(g) circulating the working fluid from the outlet of the second tube of
10 the internal heat exchanger back to the evaporator.

In addition, sub-cooling has been found to enhance the performance and efficiency of systems which use cross-current/counter-current heat exchange, such as those which employ either a dual-row condenser or a dual-row evaporator.

15 Therefore, further in accordance with the method of the present invention, the present disclosure also provides that the condensing step may comprise:

(i) circulating the working fluid to a back row of the dual-row condenser, where the back row receives the working fluid at a
20 first temperature; and

(ii) circulating the working fluid to a front row of the dual-row condenser, where the front row receives the working fluid at a second temperature, where the second temperature is less than the first temperature, so that air which travels across the
25 front row and the back row is preheated, whereby the temperature of the air is greater when it reaches the back row than when it reaches the front row.

In one embodiment, the working fluid of the present invention may be 2,3,3,3-tetrafluoropropene (HFC-1234yf).

30 Further in accordance with the method of the present invention, the present disclosure also provides that the evaporating step may comprise:

- 5
- (i) passing the working fluid through an inlet of a dual-row evaporator having a first row and a second row,
 - (ii) circulating the working fluid in a first row in a direction perpendicular to the flow of fluid through the inlet of the evaporator, and
 - (iii) circulating the working fluid in a second row in a direction generally counter to the direction of the flow of the working fluid through the inlet.

10 Also in accordance with the present invention, there is provided a vapor compression heat transfer system for exchanging heat comprising an intermediate heat exchanger in combination with a dual-row condenser or a dual-row evaporator, or both.

BRIEF DESCRIPTION OF THE DRAWINGS

15 The present invention may be better understood with reference to the following figures, wherein:

FIG. 1 is a schematic diagram of one embodiment of a vapor compression heat transfer system including an intermediate heat exchanger, used to practice the method of exchanging heat in a vapor compression heat transfer system according to the present invention.

20 FIG. 1A is a cross-sectional view of a particular embodiment of an intermediate heat exchanger where the tubes of the heat exchanger are concentric with each other.

FIG. 2 is a perspective view of a dual-row condenser which can be used with the vapor compression heat transfer system of FIG. 1.

25 FIG. 3 is a perspective view of a dual-row evaporator used which can be used with the vapor compression heat transfer system of FIG. 1.

DETAILED DESCRIPTION OF THE INVENTION

30 One embodiment of the present disclosure provides a method of exchanging heat in a vapor compression heat transfer system. A vapor-compression heat transfer system is a closed loop system which re-uses

working fluid in multiple steps producing a cooling effect in one step and a heating effect in a different step. Such a system generally includes an evaporator, a compressor, a condenser and an expansion device, and is known in the art. Reference will be made to Fig. 1 in describing this method.

5
10
15
20
25
30
35
40
45
50
55
60
65
70
75
80
85
90
95
100
105
110
115
120
125
130
135
140
145
150
155
160
165
170
175
180
185
190
195
200
205
210
215
220
225
230
235
240
245
250
255
260
265
270
275
280
285
290
295
300
305
310
315
320
325
330
335
340
345
350
355
360
365
370
375
380
385
390
395
400
405
410
415
420
425
430
435
440
445
450
455
460
465
470
475
480
485
490
495
500

With reference to Fig. 1, liquid working fluid from a condenser 41 flows through a line to an intermediate heat exchanger, or simply IHX 65. The intermediate heat exchanger includes a first tube 30, which contains a relatively hot liquid working fluid, and a second tube 50, which contains a relatively colder gaseous working fluid. The first tube of the IHX 65 is connected to the outlet line of the condenser. The liquid working fluid then flows through an expansion device 52 and through a line 62 to an evaporator 42, which is located in the vicinity of a body to cooled. In the evaporator, the working fluid is evaporated, which converts it into a gaseous working fluid, and the vaporization of the working fluid provides cooling. The expansion device 52 may be an expansion valve, a capillary tube, an orifice tube or any other device where the working fluid may undergo an abrupt reduction in pressure. The evaporator has an outlet, through which the cold gaseous working fluid flows to the second tube 50 of the IHX 65, wherein the cold gaseous working fluid comes in thermal contact with the hot liquid working fluid in the first tube 30 of the IHX 65, and thus the cold gaseous working fluid is warmed somewhat. The gaseous working fluid flows from the second tube of the IHX 65 through a line 63 to the inlet of a compressor 64. The gas is compressed in the compressor, and the compressed gaseous working fluid is discharged from the compressor and flows to the condenser 41 through a line 61 wherein the working fluid is condensed, thus giving off heat, and the cycle then repeats.

In an intermediate heat exchanger, the first tube containing the relatively hotter liquid working fluid and the second tube containing the relatively colder gaseous working fluid are in thermal contact, thus allowing transfer of heat from the hot liquid to the cold gas. The means by which the two tubes are in thermal contact may vary. In one embodiment,

the first tube has a larger diameter than the second tube, and the second tube is disposed concentrically in the first tube, and a hot liquid in the first tube surrounds a cold gas in the second tube. This embodiment is shown in FIG. 1A, where the first tube (30a) surrounds the second tube (50a).

5 Also, in one embodiment, the working fluid in the second tube of the internal heat exchanger may flow in a countercurrent direction to the direction of flow of the working fluid in the first tube, thereby cooling the working fluid in the first tube and heating the working fluid in the second tube.

10 Cross-current/counter-current heat exchange may be provided in the system of Fig. 1 by a dual-row condenser or a dual-row evaporator, although it should be noted that this system is not limited to such a dual-row condensers or evaporators. Such condensers and evaporators are described in detail in U.S. Provisional Patent Application No. 60/875,982,
15 filed December 19, 2006 (now International Application PCT/US07/25675, filed December 17, 2007), and may be designed particularly for working fluids that comprise non-azeotropic or near-azeotropic compositions. Therefore, in accordance with the present invention, there is provided a vapor compression heat transfer system which comprises either a dual-
20 row condenser, or a dual-row evaporator, or both. Such a system is the same as that described above with respect to FIG. 1, except for the description of the dual-row condenser or the dual-row evaporator.

Reference will be made to FIG. 2 to describe such a system which includes a dual-row condenser. A dual-row condenser is shown at 41 in
25 FIG. 2. In this dual-row cross-current/counter-current design, a hot working fluid enters the condenser through a first, or back, row 14, passes through the first row, and exits the condenser through a second, or front, row 13. The first row is connected to an inlet, or collector, 6, so that the working fluid enters first row 14 via collector, 6. The first row comprises a
30 first inlet manifold and a plurality of channels, or passes, one of which is shown at 2 in Fig. 2. The working fluid enters the inlet and flows inside first pass 2 of the first row. The channels allow the working fluid at a first

temperature to flow into the manifold and then through the channels in at least one direction and collect in a second outlet manifold, which is shown at 15 in Fig. 2. In the first, or back, row the working fluid is cooled in a counter current manner by air, which has been heated by the second, or front row 13 of this dual-row condenser. The working fluid flows from first pass 2 of the first row 14, to a second row, 13 which is connected to the first row. The second row comprises a plurality of channels for conducting the working fluid at a second temperature less than the working in the first row. The working fluid flows from first pass 2 of the first row to a pass 3 of the second by a conduit, or connection 7 and by a conduit 16. The working fluid then flows from pass 3 to a pass 4 in second row 13 through a conduit, or connection 8, which connects the first and second rows. The working fluid then flows from pass 4 to a pass 5 through a conduit, or connection 9. Then the sub-cooled working fluid exits the condenser through outlet manifold 15 by a connection, or outlet, 10. Air is circulated in a counter-current manner relative to the working fluid flow, as indicated by the arrow having points 11 and 12 of FIG. 2. The design shown in FIG. 2 is generic and can be used for any air-to-refrigerant condenser in stationary applications as well as in mobile applications.

Reference will now be made to FIG. 3 in describing a vapor compression heat transfer system comprising a dual-row evaporator. A dual-row evaporator is shown at 42 in FIG. 3. In this dual-row cross-current/counter-current design, the dual-row evaporator includes an inlet, a first, or front, row 17 connected to the inlet, a second second, or back row 18, connected to the first row, and an outlet connected to the back row. In particular, the working fluid enters the evaporator 19 at the lowest temperature through an inlet, or collector, 24 as shown in FIG. 3. Then the working fluid flows downwards through a tank 20 to a tank 21 through a collector 25, then from tank 21 to a tank 22 in the back row through a collector 26. The working fluid then flows from tank 22 to a tank 23 through a collector 27, and finally exits the evaporator through an outlet, or

collector, 28. Air is circulated in a cross-countercurrent arrangement as indicated by the arrow having points 29 and 30, of FIG. 3.

In the embodiments as shown in FIGS. 1, 1A, 2 and 3, the connecting lines between the components of the vapor compression heat transfer system, through which the working fluid may flow, may be constructed of any typical conduit material known for such purpose. In one embodiment, metal piping or metal tubing (such as aluminum or copper or copper alloy tubing) may be used to connect the components of the heat transfer system. In another embodiment, hoses, constructed of various materials, such as polymers or elastomers, or combinations of such materials with reinforcing materials such as metal mesh etc, may be used in the system. One example of a hose design for heat transfer systems, in particular for automobile air conditioning systems, is provided in U.S. Provisional Patent Application No. 60/841,713, filed September 1, 2006 (now International Application PCT/US07/019205 filed August 31, 2007 and published as WO2008-027255A1 on March 6, 2008). For the tubes of the IHX, metal piping or tubing provides more efficient transfer of heat from the hot liquid working fluid to the cold gaseous working fluid.

Various types of compressors may be used in the vapor compression heat transfer system of the embodiments of the present invention, including reciprocating, rotary, jet, centrifugal, scroll, screw or axial-flow, depending on the mechanical means to compress the fluid, or as positive-displacement (e.g., reciprocating, scroll or screw) or dynamic (e.g., centrifugal or jet).

In certain embodiments the heat transfer systems as disclosed herein may employ fin and tube heat exchangers, microchannel heat exchangers and vertical or horizontal single pass tube or plate type heat exchangers, among others for both the evaporator and condenser.

The closed loop vapor compression heat transfer system as described herein may be used in stationary refrigeration, air-conditioning, and heat pumps or mobile air-conditioning and refrigeration systems. Stationary air-conditioning and heat pump applications include window,

ductless, ducted, packaged terminal, chillers and light commercial and commercial air-conditioning systems, including packaged rooftop.

Refrigeration applications include domestic or home refrigerators and freezers, ice machines, self-contained coolers and freezers, walk-in
5 coolers and freezers and supermarket systems, and transport refrigeration systems.

Mobile refrigeration or mobile air-conditioning systems refer to any refrigeration or air-conditioning system incorporated into a transportation unit for the road, rail, sea or air. In addition, apparatus, which are meant
10 to provide refrigeration or air-conditioning for a system independent of any moving carrier, known as "intermodal" systems, are included in the present invention. Such intermodal systems include "containers" (combined sea/land transport) as well as "swap bodies" (combined road and rail transport). The present invention is particularly useful for road transport
15 refrigerating or air-conditioning apparatus, such as automobile air-conditioning apparatus or refrigerated road transport equipment.

The working fluid utilized in the vapor compression heat transfer system comprises at least one fluoroolefin. By fluoroolefin is meant any compound containing carbon, fluorine and optionally, hydrogen or oxygen
20 that also contains at least one double bond. These fluoroolefins may be linear, branched or cyclic.

Fluoroolefins have a variety of utilities in working fluids, which include use as foaming agents, blowing agents, fire extinguishing agents, heat transfer mediums (such as heat transfer fluids and refrigerants for
25 use in refrigeration systems, refrigerators, air-conditioning systems, heat pumps, chillers, and the like), to name a few.

In some embodiments, heat transfer compositions may comprise fluoroolefins comprising at least one compound with 2 to 12 carbon atoms, in another embodiment the fluoroolefins comprise compounds with 3 to 10
30 carbon atoms, and in yet another embodiment the fluoroolefins comprise compounds with 3 to 7 carbon atoms. Representative fluoroolefins include

but are not limited to all compounds as listed in Table 1, Table 2, and Table 3.

In one embodiment, the present methods use working fluids comprising fluoroolefins having the formula *E*- or *Z*-R¹CH=CHR² (Formula I), wherein R¹ and R² are, independently, C₁ to C₆ perfluoroalkyl groups. Examples of R¹ and R² groups include, but are not limited to, CF₃, C₂F₅, CF₂CF₂CF₃, CF(CF₃)₂, CF₂CF₂CF₂CF₃, CF(CF₃)CF₂CF₃, CF₂CF(CF₃)₂, C(CF₃)₃, CF₂CF₂CF₂CF₂CF₃, CF₂CF₂CF(CF₃)₂, C(CF₃)₂C₂F₅, CF₂CF₂CF₂CF₂CF₂CF₃, CF(CF₃)CF₂CF₂C₂F₅, and C(CF₃)₂CF₂C₂F₅. In one embodiment the fluoroolefins of Formula I, have at least about 4 carbon atoms in the molecule. In another embodiment, the fluoroolefins of Formula I have at least about 5 carbon atoms in the molecule. Exemplary, non-limiting Formula I compounds are presented in Table 1.

15

TABLE 1

Code	Structure	Chemical Name
F11E	$\text{CF}_3\text{CH}=\text{CHCF}_3$	1,1,1,4,4,4-hexafluorobut-2-ene
F12E	$\text{CF}_3\text{CH}=\text{CHC}_2\text{F}_5$	1,1,1,4,4,5,5,5-octafluoropent-2-ene
F13E	$\text{CF}_3\text{CH}=\text{CHCF}_2\text{C}_2\text{F}_5$	1,1,1,4,4,5,5,6,6,6-decafluorohex-2-ene
F13iE	$\text{CF}_3\text{CH}=\text{CHCF}(\text{CF}_3)_2$	1,1,1,4,5,5,5-heptafluoro-4-(trifluoromethyl)pent-2-ene
F22E	$\text{C}_2\text{F}_5\text{CH}=\text{CHC}_2\text{F}_5$	1,1,1,2,2,5,5,6,6,6-decafluorohex-3-ene
F14E	$\text{CF}_3\text{CH}=\text{CH}(\text{CF}_2)_3\text{CF}_3$	1,1,1,4,4,5,5,6,6,7,7,7-dodecafluorohept-2-ene
F14iE	$\text{CF}_3\text{CH}=\text{CHCF}_2\text{CF}(\text{CF}_3)_2$	1,1,1,4,4,5,6,6,6-nonafluoro-5-(trifluoromethyl)hex-2-ene
F14sE	$\text{CF}_3\text{CH}=\text{CHCF}(\text{CF}_3)-\text{C}_2\text{F}_5$	1,1,1,4,5,5,6,6,6-nonafluoro-4-(trifluoromethyl)hex-2-ene
F14iE	$\text{CF}_3\text{CH}=\text{CHC}(\text{CF}_3)_3$	1,1,1,5,5,5-hexafluoro-4,4-bis(trifluoromethyl)pent-2-ene
F23E	$\text{C}_2\text{F}_5\text{CH}=\text{CHCF}_2\text{C}_2\text{F}_5$	1,1,1,2,2,5,5,6,6,7,7,7-dodecafluorohept-3-ene
F23iE	$\text{C}_2\text{F}_5\text{CH}=\text{CHCF}(\text{CF}_3)_2$	1,1,1,2,2,5,6,6,6-nonafluoro-5-(trifluoromethyl)hex-3-ene
F15E	$\text{CF}_3\text{CH}=\text{CH}(\text{CF}_2)_4\text{CF}_3$	1,1,1,4,4,5,5,6,6,7,7,8,8,8-tetradecafluorooct-2-ene
F15iE	$\text{CF}_3\text{CH}=\text{CH}-\text{CF}_2\text{CF}_2\text{CF}(\text{CF}_3)_2$	1,1,1,4,4,5,5,6,6,7,7,7-undecafluoro-6-(trifluoromethyl)hept-2-ene
F15iE	$\text{CF}_3\text{CH}=\text{CH}-\text{C}(\text{CF}_3)_2\text{C}_2\text{F}_5$	1,1,1,5,5,6,6,6-octafluoro-4,4-bis(trifluoromethyl)hex-2-ene
F24E	$\text{C}_2\text{F}_5\text{CH}=\text{CH}(\text{CF}_2)_3\text{CF}_3$	1,1,1,2,2,5,5,6,6,7,7,8,8,8-tetradecafluorooct-3-ene
F24iE	$\text{C}_2\text{F}_5\text{CH}=\text{CHCF}_2\text{CF}(\text{CF}_3)_2$	1,1,1,2,2,5,5,6,6,7,7,7-undecafluoro-6-(trifluoromethyl)hept-3-ene
F24sE	$\text{C}_2\text{F}_5\text{CH}=\text{CHCF}(\text{CF}_3)-\text{C}_2\text{F}_5$	1,1,1,2,2,5,6,6,7,7,7-undecafluoro-5-(trifluoromethyl)hept-3-ene
F24iE	$\text{C}_2\text{F}_5\text{CH}=\text{CHC}(\text{CF}_3)_3$	1,1,1,2,2,6,6,6-octafluoro-5,5-bis(trifluoromethyl)hex-3-ene
F33E	$\text{C}_2\text{F}_5\text{CF}_2\text{CH}=\text{CH}-\text{CF}_2\text{C}_2\text{F}_5$	1,1,1,2,2,3,3,6,6,7,7,8,8,8-tetradecafluorooct-4-ene

F3i3iE	$(\text{CF}_3)_2\text{CFCH}=\text{CH}-\text{CF}(\text{CF}_3)_2$	1,1,1,2,5,6,6,6-octafluoro-2,5-bis(trifluoromethyl)hex-3-ene
F33iE	$\text{C}_2\text{F}_5\text{CF}_2\text{CH}=\text{CH}-\text{CF}(\text{CF}_3)_2$	1,1,1,2,5,5,6,6,7,7,7-undecafluoro-2-(trifluoromethyl)hept-3-ene
F16E	$\text{CF}_3\text{CH}=\text{CH}(\text{CF}_2)_5\text{CF}_3$	1,1,1,4,4,5,5,6,6,7,7,8,8,,9,9,9-hexadecafluoronon-2-ene
F16sE	$\text{CF}_3\text{CH}=\text{CHCF}(\text{CF}_3)(\text{CF}_2)_2\text{C}_2\text{F}_5$	1,1,1,4,5,5,6,6,7,7,8,8,8-tridecafluoro-4-(trifluoromethyl)hept-2-ene
F16iE	$\text{CF}_3\text{CH}=\text{CHC}(\text{CF}_3)_2\text{CF}_2\text{C}_2\text{F}_5$	1,1,1,6,6,6-octafluoro-4,4-bis(trifluoromethyl)hept-2-ene
F25E	$\text{C}_2\text{F}_5\text{CH}=\text{CH}(\text{CF}_2)_4\text{CF}_3$	1,1,1,2,2,5,5,6,6,7,7,8,8,9,9,9-hexadecafluoronon-3-ene
F25iE	$\text{C}_2\text{F}_5\text{CH}=\text{CH}-\text{CF}_2\text{CF}_2\text{CF}(\text{CF}_3)_2$	1,1,1,2,2,5,5,6,6,7,8,8,8-tridecafluoro-7-(trifluoromethyl)oct-3-ene
F25iE	$\text{C}_2\text{F}_5\text{CH}=\text{CH}-\text{C}(\text{CF}_3)_2\text{C}_2\text{F}_5$	1,1,1,2,2,6,6,7,7,7-decafluoro-5,5-bis(trifluoromethyl)hept-3-ene
F34E	$\text{C}_2\text{F}_5\text{CF}_2\text{CH}=\text{CH}-(\text{CF}_2)_3\text{CF}_3$	1,1,1,2,2,3,3,6,6,7,7,8,8,9,9,9-hexadecafluoronon-4-ene
F34iE	$\text{C}_2\text{F}_5\text{CF}_2\text{CH}=\text{CH}-\text{CF}_2\text{CF}(\text{CF}_3)_2$	1,1,1,2,2,3,3,6,6,7,8,8,8-tridecafluoro-7-(trifluoromethyl)oct-4-ene
F34sE	$\text{C}_2\text{F}_5\text{CF}_2\text{CH}=\text{CH}-\text{CF}(\text{CF}_3)\text{C}_2\text{F}_5$	1,1,1,2,2,3,3,6,7,7,8,8,8-tridecafluoro-6-(trifluoromethyl)oct-4-ene
F34tE	$\text{C}_2\text{F}_5\text{CF}_2\text{CH}=\text{CH}-\text{C}(\text{CF}_3)_3$	1,1,1,5,5,6,6,7,7,7-decafluoro-2,2-bis(trifluoromethyl)hept-3-ene
F3i4E	$(\text{CF}_3)_2\text{CFCH}=\text{CH}-(\text{CF}_2)_3\text{CF}_3$	1,1,1,2,5,5,6,6,7,7,8,8,8-tridecafluoro-2(trifluoromethyl)oct-3-ene
F3i4iE	$(\text{CF}_3)_2\text{CFCH}=\text{CH}-\text{CF}_2\text{CF}(\text{CF}_3)_2$	1,1,1,2,5,5,6,6,7,7,7-decafluoro-2,6-bis(trifluoromethyl)hept-3-ene
F3i4sE	$(\text{CF}_3)_2\text{CFCH}=\text{CH}-\text{CF}(\text{CF}_3)\text{C}_2\text{F}_5$	1,1,1,2,5,6,6,7,7,7-decafluoro-2,5-bis(trifluoromethyl)hept-3-ene
F3i4tE	$(\text{CF}_3)_2\text{CFCH}=\text{CH}-\text{C}(\text{CF}_3)_3$	1,1,1,2,6,6,6-heptafluoro-2,5,5-tris(trifluoromethyl)hex-3-ene

F26E	$C_2F_5CH=CH(CF_2)_5CF_3$	1,1,1,2,2,5,5,6,6,7,7,8,8,9,9,10,10,10-octadecafluorodec-3-ene
F26sE	$C_2F_5CH=CHCF(CF_3)(CF_2)_2C_2F_5$	1,1,1,2,2,5,6,6,7,7,8,8,9,9,9-pentadecafluoro-5-(trifluoromethyl)non-3-ene
F26tE	$C_2F_5CH=CHC(CF_3)_2CF_2C_2F_5$	1,1,1,2,2,6,6,7,7,8,8,8-dodecafluoro-5,5-bis(trifluoromethyl)oct-3-ene
F35E	$C_2F_5CF_2CH=CH-(CF_2)_4CF_3$	1,1,1,2,2,3,3,6,6,7,7,8,8,9,9,10,10,10-octadecafluorodec-4-ene
F35iE	$C_2F_5CF_2CH=CH-CF_2CF_2CF(CF_3)_2$	1,1,1,2,2,3,3,6,6,7,7,8,8,9,9,9-pentadecafluoro-8-(trifluoromethyl)non-4-ene
F35tE	$C_2F_5CF_2CH=CH-C(CF_3)_2C_2F_5$	1,1,1,2,2,3,3,7,7,8,8,8-dodecafluoro-6,6-bis(trifluoromethyl)oct-4-ene
F3i5E	$(CF_3)_2CFCH=CH-(CF_2)_4CF_3$	1,1,1,2,5,5,6,6,7,7,8,8,9,9,9-pentadecafluoro-2-(trifluoromethyl)non-3-ene
F3i5iE	$(CF_3)_2CFCH=CH-CF_2CF_2CF(CF_3)_2$	1,1,1,2,5,5,6,6,7,8,8,8-dodecafluoro-2,7-bis(trifluoromethyl)oct-3-ene
F3i5tE	$(CF_3)_2CFCH=CH-C(CF_3)_2C_2F_5$	1,1,1,2,6,6,7,7,7-nonafluoro-2,5,5-tris(trifluoromethyl)hept-3-ene
F44E	$CF_3(CF_2)_3CH=CH-(CF_2)_3CF_3$	1,1,1,2,2,3,3,4,4,7,7,8,8,9,9,10,10,10-octadecafluorodec-5-ene
F44iE	$CF_3(CF_2)_3CH=CH-CF_2CF(CF_3)_2$	1,1,1,2,3,3,6,6,7,7,8,8,9,9,9-pentadecafluoro-2-(trifluoromethyl)non-4-ene
F44sE	$CF_3(CF_2)_3CH=CH-CF(CF_3)C_2F_5$	1,1,1,2,2,3,6,6,7,7,8,8,9,9,9-pentadecafluoro-3-(trifluoromethyl)non-4-ene
F44tE	$CF_3(CF_2)_3CH=CH-C(CF_3)_3$	1,1,1,5,5,6,6,7,7,8,8,8-dodecafluoro-2,2,-bis(trifluoromethyl)oct-3-ene
F4i4iE	$(CF_3)_2CFCF_2CH=CH-CF_2CF(CF_3)_2$	1,1,1,2,3,3,6,6,7,8,8,8-dodecafluoro-2,7-bis(trifluoromethyl)oct-4-ene
F4i4sE	$(CF_3)_2CFCF_2CH=CH-CF(CF_3)C_2F_5$	1,1,1,2,3,3,6,7,7,8,8,8-dodecafluoro-2,6-bis(trifluoromethyl)oct-4-ene
F4i4tE	$(CF_3)_2CFCF_2CH=CH-C(CF_3)_3$	1,1,1,5,5,6,7,7,7-nonafluoro-2,2,6-tris(trifluoromethyl)hept-3-ene

F4s4sE	$C_2F_5CF(CF_3)CH=CH-CF(CF_3)C_2F_5$	1,1,1,2,2,3,6,7,7,8,8,8-dodecafluoro-3,6-bis(trifluoromethyl)oct-4-ene
F4s4tE	$C_2F_5CF(CF_3)CH=CH-C(CF_3)_3$	1,1,1,5,6,6,7,7,7-nonafluoro-2,2,5-tris(trifluoromethyl)hept-3-ene
F4t4tE	$(CF_3)_3CCH=CH-C(CF_3)_3$	1,1,1,6,6,6-hexafluoro-2,2,5,5-tetrakis(trifluoromethyl)hex-3-ene

Compounds of Formula I may be prepared by contacting a perfluoroalkyl iodide of the formula R^1I with a perfluoroalkyltrihydroolefin of the formula $R^2CH=CH_2$ to form a trihydroiodoperfluoroalkane of the formula $R^1CH_2CHIR^2$. This trihydroiodoperfluoroalkane can then be dehydroiodinated to form $R^1CH=CHR^2$. Alternatively, the olefin $R^1CH=CHR^2$ may be prepared by dehydroiodination of a trihydroiodoperfluoroalkane of the formula $R^1CHICH_2R^2$ formed in turn by reacting a perfluoroalkyl iodide of the formula R^2I with a perfluoroalkyltrihydroolefin of the formula $R^1CH=CH_2$.

The contacting of a perfluoroalkyl iodide with a perfluoroalkyltrihydroolefin may take place in batch mode by combining the reactants in a suitable reaction vessel capable of operating under the autogenous pressure of the reactants and products at reaction temperature. Suitable reaction vessels include fabricated from stainless steels, in particular of the austenitic type, and the well-known high nickel alloys such as Monel® nickel-copper alloys, Hastelloy® nickel based alloys and Inconel® nickel-chromium alloys.

Alternatively, the reaction may take be conducted in semi-batch mode in which the perfluoroalkyltrihydroolefin reactant is added to the perfluoroalkyl iodide reactant by means of a suitable addition apparatus such as a pump at the reaction temperature.

The ratio of perfluoroalkyl iodide to perfluoroalkyltrihydroolefin should be between about 1:1 to about 4:1, preferably from about 1.5:1 to 2.5:1. Ratios less than 1.5:1 tend to result in large amounts of the 2:1

adduct as reported by Jeanneaux, et. al. in Journal of Fluorine Chemistry, Vol. 4, pages 261-270 (1974).

Preferred temperatures for contacting of said perfluoroalkyl iodide with said perfluoroalkyltrihydroolefin are preferably within the range of
5 about 150°C to 300°C, preferably from about 170°C to about 250°C, and most preferably from about 180°C to about 230°C.

Suitable contact times for the reaction of the perfluoroalkyl iodide with the perfluoroalkyltrihydroolefin are from about 0.5 hour to 18 hours, preferably from about 4 to about 12 hours.

10 The trihydroiodoperfluoroalkane prepared by reaction of the perfluoroalkyl iodide with the perfluoroalkyltrihydroolefin may be used directly in the dehydroiodination step or may preferably be recovered and purified by distillation prior to the dehydroiodination step.

The dehydroiodination step is carried out by contacting the
15 trihydroiodoperfluoroalkane with a basic substance. Suitable basic substances include alkali metal hydroxides (e.g., sodium hydroxide or potassium hydroxide), alkali metal oxide (for example, sodium oxide), alkaline earth metal hydroxides (e.g., calcium hydroxide), alkaline earth metal oxides (e.g., calcium oxide), alkali metal alkoxides (e.g., sodium
20 methoxide or sodium ethoxide), aqueous ammonia, sodium amide, or mixtures of basic substances such as soda lime. Preferred basic substances are sodium hydroxide and potassium hydroxide.

The contacting of the trihydroiodoperfluoroalkane with a basic substance may take place in the liquid phase preferably in the presence of
25 a solvent capable of dissolving at least a portion of both reactants. Solvents suitable for the dehydroiodination step include one or more polar organic solvents such as alcohols (e.g., methanol, ethanol, n-propanol, isopropanol, n-butanol, isobutanol, and tertiary butanol), nitriles (e.g., acetonitrile, propionitrile, butyronitrile, benzonitrile, or adiponitrile),
30 dimethyl sulfoxide, N,N-dimethylformamide, N,N-dimethylacetamide, or sulfolane. The choice of solvent may depend on the boiling point product and the ease of separation of traces of the solvent from the product during

purification. Typically, ethanol or isopropanol are good solvents for the reaction.

Typically, the dehydroiodination reaction may be carried out by addition of one of the reactants (either the basic substance or the trihydroiodoperfluoroalkane) to the other reactant in a suitable reaction vessel. The reaction may be fabricated from glass, ceramic, or metal and is preferably agitated with an impeller or stirring mechanism.

Temperatures suitable for the dehydroiodination reaction are from about 10°C to about 100°C, preferably from about 20°C to about 70°C. The dehydroiodination reaction may be carried out at ambient pressure or at reduced or elevated pressure. Of note are dehydroiodination reactions in which the compound of Formula I is distilled out of the reaction vessel as it is formed.

Alternatively, the dehydroiodination reaction may be conducted by contacting an aqueous solution of said basic substance with a solution of the trihydroiodoperfluoroalkane in one or more organic solvents of lower polarity such as an alkane (e.g., hexane, heptane, or octane), aromatic hydrocarbon (e.g., toluene), halogenated hydrocarbon (e.g., methylene chloride, chloroform, carbon tetrachloride, or perchloroethylene), or ether (e.g., diethyl ether, methyl tert-butyl ether, tetrahydrofuran, 2-methyl tetrahydrofuran, dioxane, dimethoxyethane, diglyme, or tetraglyme) in the presence of a phase transfer catalyst. Suitable phase transfer catalysts include quaternary ammonium halides (e.g., tetrabutylammonium bromide, tetrabutylammonium hydrosulfate, triethylbenzylammonium chloride, dodecyltrimethylammonium chloride, and tricapyrylmethylammonium chloride), quaternary phosphonium halides (e.g., triphenylmethylphosphonium bromide and tetraphenylphosphonium chloride), or cyclic polyether compounds known in the art as crown ethers (e.g., 18-crown-6 and 15-crown-5).

Alternatively, the dehydroiodination reaction may be conducted in the absence of solvent by adding the trihydroiodoperfluoroalkane to a solid or liquid basic substance.

Suitable reaction times for the dehydroiodination reactions are from about 15 minutes to about six hours or more depending on the solubility of the reactants. Typically the dehydroiodination reaction is rapid and requires about 30 minutes to about three hours for completion.

- 5 The compound of formula I may be recovered from the dehydroiodination reaction mixture by phase separation after addition of water, by distillation, or by a combination thereof.

In another embodiment of the present invention, fluoroolefins comprise cyclic fluoroolefins (cyclo-[CX=CY(CZW)_n]) (Formula II), wherein
 10 X, Y, Z, and W are independently selected from H and F, and n is an integer from 2 to 5). In one embodiment the fluoroolefins of Formula II, have at least about 3 carbon atoms in the molecule. In another embodiment, the fluoroolefins of Formula II have at least about 4 carbon atoms in the molecule. In yet another embodiment, the fluoroolefins of
 15 Formula II have at least about 5 carbon atoms in the molecule. Representative cyclic fluoroolefins of Formula II are listed in Table 2.

TABLE 2

Cyclic fluoroolefins	Structure	Chemical name
FC-C1316cc	cyclo-CF ₂ CF ₂ CF=CF-	1,2,3,3,4,4-hexafluorocyclobutene
HFC-C1334cc	cyclo-CF ₂ CF ₂ CH=CH-	3,3,4,4-tetrafluorocyclobutene
HFC-C1436	cyclo-CF ₂ CF ₂ CF ₂ CH=CH-	3,3,4,4,5,5-hexafluorocyclopentene
FC-C1418y	cyclo-CF ₂ CF=CFCF ₂ CF ₂ -	1,2,3,3,4,4,5,5-octafluorocyclopentene
FC-C151-10y	cyclo-CF ₂ CF=CFCF ₂ CF ₂ CF ₂ -	1,2,3,3,4,4,5,5,6,6-decafluorocyclohexene

- 20 The compositions of the present invention may comprise a single compound of Formula I or formula II, for example, one of the compounds in Table 1 or Table 2, or may comprise a combination of compounds of Formula I or formula II.

- In another embodiment, fluoroolefins may comprise those
 25 compounds listed in Table 3.

TABLE 3

Name	Structure	Chemical name
HFC-1225ye	$\text{CF}_3\text{CF}=\text{CHF}$	1,2,3,3,3-pentafluoro-1-propene
HFC-1225zc	$\text{CF}_3\text{CH}=\text{CF}_2$	1,1,3,3,3-pentafluoro-1-propene
HFC-1225yc	$\text{CHF}_2\text{CF}=\text{CF}_2$	1,1,2,3,3-pentafluoro-1-propene
HFC-1234ye	$\text{CHF}_2\text{CF}=\text{CHF}$	1,2,3,3-tetrafluoro-1-propene
HFC-1234yf	$\text{CF}_3\text{CF}=\text{CH}_2$	2,3,3,3-tetrafluoro-1-propene
HFC-1234ze	$\text{CF}_3\text{CH}=\text{CHF}$	1,3,3,3-tetrafluoro-1-propene
HFC-1234yc	$\text{CH}_2\text{FCF}=\text{CF}_2$	1,1,2,3-tetrafluoro-1-propene
HFC-1234zc	$\text{CHF}_2\text{CH}=\text{CF}_2$	1,1,3,3-tetrafluoro-1-propene
HFC-1243yf	$\text{CHF}_2\text{CF}=\text{CH}_2$	2,3,3-trifluoro-1-propene
HFC-1243zf	$\text{CF}_3\text{CH}=\text{CH}_2$	3,3,3-trifluoro-1-propene
HFC-1243yc	$\text{CH}_3\text{CF}=\text{CF}_2$	1,1,2-trifluoro-1-propene
HFC-1243zc	$\text{CH}_2\text{FCH}=\text{CF}_2$	1,1,3-trifluoro-1-propene
HFC-1243ye	$\text{CH}_2\text{FCF}=\text{CHF}$	1,2,3-trifluoro-1-propene
HFC-1243ze	$\text{CHF}_2\text{CH}=\text{CHF}$	1,3,3-trifluoro-1-propene
FC-1318my	$\text{CF}_3\text{CF}=\text{CFCF}_3$	1,1,1,2,3,4,4,4-octafluoro-2-butene
FC-1318cy	$\text{CF}_3\text{CF}_2\text{CF}=\text{CF}_2$	1,1,2,3,3,4,4,4-octafluoro-1-butene
HFC-1327my	$\text{CF}_3\text{CF}=\text{CHCF}_3$	1,1,1,2,4,4,4-heptafluoro-2-butene
HFC-1327ye	$\text{CHF}=\text{CFCF}_2\text{CF}_3$	1,2,3,3,4,4,4-heptafluoro-1-butene
HFC-1327py	$\text{CHF}_2\text{CF}=\text{CFCF}_3$	1,1,1,2,3,4,4-heptafluoro-2-butene
HFC-1327et	$(\text{CF}_3)_2\text{C}=\text{CHF}$	1,3,3,3-tetrafluoro-2-(trifluoromethyl)-1-propene
HFC-1327cz	$\text{CF}_2=\text{CHCF}_2\text{CF}_3$	1,1,3,3,4,4,4-heptafluoro-1-butene
HFC-1327cye	$\text{CF}_2=\text{CFCHFCF}_3$	1,1,2,3,4,4,4-heptafluoro-1-butene
HFC-1327cyc	$\text{CF}_2=\text{CFCF}_2\text{CHF}_2$	1,1,2,3,3,4,4-heptafluoro-1-butene
HFC-1336yf	$\text{CF}_3\text{CF}_2\text{CF}=\text{CH}_2$	2,3,3,4,4,4-hexafluoro-1-butene
HFC-1336ze	$\text{CHF}=\text{CHCF}_2\text{CF}_3$	1,3,3,4,4,4-hexafluoro-1-butene
HFC-1336eye	$\text{CHF}=\text{CFCHFCF}_3$	1,2,3,4,4,4-hexafluoro-1-butene
HFC-1336eyc	$\text{CHF}=\text{CFCF}_2\text{CHF}_2$	1,2,3,3,4,4-hexafluoro-1-butene
HFC-1336pyy	$\text{CHF}_2\text{CF}=\text{CFCHF}_2$	1,1,2,3,4,4-hexafluoro-2-butene
HFC-1336qy	$\text{CH}_2\text{FCF}=\text{CFCF}_3$	1,1,1,2,3,4-hexafluoro-2-butene
HFC-1336pz	$\text{CHF}_2\text{CH}=\text{CFCF}_3$	1,1,1,2,4,4-hexafluoro-2-butene
HFC-1336mzy	$\text{CF}_3\text{CH}=\text{CFCHF}_2$	1,1,1,3,4,4-hexafluoro-2-butene
HFC-1336qc	$\text{CF}_2=\text{CFCF}_2\text{CH}_2\text{F}$	1,1,2,3,3,4-hexafluoro-1-butene
HFC-1336pe	$\text{CF}_2=\text{CFCHFCF}_2$	1,1,2,3,4,4-hexafluoro-1-butene
HFC-1336ft	$\text{CH}_2=\text{C}(\text{CF}_3)_2$	3,3,3-trifluoro-2-(trifluoromethyl)-1-propene

HFC-1345qz	$\text{CH}_2\text{FCH}=\text{CFCF}_3$	1,1,1,2,4-pentafluoro-2-butene
HFC-1345mzy	$\text{CF}_3\text{CH}=\text{CFCH}_2\text{F}$	1,1,1,3,4-pentafluoro-2-butene
HFC-1345fz	$\text{CF}_3\text{CF}_2\text{CH}=\text{CH}_2$	3,3,4,4,4-pentafluoro-1-butene
HFC-1345mzz	$\text{CHF}_2\text{CH}=\text{CHCF}_3$	1,1,1,4,4-pentafluoro-2-butene
HFC-1345sy	$\text{CH}_3\text{CF}=\text{CFCF}_3$	1,1,1,2,3-pentafluoro-2-butene
HFC-1345fyc	$\text{CH}_2=\text{CFCF}_2\text{CHF}_2$	2,3,3,4,4-pentafluoro-1-butene
HFC-1345pyz	$\text{CHF}_2\text{CF}=\text{CHCHF}_2$	1,1,2,4,4-pentafluoro-2-butene
HFC-1345cyc	$\text{CH}_3\text{CF}_2\text{CF}=\text{CF}_2$	1,1,2,3,3-pentafluoro-1-butene
HFC-1345pyy	$\text{CH}_2\text{FCF}=\text{CFCHF}_2$	1,1,2,3,4-pentafluoro-2-butene
HFC-1345eyc	$\text{CH}_2\text{FCF}_2\text{CF}=\text{CHF}$	1,2,3,3,4-pentafluoro-1-butene
HFC-1345ctm	$\text{CF}_2=\text{C}(\text{CF}_3)(\text{CH}_3)$	1,1,3,3,3-pentafluoro-2-methyl-1-propene
HFC-1345ftp	$\text{CH}_2=\text{C}(\text{CHF}_2)(\text{CF}_3)$	2-(difluoromethyl)-3,3,3-trifluoro-1-propene
HFC-1345fye	$\text{CH}_2=\text{CFCHFCF}_3$	2,3,4,4,4-pentafluoro-1-butene
HFC-1345eyf	$\text{CHF}=\text{CFCH}_2\text{CF}_3$	1,2,4,4,4-pentafluoro-1-butene
HFC-1345eze	$\text{CHF}=\text{CHCHFCF}_3$	1,3,4,4,4-pentafluoro-1-butene
HFC-1345ezc	$\text{CHF}=\text{CHCF}_2\text{CHF}_2$	1,3,3,4,4-pentafluoro-1-butene
HFC-1345eye	$\text{CHF}=\text{CFCHFCHF}_2$	1,2,3,4,4-pentafluoro-1-butene
HFC-1354fzc	$\text{CH}_2=\text{CHCF}_2\text{CHF}_2$	3,3,4,4-tetrafluoro-1-butene
HFC-1354ctp	$\text{CF}_2=\text{C}(\text{CHF}_2)(\text{CH}_3)$	1,1,3,3-tetrafluoro-2-methyl-1-propene
HFC-1354etm	$\text{CHF}=\text{C}(\text{CF}_3)(\text{CH}_3)$	1,3,3,3-tetrafluoro-2-methyl-1-propene
HFC-1354lfp	$\text{CH}_2=\text{C}(\text{CHF}_2)_2$	2-(difluoromethyl)-3,3-difluoro-1-propene
HFC-1354my	$\text{CF}_3\text{CF}=\text{CHCH}_3$	1,1,1,2-tetrafluoro-2-butene
HFC-1354mzy	$\text{CH}_3\text{CF}=\text{CHCF}_3$	1,1,1,3-tetrafluoro-2-butene
FC-141-10myy	$\text{CF}_3\text{CF}=\text{CFCF}_2\text{CF}_3$	1,1,1,2,3,4,4,5,5,5-decafluoro-2-pentene
FC-141-10cy	$\text{CF}_2=\text{CFCF}_2\text{CF}_2\text{CF}_3$	1,1,2,3,3,4,4,5,5,5-decafluoro-1-pentene
HFC-1429mzt	$(\text{CF}_3)_2\text{C}=\text{CHCF}_3$	1,1,1,4,4,4-hexafluoro-2-(trifluoromethyl)-2-butene
HFC-1429myz	$\text{CF}_3\text{CF}=\text{CHCF}_2\text{CF}_3$	1,1,1,2,4,4,5,5,5-nonafluoro-2-pentene
HFC-1429mzy	$\text{CF}_3\text{CH}=\text{CFCF}_2\text{CF}_3$	1,1,1,3,4,4,5,5,5-nonafluoro-2-pentene
HFC-1429eyc	$\text{CHF}=\text{CFCF}_2\text{CF}_2\text{CF}_3$	1,2,3,3,4,4,5,5,5-nonafluoro-1-pentene
HFC-1429czc	$\text{CF}_2=\text{CHCF}_2\text{CF}_2\text{CF}_3$	1,1,3,3,4,4,5,5,5-nonafluoro-1-pentene
HFC-1429cycc	$\text{CF}_2=\text{CFCF}_2\text{CF}_2\text{CHF}_2$	1,1,2,3,3,4,4,5,5-nonafluoro-1-pentene
HFC-1429pyy	$\text{CHF}_2\text{CF}=\text{CFCF}_2\text{CF}_3$	1,1,2,3,4,4,5,5,5-nonafluoro-2-pentene
HFC-1429myyc	$\text{CF}_3\text{CF}=\text{CFCF}_2\text{CHF}_2$	1,1,1,2,3,4,4,5,5-nonafluoro-2-pentene
HFC-1429myye	$\text{CF}_3\text{CF}=\text{CFCHFCF}_3$	1,1,1,2,3,4,5,5,5-nonafluoro-2-pentene
HFC-1429eyym	$\text{CHF}=\text{CFCF}(\text{CF}_3)_2$	1,2,3,4,4,4-hexafluoro-3-(trifluoromethyl)-1-butene

HFC-1429cyzm	$\text{CF}_2=\text{CFCH}(\text{CF}_3)_2$	1,1,2,4,4,4-hexafluoro-3-(trifluoromethyl)-1-butene
HFC-1429mzt	$\text{CF}_3\text{CH}=\text{C}(\text{CF}_3)_2$	1,1,1,4,4,4-hexafluoro-2-(trifluoromethyl)-2-butene
HFC-1429czym	$\text{CF}_2=\text{CHCF}(\text{CF}_3)_2$	1,1,3,4,4,4-hexafluoro-3-(trifluoromethyl)-1-butene
HFC-1438fy	$\text{CH}_2=\text{CFCF}_2\text{CF}_2\text{CF}_3$	2,3,3,4,4,5,5-octafluoro-1-pentene
HFC-1438eycc	$\text{CHF}=\text{CFCF}_2\text{CF}_2\text{CHF}_2$	1,2,3,3,4,4,5,5-octafluoro-1-pentene
HFC-1438ftmc	$\text{CH}_2=\text{C}(\text{CF}_3)\text{CF}_2\text{CF}_3$	3,3,4,4,4-pentafluoro-2-(trifluoromethyl)-1-butene
HFC-1438czzm	$\text{CF}_2=\text{CHCH}(\text{CF}_3)_2$	1,1,4,4,4-pentafluoro-3-(trifluoromethyl)-1-butene
HFC-1438ezym	$\text{CHF}=\text{CHCF}(\text{CF}_3)_2$	1,3,4,4,4-pentafluoro-3-(trifluoromethyl)-1-butene
HFC-1438ctmf	$\text{CF}_2=\text{C}(\text{CF}_3)\text{CH}_2\text{CF}_3$	1,1,4,4,4-pentafluoro-2-(trifluoromethyl)-1-butene
HFC-1447fzy	$(\text{CF}_3)_2\text{CFCH}=\text{CH}_2$	3,4,4,4-tetrafluoro-3-(trifluoromethyl)-1-butene
HFC-1447fz	$\text{CF}_3\text{CF}_2\text{CF}_2\text{CH}=\text{CH}_2$	3,3,4,4,5,5,5-heptafluoro-1-pentene
HFC-1447fycc	$\text{CH}_2=\text{CFCF}_2\text{CF}_2\text{CHF}_2$	2,3,3,4,4,5,5-heptafluoro-1-pentene
HFC-1447czcf	$\text{CF}_2=\text{CHCF}_2\text{CH}_2\text{CF}_3$	1,1,3,3,5,5,5-heptafluoro-1-pentene
HFC-1447mytm	$\text{CF}_3\text{CF}=\text{C}(\text{CF}_3)(\text{CH}_3)$	1,1,1,2,4,4,4-heptafluoro-3-methyl-2-butene
HFC-1447fyz	$\text{CH}_2=\text{CFCH}(\text{CF}_3)_2$	2,4,4,4-tetrafluoro-3-(trifluoromethyl)-1-butene
HFC-1447ezz	$\text{CHF}=\text{CHCH}(\text{CF}_3)_2$	1,4,4,4-tetrafluoro-3-(trifluoromethyl)-1-butene
HFC-1447qzt	$\text{CH}_2\text{FCH}=\text{C}(\text{CF}_3)_2$	1,4,4,4-tetrafluoro-2-(trifluoromethyl)-2-butene
HFC-1447syt	$\text{CH}_3\text{CF}=\text{C}(\text{CF}_3)_2$	2,4,4,4-tetrafluoro-2-(trifluoromethyl)-2-butene
HFC-1456szt	$(\text{CF}_3)_2\text{C}=\text{CHCH}_3$	3-(trifluoromethyl)-4,4,4-trifluoro-2-butene
HFC-1456szy	$\text{CF}_3\text{CF}_2\text{CF}=\text{CHCH}_3$	3,4,4,5,5,5-hexafluoro-2-pentene
HFC-1456mstz	$\text{CF}_3\text{C}(\text{CH}_3)=\text{CHCF}_3$	1,1,1,4,4,4-hexafluoro-2-methyl-2-butene
HFC-1456fzce	$\text{CH}_2=\text{CHCF}_2\text{CHFCF}_3$	3,3,4,5,5,5-hexafluoro-1-pentene
HFC-1456ftmf	$\text{CH}_2=\text{C}(\text{CF}_3)\text{CH}_2\text{CF}_3$	4,4,4-trifluoro-2-(trifluoromethyl)-1-butene
FC-151-12c	$\text{CF}_3(\text{CF}_2)_3\text{CF}=\text{CF}_2$	1,1,2,3,3,4,4,5,5,6,6,6-dodecafluoro-1-hexene (or perfluoro-1-hexene)

FC-151-12mcy	$\text{CF}_3\text{CF}_2\text{CF}=\text{CFCF}_2\text{CF}_3$	1,1,1,2,2,3,4,5,5,6,6,6-dodecafluoro-3-hexene (or perfluoro-3-hexene)
FC-151-12mmtt	$(\text{CF}_3)_2\text{C}=\text{C}(\text{CF}_3)_2$	1,1,1,4,4,4-hexafluoro-2,3-bis(trifluoromethyl)-2-butene
FC-151-12mmzz	$(\text{CF}_3)_2\text{CFCF}=\text{CFCF}_3$	1,1,1,2,3,4,5,5,5-nonafluoro-4-(trifluoromethyl)-2-pentene
HFC-152-11mmtz	$(\text{CF}_3)_2\text{C}=\text{CHC}_2\text{F}_5$	1,1,1,4,4,5,5,5-octafluoro-2-(trifluoromethyl)-2-pentene
HFC-152-11mmyyz	$(\text{CF}_3)_2\text{CFCF}=\text{CHCF}_3$	1,1,1,3,4,5,5,5-octafluoro-4-(trifluoromethyl)-2-pentene
PFBE (or HFC-1549fz)	$\text{CF}_3\text{CF}_2\text{CF}_2\text{CF}_2\text{CH}=\text{CH}_2$	3,3,4,4,5,5,6,6-nonafluoro-1-hexene (or perfluorobutylethylene)
HFC-1549fzttmm	$\text{CH}_2=\text{CHC}(\text{CF}_3)_3$	4,4,4-trifluoro-3,3-bis(trifluoromethyl)-1-butene
HFC-1549mmtts	$(\text{CF}_3)_2\text{C}=\text{C}(\text{CH}_3)(\text{CF}_3)$	1,1,1,4,4,4-hexafluoro-3-methyl-2-(trifluoromethyl)-2-butene
HFC-1549fycz	$\text{CH}_2=\text{CFCF}_2\text{CH}(\text{CF}_3)_2$	2,3,3,5,5,5-hexafluoro-4-(trifluoromethyl)-1-pentene
HFC-1549myts	$\text{CF}_3\text{CF}=\text{C}(\text{CH}_3)\text{CF}_2\text{CF}_3$	1,1,1,2,4,4,5,5,5-nonafluoro-3-methyl-2-pentene
HFC-1549mzzz	$\text{CF}_3\text{CH}=\text{CHCH}(\text{CF}_3)_2$	1,1,1,5,5,5-hexafluoro-4-(trifluoromethyl)-2-pentene
HFC-1558szy	$\text{CF}_3\text{CF}_2\text{CF}_2\text{CF}=\text{CHCH}_3$	3,4,4,5,5,6,6,6-octafluoro-2-hexene
HFC-1558fzccc	$\text{CH}_2=\text{CHCF}_2\text{CF}_2\text{CF}_2\text{CHF}_2$	3,3,4,4,5,5,6,6-octafluoro-2-hexene
HFC-1558mmtzc	$(\text{CF}_3)_2\text{C}=\text{CHCF}_2\text{CH}_3$	1,1,1,4,4-pentafluoro-2-(trifluoromethyl)-2-pentene
HFC-1558ftmf	$\text{CH}_2=\text{C}(\text{CF}_3)\text{CH}_2\text{C}_2\text{F}_5$	4,4,5,5,5-pentafluoro-2-(trifluoromethyl)-1-pentene
HFC-1567fts	$\text{CF}_3\text{CF}_2\text{CF}_2\text{C}(\text{CH}_3)=\text{CH}_2$	3,3,4,4,5,5,5-heptafluoro-2-methyl-1-pentene
HFC-1567szz	$\text{CF}_3\text{CF}_2\text{CF}_2\text{CH}=\text{CHCH}_3$	4,4,5,5,6,6,6-heptafluoro-2-hexene
HFC-1567fzfc	$\text{CH}_2=\text{CHCH}_2\text{CF}_2\text{C}_2\text{F}_5$	4,4,5,5,6,6,6-heptafluoro-1-hexene
HFC-1567sfyy	$\text{CF}_3\text{CF}_2\text{CF}=\text{CFC}_2\text{H}_5$	1,1,1,2,2,3,4-heptafluoro-3-hexene
HFC-1567fzfy	$\text{CH}_2=\text{CHCH}_2\text{CF}(\text{CF}_3)_2$	4,5,5,5-tetrafluoro-4-(trifluoromethyl)-1-pentene
HFC-1567myzmm	$\text{CF}_3\text{CF}=\text{CHCH}(\text{CF}_3)(\text{CH}_3)$	1,1,1,2,5,5,5-heptafluoro-4-methyl-2-pentene
HFC-1567mmytf	$(\text{CF}_3)_2\text{C}=\text{CFC}_2\text{H}_5$	1,1,1,3-tetrafluoro-2-(trifluoromethyl)-2-

		pentene
FC-161-14myy	$\text{CF}_3\text{CF}=\text{CFCF}_2\text{CF}_2\text{C}_2\text{F}_5$	1,1,1,2,3,4,4,5,5,6,6,7,7,7-tetradecafluoro-2-heptene
FC-161-14mcy	$\text{CF}_3\text{CF}_2\text{CF}=\text{CFCF}_2\text{C}_2\text{F}_5$	1,1,1,2,2,3,4,5,5,6,6,7,7,7-tetradecafluoro-2-heptene
HFC-162-13mzy	$\text{CF}_3\text{CH}=\text{CFCF}_2\text{CF}_2\text{C}_2\text{F}_5$	1,1,1,3,4,4,5,5,6,6,7,7,7-tridecafluoro-2-heptene
HFC162-13myz	$\text{CF}_3\text{CF}=\text{CHCF}_2\text{CF}_2\text{C}_2\text{F}_5$	1,1,1,2,4,4,5,5,6,6,7,7,7-tridecafluoro-2-heptene
HFC-162-13mcyz	$\text{CF}_3\text{CF}_2\text{CH}=\text{CFCF}_2\text{C}_2\text{F}_5$	1,1,1,2,2,4,5,5,6,6,7,7,7-tridecafluoro-3-heptene
HFC-162-13mcyz	$\text{CF}_3\text{CF}_2\text{CF}=\text{CHCF}_2\text{C}_2\text{F}_5$	1,1,1,2,2,3,5,5,6,6,7,7,7-tridecafluoro-3-heptene
PEVE	$\text{CF}_2=\text{CFOCF}_2\text{CF}_3$	pentafluoroethyl trifluorovinyl ether
PMVE	$\text{CF}_2=\text{CFOCF}_3$	trifluoromethyl trifluorovinyl ether

The compounds listed in Table 2 and Table 3 are available commercially or may be prepared by processes known in the art or as described herein.

5 1,1,1,4,4-pentafluoro-2-butene may be prepared from 1,1,1,2,4,4-hexafluorobutane ($\text{CHF}_2\text{CH}_2\text{CHF}_2\text{CF}_3$) by dehydrofluorination over solid KOH in the vapor phase at room temperature. The synthesis of 1,1,1,2,4,4-hexafluorobutane is described in US 6,066,768.

10 1,1,1,4,4,4-hexafluoro-2-butene may be prepared from 1,1,1,4,4,4-hexafluoro-2-iodobutane ($\text{CF}_3\text{CHICH}_2\text{CF}_3$) by reaction with KOH using a phase transfer catalyst at about 60°C. The synthesis of 1,1,1,4,4,4-hexafluoro-2-iodobutane may be carried out by reaction of perfluoromethyl iodide (CF_3I) and 3,3,3-trifluoropropene ($\text{CF}_3\text{CH}=\text{CH}_2$) at about 200°C
15 under autogenous pressure for about 8 hours.

3,4,4,5,5,5-hexafluoro-2-pentene may be prepared by dehydrofluorination of 1,1,1,2,2,3,3-heptafluoropentane ($\text{CF}_3\text{CF}_2\text{CF}_2\text{CH}_2\text{CH}_3$) using solid KOH or over a carbon catalyst at 200-300 °C. 1,1,1,2,2,3,3-heptafluoropentane may be prepared by

hydrogenation of 3,3,4,4,5,5,5-heptafluoro-1-pentene
($\text{CF}_3\text{CF}_2\text{CF}_2\text{CH}=\text{CH}_2$).

1,1,1,2,3,4-hexafluoro-2-butene may be prepared by
dehydrofluorination of 1,1,1,2,3,3,4-heptafluorobutane ($\text{CH}_2\text{FCF}_2\text{CHF}_2\text{CF}_3$)
5 using solid KOH.

1,1,1,2,4-hexafluoro-2-butene may be prepared by
dehydrofluorination of 1,1,1,2,2,4,4-heptafluorobutane ($\text{CHF}_2\text{CH}_2\text{CF}_2\text{CF}_3$)
using solid KOH.

1,1,1,3,4,4-hexafluoro-2-butene may be prepared by
10 dehydrofluorination of 1,1,1,3,3,4,4-heptafluorobutane ($\text{CF}_3\text{CH}_2\text{CF}_2\text{CHF}_2$)
using solid KOH.

1,1,1,2,4-pentafluoro-2-butene may be prepared by
dehydrofluorination of 1,1,1,2,2,3-hexafluorobutane ($\text{CH}_2\text{FCH}_2\text{CF}_2\text{CF}_3$)
using solid KOH.

15 1,1,1,3,4-pentafluoro-2-butene may be prepared by
dehydrofluorination of 1,1,1,3,3,4-hexafluorobutane ($\text{CF}_3\text{CH}_2\text{CF}_2\text{CH}_2\text{F}$)
using solid KOH.

1,1,1,3-tetrafluoro-2-butene may be prepared by reacting 1,1,1,3,3-
pentafluorobutane ($\text{CF}_3\text{CH}_2\text{CF}_2\text{CH}_3$) with aqueous KOH at 120 °C.

20 1,1,1,4,4,5,5,5-octafluoro-2-pentene may be prepared from
($\text{CF}_3\text{CHICH}_2\text{CF}_2\text{CF}_3$) by reaction with KOH using a phase transfer catalyst
at about 60°C. The synthesis of 4-iodo-1,1,1,2,2,5,5,5-octafluoropentane
may be carried out by reaction of perfluoroethyl iodide ($\text{CF}_3\text{CF}_2\text{I}$) and 3,3,3-
trifluoropropene at about 200°C under autogenous pressure for about 8
25 hours.

1,1,1,2,2,5,5,6,6,6-decafluoro-3-hexene may be prepared from
1,1,1,2,2,5,5,6,6,6-decafluoro-3-iodohexane ($\text{CF}_3\text{CF}_2\text{CHICH}_2\text{CF}_2\text{CF}_3$) by
reaction with KOH using a phase transfer catalyst at about 60°C. The
synthesis of 1,1,1,2,2,5,5,6,6,6-decafluoro-3-iodohexane may be carried
30 out by reaction of perfluoroethyl iodide ($\text{CF}_3\text{CF}_2\text{I}$) and 3,3,4,4,4-
pentafluoro-1-butene ($\text{CF}_3\text{CF}_2\text{CH}=\text{CH}_2$) at about 200°C under autogenous
pressure for about 8 hours.

1,1,1,4,5,5,5-heptafluoro-4-(trifluoromethyl)-2-pentene may be prepared by the dehydrofluorination of 1,1,1,2,5,5,5-heptafluoro-4-iodo-2-(trifluoromethyl)-pentane ($\text{CF}_3\text{CHICH}_2\text{CF}(\text{CF}_3)_2$) with KOH in isopropanol. $\text{CF}_3\text{CHICH}_2\text{CF}(\text{CF}_3)_2$ is made from reaction of $(\text{CF}_3)_2\text{CFI}$ with $\text{CF}_3\text{CH}=\text{CH}_2$ at high temperature, such as about 200 °C.

1,1,1,4,4,5,5,6,6-decafluoro-2-hexene may be prepared by the reaction of 1,1,1,4,4,4-hexafluoro-2-butene ($\text{CF}_3\text{CH}=\text{CHCF}_3$) with tetrafluoroethylene ($\text{CF}_2=\text{CF}_2$) and antimony pentafluoride (SbF_5).

2,3,3,4,4-pentafluoro-1-butene may be prepared by dehydrofluorination of 1,1,2,2,3,3-hexafluorobutane over fluorided alumina at elevated temperature.

2,3,3,4,4,5,5-ocatafluoro-1-pentene may be prepared by dehydrofluorination of 2,2,3,3,4,4,5,5,5-nonafluoropentane over solid KOH.

1,2,3,3,4,4,5,5-octafluoro-1-pentene may be prepared by dehydrofluorination of 2,2,3,3,4,4,5,5,5-nonafluoropentane over fluorided alumina at elevated temperature.

Many of the compounds of Formula I, Formula II, Table 1, Table 2, and Table 3 exist as different configurational isomers or stereoisomers. When the specific isomer is not designated, the described composition is intended to include all single configurational isomers, single stereoisomers, or any combination thereof. For instance, F11E is meant to represent the *E*-isomer, *Z*-isomer, or any combination or mixture of both isomers in any ratio. As another example, HFC-1225ye is meant to represent the *E*-isomer, *Z*-isomer, or any combination or mixture of both isomers in any ratio, with the *Z* isomer preferred.

In some embodiments, the working fluid may further comprise at least one compound selected from hydrofluorocarbons, fluoroethers, hydrocarbons, dimethyl ether (DME), carbon dioxide (CO_2), ammonia (NH_3), and iodotrifluoromethane (CF_3I).

In some embodiments, the working fluid may further comprise hydrofluorocarbons comprising at least one saturated compound containing carbon, hydrogen, and fluorine. Of particular utility are

hydrofluorocarbons having 1 to 7 carbon atoms and having a normal boiling point of from about -90°C to about 80°C. Hydrofluorocarbons are commercial products available from a number of sources or may be prepared by methods known in the art. Representative hydrofluorocarbon compounds include but are not limited to fluoromethane (CH₃F, HFC-41),
5 difluoromethane (CH₂F₂, HFC-32), trifluoromethane (CHF₃, HFC-23), pentafluoroethane (CF₃CHF₂, HFC-125), 1,1,2,2-tetrafluoroethane (CHF₂CHF₂, HFC-134), 1,1,1,2-tetrafluoroethane (CF₃CH₂F, HFC-134a), 1,1,1-trifluoroethane (CF₃CH₃, HFC-143a), 1,1-difluoroethane (CHF₂CH₃,
10 HFC-152a), fluoroethane (CH₃CH₂F, HFC-161), 1,1,1,2,2,3,3-heptafluoropropane (CF₃CF₂CHF₂, HFC-227ca), 1,1,1,2,3,3,3-heptafluoropropane (CF₃CHF₂CF₃, HFC-227ea), 1,1,2,2,3,3,3-hexafluoropropane (CHF₂CF₂CHF₂, HFC-236ca), 1,1,1,2,2,3-hexafluoropropane (CF₃CF₃CH₂F, HFC-236cb), 1,1,1,2,3,3-hexafluoropropane (CF₃CHFCHF₂, HFC-236ea), 1,1,1,3,3,3-hexafluoropropane (CF₃CH₂CF₃, HFC-236fa), 1,1,2,2,3-pentafluoropropane (CHF₂CF₂CH₂F, HFC-245ca), 1,1,1,2,2-pentafluoropropane (CF₃CF₂CH₃, HFC-245cb), 1,1,2,3,3-pentafluoropropane (CHF₂CHFCHF₂, HFC-245ea), 1,1,1,2,3-pentafluoropropane (CF₃CHFCH₂F, HFC-245eb), 1,1,1,3,3-pentafluoropropane (CF₃CH₂CHF₂, HFC-245fa), 1,2,2,3-tetrafluoropropane (CH₂FCF₂CH₂F, HFC-254ca), 1,1,2,2-tetrafluoropropane (CHF₂CF₂CH₃, HFC-254cb), 1,1,2,3-tetrafluoropropane (CHF₂CHFCH₂F, HFC-254ea), 1,1,1,2-tetrafluoropropane (CF₃CHFCH₃,
25 HFC-254eb), 1,1,3,3-tetrafluoropropane (CHF₂CH₂CHF₂, HFC-254fa), 1,1,1,3-tetrafluoropropane (CF₃CH₂CH₂F, HFC-254fb), 1,1,1-trifluoropropane (CF₃CH₂CH₃, HFC-263fb), 2,2-difluoropropane (CH₃CF₂CH₃, HFC-272ca), 1,2-difluoropropane (CH₂FCHFCH₃, HFC-272ea), 1,3-difluoropropane (CH₂FCH₂CH₂F, HFC-272fa), 1,1-difluoropropane (CHF₂CH₂CH₃, HFC-272fb), 2-fluoropropane (CH₃CHFCH₃, HFC-281ea), 1-fluoropropane (CH₂FCH₂CH₃, HFC-281fa),
30 1,1,2,2,3,3,4,4-octafluorobutane (CHF₂CF₂CF₂CHF₂, HFC-338pcc),

1,1,1,2,2,4,4,4-octafluorobutane ($\text{CF}_3\text{CH}_2\text{CF}_2\text{CF}_3$, HFC-338mf), 1,1,1,3,3,3-pentafluorobutane ($\text{CF}_3\text{CH}_2\text{CHF}_2$, HFC-365mfc), 1,1,1,2,3,4,4,5,5,5-decafluoropentane ($\text{CF}_3\text{CHFCHFCF}_2\text{CF}_3$, HFC-43-10mee), and
1,1,1,2,2,3,4,5,5,6,6,7,7,7-tetradecafluoroheptane
5 ($\text{CF}_3\text{CF}_2\text{CHFCHFCF}_2\text{CF}_2\text{CF}_3$, HFC-63-14mee).

In some embodiments, working fluids may further comprise fluoroethers comprising at least one compound having carbon, fluorine, oxygen and optionally hydrogen, chlorine, bromine or iodine. Fluoroethers are commercially available or may be produced by methods known in the
10 art. Representative fluoroethers include but are not limited to nonafluoromethoxybutane ($\text{C}_4\text{F}_9\text{OCH}_3$, any or all possible isomers or mixtures thereof); nonafluoroethoxybutane ($\text{C}_4\text{F}_9\text{OC}_2\text{H}_5$, any or all possible isomers or mixtures thereof); 2-difluoromethoxy-1,1,1,2-tetrafluoroethane (HFOC-236eaE $\beta\gamma$, or $\text{CHF}_2\text{OCHF}_2\text{CF}_3$); 1,1-difluoro-2-methoxyethane
15 (HFOC-272fbE $\beta\gamma$, $\text{CH}_3\text{OCH}_2\text{CHF}_2$); 1,1,1,3,3,3-hexafluoro-2-(fluoromethoxy)propane (HFOC-347mmzE $\beta\gamma$, or $\text{CH}_2\text{FOCH}(\text{CF}_3)_2$); 1,1,1,3,3,3-hexafluoro-2-methoxypropane (HFOC-356mmzE $\beta\gamma$, or $\text{CH}_3\text{OCH}(\text{CF}_3)_2$); 1,1,1,2,2-pentafluoro-3-methoxypropane (HFOC-365mcE $\gamma\delta$, or $\text{CF}_3\text{CF}_2\text{CH}_2\text{OCH}_3$); 2-ethoxy-1,1,1,2,3,3,3-
20 heptafluoropropane (HFOC-467mmyE $\beta\gamma$, or $\text{CH}_3\text{CH}_2\text{OCF}(\text{CF}_3)_2$; and mixtures thereof.

In some embodiments, working fluids may further comprise hydrocarbons comprising compounds having only carbon and hydrogen. Of particular utility are compounds having 3 to 7 carbon atoms.
25 Hydrocarbons are commercially available through numerous chemical suppliers. Representative hydrocarbons include but are not limited to propane, n-butane, isobutane, cyclobutane, n-pentane, 2-methylbutane, 2,2-dimethylpropane, cyclopentane, n-hexane, 2-methylpentane, 2,2-dimethylbutane, 2,3-dimethylbutane, 3-methylpentane, cyclohexane, n-
30 heptane, and cycloheptane.

In some embodiments, the working fluid may comprise hydrocarbons containing heteroatoms, such as dimethylether (DME, CH_3OCH_3). DME is commercially available.

5 In some embodiments, working fluids may further comprise carbon dioxide (CO_2), which is commercially available from various sources or may be prepared by methods known in the art.

In some embodiments, working fluids may further comprise ammonia (NH_3), which is commercially available from various sources or may be prepared by methods known in the art.

10 In some embodiments, the working fluid further comprises at least one compound selected from hydrofluorocarbons, fluoroethers, hydrocarbons, dimethyl ether (DME), carbon dioxide (CO_2), ammonia (NH_3), and iodotrifluoromethane (CF_3I).

15 In one embodiment, the working fluid comprises 1,2,3,3,3-pentafluoropropene (HFC-1225ye). In another embodiment, the working fluid further comprises difluoromethane (HFC-32). In yet another embodiment, the working fluid further comprises 1,1,1,2-tetrafluoroethane (HFC-134a).

20 In one embodiment, the working fluid comprises 2,3,3,3-tetrafluoropropene (HFC-1234yf). In another embodiment, the working fluid comprises HFC-1225ye and HFC-1234yf.

In one embodiment, the working fluid comprises 1,3,3,3-tetrafluoropropene (HFC-1234ze). In another embodiment, the working fluid comprises E-HFC-1234ze (or trans-HFC-1234ze).

25 In yet another embodiment, the working fluid further comprises at least one compound from the group consisting of HFC-134a, HFC-32, HFC-125, HFC-152a, and CF_3I .

In certain embodiments, working fluids may comprise a composition selected from the group consisting of:

30 HFC-32 and HFC-1225ye;

HFC-1234yf and CF_3I ;

HFC-32, HFC-134a, and HFC-1225ye;

- HFC-32, HFC-125, and HFC-1225ye;
HFC-32, HFC-1225ye, and HFC-1234yf;
HFC-125, HFC-1225ye, and HFC-1234yf;
HFC-32, HFC-1225ye, HFC-1234yf, and CF₃I;
- 5 HFC-134a, HFC-1225ye, and HFC-1234yf;
HFC-134a and HFC-1234yf;
HFC-32 and HFC-1234yf;
HFC-125 and HFC-1234yf;
HFC-32, HFC-125, and HFC-1234yf;
- 10 HFC-32, HFC-134a, and HFC-1234yf;
DME and HFC-1234yf;
HFC-152a and HFC-1234yf;
HFC-152a, HFC-134a, and HFC-1234yf;
HFC-152a, n-butane, and HFC-1234yf;
- 15 HFC-134a, propane, and HFC-1234yf;
HFC-125, HFC-152a, and HFC-1234yf;
HFC-125, HFC-134a, and HFC-1234yf;
HFC-32, HFC-1234ze, and HFC-1234yf;
HFC-125, HFC-1234ze, and HFC-1234yf;
- 20 HFC-32, HFC-1234ze, HFC-1234yf, and CF₃I;
HFC-134a, HFC-1234ze, and HFC-1234yf;
HFC-134a and HFC-1234ze;
HFC-32 and HFC-1234ze;
HFC-125 and HFC-1234ze;
- 25 HFC-32, HFC-125, and HFC-1234ze;
HFC-32, HFC-134a, and HFC-1234ze;
DME and HFC-1234ze;
HFC-152a and HFC-1234ze;
HFC-152a, HFC-134a, and HFC-1234ze;
- 30 HFC-152a, n-butane, and HFC-1234ze;
HFC-134a, propane, and HFC-1234ze;
HFC-125, HFC-152a, and HFC-1234ze; or

HFC-125, HFC-134a, and HFC-1234ze.

EXAMPLES

EXAMPLE 1

Performance comparison

5 Automobile air conditioning systems with and without an intermediate heat exchanger were tested to determine if an improvement is seen with the IHX. The working fluid was a blend of 95% by weight
10 HFC-1225ye and 5% by weight of HFC-32. Each system had a condenser, evaporator, compressor and a thermal expansion device. The ambient air temperature was 30 °C at the evaporator and the condenser inlets. Tests were performed for 2 compressor speeds, 1000 and 2000 rpm, and for 3 vehicle speeds: 25, 30, and 36 km/h. The volumetric flow
15 rate of air on the evaporator was 380 m³/h.

The cooling capacity for the system with an IHX shows an increase of 4 to 7% as compared to the system with no IHX. The COP also showed an increase of 2.5 to 4% for the system with the IHX as compared to a system with no IHX.

20

EXAMPLE 2

Improvement in performance with internal heat exchanger

Cooling performance is calculated for HFC-134a and HFC-1234yf both with and without an IHX. The conditions used are as follows:

25

Condenser temperature	55 ° C
Evaporator temperature	5 ° C
Superheat (absolute)	15 ° C

The data illustrating relative performance is shown in TABLE 5.

30

TABLE 5

Test	Subcool, ° C	COP	Capacity kJ/m ³	Compressor work, kJ/kg
HFC-134a, without IHX	0	4.74	2250.86	29.6
HFC-134a, with IHX	5.0	5.02	2381.34	29.6
HFC-134a, % increase with IHX		5.91	5.80	
HFC-1234yf, without IHX	0	4.64	2172.43	24.37
HFC-1234yf with IHX	5.8	5.00	2335.38	24.37
HFC-1234yf, % increase with IHX		7.76	7.50	

The data above demonstrate an unexpected level of improvement in energy efficiency (COP) and cooling capacity for the fluoroolefin (HFC-1234yf) with the IHX, as compared to that gained by HFC-134a with the IHX. In particular, COP was increased by 7.67% and cooling capacity increased by 7.50%.

It should be noted that the subcooling difference arises from the differences in molecular weight, liquid density and liquid heat capacity for HFC-1234yf as compared to HFC-134a. Based on these parameters it was estimated that there would be a difference in subcooling achieved with the different compounds. When the HFC-134a subcool was set to 5 ° C, the corresponding subcooling for HFC-1234yf was calculated to be 5.8 ° C.

15

CLAIMS

What is claimed is:

1. A method for exchanging heat in a vapor compression heat transfer system having a working fluid comprising a fluoroolefin circulating therethrough, comprising the steps of:
 - (a) circulating a working fluid comprising a fluoroolefin, wherein the working fluid enters to an inlet of a first tube of an internal heat exchanger, passes through the internal heat exchanger and exits to an outlet thereof;
 - (b) circulating the working fluid from the outlet of the first tube of the internal heat exchanger, wherein the working fluid enters to an inlet of a dual-row evaporator, passes through the dual-row evaporator to evaporate the working fluid, thereby convert it into a gaseous working fluid, and exits through an outlet of the dual-row evaporator;
 - (c) circulating the working fluid from the outlet of the dual-row evaporator, wherein the working fluid enters to an inlet of a second tube of the internal heat exchanger to transfer heat from the liquid working fluid from the condenser to the gaseous working fluid from the dual-row evaporator, passes through the internal heat exchanger, and exits to an outlet of the second tube;
 - (d) circulating the working fluid from the outlet of the second tube of the internal heat exchanger, wherein the working fluid enters to an inlet of a compressor, passes through the compressor to compress the gaseous working fluid, and exits to an outlet of the compressor;
 - (e) circulating the working fluid from the outlet of the compressor, wherein the working fluid enters to an inlet of a condenser and passes through the condenser to condense the compressed gaseous working fluid into a liquid, and exits to an outlet of the condenser;
 - (f) circulating the working fluid from the outlet of the condenser, wherein the working fluid enters the inlet of the first tube of the internal heat exchanger to transfer heat from the liquid from the condenser to the gas from the dual-row evaporator, and exits to the outlet of the first tube; and

(g) circulating the working fluid from the outlet of the first tube of the internal heat exchanger back to the dual-row evaporator;

wherein the evaporating step comprises:

(i) passing the working fluid through the inlet of the dual-row evaporator having a first row and a second row,

(ii) circulating the working fluid in the first row in a direction perpendicular to the flow of fluid through the inlet of the dual-row evaporator, and

(iii) circulating the working fluid in the second row in a direction generally counter to the direction of the flow of the working fluid through the inlet of the dual-row evaporator;

wherein the working fluid in the second tube flows in a countercurrent direction to the direction of flow of the working fluid in the first tube which is relatively hotter than the working fluid in the second tube to transfer heat from the working fluid in the first tube to the working fluid in the second tube, thereby cooling the working fluid in the first tube and heating the working fluid in the second tube; the fluoroolefin comprises HFC-1234yf, where the first tube has a larger diameter than the second tube, and the second tube is disposed concentrically in the first tube, and a hot liquid working fluid in the first tube surrounds a cool gaseous working fluid in the second tube; and the coefficient of performance and the cooling capacity of the system is increased by at least 7.5% as compared to the same system except for using HFC-134a as the working fluid.

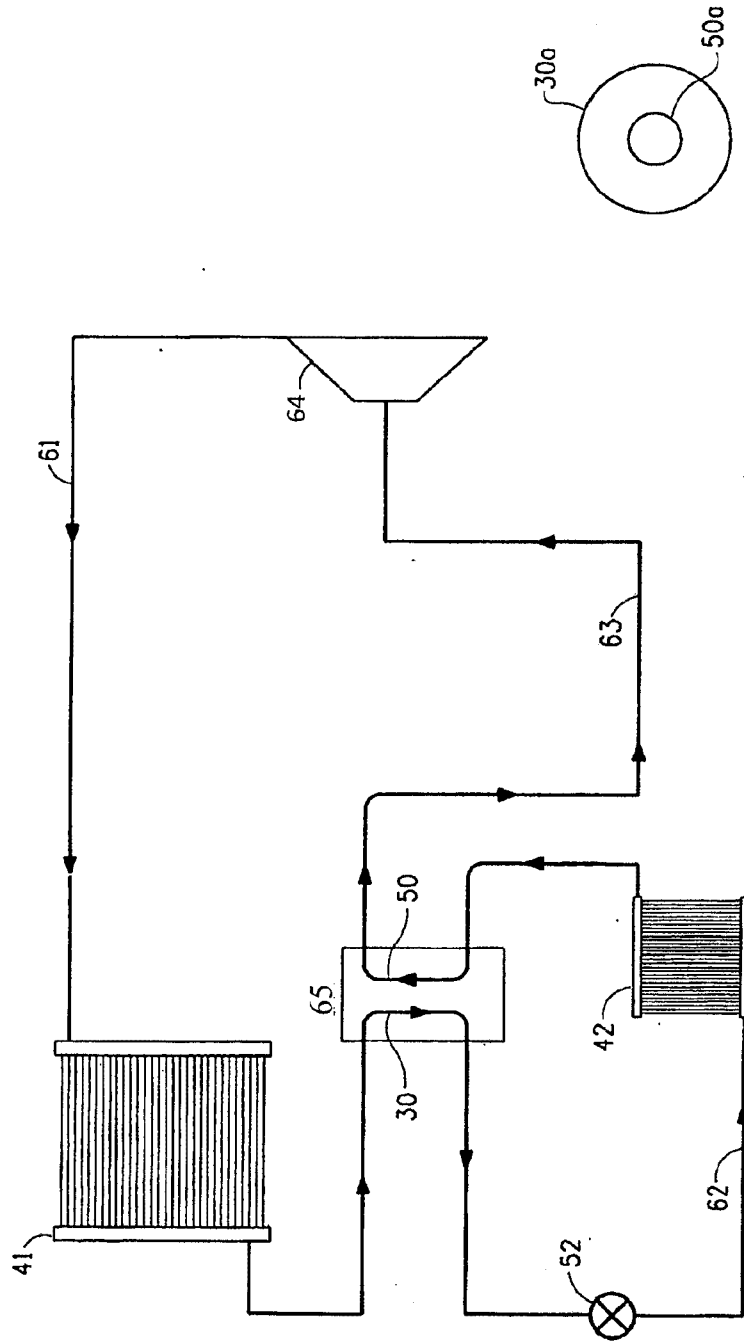
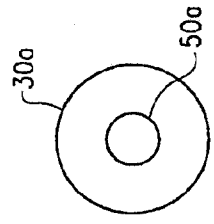

FIG. 1A

FIG. 1



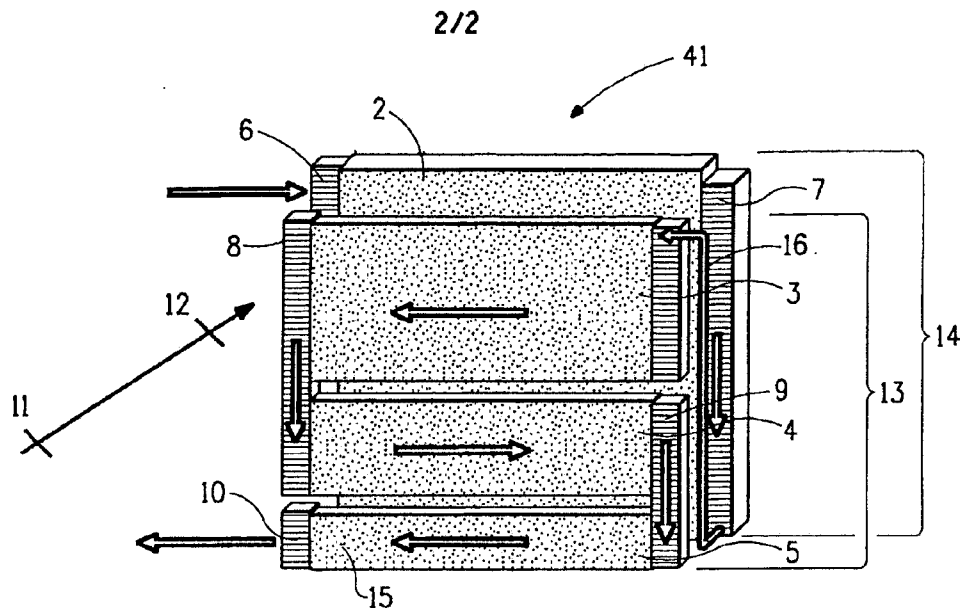

FIG. 2

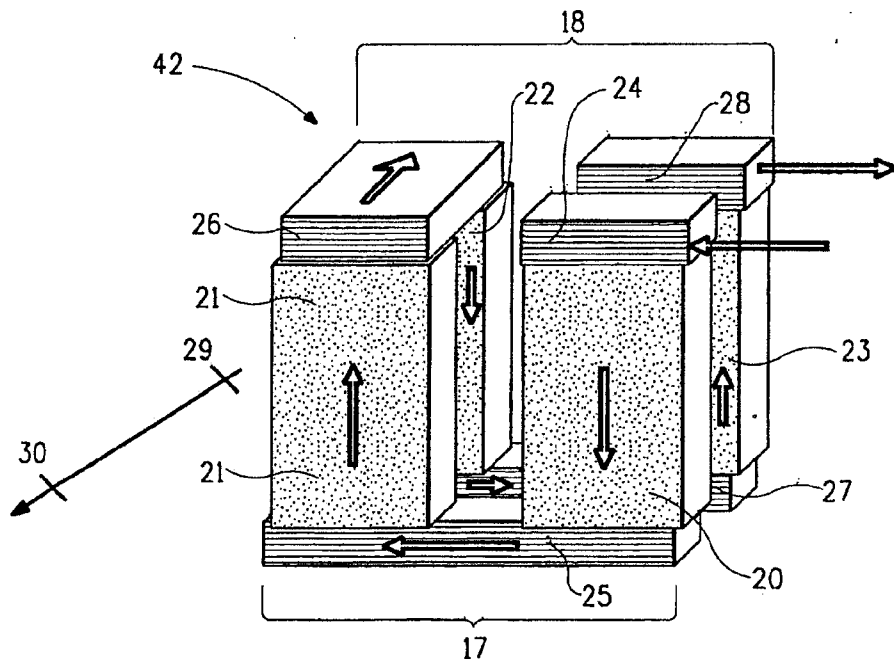

FIG. 3

