



(12) EUROPEAN PATENT APPLICATION

(43) Date of publication:
23.09.1998 Bulletin 1998/39

(51) Int Cl. 6: A45D 40/06

(21) Application number: 98500016.5

(22) Date of filing: 26.01.1998

(84) Designated Contracting States:
AT BE CH DE DK ES FI FR GB GR IE IT LI LU MC
NL PT SE
Designated Extension States:
AL LT LV MK RO SI

(71) Applicant: Techpack Espana S.L.
08030 Barcelona (ES)

(72) Inventor: Monin-Bareil, Richard
08190 San Cugat Del Valles, Barcelona (ES)

(30) Priority: 03.02.1997 ES 9700258 U
27.10.1997 ES 9702752

(74) Representative: Gonzalez Vacas, Eleuterio
Calle Sagasta, 4
28004 Madrid (ES)

(54) Improved mechanical container for barshaped products

(57) The invention proposes a mechanical container for products shaped in the form of a bar, the container body and/or the closing cap incorporating respective nerves which adapt onto one another and secure the

cap in the closed position of the container and thus provide a means of attachment for the two parts. Furthermore, one of the parts, either the body or the cap, is fitted with an attachment groove for receiving a nerve or projection emerging from the other body.

FIG.1

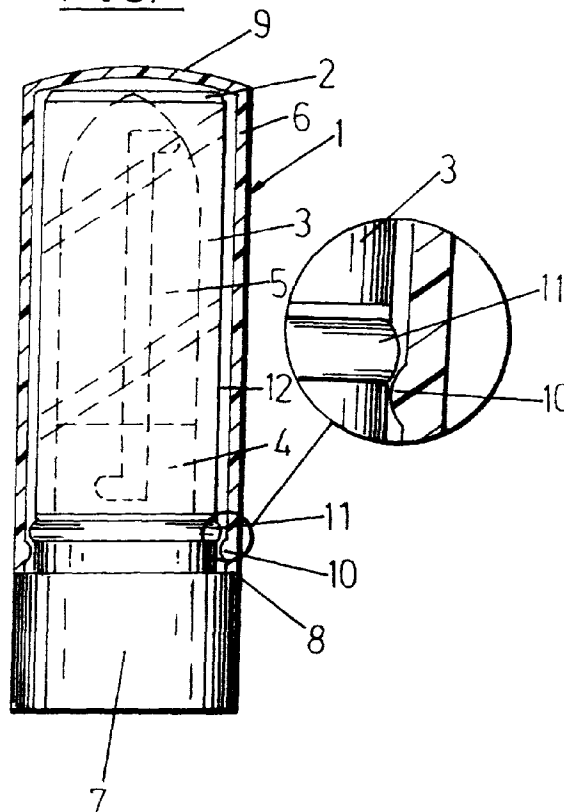

Description

OBJECT OF THE INVENTION

This invention is generally related to containers for products shaped in the form of a bar. More specifically, and as a result of a new industrial feature, this invention is related to mechanical containers used for lipstick, wherein the bar or lipstick moves axially outward from the container when in use or back inward for protection.

The improvements provided by the invention involve the sliding means in the closing cap along the body of the container and its effective and reliable hold between the container body and the closing element.

BACKGROUND OF THE INVENTION

Known lipstick or bar-shaped product cases are formed by two cylindrical tubular bodies adapted to each other in a concentric arrangement which allows for independent rotational and straight-line alternative axial movement of an internal holder lodging the bar of product to be applied.

The external tubular body is fitted along its internal wall with a pair of diametrically opposite helicoidal grooves which extend longitudinally in diametrically opposite zones of said tubular body. This inner body is generally fitted with an externally grooved extension at its lower end that is either fixed or added to it, normally of a larger diameter, which constitutes the driving portion for the exit or retraction of the product bar. Lodged inside the body formed by said two concentric cylindrical tubes lies a small part in the form of a holder with a cylindrical tubular section which adequately retains the bar or lipstick. From the periphery of this holder, a pair of diametrically opposite stubs project radially, extending through the grooves in the tubular inner body and thereafter securing their free end inside the helicoidal channels in the external cylindrical body in a manner that, upon rotating the external tubular body in respect to the inner grooved body, the holder and the product bar move in one direction or the other, extending out of or retracting into the container.

The two concentric tubular elements forming the body of the container are reciprocally in contact through a large cylindrical surface, so that the possibility exists of their becoming seized, the movement thus becoming impaired. To prevent this blocking, an adequate lubricant is generally applied between the two tubular bodies.

This solution presents the inconvenience that the container thus conditioned lets off undesired smells, particularly when the container holds products that are applied directly on the user's lips.

To solve these problems, the invention provides an effective solution in that it minimizes as far as possible the contact surface between both tubular bodies, allowing for a smooth sliding action between both parts.

A further object of the invention consists in reducing to a minimum the friction of the sliding closing cap moving along the tubular body which forms the container.

5 A further object of the invention consists in providing an effective attachment or retaining system between the container body and the closing cap.

A further object of the proposed container invention consists in providing a means of attachment between the container and the closing cap which allows for easy and smooth separation of the closing cap from the container body, when so desired.

10 A further object of the invention refers to the reinforcing means provided in the closing cap designed to avoid its breaking or tearing, thus ensuring its proper closure and preventing it from opening as a result of accidental release or separation of the protective cap.

15 Other objects related to the advantages provided by the invention are described further on.

20 One characteristic of the invention consists in improving the means of attachment between the container and the closing cap by fitting both parts with respective nerves, one on the external periphery of the container body and the other inside the closing cap, adjacent its open end.

25 Another characteristic of the invention consists in providing a peripheric channel or groove in the container body which acts as a routing means to receive an annular nerve with an appropriate dimension and section which projects from the inner wall of the container's closing cap.

30 A further characteristic of the invention relates to the nerve protruding from inside the closing cap, advantageously having a curvilinear section and a fine peripheric contact line along the container's cylindrical body to provide a smooth, oscillation-free sliding motion between the container and the closing cap, in addition to easy entry of the nerve in the attachment channel at the lower end of the container.

35 A further characteristic of the invention involves the formation of a contact-free gap between the container body and the closing cap.

40 A further characteristic of the invention provides the closing cap with a means of reinforcement which increases the cap's mechanical strength and prevents tearing or mismatch.

45 According to a further characteristic of the invention, the closing cap is optionally fitted with a channel or groove which coincides with a peripheric projection on the container body that lodges inside said closing cap groove, thereby establishing an attachment between these two elements.

DESCRIPTION OF THE INVENTION

55 The improved container advocated by the invention satisfactorily solves the problems discussed, which specifically affect the means of sliding and attachment between the container body and the closing cap.

The invention provides an improvement in that the container for bar-shaped products, preferably lipstick, has an external tubular body with inner helicoidal channels and advantageously possesses a peripheric projection along its lower area onto which the closing cap is coupled and duly retained in the closed position of the container.

According to the proposed embodiment, the tubular closing cap has a inner increased thickness or nerve adjacent the open end which directly leans on the exterior of the container body, over which it slides, providing a minimum annular friction surface and thus ensuring a very smooth sliding action. Upon mounting the cap in the closed position of the container, this annular projection, on contacting the peripheric nerve or projection on the body of the container, meets a light resistance along its trajectory and suffers a slight peripheric expansion allowed by the resiliency of the material used in its fabrication, overpassing said peripheric nerve which projects from the container body and becoming retained by it.

According to another improvement proposed by the invention, the external tubular body of the container, internally fitted with helicoidal channels near its lower end, has a peripheric groove or channel into which smoothly fits a coinciding nerve or projection inside the closure cap, said container channelling and the cap's inner nerve forming the smooth container/closing cap attachment system.

The invention also foresees the formation of a circular channel or groove along the inner cap wall, adjacent its open end, which coincides with a corresponding projection that lodges inside said cap channel and provides a means of attachment between both bodies, namely the container and the closing cap.

In order to facilitate as far as possible the understanding of the invention, reference is made to the attached drawings which schematically show the details and preferred assemblies in the improved container proposed by the invention.

DESCRIPTION OF THE DRAWINGS

Figure 1 shows an elevation view of a container of the type proposed by the invention, fitted with a closing cap adapted and secured in the manner shown in a vertical plane section.

The complementary figure, inside a circle, shows an enlarged detail of the container body and closing cap attachment system, revealing that both the container and the cap present respective annular projections which couple onto one another and hold both elements together when closed.

Figure 2 is similar to the preceding figure, the complementary figure showing an enlarged detail of the attachment device in which the channel lodging the attaching projection is formed in the closing cap.

Figure 3 shows an elevation view of a lipstick con-

tainer fitted with a closing cap shown in a vertical plane section. This figure depicts an arrangement of the closing cap attachment over the container body, the lower zone of which has a peripheric channel into which fits the closing cap nerve or projection, which is thus retained over the container body. This attachment detail of the two bodies can be seen in the complementary enlarged figure showing the attachment device.

Commenting on these drawings, number 1 generally identifies the container body; number 2, the external tubular body fitted with helicoidal channels; number 3, the grooved tubular body, concentric to the external body.

Number 4 identifies the cap for holding the product bar 5; number 6, the container closing cap.

Inner tubular body 3 has an extended lower end with a grooved zone 7, advantageously of a larger diameter, designed to facilitate the handling of said inner tubular body 3 when rotated for axial movement of cap 4 holding the product bar 5.

Number 6 identifies the closing cap, with its open end 8 and closed opposite end 9. Number 10 identifies the annular projection or nerve projecting from the inner wall of the cap; number 11 is the peripheric nerve projecting along the container's inner part. Number 12 identifies the gap between the container body and the walls of cap 6. Number 13 identifies the attachment channel in cap 6; number 14 is the coinciding nerve or projection which, in this case, is formed in the container body.

PREFERRED EMBODIMENT OF THE INVENTION

These drawings reveal that the improved mechanical container 1 proposed by the invention comprises, as these containers normally do, two concentric and mutually adapted cylindrical/ tubular elements 2, 3 inside of which is slidingly lodged a cap 4 that secures the product bar 5, said cap 4 being capable of alternate rectilinear motions drawing the lipstick 5 partially out of the container and back inside. The assembly thus forms a container body 1 fitted with appropriate mechanical means for alternatively operating the cap 4 holding the product bar 5.

According to the invention, attachment means are provided between the container body 1 and the surrounding closing cap 6, the lipstick bar 5 remaining totally hidden and protected inside the container.

The upper part of body 1 has a zone 7 formed by an extension, advantageously of a larger diameter, of the inner tubular element or reed 2 which, when rotated manually in either direction, draws the lipstick bar 5 outward or inward.

Above said zone 7, the tubular body 2 shows an increased thickness or nerve 11 which extends, uninterruptedly or otherwise, along the periphery of body 2, said nerve 11 acting as a retainer for the cap 6 when the latter is fitted and surrounds the upper part of container 1.

Cap 6, which provides an upper cover for the container 1, is formed by a cylindrical tubular body with a closed upper end 9 and open opposite end 8 and reveals, along its inner plane and near the edge of its open end 8, an increased thickness or nerve with a curvilinear section 10 extending, either uninterruptedly or otherwise, along the inner wall of cap 6 and forming a ring 10, thereby providing three main functions: the first function of the cap's increased thickness or annular nerve 10 consists in cooperating with the peripheric nerve 11 projecting from the body of the container 1 in order to establish and secure, between the nerves 10 and 11, a perfect retainer for the cap 6 over the container body 1; the second function consists in forming an annular line having minimum contact with the external wall of the container, thus achieving a smooth sliding movement of the cap 6 over the container body 1; the third function consists in reinforcing the lower open edge 8 of cap 6 to prevent its tearing.

The enlarged complementary detail in figure 2 reveals that the annular nerve 10 in cap 6, when applied over the container 1, forms a small gap 12 between the two bodies in such a manner that the sliding of the cap 6 over the container 1 is implemented by contacting only the fine annular line offered by the continuous or discontinuous nerve 10 in the cap 6. An extremely smooth sliding action of cap 6 is achieved via this major improvement along the whole length of the container 1 section forming the lipstick driving mechanism.

Upon inserting the cap by simple manual pressure, annular nerve 10 contacts annular nerve 11 on the container body 1, undergoes a slight resilient radial deformation and surpasses said container nerve 11, thereby retaining and stabilizing the cap in the container's closed position.

The container body cap is removed manually by sliding the cap nerve 10 over nerve 11 on the container 1, whereby it resiliently deforms and ceases the blocking to allow movement of the cap 6 to open the container.

The invention also foresees the possibility that cap 6, on reaching the end of its run, opposes its nerve 10 to a coinciding channel 14 in the periphery of the container, becomes inserted in it and remains lodged in the closed position of container 1. This blocking is established because the cap's projection or annular nerve 10, upon pressing on the container body, develops a central perimetric pressure; when said annular projection 10 coincides with the channel 11, said pressure pushes it into the channel and stabilizes the cap in the closed position. The preceding description indicates that the annular nerve 10 is formed along the inner wall of cap 6 and the fitting channel or groove 11 is formed in the container body, as shown in Figure 3 of the drawings. This type of attachment is not the only one allowed, since the attachment can equally be implemented by forming the projection or nerve 14 on the body of the container and forming the attachment channel 13 receiving said nerve 14 along the inner wall of cap 6, as shown in Figure 2

in its enlarged detail.

After conveniently describing the objects of the invention, it should be stated that detail modifications may be introduced in the improved container proposed provided the essential concept of the invention is not altered.

Claims

1. Improved mechanical container for bar-shaped products, of the type comprising, in combination, a cap (4) for holding a product in the shape of a bar, optionally a lipstick (5), which slides axially along a rectilinear alternate movement on a reed or grooved tubular cylindrical body (2) lodged inside a second tubular element (3) fitted in its inner face with helicoidal channels inside of which slide radial stubs projecting from the cap (4) and which penetrate the longitudinal grooves of the inner tubular body (2), which body presents a grooved lower end extension designed to facilitate its manual handling, said container being characteristic in that the external body provided with the helicoidal grooves (3) has an external lower zone fitted with a peripheric projection or nerve (11) with a curvilinear section which extends, uninterruptedly or otherwise, throughout the periphery of said body (3) to act as an attachment means for holding the closing cap (6) in the container's closed position.
2. Improved mechanical container for bar-shaped products, according to claim 1, characteristic in that the container closing cap (6) has an increased thickness or nerve (10) along the inner side of its open end edge which extends, uninterruptedly or otherwise, and substantially reinforces the edge of the cap.
3. Improved mechanical container for bar-shaped products, according to claims 1 and 2, characteristic in that the annular nerve (10) for reinforcing the cap (6) has a curvilinear section and constitutes an inner annular reinforcement leaning directly over the external wall of the tubular body, which body is fitted with helicoidal depressions (3) forming a small gap or chamber between said body and said cap, thereby reducing the friction between the body of the container (1) and the tubular cap (6) to a minimum.
4. Improved mechanical container for bar-shaped products, according to claims 1 and 2, characteristic in that the annular reinforcing nerve (10) projecting over the inner wall of the cap (6) forms a supporting ring for smooth sliding action over the external wall of the body of container (1).
5. Improved mechanical container for bar-shaped

products, according to claims 1 and 4, characteristic in that, upon placing the cap (6) on the body, the cap's inner nerve (10) suffers a slight resilient deformation on surpassing the annular nerve (11) which surrounds the lower zone of the body of the container (1), becoming retained by said nerve (11) and thus securing the cap over the container in its closed position.

5

6. Improved mechanical container for bar-shaped products, according to claim 1, characteristic in that the external tubular body (3) internally fitted with helicoidal guide channels adjacent its lower end has a peripheric channel (14) for receiving a coinciding annular projection (13) that emerges from the inner wall of the closing cap (6).

10

15

7. Improved mechanical container for bar-shaped products, according to claim 1, characteristic in that the projection (10) emerging from the inner wall of the closing cap (6) extends, uninterruptedly or otherwise, along the inside of cap (6) and provides an annular supporting nerve for smooth sliding movement over the container (1) body, developing a central perimetric pressure over the body so that, upon facing the coinciding channel (14) formed in the container body, penetrates the channel and stabilizes the closed position of the container.

20

25

8. Improved mechanical container for bar-shaped products, according to claims 1 and 2, characteristic in that the container (1) body presents, near its lower end, an increased diameter which forms a projection of a curvilinear section (11) that extends, uninterruptedly or otherwise, throughout its periphery and onto which projection fits the closure cap, said cap being provided near its open end (8) with an inner channel (13) designed to stabilize the closed position of the container.

30

35

40

45

50

55

