

(19) World Intellectual Property Organization
International Bureau



(43) International Publication Date
26 May 2011 (26.05.2011)

(10) International Publication Number
WO 2011/062898 A1

- (51) International Patent Classification:
G03B 21/50 (2006.01)
- (21) International Application Number:
PCT/US2010/056837
- (22) International Filing Date:
16 November 2010 (16.11.2010)
- (25) Filing Language: English
- (26) Publication Language: English
- (30) Priority Data:
12/622,741 20 November 2009 (20.11.2009) US
- (71) Applicant (for all designated States except US): **FISHCO INNOVATION LLC** [US/US]; 240 Broadway, #306, Brooklyn, NY 11211 (US).
- (72) Inventor; and
(75) Inventor/Applicant (for US only): **FISCHER, Troy** [US/US]; 321 West 55th Street, #24, New York, NY 10019 (US).
- (74) Agent: **BITTMAN, Scott, L.**; Crowell & Moring LLP, Intellectual Property Department, 1001 Pennsylvania Ave., NW, Washington, DC 20004 (US).

- (81) Designated States (unless otherwise indicated, for every kind of national protection available): AE, AG, AL, AM, AO, AT, AU, AZ, BA, BB, BG, BH, BR, BW, BY, BZ, CA, CH, CL, CN, CO, CR, CU, CZ, DE, DK, DM, DO, DZ, EC, EE, EG, ES, FI, GB, GD, GE, GH, GM, GT, HN, HR, HU, ID, IL, IN, IS, JP, KE, KG, KM, KN, KP, KR, KZ, LA, LC, LK, LR, LS, LT, LU, LY, MA, MD, ME, MG, MK, MN, MW, MX, MY, MZ, NA, NG, NI, NO, NZ, OM, PE, PG, PH, PL, PT, RO, RS, RU, SC, SD, SE, SG, SK, SL, SM, ST, SV, SY, TH, TJ, TM, TN, TR, TT, TZ, UA, UG, US, UZ, VC, VN, ZA, ZM, ZW.
- (84) Designated States (unless otherwise indicated, for every kind of regional protection available): ARIPO (BW, GH, GM, KE, LR, LS, MW, MZ, NA, SD, SL, SZ, TZ, UG, ZM, ZW), Eurasian (AM, AZ, BY, KG, KZ, MD, RU, TJ, TM), European (AL, AT, BE, BG, CH, CY, CZ, DE, DK, EE, ES, FI, FR, GB, GR, HR, HU, IE, IS, IT, LT, LU, LV, MC, MK, MT, NL, NO, PL, PT, RO, RS, SE, SI, SK, SM, TR), OAPI (BF, BJ, CF, CG, CI, CM, GA, GN, GQ, GW, ML, MR, NE, SN, TD, TG).

Published:
— with international search report (Art. 21(3))

(54) Title: PROJECTOR SYSTEM FOR ANIMATION OF IMAGE CELLS

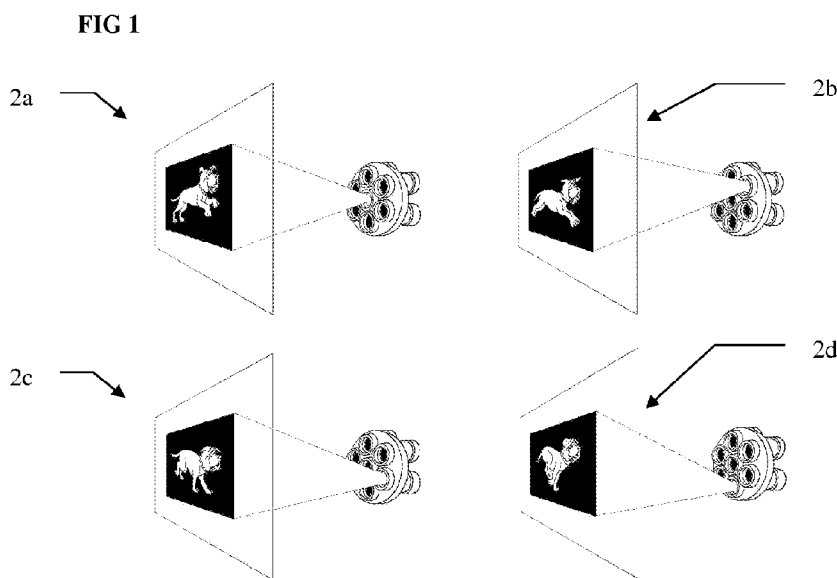

(57) Abstract: An image animation system having a plurality of individual image projectors focused onto a single focal area on a projection surface or medium. Angled optics, or a prism, may be used to direct the projections onto the single focal area. Individual still images are projected in a sequence to create a projected motion animation.

WO 2011/062898 A1

PROJECTOR SYSTEM FOR ANIMATION OF IMAGE CELLS

The present invention relates to animation system displays with a minimum of moving parts. More particularly, this invention provides for a plurality of individual slide projectors that project light through individual slides sequentially onto a surface or medium to produce an animation of a moving image. The resultant animation may be used in numerous applications, such as, animated nightlights, animated facial features inside toy figures, baby crib image projector, or in a toy vehicle that flashes images by rolling forward or backward.

Background

Devices that project moving images have typically required the use of motors to move a film or image wheel. Those systems have tended to be noisy, bulky in design, and costly to produce due to the many moving parts required.

The power required for such motorized systems to operate has also limited performance in many battery-operated applications. For many applications, devices have used LCD screens, LCD projectors, and other electronic displays, which were often very costly.

Such prior art systems do not teach or suggest the use of individual light sources and whole-image projecting lens systems in an image animation display. Exemplary prior art

systems include those discussed in the following patents and published patent applications.

U.S. Patent No. 3,573,785 (Miller) discloses a stroboscopic display in which images are placed on the face of a drum and selectively illuminated by lamps.

U.S. Patent No. 3,973,840 (Jacobs et al.) discloses a mannequin that simulates speech by rear projecting footage of a talking human face onto the inner surface of the mannequin's face.

U.S. Patent No. 5,300,966 (Uehira et al.) discloses the use of a combination of liquid crystal light valves and mirrors in order to compose light beams as image parts into a composite moving image.

U.S. Patent No. 4,104,625 (Bristow et al.) discloses using a plurality of cell units which each have a film negative which may include a full or partial image and, by illuminating cell units in a particular order, animated movement of facial features can be simulated. The device uses a flash tube to illuminate the cells, but use of a shutter, both mechanical and electrical, is disclosed.

U.S. Patent No. 5,426,460 (Erving et al.) discloses an method of animating a facial image. The lips of a still image are replaced by an idealized image, which is synched to a voice transmission.

U.S. Patent No. 5,902,030 (Blanchard) discloses a projection display system that uses two off-axis projectors that project onto a curved surface in order to seamlessly compose the two projected images into a whole image.

5 U.S. Patent Publication No. 2003/0133080 (Ogawa et al.) discloses the use of LED-illumination in a digital micro-mirror device projector. Multiple fly-eye lenses are utilized, one for each of the primary colors.

10 U.S. Patent No. 6,481,849 (Martin et al.) teaches the use of multiple image sources, which "display sequential images of an object in a time-multiplexed manner". The multiple image sources are projected adjacent one another and a diffuser is used to "smear" the seams between adjacent views.

15 U.S. Patent No. 6,513,938 (Kubota et al.) discloses a multi-display device that uses a plurality of projectors that each project a distinct portion of an image.

20 U.S. Patent No. 7,273,280 (Smoot et al.) teaches the use of multiple projectors which present background and foreground images "on demand" as the projector responds to electrical signal input from the user.

U.S. Patent No. 7,396,136 (Kim et al.) discloses an illumination unit to replace high-pressure mercury lamps which employs a plurality of LED's in modules which can sequentially emit red, green and blue columns of light.

U.S. Patent Publication No. 2008/0129963 (Hohl) discloses an image animation apparatus that uses a rotating motor driven image drum for selected strobing of animation frames.

Such prior systems have been mechanically and electronically complex. As a result, they do not provide low cost, compact and reliable moving image display systems that can be used in, for example, toys, novelties, night lights.

Summary of the Invention

The present invention relates to an image animation system having a plurality of individual image projectors focused onto a single area of a projection surface or medium. The invention utilizes multiple light sources, that each may illuminate individual still images in an electrically or mechanically dictated sequence to create an animation. Low-energy light sources, such as LEDs, may be used as the light source for the animation. Further, the image sequence may be linked to a sound card and a speaker so that sound can be integrated with the animation.

In one embodiment, individual projectors may each be angled towards a focal area on a projection medium. In other embodiments, angled optics, or prisms, may be used to direct the light from the projectors towards the focal area on the projection medium.

The projector system may be implemented in an embodiment where individual projectors, each contain a single image

frame. Alternatively, a single slide containing a plurality of images may be used. Further, a master slide transparency wheel containing multiple sets of animations can allow for manipulation among sets of images.

5 The present invention has many potential applications including use in, for example, front or reverse projection screens for toys, animated nightlights, animated background for any environment, animated face inside toy figures, baby crib image projector, or in a toy vehicle that flashes images
10 by rolling forward or backward.

Brief Description of Drawings

FIG. 1 illustrates the projection of individual frames using an embodiment of a projection system according to the present invention.

15 FIG. 2 depicts a block diagram of an embodiment of the present invention employing a microprocessor.

FIG. 3 depicts a block diagram of an embodiment of the present invention employing a rotary switch.

20 FIG. 4 depicts a block diagram of an embodiment of the present invention employing a sound card.

FIG. 5 depicts a cutaway view of an individual projector according to an embodiment of the present invention.

FIG. 6 depicts an isometric drawing of an embodiment of the present invention.

FIG. 7 depicts a block diagram illustrating light paths of an embodiment of the present invention.

FIG. 8 depicts a single image transparency according to an embodiment of the present invention.

5 FIG. 9 depicts a block diagram illustrating light paths of an embodiment of the present invention using angled prisms.

FIG. 10 depicts a block diagram illustrating light paths of an embodiment of the present invention using an integrated prism.

10 FIG. 11 depicts an integrated transparency holder according to an embodiment of the present invention.

FIG. 12a depicts a top view of an embodiment of the present invention showing an integrated projection system containing individual prisms.

15 FIG. 12b depicts a cross section of an embodiment of the present invention depicted in FIG 12a.

FIG. 12c depicts a top view of an embodiment of the present invention showing an integrated projection system containing an integrated prism.

20 FIG. 12d depicts a cross section of an embodiment of the present invention depicted in FIG 12c.

FIG. 13a depicts an exploded view of the integrated projection system shown in FIG 12a and FIG 12b.

25 FIG. 13b depicts an exploded view of the integrated projection system shown in FIG 12c and FIG 12d.

FIG. 14 depicts an embodiment of the present invention showing several flat integrated transparency holders aligned in a master slide transparency wheel.

FIG. 15 depicts an alternative view of the embodiment of the present invention showing the master slide transparency wheel.

FIG. 16 depicts a side view of an embodiment of present invention showing the master slide transparency wheel.

Detailed Description of Exemplary Embodiments

Figure 1 illustrates a sequence of images projected onto a surface (2a, 2b, 2c, 2d) according to an embodiment of the present invention. The particular exemplary embodiment illustrates four projected images that, when displayed in sequence, results in the animation of a dog running.

A block diagram of one embodiment of the present invention is shown in Figure 2, illustrating how the basic animation sequence can be achieved. Light source outputs 6a - 6g display projected frames 4a-4g, respectively. The microprocessor 8, dictates the sequence upon which the light source outputs 6a-6g are enabled to display the output projected frames 4a-4g. To achieve an animation, only of one light source outputs 6a-6g is enabled at a time. To achieve an animation sequence, the microprocessor may enable the sequencing of animations in order from 4a through 4g. The microprocessor may run on a continuous loop in sequence(e.g,

4a, 4b, 4c, 4d, 4f, 4g) to show, for example, a character running, or oscillate in a back and forth sequence (e.g., 4a, 4b, 4c, 4d, 4c, 4b, 4a) to show, for example, a character jumping up and down. The microprocessor 8 may be, for
5 example, a commodity 8-bit microcontroller, such as a MicroChip Pic 18F252 or an Ubicom SX-28a. The system may be powered by a DC power source 10.

Figure 3 illustrates an embodiment illustrating that, instead of a microprocessor, a manual switch, such as a rotary
10 switch 12, may be used to cause the animation sequence. The rotary switch 12 provides for manual switching among light source outputs 6a-6g that produce projected frame 4a-4g. The rotary switch 12, may have a plurality of contacts. When it is turned, the switch may make contact with one LED or light
15 source at a time. When turned continually, each revolution of the switch actuator completes a cycle. The light source can be wired to power the LEDs in a predetermined sequence to create the desired animation. The frames can be looped in sequence or oscillate in a back and forth sequence depending on how the
20 switch is wired to address the light sources. Such a system may be used in, for example, a toy vehicle. In that situation, rolling the car would provide the switching for the animation. The speed of the toy vehicle would dictate the speed of the animation, as the animation would be displayed more quickly

based on the car moving more quickly, due to the mechanical nature of the switching.

Figure 4 depicts an embodiment showing that sound can be linked to the animation. The microprocessor 8 is connected to sound chip 9 and output speaker 11. The sound chip 9 may be, for example, a commodity embedded digital audio sample playback system, such as a WinBond ISD-2560.

In this embodiment, facial animation projected frames 5a-5g or visual visemes, for example, may be used. Each viseme slide image projected by its light source may correspond to a vocal sound or phoneme. When a phrase is activated by the user, the series of phonemes that are produced through speech are timed to be heard at the same time that the corresponding viseme is seen. The result may be a simulation of a talking face that makes vocal gestures timed with speech sounds. One possible implementation for this embodiment would be for the animation of facial features within, for example, a toy action figure.

A cutaway view of an individual light source output 6 is shown in Figure 5. The light source 18 may be an LED, incandescent light bulb, or other source. A slide transparency (reticle) 17 may contain a graphic image that may show one phase of an animation. Lens holder 14 holds lens 15 in alignment.

Figure 6 represents an isometric drawing showing seven light output sources 6 grouped together into one integrated projection system 20. A different number of light output sources 6 may alternatively be used an integrated projection system.

Figure 7 shows a view demonstrating the alignment of the plurality of light output sources 6 (shown as 6a, 6b, and 6c) in the integrated projection system 20. By positioning the outer light output sources (such as 6a and 6c in the demonstrated embodiment) at angles, the light paths, shown as 26a, 26b, and 26c, can each be projected towards the same area on the projected surface medium 24. The alignment positioning directly correlates to the intended distance of the medium 24 from the integrated projection system 20. The medium 24 may be a screen or wall, or any number of surfaces including, for example, smoke, ice, water, etc.

Figure 8 depicts an exemplary slide transparency 17 for a single image as may be used in individual light source output 6.

Figure 9 presents an first alternative embodiment of an integrated projection system, depicted generally as 32, containing individual light source outputs 31a, 31b, and 31c. This first alternative embodiment uses angled prisms 34a to guide the light paths, depicted as 35a, 35b, and 35c, of the outer light source outputs 31a and 31c, so that all light

paths 35a, 35b, and 35c are projected onto the same location on medium 24. Alternatively, as shown in Figure 10 an integrated prism 37 may be used that directs the light paths for each individual light source output towards the same location on the medium 24.

Figure 11 depicts an embodiment showing an integrated transparency holder 40 that holds an integrated common slide 41 (depicted in Figures 12b, 12d, 13a, 13b). The integrated common slide is a single slide that contains a plurality of images that each represent individual frames for an animation. By utilizing the integrated transparency holder, it may be possible to substitute all images for an animation out at one time. Additionally, there is no need to individually assemble slides within the individual light sources.

Shown in Figures 12a and 12b are a top view and cross section of an embodiment of a parallel integrated projection system 42 utilizing an integrated transparency holder 40 that holds an integrated common slide 41. Light sources are arranged adjacent to individual images on the integrated common slide. The system may use angled prisms 34a or, as shown in Figures 12c and 12d, an integrated prism 37 to align the light paths to the same focal area.

Figure 13a represents an exploded cross-section view of the embodiment shown in Figure 12b. Screws 44, attach retaining bracket 46 to the angled prisms 34a and to the lens

housing 62. Optic spacer 58 maintains the proper spacing of the angled prisms 34a. Integrated lens 48, 50 sit within lens holder 60. Light sources 54, which may be LEDs, may sit within the light source housing 66. The integrated
5 transparency holder 40 that holds an integrated common slide sit within the structure. Figure 13b represents an exploded cross-section view of the embodiment shown in Figure 12d, containing an integrated prism 37.

Figures 14, 15, and 16 depict a second alternative
10 embodiment that utilizes a master slide transparency wheel 70. The wheel 70 may contain multiple sets of animations, such as those depicted as 72, 74, 76, and 78. The parallel integrated projection system 42 is aligned with one set of animations at a time, however by rotating the wheel 70, a different
15 animation may be displayed. Switching among animations may be implemented manually, mechanically, or electromechanically.

It is to be understood that the embodiments are merely illustrative of the present invention and that many variations of the above-described embodiments can be devised by one
20 skilled in the art without departing from the scope of the invention. It is therefore intended that all such variations be included within the scope of the following claims and their equivalents.

25

Claims

1. A projection system, comprising:
a plurality of image frames;
a plurality of projection light sources for projecting
5 individual ones of the plurality of image frames onto a
medium, the plurality of projection light sources being in
alignment with the plurality of image frames;
optics for directing the projected image frames onto a
focal area of the medium; and
10 a switching device for enabling the plurality of
projection light sources in a sequence,
wherein the projected image frames are displayed at the
focal area on the medium in accordance with the sequence.
2. A projection system according to claim 1, wherein
15 the plurality of image frames are contained on a single slide.
3. A projection system according to claim 1, wherein
the switching device is a microprocessor.
4. A projection system according to claim 1, wherein
the switching device is a rotary switch.
- 20 5. A projection system according to claim 1, wherein
each of the plurality of projection light sources comprises an
LED.
6. A projection system according to claim 1, further
comprising a sound card and an output speaker for projecting
25 audio to accompany the sequence of projected images.

7. A projection system according to claim 1, further comprising an integrated prism containing the optics.

8. A projection system according to claim 1, further comprising:

5 a master slide transparency wheel comprising a first set of image frames and a second set of image frames,

wherein rotation of the master slide transparency wheel results in a change of alignment of the plurality of projection light sources from the first set of image frames to
10 the second set of image frames.

9. A projection system, comprising:

a plurality of image frames;

a plurality of projection light sources for projecting individual ones of the plurality of image frames onto a
15 medium, the plurality of projection light sources being in alignment with the plurality of image frames, the projected image frames being directed towards a focal area of the medium; and

a switching device for enabling the plurality of
20 projection light sources in a sequence,

wherein the projected image frames are displayed at the focal area on the medium in accordance with the sequence.

10. A projection system according to claim 9, wherein the plurality of image frames are contained on a plurality of
25 slides.

11. A projection system according to claim 9, wherein the switching device is a microprocessor.

12. A projection system according to claim 9, wherein the switching device is a rotary switch.

5 13. A projection system according to claim 9, further comprising:

optics for directing the projections of image frames onto the focal area of the medium.

14. A projection system according to claim 9, wherein
10 each of the light source comprises an LED.

15. A projection system according to claim 9, further comprising a sound card and an output speaker for projecting audio to accompany the sequence of projected images.

16. A method for animation, comprising:
15 projecting a first light source through a first image frame;

directing the projection of the first image frame through optics onto a focal area of a medium;

projecting a second light source through a second image
20 frame after the projection of the first light source has completed; and

directing the projection of the second image frame through optics onto the focal area of the medium.

17. A method for animation, according to claim 16,
25 further comprising:

projecting sound through an output speaker during the projection of the first light source and the projection of the second light source.

18. A method for animation, according to claim 16,
5 wherein the projection of the first light source is in a direction that is parallel to a direction of the projection of the second light source.

19. A method for animation, according to claim 16,
further comprising:

10 projecting a third light source through a third image frame after the projection of the second light source has completed; and

directing the projection of the third image frame through optics onto the focal area of the medium.

15 20. A method for animation, according to claim 19,
further comprising:

projecting a fourth light source through a fourth image frame after the projection of the third light source has completed; and

20 directing the projection of the third image frame through optics onto the focal area of the medium.

21. A projection system, comprising:

a plurality of image frames;

a plurality of projection light sources for projecting
25 one or more of the plurality of image frames onto a medium;

optics for directing the projected image frames onto the medium; and

a switching device for enabling the plurality of projection light sources in a sequence,

5 wherein the projected image frames are displayed on the medium in accordance with the sequence.

22. A projection system according to claim 21, further comprising an integrated prism containing the optics.

23. A projection system according to claim 21, wherein
10 each of the plurality of projection light sources comprises an LED.

FIG 1

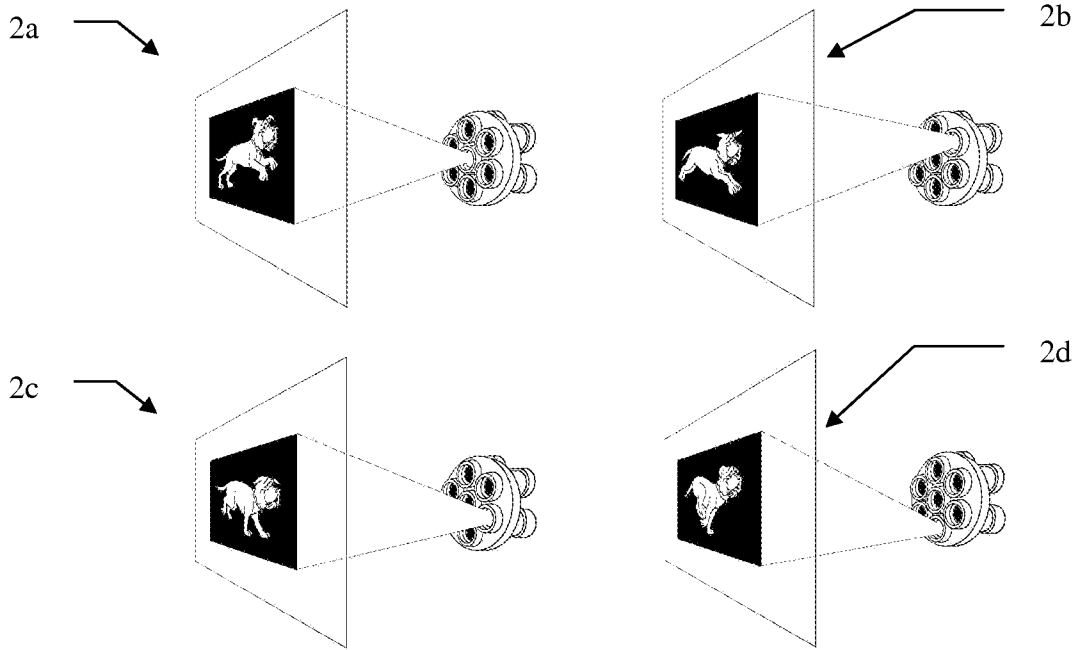

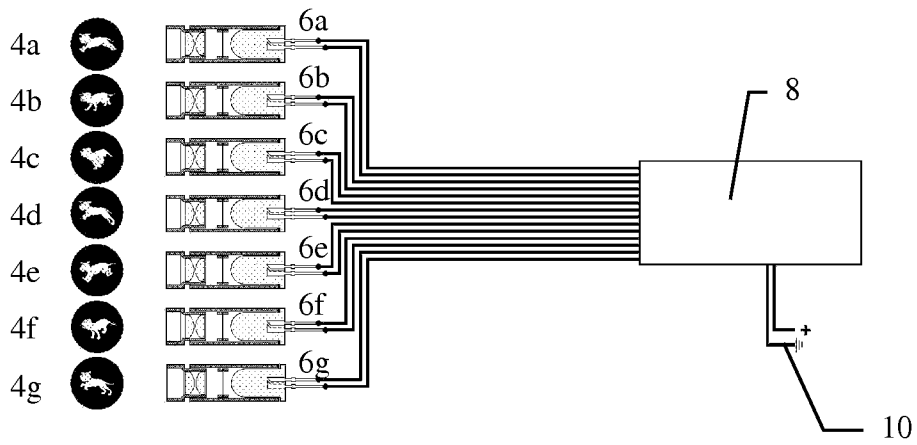

FIG 2

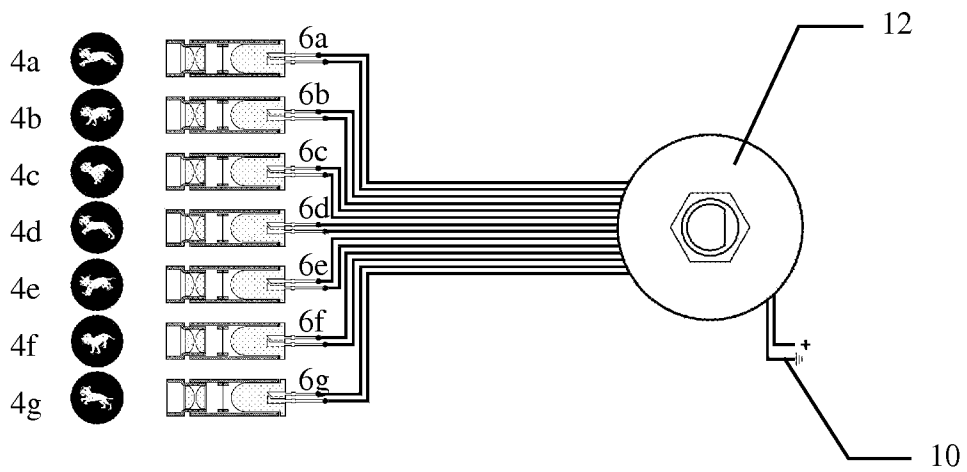

FIG 3

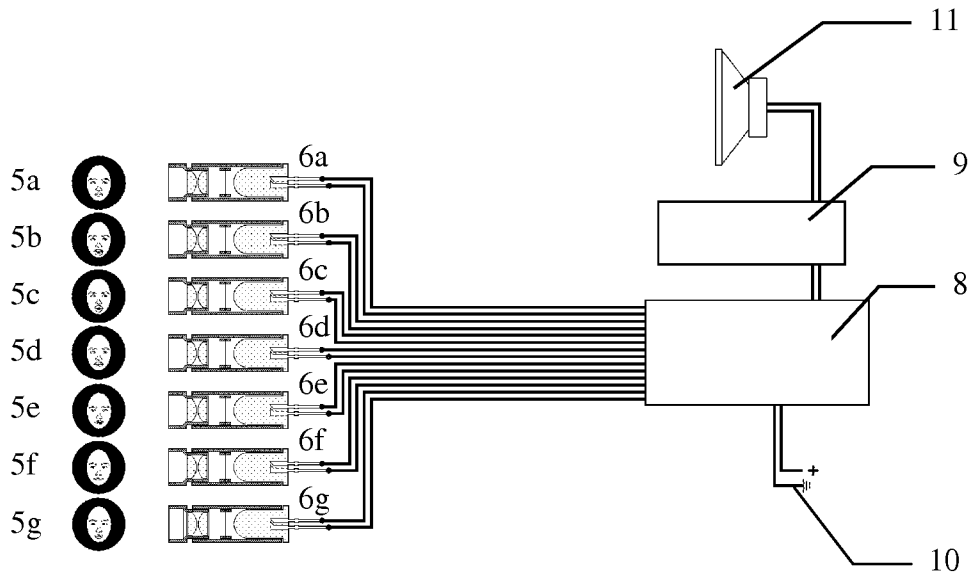

FIG 4

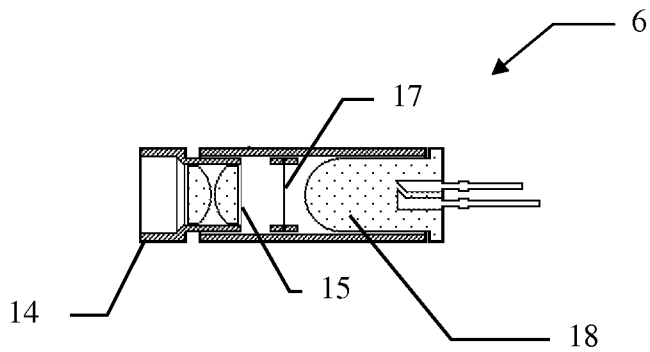

FIG 5

FIG 6

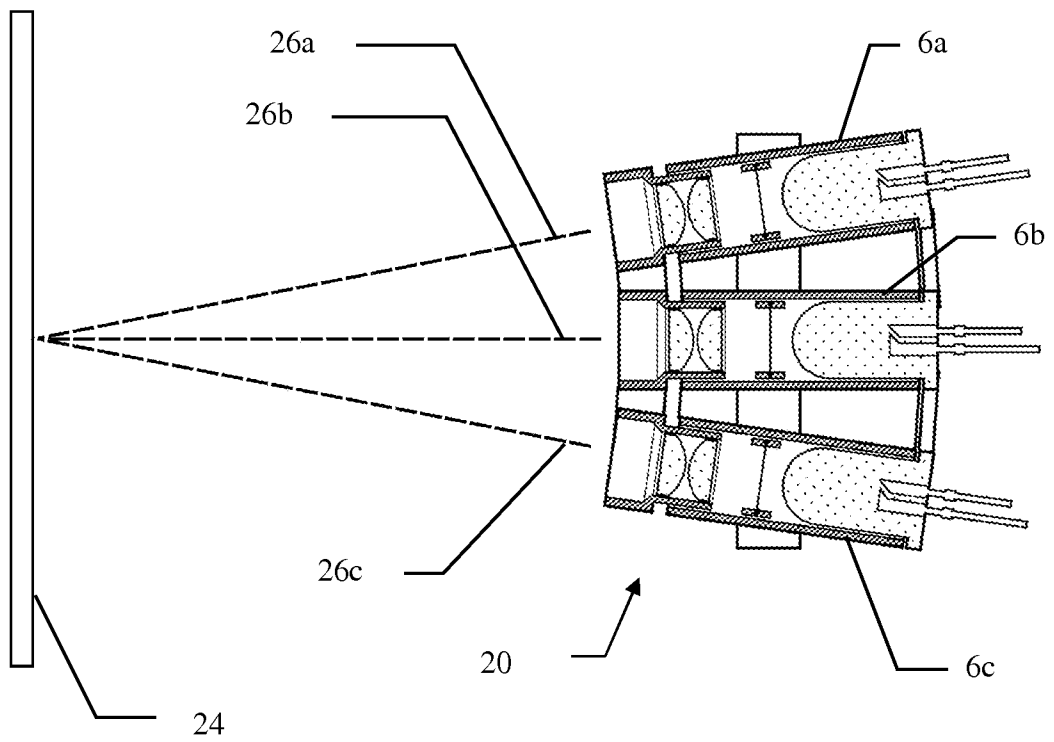
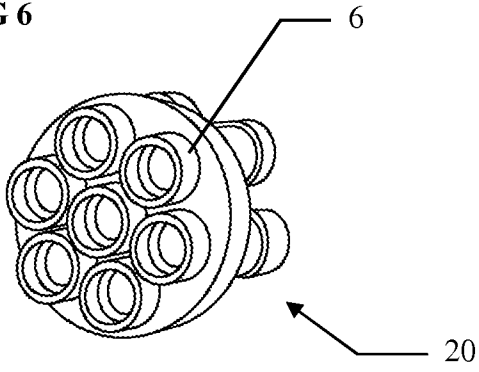

FIG 7

FIG 8

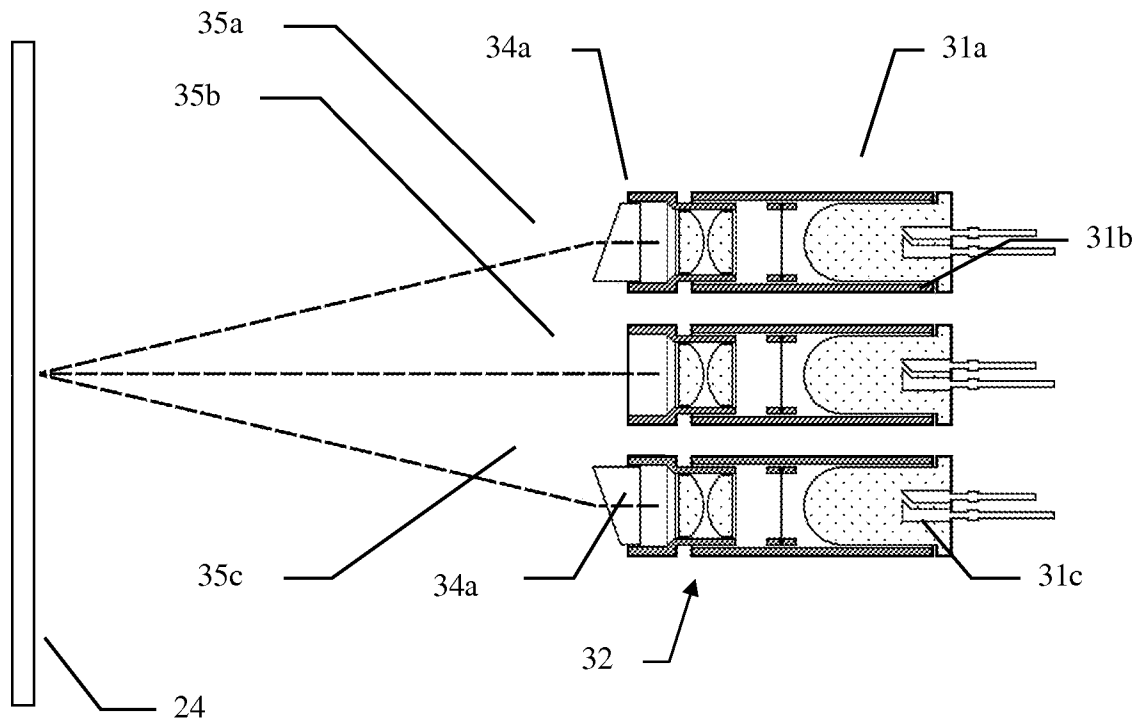
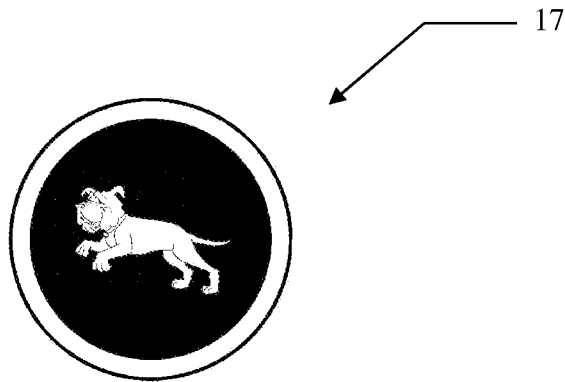

FIG 9

FIG 10

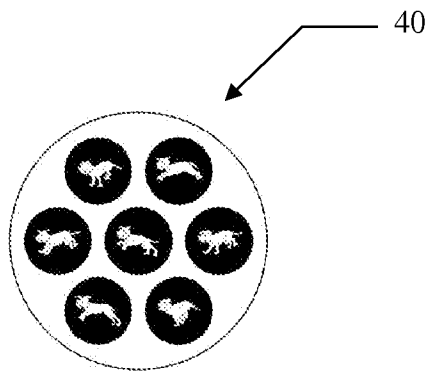
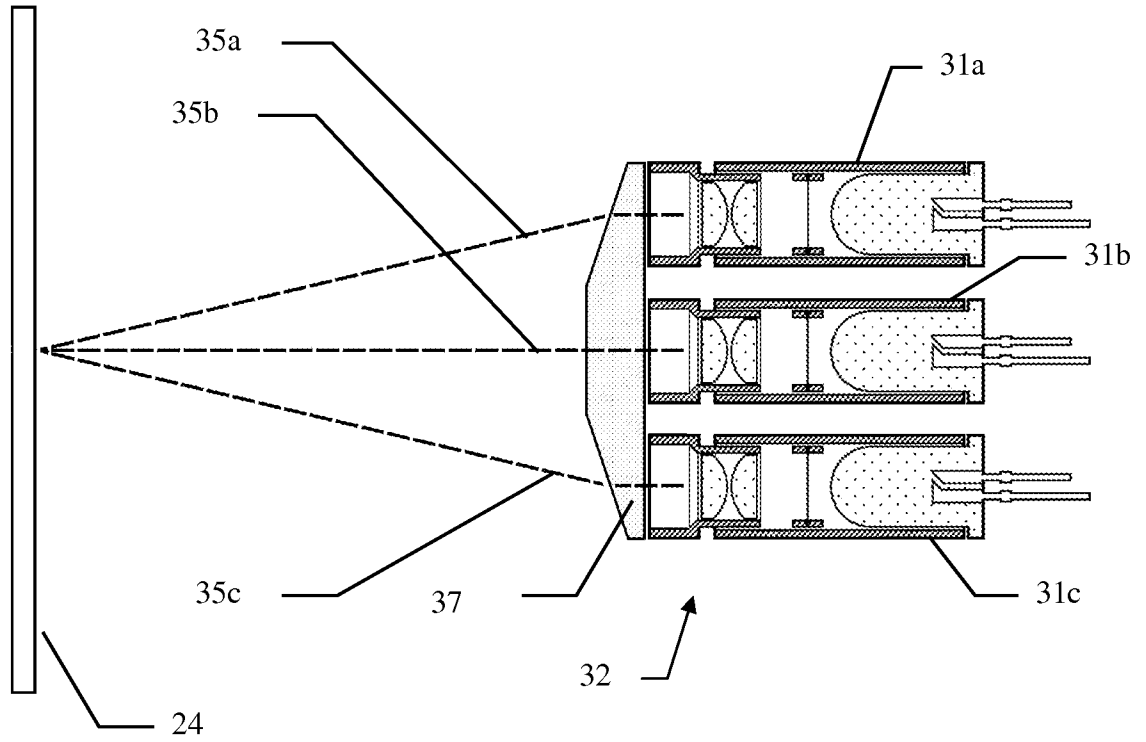

FIG 11

FIG 12a

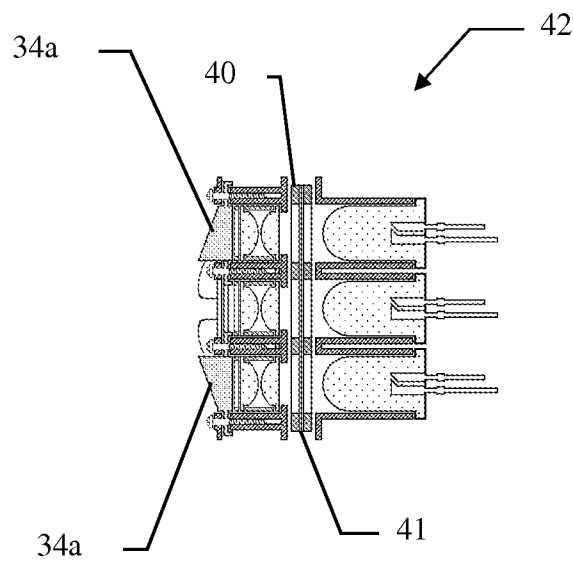
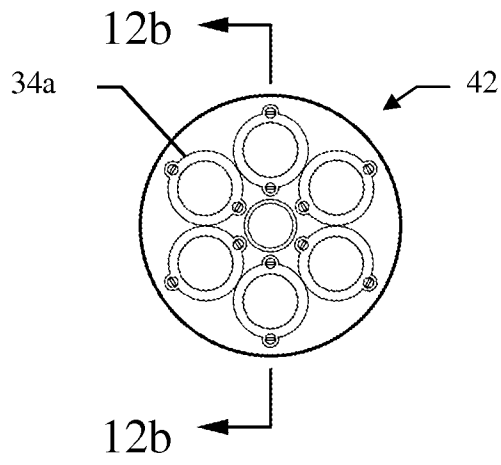

FIG 12b

FIG 12c

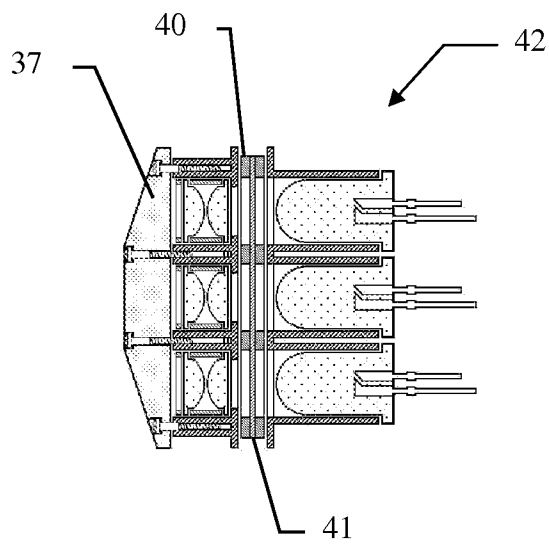
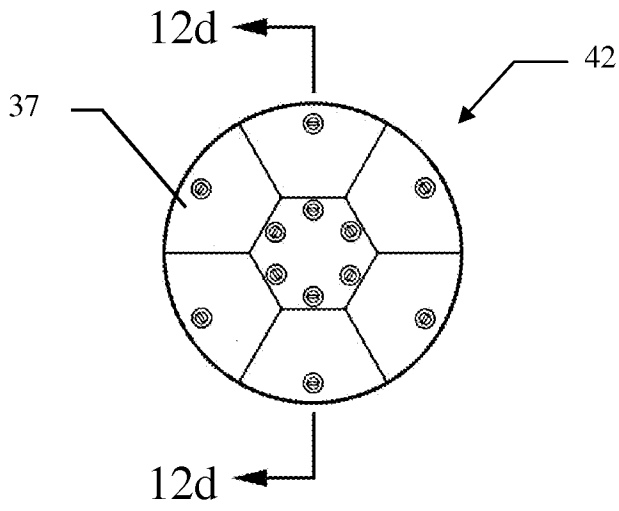

FIG 12d

FIG 13a

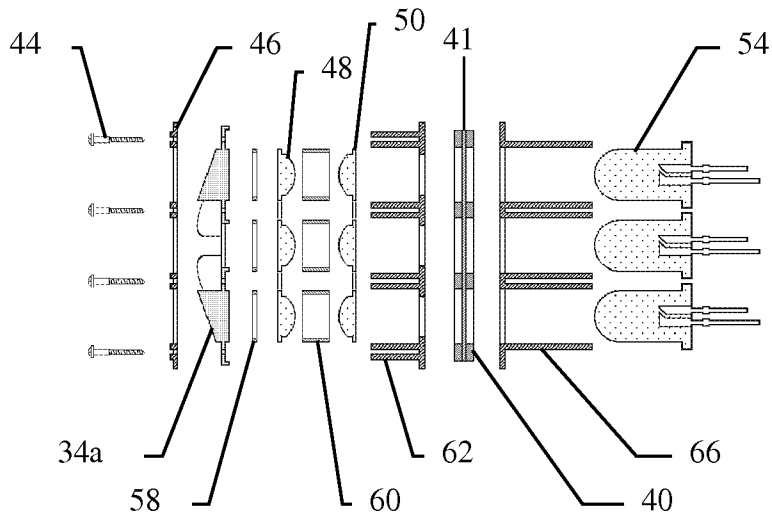

FIG 13b

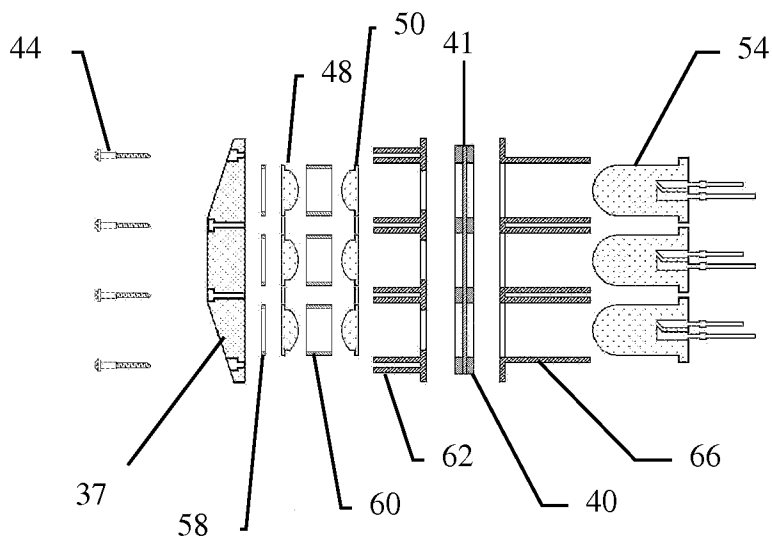

FIG 14

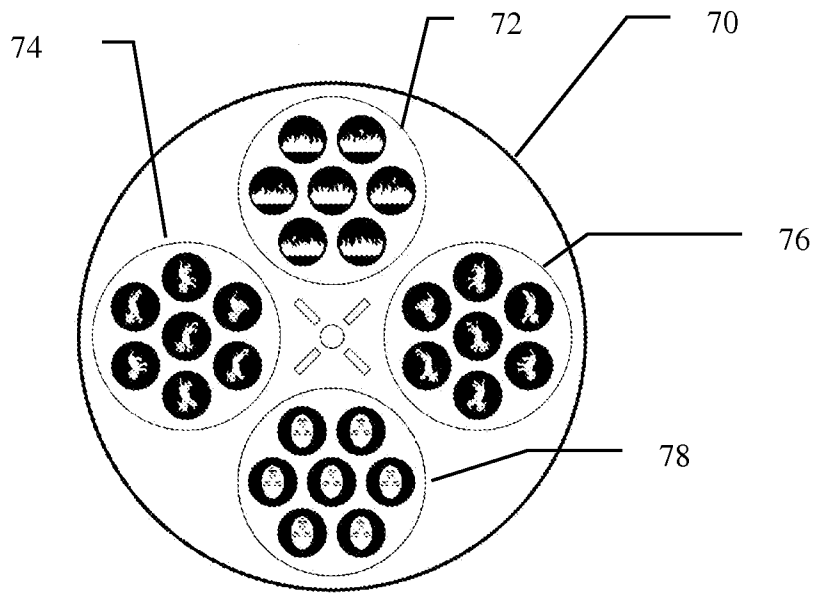

FIG 15

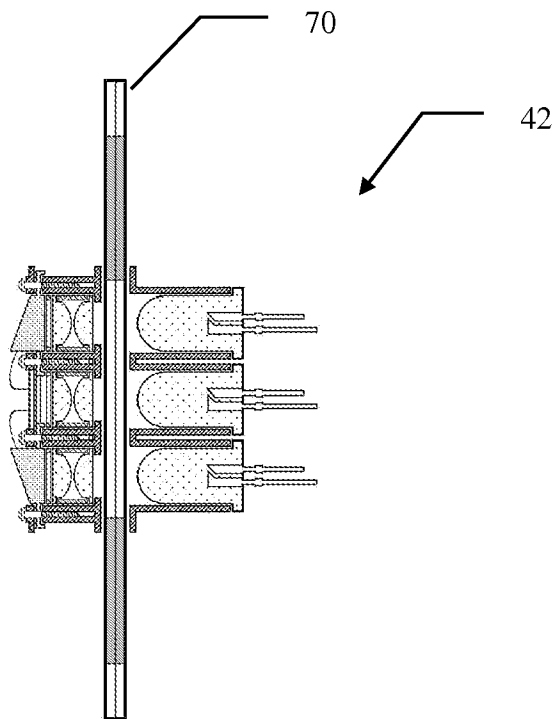
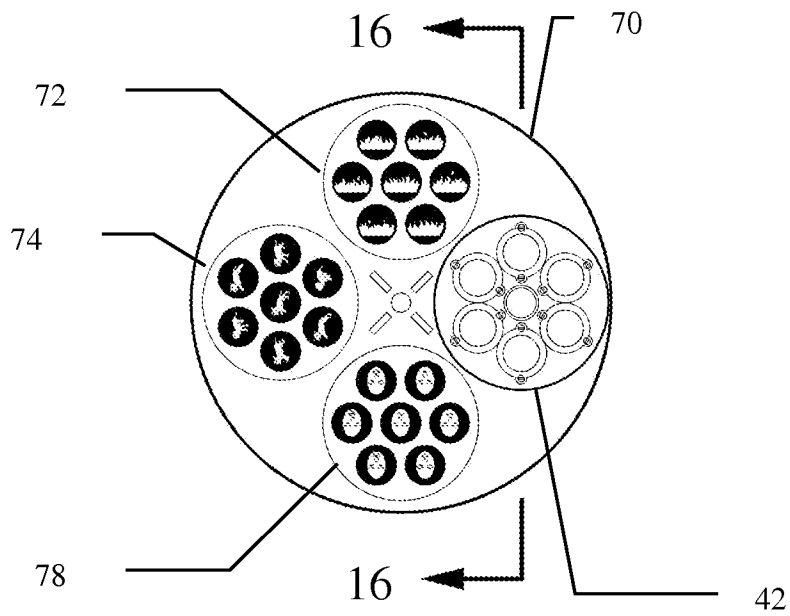

FIG 16

INTERNATIONAL SEARCH REPORT

International application No.

PCT/US2010/056837

A. CLASSIFICATION OF SUBJECT MATTER

IPC(8) - G03B 21/50 (2011.01)

USPC - 353/30

According to International Patent Classification (IPC) or to both national classification and IPC

B. FIELDS SEARCHED

Minimum documentation searched (classification system followed by classification symbols)

IPC(8) - G03B 21/20; G03B 21/50; H04N 5/74 (2011.01)

USPC - 340/318; 353/30, 94

Documentation searched other than minimum documentation to the extent that such documents are included in the fields searched

Electronic data base consulted during the international search (name of data base and, where practicable, search terms used)

PatBase, Google Patents, Google Scholar

C. DOCUMENTS CONSIDERED TO BE RELEVANT

Category*	Citation of document, with indication, where appropriate, of the relevant passages	Relevant to claim No.
Y	US 2008/0129963 A1 (HOHL) 05 June 2008 (05.06.2008) entire document	1-23
Y	US 2007/0195294 A1 (WILLEY et al) 23 August 2007 (23.08.2007) entire document	1-15, 21-23
Y	US 5,847,748 A (LAUGHLIN) 08 December 1998 (08.12.1998) entire document	6, 15
Y	US 5,541,680 A (FROMM) 30 July 1996 (30.07.1996) entire document	10
Y	US 7,273,280 B2 (SMOOT et al) 25 September 2007 (25.09.2007) entire document	16-20
A	US 2004/0183901 (BELLIVEAU) 23 September 2004 (23.09.2004) entire document	1-23

 Further documents are listed in the continuation of Box C.

* Special categories of cited documents:

"A" document defining the general state of the art which is not considered to be of particular relevance

"E" earlier application or patent but published on or after the international filing date

"L" document which may throw doubts on priority claim(s) or which is cited to establish the publication date of another citation or other special reason (as specified)

"O" document referring to an oral disclosure, use, exhibition or other means

"P" document published prior to the international filing date but later than the priority date claimed

"T" later document published after the international filing date or priority date and not in conflict with the application but cited to understand the principle or theory underlying the invention

"X" document of particular relevance; the claimed invention cannot be considered novel or cannot be considered to involve an inventive step when the document is taken alone

"Y" document of particular relevance; the claimed invention cannot be considered to involve an inventive step when the document is combined with one or more other such documents, such combination being obvious to a person skilled in the art

"&" document member of the same patent family

Date of the actual completion of the international search

04 January 2011

Date of mailing of the international search report

14 JAN 2011

Name and mailing address of the ISA/US

Mail Stop PCT, Attn: ISA/US, Commissioner for Patents
P.O. Box 1450, Alexandria, Virginia 22313-1450

Facsimile No. 571-273-3201

Authorized officer:

Blaine R. Copenheaver

PCT Helpdesk: 571-272-4300
PCT OSP: 571-272-7774