

(19) World Intellectual Property Organization
International Bureau



(43) International Publication Date
8 September 2006 (08.09.2006)

PCT

(10) International Publication Number
WO 2006/092700 A1

- (51) International Patent Classification:
A47K 11/02 (2006.01)
- (21) International Application Number:
PCT/IB2006/000411
- (22) International Filing Date:
28 February 2006 (28.02.2006)
- (25) Filing Language: English
- (26) Publication Language: English
- (30) Priority Data:
2005/01758 1 March 2005 (01.03.2005) ZA
- (71) Applicant (for all designated States except US): PLANET WAVES 34 (PTY) LTD [ZA/ZA]; Unit 2 Lagoon Beach Office Park, Lagoon Beach Road, 7441 Milnerton (ZA).
- (72) Inventor; and
(75) Inventor/Applicant (for US only): MOS, Ronald, Edwin [ZA/ZA]; 79 Monte Vista Boulevard, 7460 Monte Vista (ZA).
- (74) Agent: SPOOR & FISHER; Building No. 13, Highgrove Office Park, Oak Avenue, Centurion, PO Box 454, 0001 Pretoria (ZA).
- (81) Designated States (unless otherwise indicated, for every kind of national protection available): AE, AG, AL, AM, AT, AU, AZ, BA, BB, BG, BR, BW, BY, BZ, CA, CH, CN, CO, CR, CU, CZ, DE, DK, DM, DZ, EC, EE, EG, ES, FI, GB, GD, GE, GH, GM, HR, HU, ID, IL, IN, IS, JP, KE, KG, KM, KN, KP, KR, KZ, LC, LK, LR, LS, LT, LU, LV, LY, MA, MD, MG, MK, MN, MW, MX, MZ, NA, NG, NI, NO, NZ, OM, PG, PH, PL, PT, RO, RU, SC, SD, SE, SG, SK, SL, SM, SY, TJ, TM, TN, TR, TT, TZ, UA, UG, US, UZ, VC, VN, YU, ZA, ZM, ZW.
- (84) Designated States (unless otherwise indicated, for every kind of regional protection available): ARIPO (BW, GH, GM, KE, LS, MW, MZ, NA, SD, SL, SZ, TZ, UG, ZM, ZW), Eurasian (AM, AZ, BY, KG, KZ, MD, RU, TJ, TM), European (AT, BE, BG, CH, CY, CZ, DE, DK, EE, ES, FI, FR, GB, GR, HU, IE, IS, IT, LT, LU, LV, MC, NL, PL, PT, RO, SE, SI, SK, TR), OAPI (BF, BJ, CF, CG, CI, CM, GA, GN, GQ, GW, ML, MR, NE, SN, TD, TG).

[Continued on next page]

(54) Title: COMPOSTER

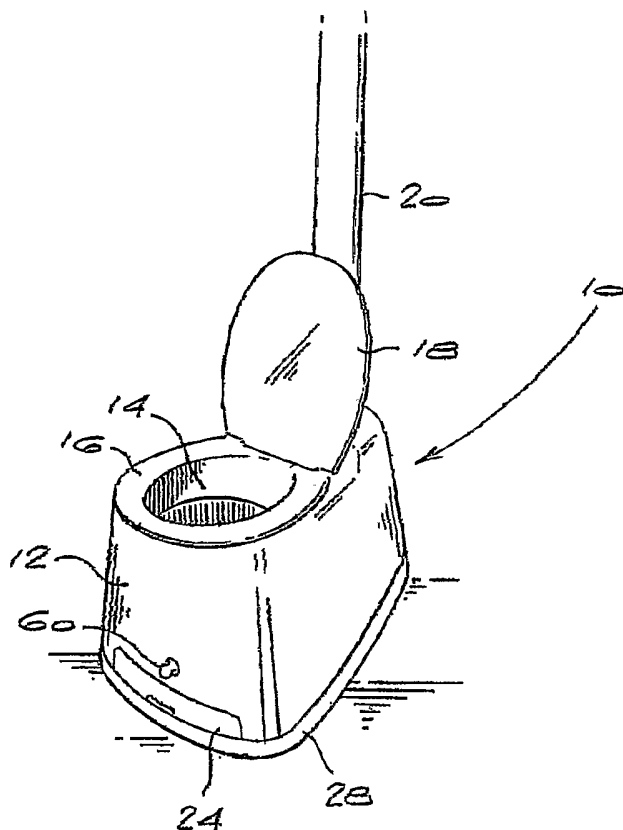

(57) Abstract: The invention concerns a composter (10) having a liquid tank (34) through which liquid can be circulated, the liquid tank being coupled to or containing a liquid heater (70). The composter further includes a perforated housing (36) which is located above the liquid tank and into which perforated housing material to be composted can be discharged, a removable container (30) interposed between the perforated housing and the liquid tank in which receptacle composted material from the perforated housing can be discharged and a cover (12) located over the perforated housing. The composter finally includes a closure (18) in the cover through which closure access can be gained to the perforated housing, so that in use of the composter, air heated by liquid in the liquid tank can pass upwardly through the composter and draw fresh air into the composter to facilitate composting of material in the perforated housing.

WO 2006/092700 A1



Published:

- *with international search report*
- *before the expiration of the time limit for amending the claims and to be republished in the event of receipt of amendments*

For two-letter codes and other abbreviations, refer to the "Guidance Notes on Codes and Abbreviations" appearing at the beginning of each regular issue of the PCT Gazette.

-1-

COMPOSTER

FIELD OF THE INVENTION

This invention relates to a composter. More particularly, but not exclusively, this invention relates to a toilet.

BACKGROUND TO THE INVENTION

Waterless toilets are well known. Generally, they are relatively expensive and include moving parts such as fans and rotating drums.

SUMMARY OF THE INVENTION

According to the invention a composter includes a liquid tank through which liquid can be circulated, the liquid tank being coupled to or containing a liquid heater, a perforated housing located above the liquid tank and into which perforated housing material to be composted can be discharged, a removable container interposed between the perforated housing and the liquid tank in which receptacle composted material from the perforated housing can be discharged, a cover located over the perforated housing, and a closure in the cover through which closure access can be gained to the perforated housing, so that in use of the composter, air heated by liquid in the liquid tank can pass upwardly through the composter and draw fresh air into the composter to facilitate composting of material in the perforated housing.

In the preferred form of the invention the liquid heater is a solar heater, with a closed liquid circuit being formed between the solar heater and the liquid tank. Circulating means is preferably provided between the solar heater

-2-

and the liquid tank. The circulating means may be a pump. The pump may be powered by an electrical solar panel.

The liquid tank may have a capacity of about 10 litres and the total liquid capacity of the solar heater and the liquid tank may be in the order of 30 litres. The solar heater may be about 1 m² in size. Suitable anti-freeze may be added to the water to reduce the freezing temperature of the water to prevent the water from freezing and damaging the liquid tank, the solar heater and associated piping.

Insulating means may be provided below the liquid tank. In one form of the invention the insulating means is a layer of closed-cell rubber foam.

The composter is preferably supported on a base which may itself be made of an insulating material. In one form of the invention the base is made of solid rubber.

The perforated housing is preferably supported on legs and has perforated sidewalls, an open top, and a grid located over an open bottom. The grid may be formed by a plurality of spaced elongate members located at their opposite ends in apertures in opposed sidewalls of the perforated housing. The elongate members may be pipes. Preferably they are 25 mm pipes.

A rake may be provided for raking material in the perforated housing. Preferably tines of the rake locate between the elongate members of the grid, and the handle of the rake projects through the perforated housing and the cover, so that the rake can be manipulated from the outside of the cover to dislodge material caught between the elongate members of the grid. The rake may also include blades extending upwardly from its head for aerating the manure and shredding paper.

In the preferred form of the invention the composter is a waterless toilet. The waterless toilet preferably includes a chimney connected to the cover to facilitate a draft through the composter.

The waterless toilet preferably has a toilet seat supported on the cover, and a closure in the form of a toilet seat cover.

The removable container may be in the form of a drawer. The drawer is preferably narrower than the perforated housing so that in use liquid in the form of urine can be discharged through apertures in the sidewalls of the perforated housing onto the liquid tank without entering the drawer. The drawer preferably contains some perforations through which any liquid entering the drawer can be discharged.

The liquid tank may have circumferentially upwardly extending sidewalls to form a tray within which urine can collect to be heated by hot liquid in the liquid tank and then evaporated from the tray. The liquid circulated through the liquid tank is preferably water.

According to another aspect of the invention a kit for a composter includes liquid tank, perforated housing, removable container, and cover as described above.

The composter may be a waterless toilet, in which event, the toilet preferably includes a chimney, solar panel and a pump as described above.

According to yet another aspect of the invention a method composting material includes the steps of heating liquid in a solar panel, circulating the heated liquid through a liquid tank located below a perforated housing containing material to be composted thereby causing an inflow of fresh air which is heated and in turn heats the material to facilitating the composting of the material.

BRIEF DESCRIPTION OF THE DRAWINGS

The invention will now be described in more detail with reference to the accompanying drawings.

-4-

In the drawings:

Figure 1 shows a perspective view of a waterless toilet;

Figure 2 shows a front view of the toilet;

Figure 3 shows a side view of the toilet;

Figure 4 shows a diagrammatic front view of the hot water tank and drawer of the toilet;

Figure 5 shows a front view of the perforated housing of the toilet;

Figure 6 shows a side view of the perforated housing; and

Figure 7 shows a perspective view of a rake for the perforated housing.

DETAILED DESCRIPTION OF THE ILLUSTRATED EMBODIMENT

Referring firstly to Figure 1, a composter in the form of a waterless toilet 10 includes an outer cover 12 with an opening 14, a toilet seat 16, a toilet seat cover 18 and a chimney 20.

Referring now to Figures 2 to 4, the outer cover 12 has an opening 22, which contains a drawer 24 slidably located in drawer slides and removable from the outer cover 12. A solid rubber baseplate 26 is located below the outer cover 12. The base of the outer cover 12 is located within sidewalls 28 of a tray 30. The base of the tray 30 is formed by the upper surface 32 of a liquid tank, here a flat hot water tank indicated with the reference numeral 34.

Referring now to Figures 5 and 6, a perforated housing or basket 36 has legs 38, four perforated sidewalls 40, an open top 42, an open base 44,

-5-

and a grid 46 formed by spaced pipes 48 located above the open base 44. The perforated housing 36 stands in the tray 30 on the hot water tank 34.

Referring now to Figure 7, rake 50 is provided for raking the manure in the perforated housing 36. The rake has a head 52 with tines 54 and sharpened blades 56 extending in the opposite direction to the tines 54. A handle 58 extends from the head 52. A removable knob 60 is located at the end of the handle 58. The tines 54 locate between the pipes 48 of the grid 46, and the handle 58 of the rake 50 extends from the outer cover 12.

The hot water tank 34 is connected to a solar heater 70 via piping 72. The solar heater 70 includes an electrical solar panel 72 and a pump 74. In this embodiment the electrical solar panel 72 provides electrical power for the pump 74.

In this embodiment of the invention the hot water tank 34 has a capacity of about 10 litres and the total liquid capacity of the solar heater 70 and the hot water tank is in the order of 30 litres. The solar heater 70 is about 1 m² in size. It is envisaged that a suitable anti-freeze can be added to the water to reduce the freezing temperature of the water to prevent the water from freezing and damaging the hot water tank, the solar heater 70 and associated piping.

Although not shown in the drawings insulating means can be provided below the hot water tank. In one embodiment of the invention the insulating means is a layer of closed-cell rubber foam.

In use, the solar heater 70 heats water therein, and the hot water is circulated by the pump 74 through the hot water tank 34. Fresh air is drawn into the outer cover 12 as the air is heated by the hot water. The rising heated air heats manure in the perforated housing 36. The chimney 20 assists in providing a draft and a constant influx of fresh air into the toilet. The rake 50 is periodically moved to and fro to clear any blockages on the grid 46, to shred paper and to aerate the manure in the perforated

-6-

housing 36. Composted material falls through the grid 46 into the drawer 24. The drawer 24 is removed from the toilet to discard the composted material. Any urine in the tray 30 is heated and evaporates. The drawer 24 is spaced from the tray 30, and hence any urine in the tray 30, by drawer slides. This allows the urine to evaporate without hindrance from the drawer 24.

It will be appreciated that many modifications or variations of the invention are possible without departing from the spirit or scope of the invention.

CLAIMS

1. A composter including a liquid tank through which liquid can be circulated, the liquid tank being coupled to or containing a liquid heater, a perforated housing located above the liquid tank and into which perforated housing material to be composted can be discharged, a removable container interposed between the perforated housing and the liquid tank in which receptacle composted material from the perforated housing can be discharged, a cover located over the perforated housing, and a closure in the cover through which closure access can be gained to the perforated housing, so that in use of the composter, air heated by liquid in the liquid tank can pass upwardly through the composter and draw fresh air into the composter to facilitate composting of material in the perforated housing.
2. A composter according to claim 1 wherein the liquid heater is a solar heater, with a closed liquid circuit being formed between the solar heater and the liquid tank.
3. A composter according to claim 2 wherein circulating means is provided between the solar heater and the liquid tank.
4. A composter according to claim 3 wherein the circulating means is a pump.
5. A composter according to claim 4 wherein the pump is powered by an electrical solar panel.
6. A composter according to any one of the preceding claims wherein the liquid tank has a capacity of about 10 litres.
7. A composter according to any one of claims 2 to 6 wherein the total liquid capacity of the solar heater is in the order of 30 litres.

-8-

8. A composter according to any one of claims 2 to 7 wherein the solar heater is 1 m² in size.
9. A composter according to any one of the preceding claims wherein insulating means is provided below the liquid tank.
10. A composter according to claim 9 wherein the insulating means is a layer of closed-cell rubber foam.
11. A composter according to any one of the preceding claims wherein the composter is supported on a base which itself is made of an insulating material.
12. A composter according to claim 11 wherein the base is made of solid rubber.
13. A composter according to any one of the preceding claims wherein the perforated housing is supported on legs and has perforated sidewalls, an open top, and a grid located over an open bottom.
14. A composter according to claim 13 wherein the grid is formed by a plurality of spaced elongate members located at their opposite ends in apertures in opposed sidewalls of the perforated housing.
15. A composter according to claim 14 wherein the elongate members are pipes.
16. A composter according to any one of the preceding claims wherein the composter is a waterless toilet.
17. A composter according to claim 16 including a chimney connected to the cover to facilitate a draft through the composter.
18. A composter according to any one of the preceding claims including

-9-

a toilet seat supported on the cover, and a closure in the form of a toilet seat cover.

19. A composter according to claim 13 wherein the removable container is in the form of a drawer.
20. A composter according to claim 19 wherein the drawer is narrower than the perforated housing so that in use liquid in the form of urine can be discharged through apertures in the sidewalls of the perforated housing onto the liquid tank without entering the drawer.
21. A composter according to either claim 19 or claim 20 wherein the drawer contains some perforations through which any liquid entering the drawer can be discharged.
22. A composter according to any one of the preceding claims wherein the liquid tank has circumferentially upwardly extending sidewalls to form a tray within which urine can collect to be heated by hot liquid in the liquid tank and then evaporated from the tray.
23. A composter according to any one of the preceding claims wherein the liquid which is circulated through the liquid tank is water.
24. A kit for a composter comprising a liquid tank through which liquid can be circulated, the liquid tank being connectable to or containing a liquid heater, a perforated housing for location above the liquid tank and into which perforated housing material to be composted can be discharged, a removable container interposable between the perforated housing and the liquid tank in which receptacle composted material from the perforated housing can be discharged, and a cover locatable over the perforated housing, so that in use of the composter, air heated by liquid in the liquid tank can pass upwardly through the composter and draw fresh air into the composter to facilitate composting of material in the perforated

-10-

housing.

25. A kit for a composter according to claim 24 wherein the composter is a waterless toilet.
26. A kit for a composter according to claim 25 including a chimney, an electrical solar panel and a pump.
27. A method of composting materials including the steps of heating liquid in a solar heater, circulating the heated liquid through a liquid tank located below a perforated housing containing material to be composted thereby causing an inflow of fresh air which is heated and in turn heats the material to facilitating the composting of the material.

1/2

Fig.1

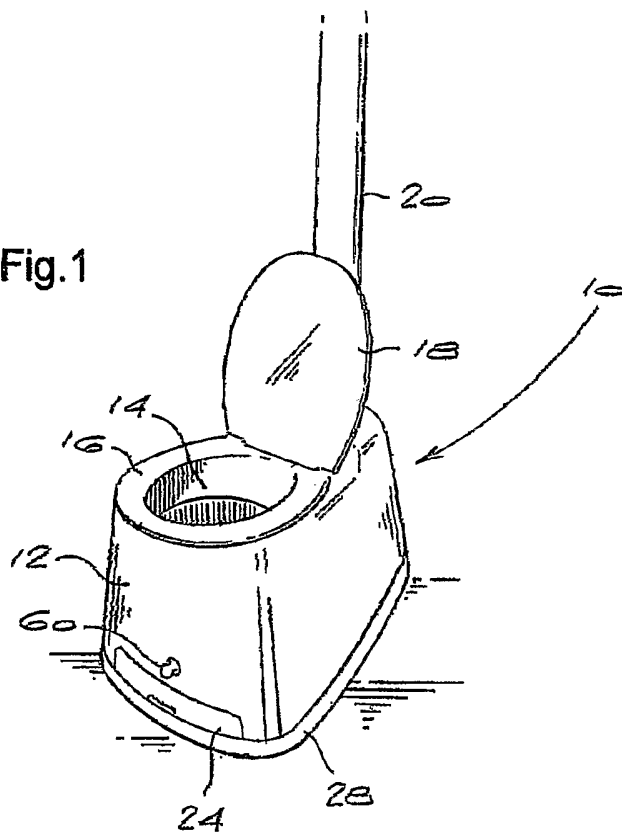

Fig.2

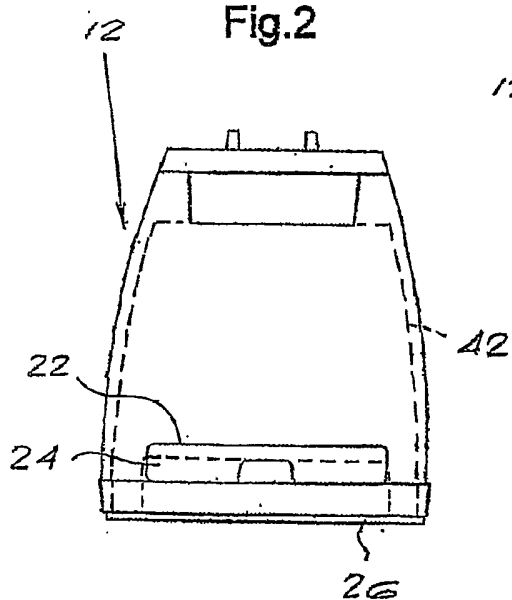
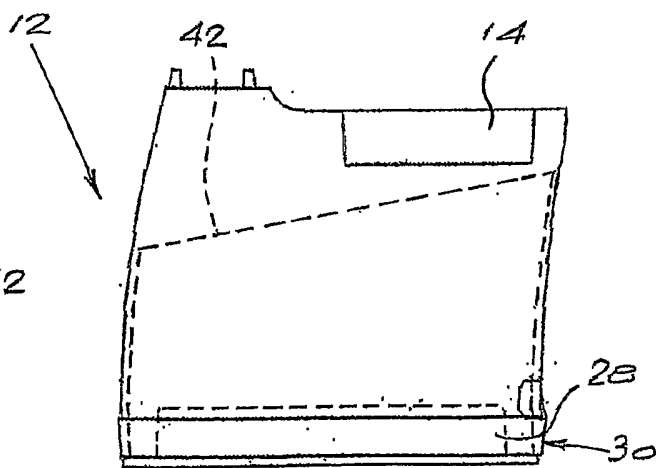
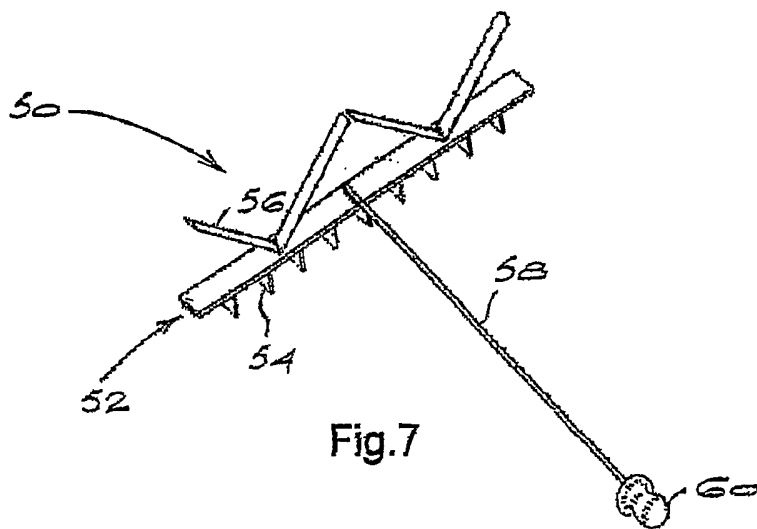
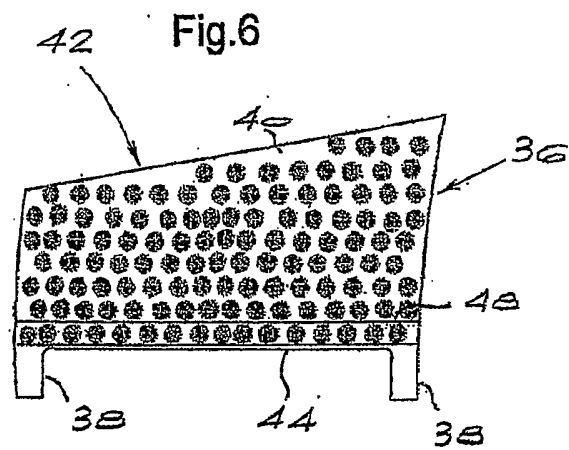
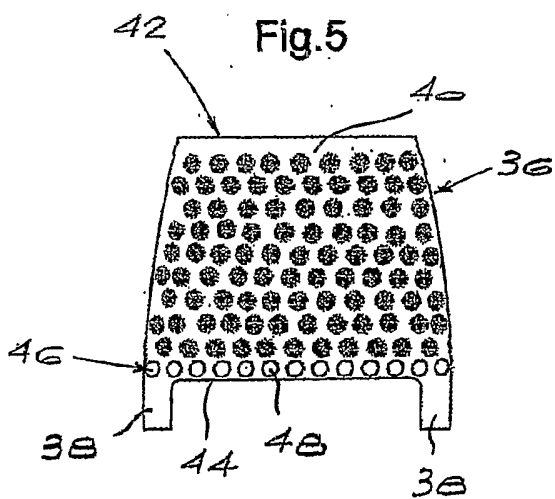
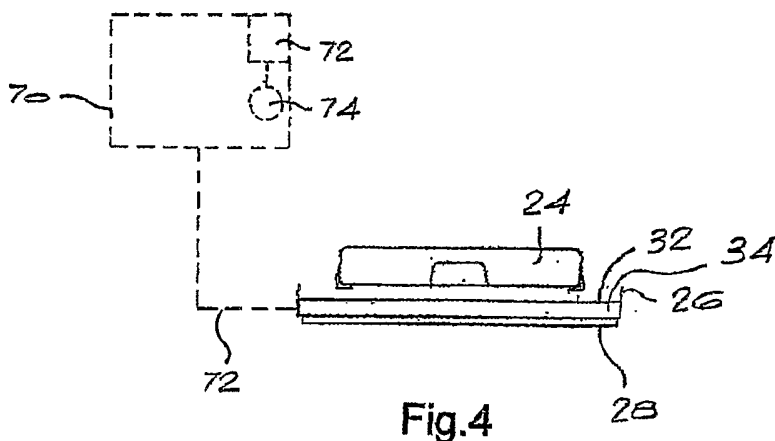

Fig.3





INTERNATIONAL SEARCH REPORT

International application No
PCT/IB2006/000411

A. CLASSIFICATION OF SUBJECT MATTER INV. A47K11/02				
According to International Patent Classification (IPC) or to both national classification and IPC				
B. FIELDS SEARCHED				
Minimum documentation searched (classification system followed by classification symbols) A47K				
Documentation searched other than minimum documentation to the extent that such documents are included in the fields searched				
Electronic data base consulted during the international search (name of data base and, where practical, search terms used) EPO-Internal				
C. DOCUMENTS CONSIDERED TO BE RELEVANT				
Category*	Citation of document, with indication, where appropriate, of the relevant passages	Relevant to claim No.		
X	FR 2 766 696 A (SATNA SOCIETE D'APPLICATION DES TECHNIQUES NOUVELLES D'ASSAINISSEMENT) 5 February 1999 (1999-02-05) page 3, line 21 - page 4, line 15 page 6, line 28 - line 31; figures	1-19, 23-27		
A	US 6 260 216 B1 (LEJGREN HARRY) 17 July 2001 (2001-07-17) column 2, line 2 - line 65; figures	1, 11, 16, 18, 19, 24, 25, 27		
A	EP 0 107 633 A (AKTIEBOLAGET GUSTAVSBERG) 2 May 1984 (1984-05-02) the whole document	1		
----- -/--				
<input checked="" type="checkbox"/> Further documents are listed in the continuation of Box C.				
<input checked="" type="checkbox"/> See patent family annex.				
* Special categories of cited documents :				
<table style="width: 100%; border: none;"> <tr> <td style="width: 50%; border: none; vertical-align: top;"> *A* document defining the general state of the art which is not considered to be of particular relevance *E* earlier document but published on or after the international filing date *L* document which may throw doubts on priority claim(s) or which is cited to establish the publication date of another citation or other special reason (as specified) *O* document referring to an oral disclosure, use, exhibition or other means *P* document published prior to the international filing date but later than the priority date claimed </td> <td style="width: 50%; border: none; vertical-align: top;"> *T* later document published after the international filing date or priority date and not in conflict with the application but cited to understand the principle or theory underlying the invention *X* document of particular relevance; the claimed invention cannot be considered novel or cannot be considered to involve an inventive step when the document is taken alone *Y* document of particular relevance; the claimed invention cannot be considered to involve an inventive step when the document is combined with one or more other such documents, such combination being obvious to a person skilled in the art. *Z* document member of the same patent family </td> </tr> </table>			*A* document defining the general state of the art which is not considered to be of particular relevance *E* earlier document but published on or after the international filing date *L* document which may throw doubts on priority claim(s) or which is cited to establish the publication date of another citation or other special reason (as specified) *O* document referring to an oral disclosure, use, exhibition or other means *P* document published prior to the international filing date but later than the priority date claimed	*T* later document published after the international filing date or priority date and not in conflict with the application but cited to understand the principle or theory underlying the invention *X* document of particular relevance; the claimed invention cannot be considered novel or cannot be considered to involve an inventive step when the document is taken alone *Y* document of particular relevance; the claimed invention cannot be considered to involve an inventive step when the document is combined with one or more other such documents, such combination being obvious to a person skilled in the art. *Z* document member of the same patent family
A document defining the general state of the art which is not considered to be of particular relevance *E* earlier document but published on or after the international filing date *L* document which may throw doubts on priority claim(s) or which is cited to establish the publication date of another citation or other special reason (as specified) *O* document referring to an oral disclosure, use, exhibition or other means *P* document published prior to the international filing date but later than the priority date claimed	*T* later document published after the international filing date or priority date and not in conflict with the application but cited to understand the principle or theory underlying the invention *X* document of particular relevance; the claimed invention cannot be considered novel or cannot be considered to involve an inventive step when the document is taken alone *Y* document of particular relevance; the claimed invention cannot be considered to involve an inventive step when the document is combined with one or more other such documents, such combination being obvious to a person skilled in the art. *Z* document member of the same patent family			
Date of the actual completion of the international search <p style="text-align: center;">3 August 2006</p>		Date of mailing of the international search report <p style="text-align: center;">10/08/2006</p>		
Name and mailing address of the ISA/ European Patent Office, P.B. 5818 Patentlaan 2 NL - 2280 HV Rijswijk Tel. (+31-70) 340-2040, Tx. 31 651 epo nl, Fax: (+31-70) 340-3016		Authorized officer <p style="text-align: center;">Fordham, A</p>		

3

INTERNATIONAL SEARCH REPORT

International application No
PCT/IB2006/000411

C(Continuation). DOCUMENTS CONSIDERED TO BE RELEVANT		
Category*	Citation of document, with indication, where appropriate, of the relevant passages	Relevant to claim No.
A	FR 2 722 810 A (SATNA SOCIETE D APPLICATION DES TECHNIQUES NOUVELLES D ASSAINISSEMENT) 26 January 1996 (1996-01-26) the whole document -----	1
A	GB 1 459 117 A (SUNDBERG T M) 22 December 1976 (1976-12-22) the whole document -----	1

INTERNATIONAL SEARCH REPORT

 International application No
 PCT/IB2006/000411

Patent document cited in search report		Publication date	Patent family member(s)	Publication date
FR 2766696	A	05-02-1999	NONE	
US 6260216	B1	17-07-2001	AU 2648799 A CA 2319808 A1 NO 20003690 A SE 511300 C2 SE 9800320 A WO 9940044 A1	23-08-1999 12-08-1999 04-10-2000 06-09-1999 06-08-1999 12-08-1999
EP 0107633	A	02-05-1984	FI 833606 A NO 833623 A SE 433491 B SE 8205781 A	12-04-1984 12-04-1984 28-05-1984 12-04-1984
FR 2722810	A	26-01-1996	NONE	
GB 1459117	A	22-12-1976	NONE	