

(No Model.)

L. REASER.  
STOVEPIPE ATTACHMENT.

No. 526,260.

Patented Sept. 18, 1894.

Fig. 1.

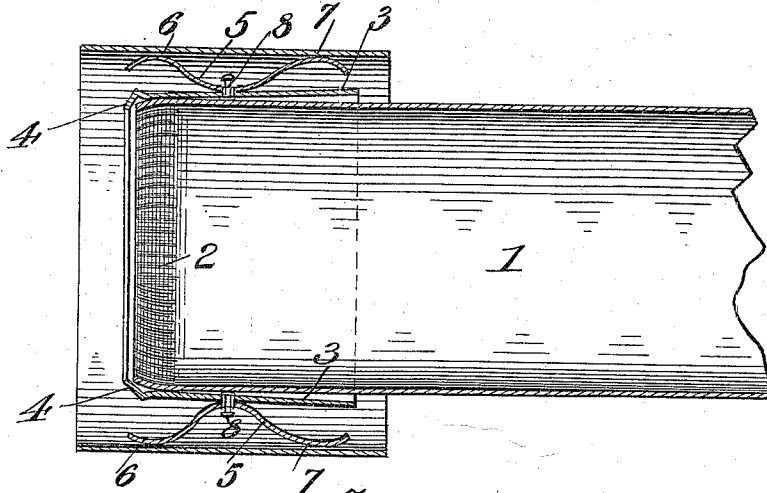

Fig. 2.

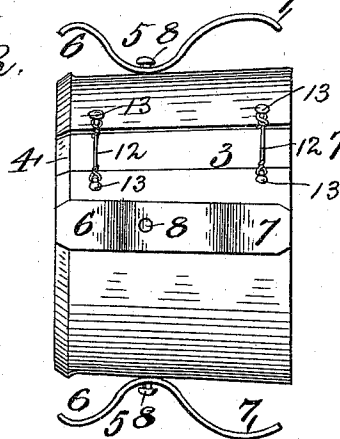

Fig. 3.

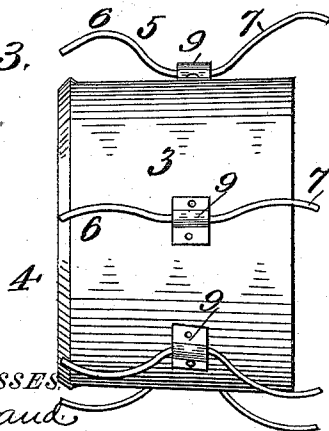
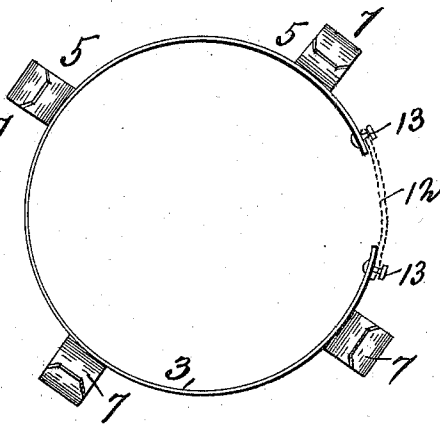

Fig. 4.



WITNESSES  
H. L. Curant  
W. D. Coombs

INVENTOR:  
Lewis Reaser,  
by Lewis Duggan & Co.,  
Attorneys.

# UNITED STATES PATENT OFFICE.

LEWIS REASER, OF READING, PENNSYLVANIA.

## STOVEPIPE ATTACHMENT.

SPECIFICATION forming part of Letters Patent No. 526,260, dated September 18, 1894.

Application filed May 7, 1894. Serial No. 510,375. (No model.)

### *To all whom it may concern:*

Be it known that I, LEWIS REASER, a citizen of the United States, and a resident of Reading, in the county of Berks and State of Pennsylvania, have invented certain new and useful Improvements in Stovepipe Attachments; and I do hereby declare that the following is a full, clear, and exact description of the invention, which will enable others skilled in the art to which it appertains to make and use the same, reference being had to the accompanying drawings, which form a part of this specification.

My invention relates to improvements in attachments for stove pipes, adapted to be used in connection with stove pipe thimbles which are of a diameter larger than that of the pipe, so that when the latter is inserted in place, a space will be left between the pipe and thimble for ventilating purposes.

The object of the invention is to provide an attachment, which can readily be attached to an ordinary pipe, consisting essentially of a short tapering cylindrical section, provided on its periphery with a series of spring arms which abut against the under side of the thimble when the section is inserted therein, so as to hold the pipe in place, as will be hereinafter fully described and claimed.

In the accompanying drawings: Figure 1 is a central longitudinal section showing a stove pipe and thimble with my improved attachment connected therewith. Fig. 2 is a side elevation of the attachment disconnected from the pipe and thimble. Fig. 3 is a similar view showing a modification in the construction of the spring arms. Fig. 4 is an end view of the cylindrical section in which the stove pipe is inserted.

In the said drawings the reference numeral 1 designates an ordinary stove pipe, having one end crimped, as usual, as seen at 2.

The numeral 3 designates a short cylindrical section, or curved metal plate slightly tapering from end to end, so that the crimped end of the stove pipe can be readily inserted therein, and having its inner end turned or bent inwardly forming an annular flange 4, which engages with the end of the pipe when the latter is inserted in the section whereby its movement is limited.

The numeral 5, Figs. 1 and 2, designates a number of spring levers consisting of metal plates bent or curved intermediate their ends forming a short inner arm 6 and a long outer arm 7. These levers are loosely connected with the periphery of the cylinder, by means of rivets 8, so as to rock thereon, the bend or curve serving as a fulcrum.

In the modification shown in Fig. 3, the arms 6 and 7 are formed of spring wire and are connected with the cylinder by means of sockets 9.

The operation will be readily understood. The crimped end of the stove pipe is inserted in the enlarged end of the cylinder and the latter slipped over the same until the flange 4 comes in contact with the crimped end thereof where its further movement is stopped. The cylinder will now be securely connected with the pipe being held thereon by frictional contact, and is then inserted in the thimble, until the long arms 7, which for convenience I term the outer arms, come in contact with the sides of the thimble. Said arms will then be depressed or pushed inwardly causing the short arms 6, to be forced outwardly so as to bear against the inner side of the thimble. By this construction the cylinder can be readily inserted in the thimble as the short arms will readily yield and not be pressed against the thimble until forced outwardly by the long arms coming in contact with the thimble when the cylinder is pushed home. I also obtain the advantages of leverage due to the differential arms, whereby the cylinder is securely held in place. In withdrawing the cylinder from the thimble, as soon as the long arms clear the outer ends of the latter, the pressure of the short arms on the thimble will be relieved thereby decreasing the frictional contact and allowing the cylinder to be readily slipped out.

It will be seen that the ends of the curved plate 3, to which the spring levers are secured, are connected together by means of wires 12, the ends of which are coiled around studs 13, near the adjoining edges or ends of the plate. By this means, by lengthening or shortening said wires, the cylinder or plate may be made to fit pipes of varying diameters.

Having thus described my invention, what I claim is—

5 As an improved article a stove pipe attachment consisting of a short tapering curved metal plate having an inwardly turned flange at its small end, and provided with studs and connecting wires near its adjoining edges, and the spring levers connected with the periphery thereof, bent or curved interme-

diate their ends, forming short arms; substantially as and for the purpose specified. 10

In testimony that I claim the foregoing as my own I have hereunto affixed my signature in presence of two witnesses.

LEWIS REASER.

Witnesses:

LOUIS BAGGER,  
BENNETT S. JONES.