

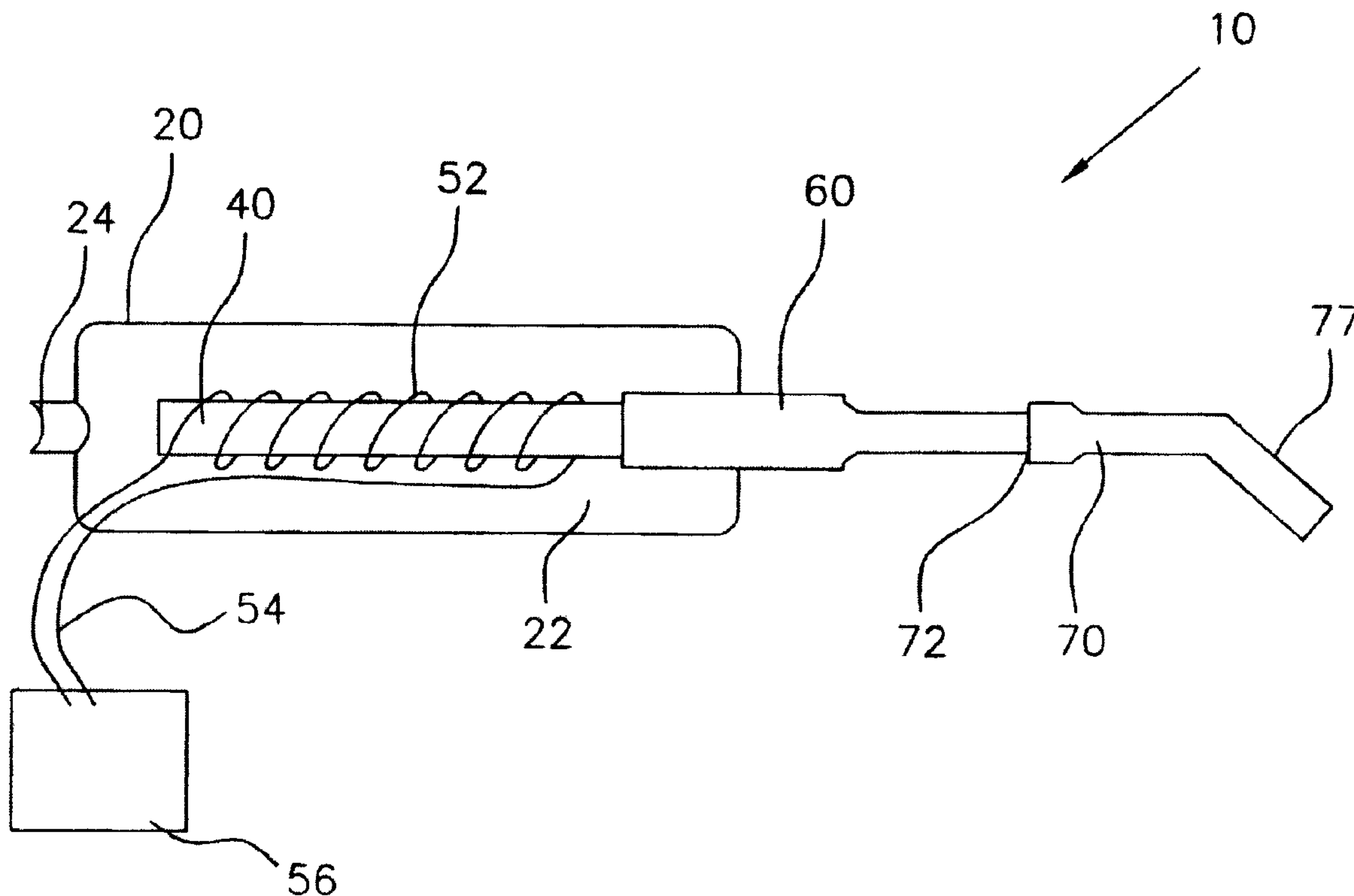

(22) Date de dépôt/Filing Date: 2005/03/14  
(41) Mise à la disp. pub./Open to Public Insp.: 2006/09/10  
(30) Priorité/Priority: 2005/03/10 (USUNKNOWN)

(51) Cl.Int./Int.Cl. *A61B 17/00* (2006.01),  
*A45D 44/22* (2006.01), *A61B 19/00* (2006.01),  
*A61H 1/00* (2006.01)  
(71) Demandeur/Applicant:  
PAN GERMINAL SYSTEMS USA, L.L.C., US  
(72) Inventeurs/Inventors:  
MULHOLLAND, ROBERT STEPHEN, CA;  
BROADWIN, ALAN, US  
(74) Agent: BORDEN LADNER GERVAIS LLP

(54) Titre : APPAREIL D'ABRASION PELLICULAIRE  
(54) Title: SKIN ABRADING APPARATUS



(57) **Abrégé/Abstract:**

A hand held skin abrading apparatus is provided. The apparatus comprises a handle configured for gripping by a human operator; a reciprocating motion generator, in the form of a magnetostrictive ultrasonic transducer, associated with the handle; an applicator attached to the handle and having an applicator blade for applying abrading motion to a surface and a coupler for coupling the applicator to the magnetostrictive ultrasonic transducer. The applicator is releasably securable to the handle of a skin abrading apparatus and includes a connector portion extending from the applicator blade, the connector portion having a central axis, wherein the applicator blade is offset from the central axis to enable the apparatus to be operated with the handle above the plane of the surface being abraded. The apparatus may include provision for irrigation of the surface being abraded.

**ABSTRACT**

A hand held skin abrading apparatus is provided. The apparatus comprises a handle  
5 configured for gripping by a human operator; a reciprocating motion generator, in the  
form of a magnetostrictive ultrasonic transducer, associated with the handle; an  
applicator attached to the handle and having an applicator blade for applying abrading  
motion to a surface and a coupler for coupling the applicator to the magnetostrictive  
10 ultrasonic transducer. The applicator is releasably securable to the handle of a skin  
abrading apparatus and includes a connector portion extending from the applicator  
blade, the connector portion having a central axis, wherein the applicator blade is offset  
from the central axis to enable the apparatus to be operated with the handle above the  
plane of the surface being abraded. The apparatus may include provision for irrigation  
of the surface being abraded.

15

## **SKIN ABRADING APPARATUS**

### **5 FIELD OF THE INVENTION**

The invention relates to a skin-abrading device, generally. In particular, the invention relates to hand held skin abrading devices.

### **10 BACKGROUND OF THE INVENTION**

People with skin imperfections, such as fine lines and wrinkles, pigment abnormalities and acne or sun damaged skin, have long sought to have them removed. Over the past 100 years, several methods and devices have been employed to this end. For example, chemical peels, dermabrasive devices (such as high speed burrs, abrasive paper or  
15 wire brushes), lasers and ultrasonic devices have been used to remove layers of the stratum corneum of the epidermis. Each of these methods and devices, however, has important shortcomings that preclude their widespread use.

Dermabrasive devices, such as wire brushes, fraises and abrasive papers usually  
20 require a topical anesthetic and result in a "brush burned" feeling, some swelling and newly formed pink skin. Healing takes place usually over a 7 to 10 day period, with a return to normal appearance usually in 8 to 12 weeks. Further, controlled removal of epidermal layers is very difficult and requires considerable skill. Chemical peels require the use of glycolic or other acids, and carry the difficulties and risks associated with the  
25 application of an active liquid to the face, especially near the eyes. Lasers are a very expensive alternative, which requires significant training and special precautions associated with laser safety. Further, it is not easy to cover broad areas of the face evenly and quickly.

30 Although ultrasonic vibrating members utilizing piezoelectric transducers have demonstrated the ability to remove tissue delicately and precisely, layer by layer. These

devices have in the past been prone to fatigue failure and have not been able to sustain a desired motion under load.

5 It is an object of the present invention to provide an ultrasonic skin abrading device that can remove tissue delicately and precisely, is not prone to fatigue failure and is able to sustain its intended motion under load.

10 What is needed is a device that would be comfortable to hold and operate. This dictates a device that is relatively short and has a small diameter. It also dictates a rather broad applicator which is angled to allow a comfortable hand position for the user. The device needs to be reliable and not break after short periods of use. This dictates an acoustic design that would have minimum flexural component so as not to fatigue. The device must be biocompatible since the applicator would be in contact with the skin. This dictates a titanium alloy whose main attribute for this design is its biocompatibility, not its  
15 high strength properties which are well known in the ultrasonic transducer field.

To solve the above problems, applicants investigated the possibility of adapting and improving on existing dental devices. The inventors found that such existing devices were problematic to modify and/or engineers for the manufacturers were very skeptical  
20 about the possibility of using their device for a cosmetic application. Accordingly, the inventors recognized the need to develop this novel present invention disclosed herein.

By way of further explanation regarding the state of the art of ultrasonic surgical devices, international standard (IEC 61847) published in 1998 which addresses measurement  
25 and declaration of the basic output characteristics of Ultrasonic Surgical Systems, Annex B 3 states: "Although in use for over twenty years, little is known about what mechanism causes tissue fragmentation and the selective removal of tissue. It is believed that at least one of the mechanisms is the force created by cavitation bubbles imploding in cellular fluid and in the microscopic convolutions of hard or brittle tissue.  
30 Ultrasonic surgical device applicator tips having sharp features also apparently cause tissue cutting or tearing by the simple mechanism of rapid sharp cutting. Since ultrasonically vibrating members have very high surface velocities, another effect seen is the frictional heat generated by the side of the tip when its unprotected portion rubs against tissue. This effect can have two outcomes. One, it can damage sensitive tissue  
35 which is not intended for removal. Second, it may account for some of the secondary cauterizing effects which are observed in surgery and are in fact desired in some applications. Note: The velocity of the distal end of a surgical tip vibrating at 23 kHz and

350 $\mu$ m .....” Note: The 23 kHz and 350 $\mu$ m are numbers which would give the 50,000g's number that US Patent No. 3,213,537 to Balamuth cites for a surgical device, as further discussed below.

## 5 SUMMARY OF THE INVENTION

The present invention takes sterile water and pumps it into the back of the transducer chamber, going through the transducer chamber it surrounds the magnetostrictive laminations and cools them. This same water is discharged through a tube at the front of the handpiece and onto the vibrating applicator blade (which is blunt as opposed to  
10 the sharp output edge blade typical of prior art devices. No suction is used. The fluid makes one pass through the present invention.

The following are calculations for acceleration at the end of the applicator of the present invention:

15 Acceleration = .5 Peak to Peak excursion x  $(2\pi f)^2/9.8 = "g"$ ;  
Peak to Peak excursion for the present inventive applicator = .001", thus .001 x  
1/2 = .0005" = .00001 meters;  
.00001  $(2 \times 3.14 \times 30,000)^2 / 9.8 = 36,218 \text{ g's}$

20 As mentioned above, prior art devices such as that disclosed in the above cited Balamuth patent call for accelerations of at least 50,000 g's, which is incompatible for the intended cosmetic use for the present invention.

The action on tissue depends on the amplitude and velocity of the oscillations at the  
25 distal end of the applicator. Thus we know that a surgical ultrasonic device, designed for fragmentation, emulsification and aspiration of tissue, which operates at 23 kHz and has a peak to peak excursion of 0.012" = 300 $\mu$ , has a velocity of 2,208 cm/sec. This is a similar magnitude to a dermabrasion brush which is 3/4" in diameter, rotating at 28,000 rpm and has a velocity of 2,785 cm/s.

30 These contrast to the present invention, which has a peak to peak excursion of 0.001" = 25 $\mu$  and has a velocity of 200 cm/s. Indeed, this is a similar magnitude to a dental scaler, which is used for abrading tissue rather than fragmenting or cutting it.

It is clear that prior art devices such as those disclosed in the Balamuth patent disclose  
35 a device used primarily for micro-chopping tissue for removal of tonsils, warts, cysts, or the like, including compliant body tissue for biopsy testing. The fluid ports are near the tool itself to serve as flushing and suction ports to remove the tissue and collect it. The

fluid must be antiseptic because effectively what is being preformed is micro-surgery to remove and collect organ tissue. Antiseptic fluid may have alcohol, which is not a type of fluid, which should be subjected to heat from an electrical device. In the instant invention, the device is designed to run a cooling fluid through the cavity of the handle, which houses the electrical components, which build up heat. Such heat can overheat the magnetostrictive ultrasonic transducer, as well as the handle, making the handle too hot to hold and making the transducer operate inefficiently or inoperable.

It is important to understand that the present invention was developed for cosmetic use, not surgical use. The cutting of tissue is an undesirable feature.

Although there are many ultrasonic devices which have angulated applicators, the usual configurations end up with significant flexural as well as longitudinal motion. Flexural motion usually results in premature fatigue failure of a device. Thus the particular angle and dimensions of the blade are designed to minimize or eliminate any flexural mode of the applicator. The result is a controlled energy director which has enhanced life and reliability and provides the physician with an improved device.

One of the objects of prior art devices such as that disclosed in the above mentioned Balamuth patent, is to provide maximum amplitude of vibration and maximum transmission of working energy to the work tool. The present invention is designed so that there is little or no amplification of motion in the applicator so that the physician will get the same abrading effect on the patient no matter where the applicator is touched. In addition, the maximum power of the device chosen limits the energy to the patient. These are important safety features for a medical device where, since the application is cosmetic, the risk to the patient must be as low as possible.

The use of titanium is well known in the ultrasonic field because of its high strength and fatigue limits. The selection of 6AL4V titanium material however was dictated by the need to be biocompatible with human tissue. In addition, there is a need to align the grain of the applicator with the axis of the applicator. This is intended to highlight the acoustic properties of the selected material not only its strength and fatigue properties. It is important to select a material which does not have high acoustic losses which would cause excess heating and pose a safety threat to the patient or cause premature fracture and failure. Thus there is an unexpected result of selecting the cited material and describing the orientation of its grain structure.

The present invention provides an ultrasonic skin abrading apparatus comprising a handle configured for gripping by a human operator; a reciprocating motion generator, in the form of a magnetostrictive ultrasonic transducer, associated with the handle; and a coupler for coupling the magnetostrictive ultrasonic transducer to an applicator. The applicator includes an applicator blade for applying abrading motion to a surface.

The invention further provides that the magnetostrictive ultrasonic transducer may comprise a stack of magnetostrictive laminations insertable into the cavity of the handle, which includes at least one electronically conducting coil for surrounding the stack and inducing an electromagnetic field in the stack in response to electrical current flow in the coil thereby causing longitudinal movement in the stack.

The present invention further provides an applicator for use with a skin abrading apparatus, wherein the applicator is releasably securable to the handle of a skin abrading apparatus and includes an applicator blade for applying a reciprocating abrading motion.

The invention further provides that the applicator may include a connector portion extending from the applicator blade, the connector portion having a central axis, wherein the applicator blade is offset from the central axis to enable the apparatus to be operated with the handle above the plane of the surface being abraded.

The applicator blade may include at least one hole extending therethrough for allowing fluid passage therethrough onto an underlying surface.

More particularly, the present invention claimed is a surgical device for use as a skin abrading non-aspirating apparatus. The apparatus comprises a handle configured for gripping by a human operator; a reciprocating motion generator associated with said handle; an applicator releasably securable to the handle and having an applicator blade for applying abrading motion; and a coupler or coupler means for coupling said applicator to the reciprocating motion generator and for transferring reciprocating motion from the reciprocating motion generator to said applicator blade.

The reciprocating motion generator is a magnetostrictive ultrasonic transducer. The handle has a cavity in an interior thereof, the cavity receiving and extending about the magnetostrictive ultrasonic transducer.

A fluid inlet is located near one end of the handle, fluidly communicating with the cavity for supplying fluid to the cavity from a fluid source. A fluid outlet is located near an opposite end of the handle, fluidly communicating with the cavity for discharging fluid from the cavity.

5

The magnetostrictive ultrasonic transducer further comprising a stack of magnetostrictive laminations insertable into the cavity and the cavity includes at least one electronically conducting coil for surrounding the stack and inducing an electromagnetic field in the stack in response to electrical current flow in the coil. The stack is caused to longitudinally move.

10

The coupler mechanically couples the applicator to the stack and the apparatus has a fluid conduit means associated with the fluid outlet for directing the fluid onto the applicator blade.

15

The fluid serves as a cooling fluid, wherein the cooling fluid, cavity and flow of the cooling fluid from the fluid inlet end of the cavity, through the cavity and out the fluid outlet from the cavity removes a heat generated within the cavity of the handle by the magnetostrictive ultrasonic transducer to prevent the magnetostrictive ultrasonic transducer and handle from overheating.

20

The fluid conduit means including at least one irrigation passage extending from the cavity and through the coupler. The at least one electronically conducting coil is connected to an ultrasonic generator capable of generating an electrical current having an ultrasonic frequency. The ultrasonic generator converts a 50 - 60 Hz AC input current into an ultrasonic frequency output current and causes the magnetostrictive ultrasonic transducer to vibrate at ultrasonic frequencies.

25

The skin abrading non-aspirating apparatus further is adapted for use in cosmetic procedures, wherein the magnetostrictive ultrasonic transducer is adapted to operate so as to vibrate at a vibrating frequency of between 28 and 32 kHz, preferably about 30 kHz. The applicator blade is operable so as to have a reciprocating amplitude of vibration of between 12 and 37 microns, preferably about 25 microns. The applicator blade is also adapted to have an application angle and dimension to minimize or eliminate any flexural mode of the applicator blade.

35

The skin abrading apparatus further comprises means for eliminating high acoustic losses which would cause excess heating and pose a safety threat to a patient or cause premature fracture or failure. This is accomplished by constructing or forming the applicator blade with titanium material, preferably 6AL4V titanium, wherein the titanium  
5 material has a grain direction aligned with a longitudinal axis of the applicator blade.

When in use at the operable range of vibrating frequency and reciprocating amplitude of vibration, the apparatus is adapted to be capable of microbrading a stratum corneum of an epidermis without cutting, chopping or cavitating the skin of the patient.

10

In an embodiment according to that described above, the magnetostrictive ultrasonic transducer is releasably securable to the handle and the coupler acts between the stack and the applicator. In another embodiment, the applicator includes a connector portion extending from said applicator blade, for securing the applicator to the coupler. The  
15 fluid conduit means includes at least one irrigation passage extending through the connector portion.

A standing wave is associated with the reciprocating motion of the applicator. The standing wave has nodes, which correspond to areas of minimum reciprocating  
20 amplitude of displacement, and anti-nodes, which correspond to areas of maximum reciprocating amplitude of displacement, wherein the applicator is of a length such that the applicator blade is located at an anti-node.

In another embodiment, the applicator blade includes at least one abrading surface, preferably two surfaces. At least one abrading surface includes at least one ridge  
25 extending transversely across the abrading surface and defining a ridge abrading surface. In the case where there are two abrading surfaces, each surface may include at least one ridge extending transversely across each abrading surface and defining respective ridge abrading surfaces. The ridge may extend transversely across at least one abrading surface, adjacent to an outer edge.

30

The coupler includes a shaft extending to the applicator blade. The shaft preferably has a central axis, wherein the applicator blade is offset from the central axis to enable the apparatus to be operated with the handle above the plane of the surface being abraded.

35 The applicator blade is preferably spatulate in shape and may include a flared portion and a rectangular portion. The rectangular portion is offset from the central axis to

enable the apparatus to be operated with the handle above the plane of the surface being abraded.

The rectangular portion preferably meets the flared portion at an angle of between 90 degrees and 180 degrees relative to the central axis, preferably 150 degrees. The angle defines an outer vertex, adjacent to which at least one ridge extends and defines a ridge-abrading surface or on which at least one ridge extends and defines a ridge-abrading surface.

The applicator blade includes at least one hole, aperture, slit or slot opening or the like, extending therethrough for allowing fluid passage therethrough onto an underlying surface, located on the flared portion of said applicator blade.

As discussed above, the present invention includes the applicator, which is releasably securable to a handle of a skin abrading apparatus, and comprises an applicator blade for applying a reciprocating abrading motion at a vibrating frequency of between 28 and 32 kHz and a reciprocating amplitude of vibration of between 12 and 37 microns. The applicator blade is adapted to have an application angle and dimension to minimize or eliminate any flexural mode of the applicator blade. It is made of titanium material, preferably 6AL4V titanium, where the titanium material has a grain direction aligned with a longitudinal axis of said applicator blade.

The applicator having a connector portion extending from said applicator blade, for securing the applicator to a coupler. The connector portion includes a fluid conduit for directing fluid from a fluid supply onto said applicator blade. The fluid conduit includes at least one irrigation passage for extending through the connector portion.

The applicator blade includes at least one hole extending therethrough for allowing fluid passage therethrough onto an underlying surface. A standing wave is associated with the reciprocating motion of the applicator blade. The standing wave has nodes, which correspond to areas of minimum reciprocating amplitude of displacement, and anti-nodes, which correspond to areas of maximum reciprocating amplitude of displacement, and the applicator is of a length such that the applicator blade is located at an anti-node.

When the apparatus is in use at the operable range of vibrating frequency and reciprocating amplitude of vibration, the applicator blade is adapted to be capable of microabrading a stratum corneum of an epidermis without cutting, chopping or cavitating the skin of the patient.

The applicator blade includes at least one abrading surface. In one embodiment, it has two such surfaces. At least one abrading surface includes at least one ridge extending transversely across the abrading surface and defining a ridge abrading surface. In the case where there are two abrading surfaces, each surface may include at least one  
 5 ridge extending transversely across each abrading surface and defining respective ridge abrading surfaces. The ridge may extend transversely across at least one abrading surface, adjacent to an outer edge.

The coupler includes a shaft extending to the applicator blade. The shaft preferably has  
 10 a central axis, wherein the applicator blade is offset from the central axis to enable the apparatus to be operated with the handle above the plane of the surface being abraded. The applicator blade is preferably spatulate in shape and may include a flared portion and a rectangular portion. The rectangular portion is offset from the central axis to enable the apparatus to be operated with the handle above the plane of the surface  
 15 being abraded.

The rectangular portion preferably meets the flared portion at an angle of between 90 degrees and 180 degrees relative to the central axis, preferably 150 degrees. The angle defines an outer vertex, adjacent to which at least one ridge extends and defines  
 20 a ridge-abrading surface or on which at least one ridge extends and defines a ridge-abrading surface.

The applicator blade includes at least one hole, aperture, slit or slot opening or the like, extending therethrough for allowing fluid passage therethrough onto an underlying  
 25 surface, located on the flared portion of said applicator blade.

### **BRIEF DESCRIPTION OF THE DRAWINGS**

30 Preferred embodiments of the present invention are described below with reference to the accompanying drawings in which:

Fig. 1 is a schematic view illustrating a skin abrading apparatus according to the present invention connected to an ultrasonic converter/generator;

35 Fig. 2 is an axial section of a handle of a skin abrading apparatus according to the present invention illustrating schematically the parts housed within;

Fig. 3 is a schematic view illustrating a magnetostrictive ultrasonic transducer component of a skin abrading apparatus according to the present invention and an attached coupler;

Fig. 4 (a – b) are axial sectional views illustrating alternate embodiments of a  
5 coupler component of a skin abrading apparatus according to the present invention;

Figs. 5 (a – b) are axial sectional views illustrating alternate embodiments of an applicator component for a skin abrading apparatus according to the present invention and an attached coupler;

Fig. 6a is a side elevation sectional view of an applicator component for a skin  
10 abrading apparatus according to the present invention;

Fig. 6b is a plan view of the applicator component of Fig. 6a; and  
Figs. 7 (a – i) are side elevations illustrating alternate embodiments of an applicator blade component of an applicator for a skin abrading apparatus according to the present invention.

15

### **DETAILED DESCRIPTION OF THE INVENTION**

Fig. 1 illustrates a skin abrading apparatus (SAA) 10 made in accordance with a  
20 preferred embodiment of the invention. The SAA 10 is adapted to apply abrading motion to a surface by using reciprocating motion generated by a magnetostrictive ultrasonic transducer (MUT) 40.

The SAA 10 includes a handle 20 configured for gripping by a human operator; a  
25 reciprocating motion generator, in the form of the MUT 40 associated with the handle 20; a coupler 60 for coupling the MUT 40 to an applicator 70. The applicator 70 has an applicator blade 77 for applying abrading motion to a surface.

Referring now to Figs. 1 – 3, the handle 20 includes a cavity 22 that is configured to  
30 receive and extend about the MUT 40. A fluid inlet 24 fluidly communicates with the cavity 22 for supplying fluid to the cavity 22 from a fluid source (not shown). A fluid outlet 64, fluidly communicates with the cavity 22 for discharging fluid from the cavity 22. Since the reciprocating motion of the MUT 40 generates heat, a cooling fluid is circulated through the cavity 22 in order to prevent the MUT 40 and handle 20 (and the  
35 components it houses) from overheating. In a preferred embodiment of the invention, water is used as the cooling fluid. In an alternate embodiment, a saline solution is used.

However, any other fluid known in the art, which acts to cool the heated handle components may be used. To avoid leakage, an O-ring 28 is positioned between the inner surface 30 of the handle 20 and an outer surface 62 of coupler 60, thereby creating a leak resistant seal.

5

Fluid may for be provided from a sterile fluid bag pressurized with an inflatable cuff, such as a blood-pressure cuff. Other sources of pressurized fluid will no doubt be apparent to those skilled in the relevant art. According to a preferred embodiment of the present invention, the cooling fluid may also be used to irrigate the area being abraded.

10 In such an arrangement, the selected fluid must be compatible with the human body.

The MUT 40 comprises a stack 50 of magnetostrictive laminations 42 that are fabricated from a magnetostrictive material, such as a nickel alloy. The laminations 42 are coated with a layer 44 of an oxide, which serves to insulate the adjacent laminations 42 from each other. The laminations 42 are brazed together at opposite ends 46 and 48, thereby forming the magnetostrictive stack 50. The brazing of the ends 46 and 48 ensures that the laminations 42 remain bonded together during operation and also provides mechanical contact between the laminations 42 and the coupler 60. The applicator 70, coupler 60 and MUT 40 may be releasably securable to the handle 20 thereby permitting them to be separated from handle 20 for maintenance and to be sterilized.

The cavity 22 also includes at least one electronically conducting coil 52 for surrounding the stack 50 and inducing an electromagnetic field in the stack 50 in response to electrical current flow in the coil 52, thereby causing longitudinal movement in said stack. The coil 52 is connected to an ultrasonic generator 56 via connecting wires 54. The ultrasonic generator 56 is capable of generating a varying electrical current having an ultrasonic frequency. The ultrasonic generator 56 may for example be a Cavitron® Select™ SPS™ Ultrasonic Scaler, as sold by DENTSPLY® Professional of York, PA, USA. The ultrasonic generator 56 converts a 50 - 60 Hz AC input current into an ultrasonic frequency output current, thereby causing the MUT 40 to vibrate at ultrasonic frequencies of between 28 and 32 kHz. In a preferred embodiment, MUT 40 vibrates at a vibrating frequency of 30 kHz.

35 When the ultrasonic current passes through the coil 52, a magnetic field is induced, the direction of which is parallel to a longitudinal axis 34 of the laminations 42 of the magnetostrictive stack 50. In response to the generated magnetic field, the stack 50

strains and exhibits a corresponding change in length. It is this change in length (or reciprocating amplitude of vibration), which results from the magnetic coupling between the wire coils 52 and the magnetostrictive stack 50, that is passed on to the applicator 70 (and therefore applicator blade 77) through the coupler 60. The resulting  
5 reciprocating amplitude of vibration of the applicator blade 77 would typically be between 12 and 37 microns. Testing suggests that preferably the applicator blade 77 have a reciprocating amplitude of vibration of 25 microns, peak to peak.

Advantages of using a magnetostrictive ultrasonic transducer rather than a piezoelectric  
10 transducer are realized in longevity, performance and safety. The magnetostrictive ultrasonic transducer is more rugged and acoustically less sensitive to frequency and loading. Furthermore, the power supply is electrically isolated from the magnetostrictive stack as it is magnetically rather than electrically coupled thereto. In contrast, a  
15 piezoelectric device requires a very high voltage to be applied to the piezoelectric crystals, which in turn are directly mounted to the applicator assembly requiring electrical isolation and carrying the attendant risks of the electrical isolation breaking down.

The SAA 10 may have a fluid conduit means for directing a cooling fluid, such as water  
20 or a saline solution, onto applicator blade 77. In a preferred embodiment of the invention, the fluid that is used for cooling the handle is discharged onto the applicator blade 77. Accordingly, the fluid conduit means may include at least one irrigation passage 64 extending from the cavity 22 and through the coupler 60.

25 Referring now to Figs. 1 and 5, the applicator 70 is releasably securable to the coupler 60. In a preferred embodiment of the invention, a connector portion 75 extends from the applicator 70 and attaches to the coupler 60 by a threaded joint 72, thereby enabling the applicator 70 to be removed for possible maintenance to replacement. However, any  
30 other attachment means known in the art, which permits the applicator 70 to be removed for possible maintenance to replacement, may be employed.

Referring now to Figs. 2, 4 (a-b), 5 (a-b) and 6 (a-b), which are axial sectional views illustrating alternate embodiments of the coupler 60, the coupler 60 includes a shaft 65 extending to the applicator 70. The shaft 65 has a central longitudinal coupler axis 66.  
35 In a preferred embodiment illustrated in Figures 4a and 5a, the coupler 60 includes a fluid conduit means extending through the MUT connector portion 67 in the form of at least one irrigation passage 64 and a tube 76, which registers therewith and which

combine to direct a cooling fluid such as water from the cavity 22 to the applicator blade 77, thereby cooling the abraded surface. In a preferred embodiment, the tube 76 is a hypodermic tube and extends to the applicator blade 77. However, any other tubing known in the art that can register with irrigation passage 64 and permit a cooling fluid to be deposited on to the applicator blade 77 may be employed. In an alternate embodiment illustrated in Figures 4b and 5b, the coupler 60 includes a fluid conduit means extending along the coupler axis 66 in the form of an irrigation passage 68, which registers with at least one irrigation passage 73 extending through the connector portion 75 of the applicator and terminating in an outlet 97. This enables a cooling fluid such as water or a saline solution, to flow from the cavity 22, through the fluid conduit means, out of the outlet hole 97 and on to the applicator blade 77, thereby cooling the abraded surface.

The applicator 70 is constructed preferably of 6AL4V Titanium because of its proven acoustic properties and durability. This material is also suitable for contact with human tissue and for operation in a saline environment without degradation. However, any other material known in the art, which has properties similar to those listed for 6AL4V Titanium, may be used. The grain direction of the titanium metal of the applicator 70 is preferably aligned with a longitudinal axis 90 of the applicator 70.

The length of the applicator 70 is prescribed by the acoustic design to be resonant at the selected frequency. The reciprocating motion of the MUT 40 will, at certain harmonic frequencies, generate a standing wave of vibration, which has nodes, corresponding to areas of minimum reciprocating amplitude of displacement, and anti-nodes, corresponding to areas of maximum reciprocating amplitude of displacement. In the preferred embodiment of the invention, the applicator 70 is of a length such that the applicator blade 77 is located at an anti-node.

Referring now to Figs. 6 (a-b) and 7 (a-i), which are side elevations illustrating alternate embodiments for the applicator blade 77, the applicator blade 77 is preferably spatulate in shape and includes a flared portion 78 and a rectangular portion 79.

In the embodiment illustrated in Fig. 7a, the applicator blade 77 is offset from a central axis 90 of the coupler connector portion 75 to enable the SAA 10 to be operated with the handle 20 above the plane of the surface being abraded.

In the embodiment illustrated in Figs. 7b-d, the applicator blade 77 is not offset from the central axis 90 and includes at least one abrading surface 80 and preferably a second abrading surface 81, as illustrated in Figs. 7c-d. The abrading surface 80 may include at least one ridge 84 extending transversely across the abrading surface 80 and defining a ridge abrading surface 88. In the embodiment illustrated in Fig. 7c, the ridge 84 extends transversely across the abrading surface 80, adjacent to an outer edge 86 of the applicator blade 77. In the embodiment illustrated in Fig. 7d, a second ridge 82 extends transversely across the second abrading surface 81 opposite the ridge 84 and defines a second ridge abrading surface 89.

10

In the embodiment illustrated in Figs. 7e-h, the rectangular portion 79 is offset from the central axis 90 to enable the SAA 10 to be operated with the handle 20 above the plane of the surface being abraded. The rectangular portion 79 meets the flared portion 78 at an angle  $\alpha$  of between 90 degrees and 180 degrees relative to the central axis 90. In a preferred embodiment, the rectangular portion 79 meets the flared portion 78 at an angle  $\alpha$  of 150 degrees.

15

In the embodiment illustrated in Figs. 7e-f, the angle  $\alpha$  defines an outer vertex 94, adjacent to which at least one ridge 95 extends and defines a ridge abrading surface 96. Fig. 7f illustrates a preferred embodiment, where the ridge 95 is located on the outer vertex 94.

20

In the embodiment illustrated in Fig. 7g, the applicator blade 77 includes at least one hole 97 extending therethrough for allowing a cooling fluid, such as water or a saline solution, passage therethrough onto the abrading surface 80. Fig. 7h illustrates an embodiment where the at least one hole is a slot 98. In the embodiment illustrated in Fig. 7i, a plurality of holes is located on the applicator blade 77.

25

The present invention is defined by the claims appended hereto, with the foregoing description being illustrative of the preferred embodiments of the invention. Those of ordinary skill may envisage certain additions, deletions and/or modifications to the described embodiments, which, although not explicitly suggested herein, do not depart from the scope of the invention, as defined by the appended claims.

30

**THE EMBODIMENTS OF THE INVENTION IN WHICH AN EXCLUSIVE PROPERTY OR PRIVILEGE IS CLAIMED ARE DEFINED AS FOLLOWS:**

1. A surgical device for use as a skin abrading non-aspirating apparatus, the  
5 apparatus comprising:  
a handle configured for gripping by a human operator;  
a reciprocating motion generator associated with said handle;  
an applicator releasably securable to said handle and having an applicator blade  
for applying abrading motion;  
10 coupler means for coupling said applicator to said reciprocating motion generator  
and for transferring reciprocating motion from said reciprocating motion generator to  
said applicator blade;  
said reciprocating motion generator being a magnetostrictive ultrasonic  
transducer;  
15 said handle having a cavity in an interior thereof, the cavity receiving and  
extending about said magnetostrictive ultrasonic transducer;  
a fluid inlet near one end of said handle, fluidly communicating with said cavity  
for supplying fluid to said cavity from a fluid source;  
a fluid outlet near an opposite end of said handle, fluidly communicating with  
20 said cavity for discharging fluid from said cavity; said magnetostrictive ultrasonic  
transducer further comprising a stack of magnetostrictive laminations insertable into said  
cavity and said cavity includes at least one electronically conducting coil for surrounding  
said stack and inducing an electromagnetic field in said stack in response to electrical  
current flow in said coil, wherein said stack is caused to longitudinally move;  
25 said coupler means mechanically couples said applicator to said stack and said  
apparatus has a fluid conduit means associated with said fluid outlet for directing said  
fluid onto said applicator blade;  
the fluid serving as a cooling fluid, wherein said cooling fluid, cavity and flow of  
said cooling fluid from the fluid inlet end of the cavity, through the cavity and out the fluid  
30 outlet from said cavity removes a heat generated within the cavity of the handle by the  
magnetostrictive ultrasonic transducer to prevent said magnetostrictive ultrasonic  
transducer and handle from overheating;  
said fluid conduit means including at least one irrigation passage extending from  
said cavity and through said coupler; said at least one electronically conducting coil  
35 being connected to an ultrasonic generator capable of generating an electrical current  
having an ultrasonic frequency;

said ultrasonic generator converts a 50 - 60 Hz AC input current into an ultrasonic frequency output current and causes said magnetostrictive ultrasonic transducer to vibrate at ultrasonic frequencies;

5 the skin abrading non-aspirating apparatus further being adapted for use in cosmetic procedures, wherein:

said magnetostrictive ultrasonic transducer is adapted to operate so as to vibrate at a vibrating frequency of between 28 and 32 kHz;

10 said applicator blade is operable so as to have a reciprocating amplitude of vibration of between 12 and 37 microns, said applicator blade being adapted to have an application angle and dimension to minimize or eliminate any flexural mode of the applicator blade; and

15 said skin abrading apparatus further comprises means for eliminating high acoustic losses which would cause excess heating and pose a safety threat to a patient or cause premature fracture or failure, said means being the construction of the applicator blade with titanium material, wherein said titanium material has a grain direction aligned with a longitudinal axis of said applicator blade, and

20 when in use at the operable range of vibrating frequency and reciprocating amplitude of vibration, the apparatus is adapted to be capable of microbrading a stratum corneum of an epidermis without cutting, chopping or cavitating the skin of the patient.

2. The apparatus of claim 1, wherein said magnetostrictive ultrasonic transducer vibrates at a vibrating frequency of 30 kHz.

25 3. The apparatus of claim 1, wherein said applicator blade has a reciprocating amplitude of vibration of 25 microns.

4. The apparatus of claim 1, wherein said magnetostrictive ultrasonic transducer is releasably securable to said handle and said coupler means acts between said stack and said applicator.

30

5. The apparatus of claim 1, wherein said titanium is 6AL4V titanium.

6. The apparatus of claim 1, wherein said applicator includes a connector portion extending from said applicator blade, for securing said applicator to said coupler means.

35

7. The apparatus of claim 6, wherein said fluid conduit means includes at least one irrigation passage extending through said connector portion.

8. The apparatus of claim 1, wherein a standing wave is associated with said reciprocating motion of said applicator, said standing wave having nodes, which correspond to areas of minimum reciprocating amplitude of displacement, and anti-nodes, which correspond to areas of maximum reciprocating amplitude of displacement, wherein said applicator is of a length such that said applicator blade is located at an anti-node.
9. The apparatus of claim 1, wherein said applicator blade includes at least one abrading surface.
10. The apparatus of claim 1, wherein said applicator blade includes two abrading surfaces.
11. The apparatus of claim 9, wherein said at least one abrading surface includes at least one ridge extending transversely across said at least one abrading surface and defining a ridge abrading surface.
12. The apparatus of claim 10, wherein said two abrading surfaces each include at least one ridge extending transversely across each abrading surface and defining respective ridge abrading surfaces.
13. The apparatus of claim 11, wherein said at least one ridge extends transversely across said at least one abrading surface, adjacent to an outer edge.
14. The apparatus of claim 1, wherein said coupler means includes a shaft extending to said applicator blade, said shaft having a central axis, wherein said applicator blade is offset from said central axis to enable said apparatus to be operated with said handle above said plane of said surface being abraded.
15. The apparatus of claim 1, wherein said coupler means includes a shaft extending to said applicator.
16. The apparatus of claim 15, wherein said applicator blade is spatulate in shape.
17. The apparatus of claim 16, wherein said applicator blade includes a flared portion and a rectangular portion.

18. The apparatus of claim 17, wherein said rectangular portion is offset from said central axis to enable said apparatus to be operated with said handle above said plane of said surface being abraded.

5

19. The apparatus of claim 18, wherein said rectangular portion meets said flared portion at an angle of between 90 degrees and 180 degrees relative to said central axis.

20. The apparatus of claim 19, wherein said angle is 150 degrees.

10

21. The apparatus of claim 19, wherein said angle defines an outer vertex, adjacent to which at least one ridge extends and defines a ridge-abrading surface.

15

22. The apparatus of claim 19, wherein said angle defines an outer vertex, on which at least one ridge extends and defines a ridge-abrading surface.

20

23. The apparatus of claim 1, wherein said applicator blade includes at least one hole extending therethrough for allowing fluid passage therethrough onto an underlying surface.

24. The apparatus of claim 23, wherein said at least one hole is a slot.

25. The apparatus of claim 23, wherein said at least one hole is located on said flared portion of said applicator blade.

25

26. An applicator, releasably securable to a handle of a skin abrading apparatus, the applicator including:

30

an applicator blade for applying a reciprocating abrading motion at a vibrating frequency of between 28 and 32 kHz and a reciprocating amplitude of vibration of between 12 and 37 microns, said applicator blade being adapted to have an application angle and dimension to minimize or eliminate any flexural mode of the applicator blade; the applicator blade being made from titanium material, wherein said titanium material has a grain direction aligned with a longitudinal axis of said applicator blade,

35

said applicator having a connector portion extending from said applicator blade, for securing said applicator to a coupler;

said connector portion including a fluid conduit means for directing fluid from a fluid supply onto said applicator blade;

said fluid conduit means includes at least one irrigation passage for extending through said connector portion; and

said applicator blade including at least one hole extending therethrough for allowing fluid passage therethrough onto an underlying surface,

5 wherein a standing wave is associated with said reciprocating motion of said applicator blade, said standing wave having nodes, which correspond to areas of minimum reciprocating amplitude of displacement, and anti-nodes, which correspond to areas of maximum reciprocating amplitude of displacement, wherein said applicator is of a length such that said applicator blade is located at an anti-node, and

10 when the apparatus is in use at the operable range of vibrating frequency and reciprocating amplitude of vibration, the applicator blade is adapted to be capable of microbrading a stratum corneum of an epidermis without cutting, chopping or cavitating the skin of the patient.

15 27. The applicator of claim 26, wherein said titanium is 6AL4V titanium.

28. The applicator of claim 26, wherein said applicator blade includes at least one abrading surface.

20 29. The applicator of claim 26, wherein said applicator blade includes two abrading surfaces.

25 30. The applicator of claim 28, wherein said at least one abrading surface includes at least one ridge extending transversely across said at least one abrading surface and defining a ridge abrading surface.

31. The applicator of claim 29, wherein said two abrading surfaces each include at least one ridge extending transversely across each abrading surface and defining respective ridge abrading surfaces.

30 32. The applicator of claim 30, wherein said at least one ridge extends transversely across said at least one abrading surface, adjacent to an outer edge.

35 33. The applicator of claim 26, wherein said connector portion has a central axis, wherein said applicator blade is offset from said central axis to enable said apparatus to be operated with a shaft above a plane of a skin surface being abraded.

34. The applicator of claim 26, wherein said applicator blade is spatulate in shape.

35. The applicator of claim 34, wherein said applicator blade includes a flared portion and a rectangular portion.

5

36. The applicator of claim 35, wherein said rectangular portion is offset from said central axis to enable said apparatus to be operated with said shaft above said plane of said surface being abraded.

10 37. The applicator of claim 36, wherein said rectangular portion meets said flared portion at an angle of between 90 degrees and 180 degrees relative to said central axis.

38. The applicator of claim 37, wherein said angle is 150 degrees.

15 39. The applicator of claim 37, wherein said angle defines an outer vertex, adjacent to which at least one ridge extends and defines a ridge-abrading surface.

40. The applicator of claim 37, wherein said angle defines an outer vertex, on which at least one ridge extends and defines a ridge-abrading surface.

20

41. The applicator of claim 26, wherein said at least one hole is a slot.

42. The applicator of claim 26, wherein said at least one hole is located on said flared portion of said applicator blade.

25

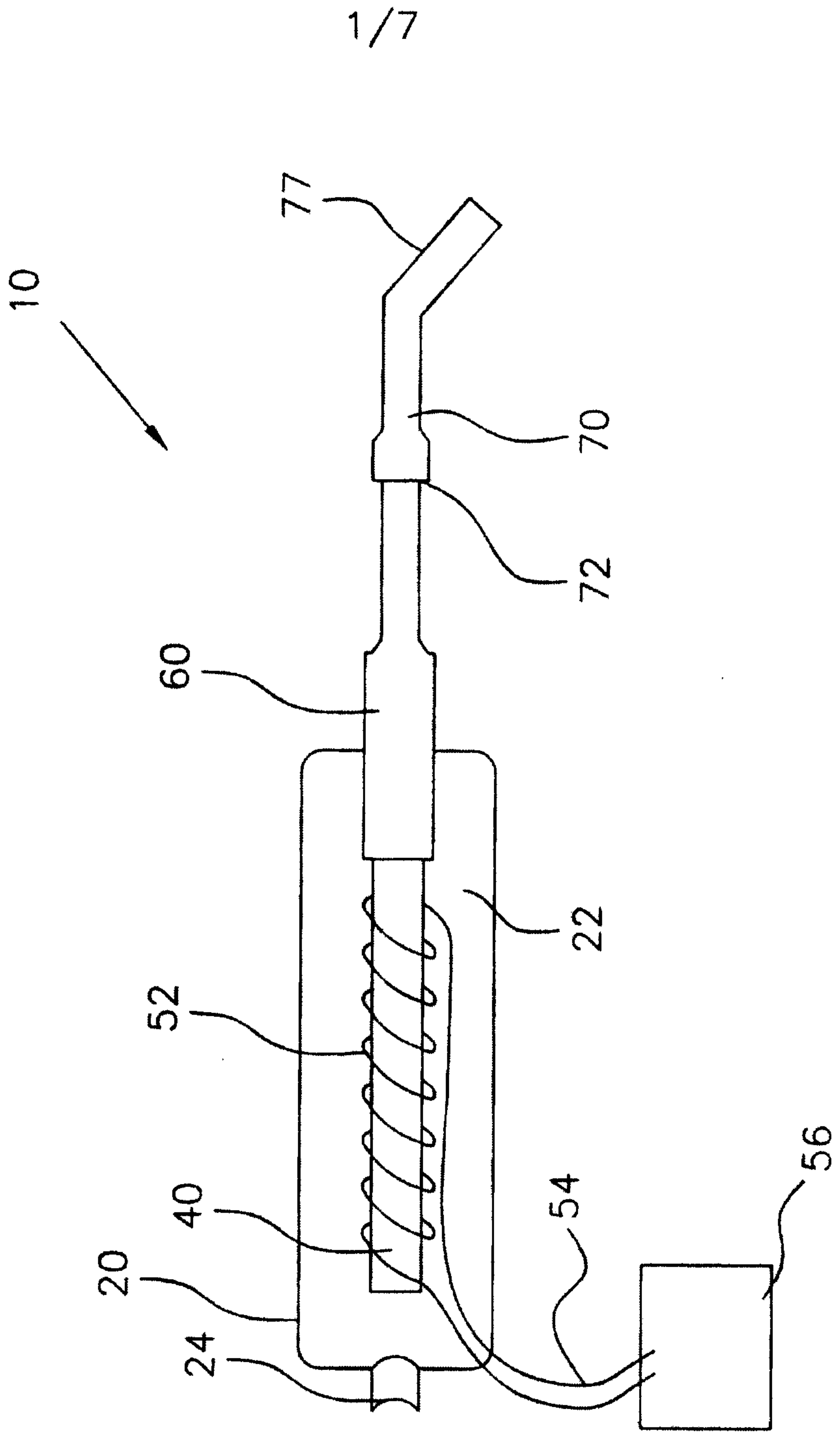

Fig.1

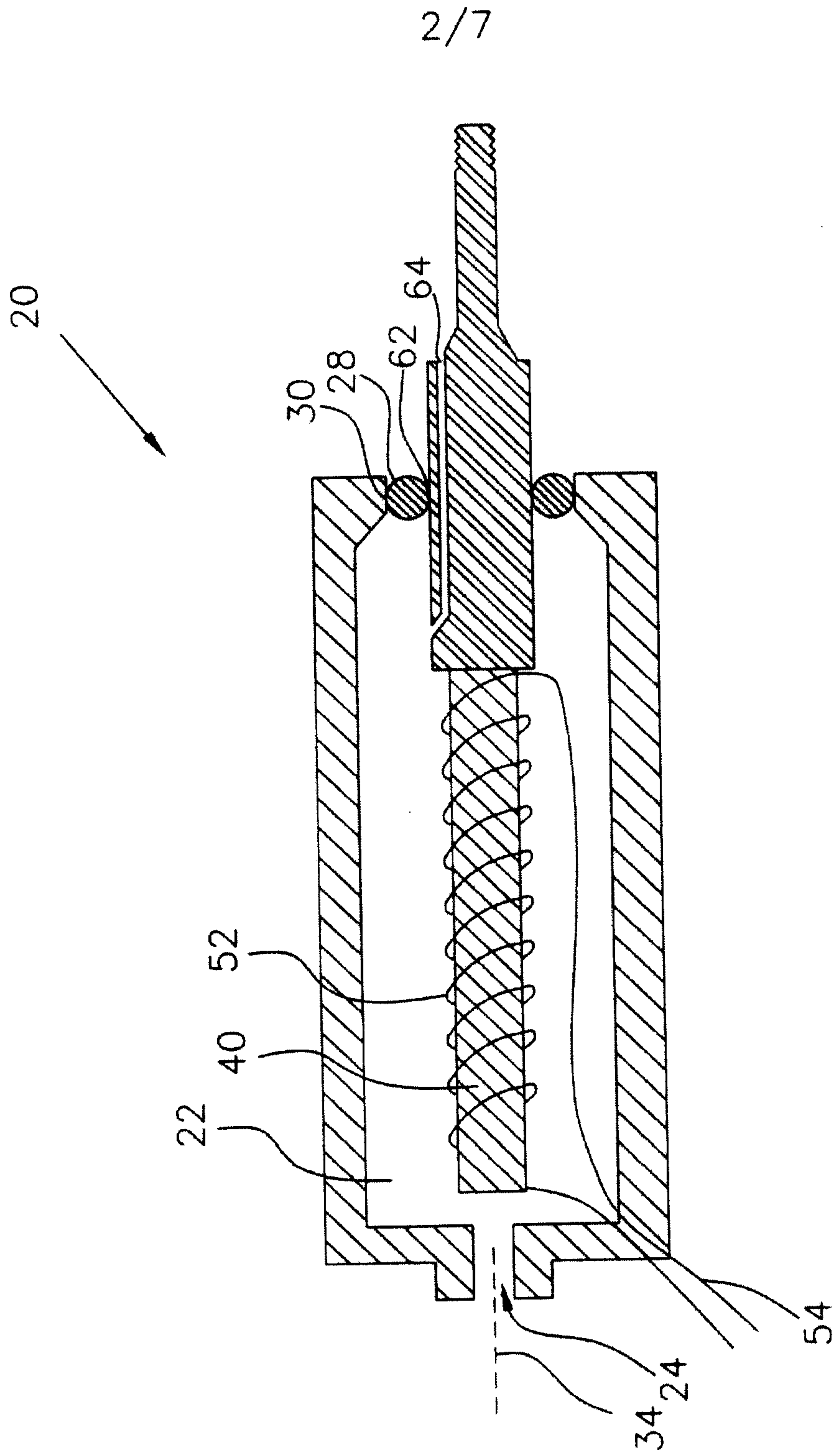

Fig.2

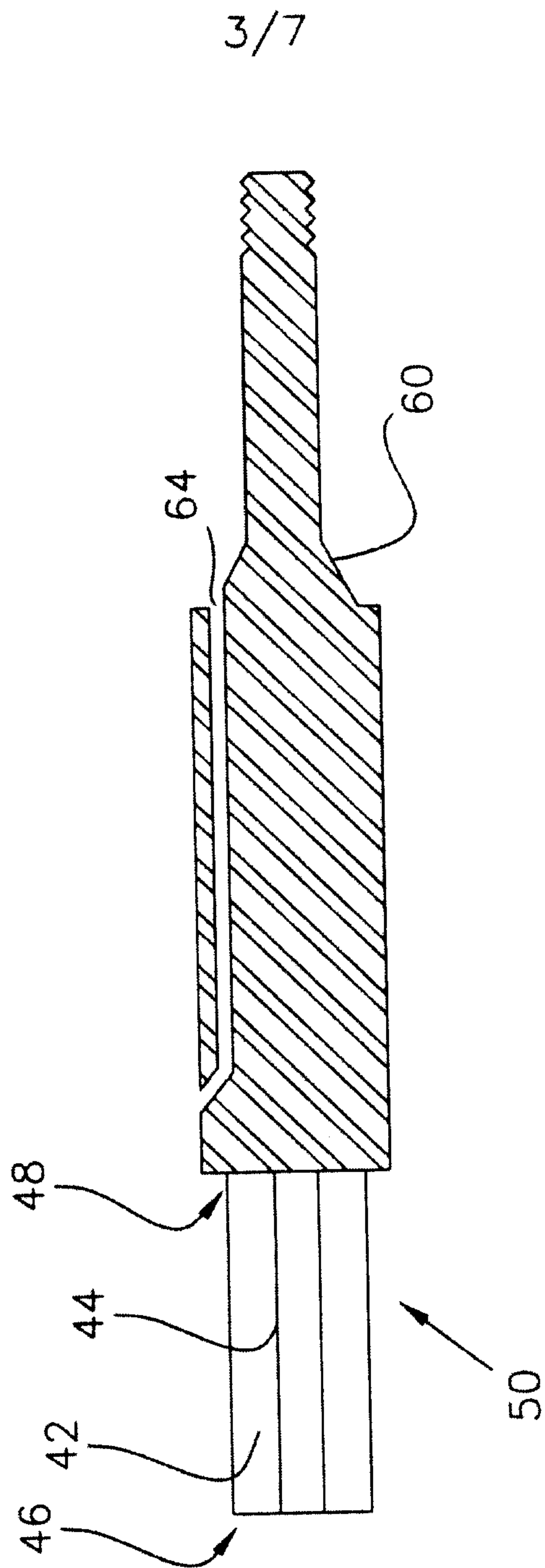

Fig.3

4/7

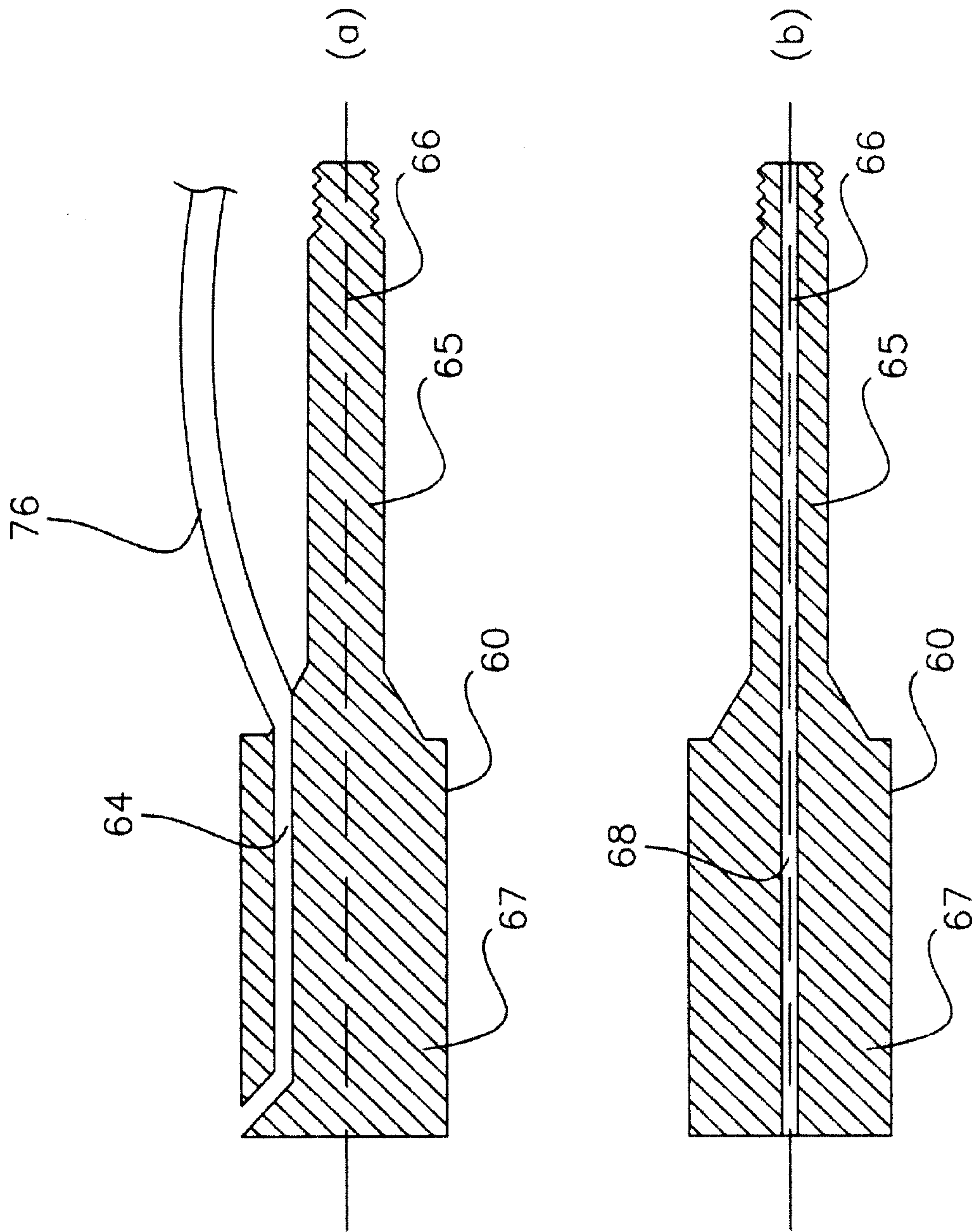

Fig.4

5/7

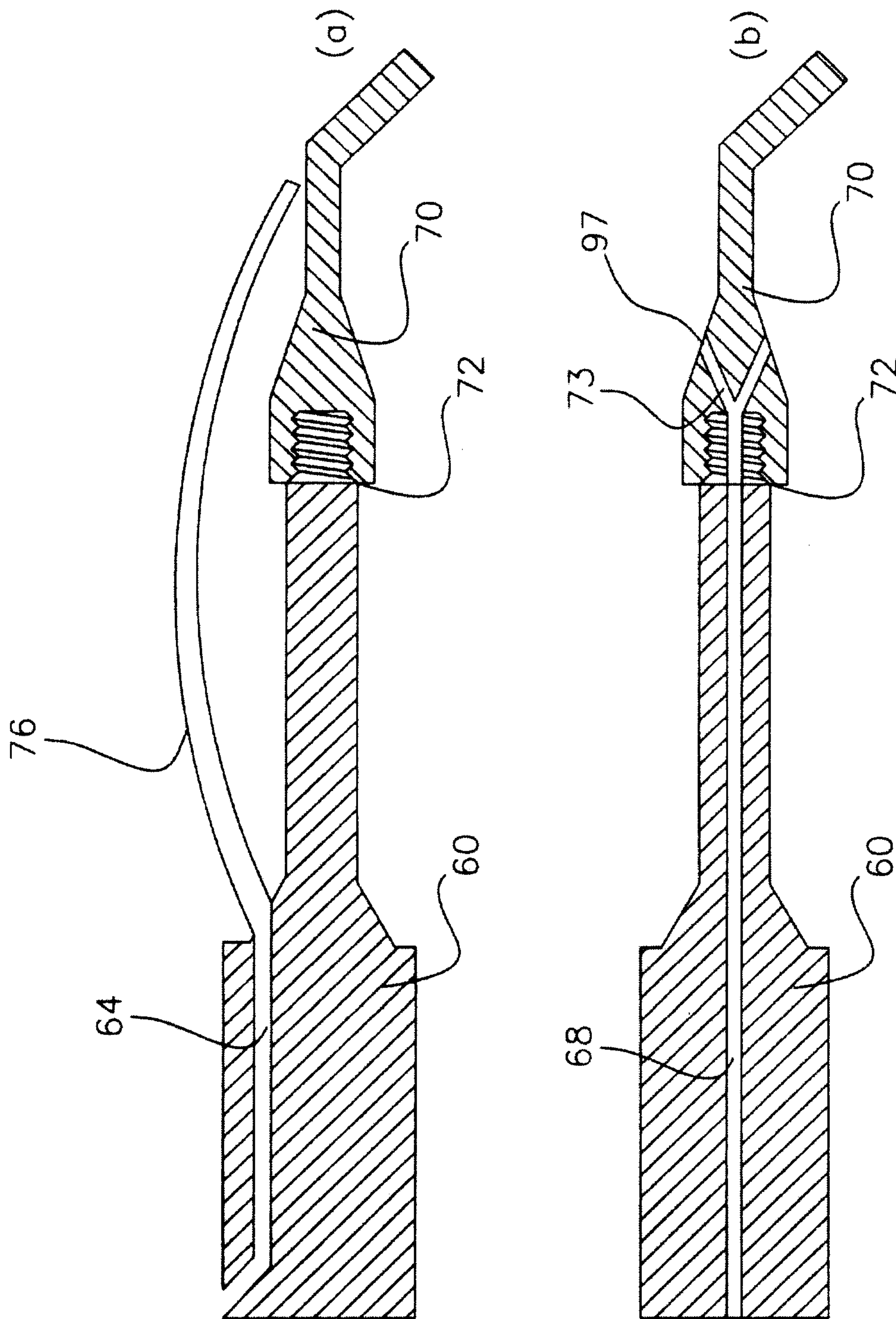

Fig.5

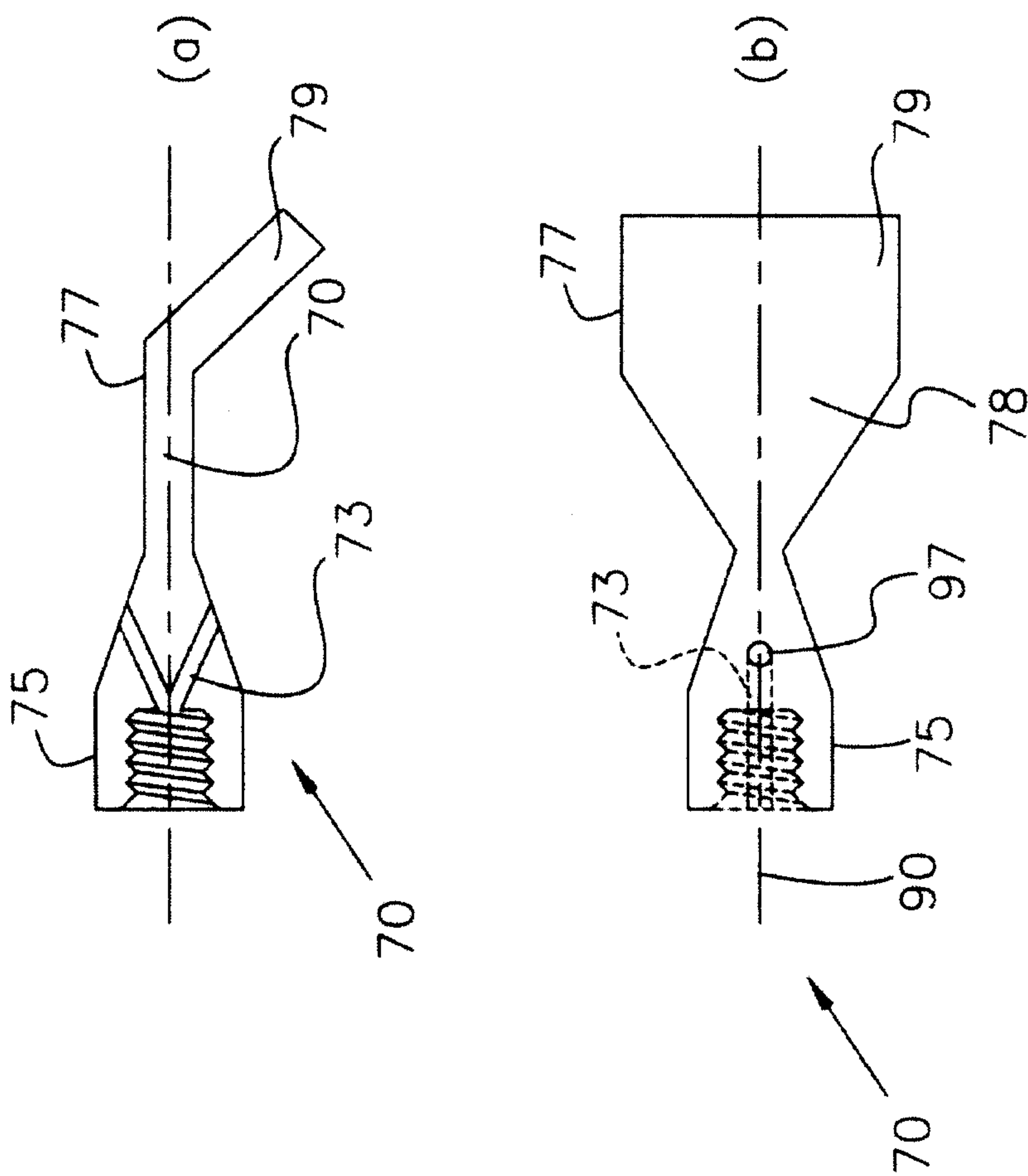

Fig.6



