

L. J. M. BAKER.

Carriage Clip.

No. 72,779.

Patented Dec. 31, 1867.

*Fig. 1.*

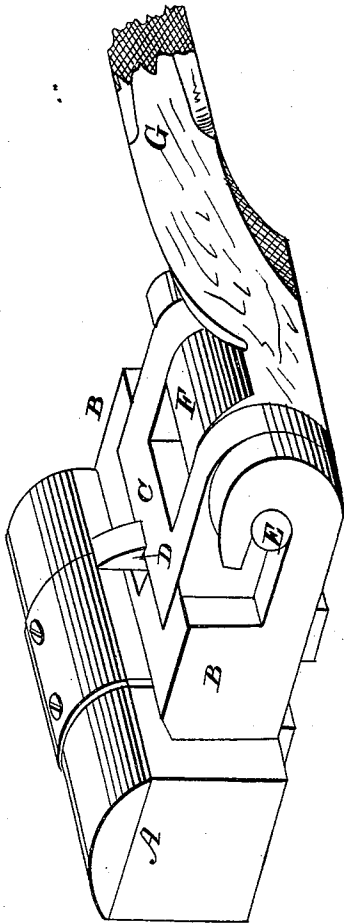

*Fig. 2.*

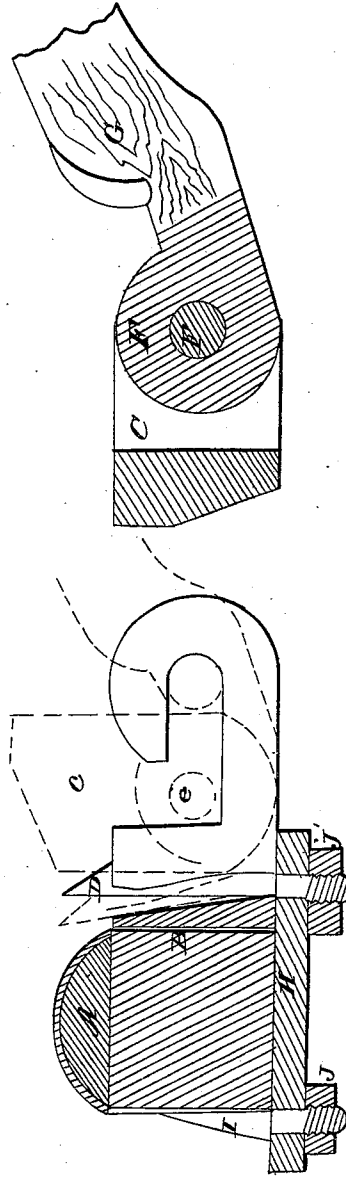

*Attest*  
*John C. Finley*  
*Eyra D. Baker*

*Inventor*  
*L. J. M. Baker.*

# United States Patent Office.

L. J. M. BAKER, OF ENON, OHIO.

Letters Patent No. 72,779, dated December 31, 1867.

## IMPROVEMENT IN CARRIAGE-CLIP.

The Schedule referred to in these Letters Patent and making part of the same.

### TO ALL WHOM IT MAY CONCERN:

Be it known that I, L. J. M. BAKER, of Enon, in the county of Clark, and State of Ohio, have invented a new and useful Improvement in Carriage-Clips; and I do hereby declare the following to be a full, clear, and exact description of the same, reference being had to the accompanying drawings, in which—

Figure 1 is a perspective view of my clip.

Figure 2 is a side elevation of the same, and

Figure 3 is a vertical section through the same.

My invention relates to that class of carriage-clips which render the "shaft" or "pole" capable of removal without unscrewing or removing bolts, &c., and its nature will be understood by reference to the following description.

A is the axle of the wagon, and B is the clip, secured thereto in the usual manner. The projecting lugs B' of the clip are made in the form of hooks, as shown in figs. 1 and 2, the pivot-bolt E being held in the bend of the hook. This construction would permit the shaft-iron to be attached or detached at pleasure, as it could without difficulty be removed from the hooks B'; but, without something to retain said bolt E in place, there would be constant liability that it would be detached. I therefore interpose between the lugs of the clip B and the shaft-iron F the plate C, which has lugs projecting forward on either side of the shaft-iron, and united to it by the pivot-bolt E, which passes through said lugs.

When the shafts are to remain attached to the clip B, and the bolt E has been properly placed in the bend of the hooked lugs B' thereof, the plate C is turned down so that it is wholly between said lugs, as shown in fig. 1, and effectually prevents the shaft-iron and the joint-bolt E from moving backward, so as to be detached from the clip; and the plate C is securely held in this position by the spring-latch D, which is attached permanently to the clip, as shown in fig. 2.

When the shafts are to be detached, the spring-latch D is pressed back, so that the plate C can be turned up, as shown by red lines in fig. 2, and the shaft-iron and bolt E can then be slid back far enough to be free from the hooks B', and detached.

Having thus described my invention, what I claim as new, is—

The combination of the shaft-iron F, plate C, bolt E, and hooks B', substantially as and for the purpose set forth.

The combination of the plate C and spring D, substantially as and for the purpose set forth.

L. J. M. BAKER.

Witnesses:

WM. T. HILL,  
D. ZEIGLER.