

July 3, 1934.

C. A. SCHLACHTER

1,965,005

LOCK FOR REVOLVING DOORS

Filed Nov. 20, 1931

3 Sheets-Sheet 1

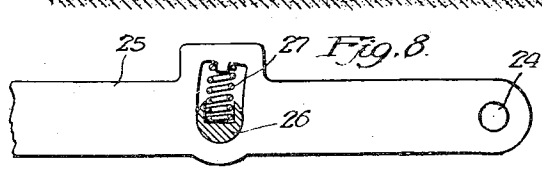
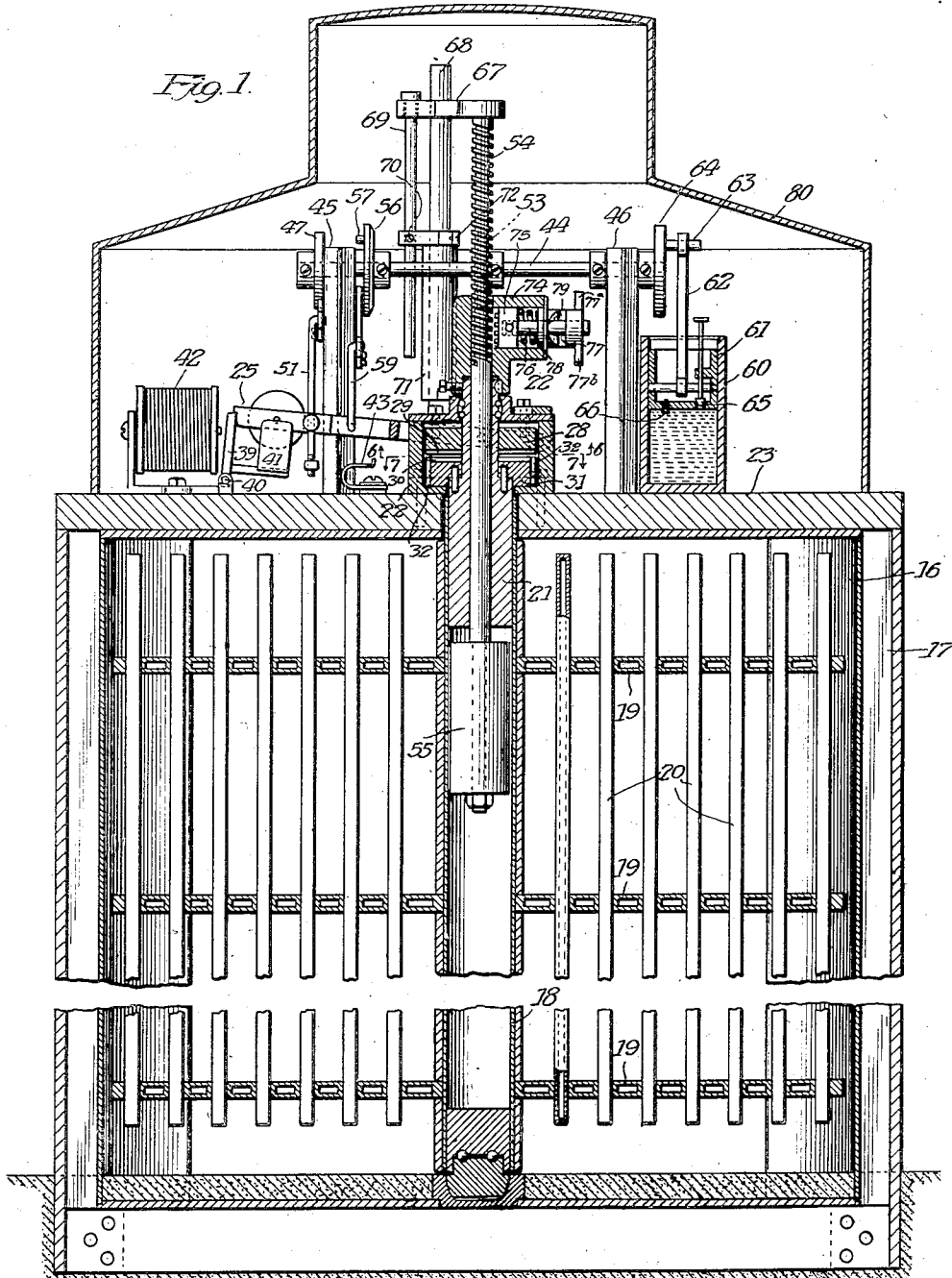

Inventor  
Carl A. Schlachter  
By *Wm. H. ...*  
Att'y's

July 3, 1934.

C. A. SCHLACHTER

1,965,005

LOCK FOR REVOLVING DOORS

Filed Nov. 20, 1931

3 Sheets-Sheet 2

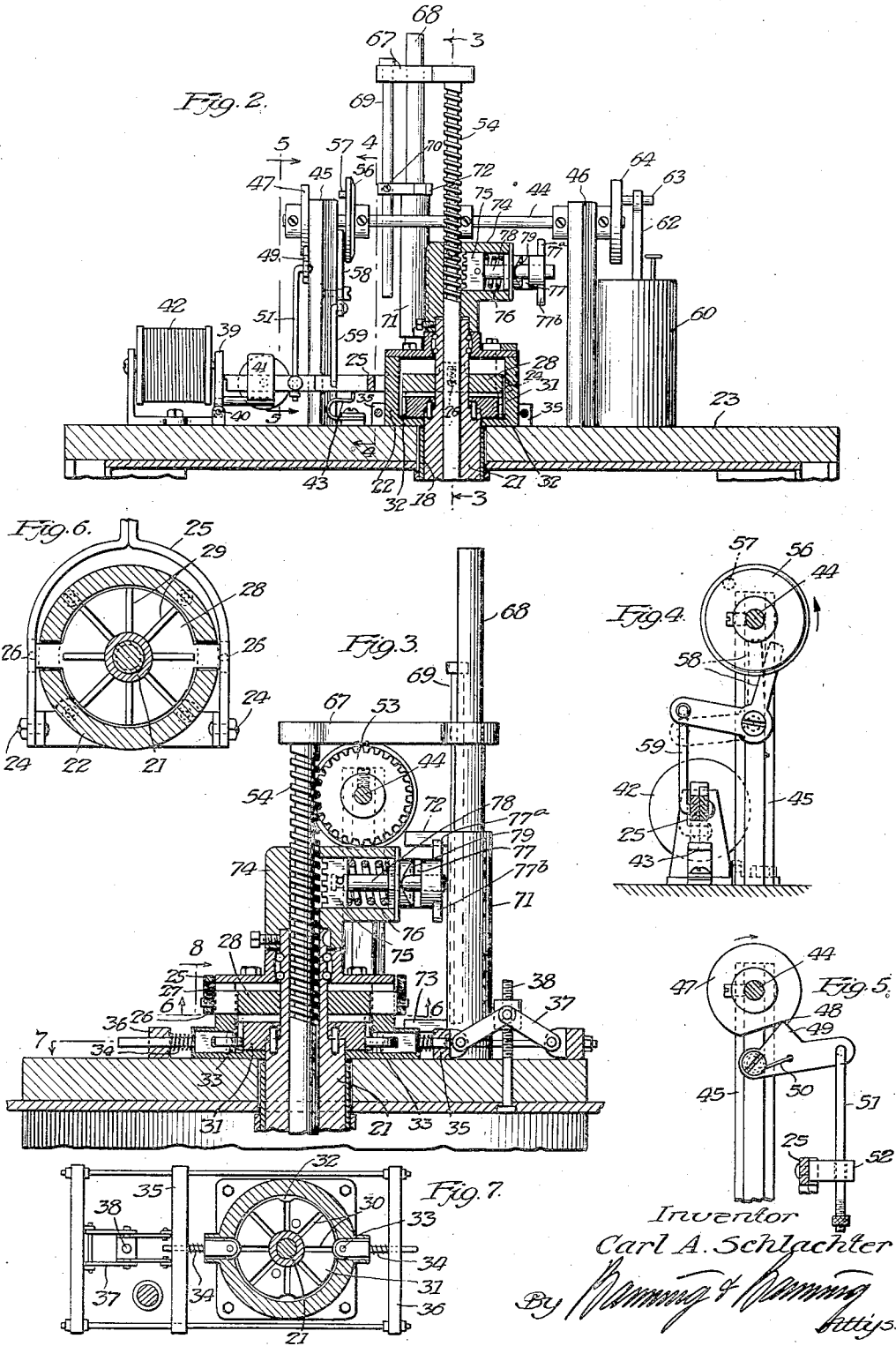

Inventor  
Carl A. Schlachter  
By *Manning & Manning*  
Attys

July 3, 1934.

C. A. SCHLACHTER

1,965,005

LOCK FOR REVOLVING DOORS

Filed Nov. 20, 1931

3 Sheets-Sheet 3

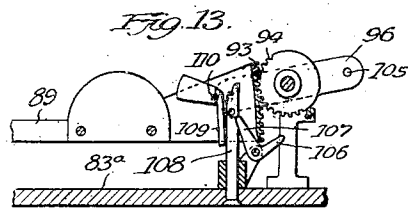
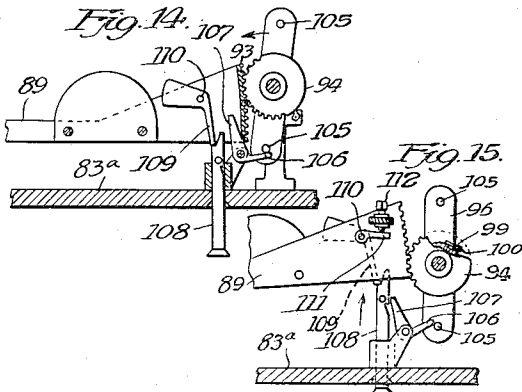
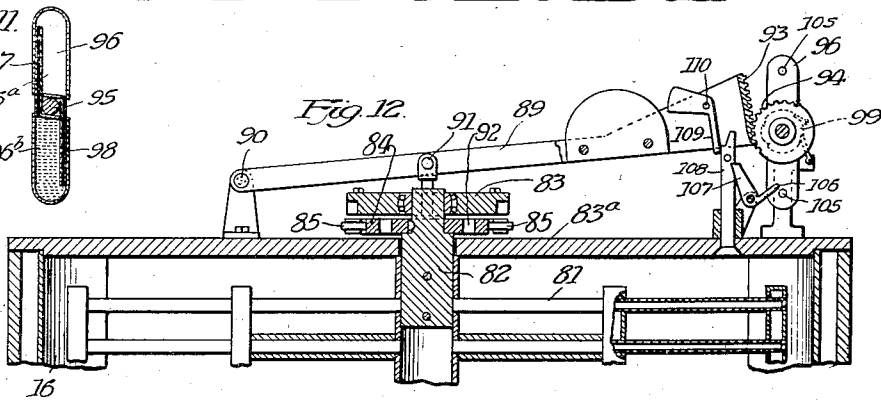
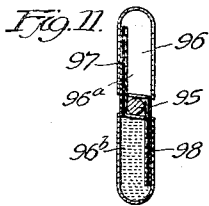
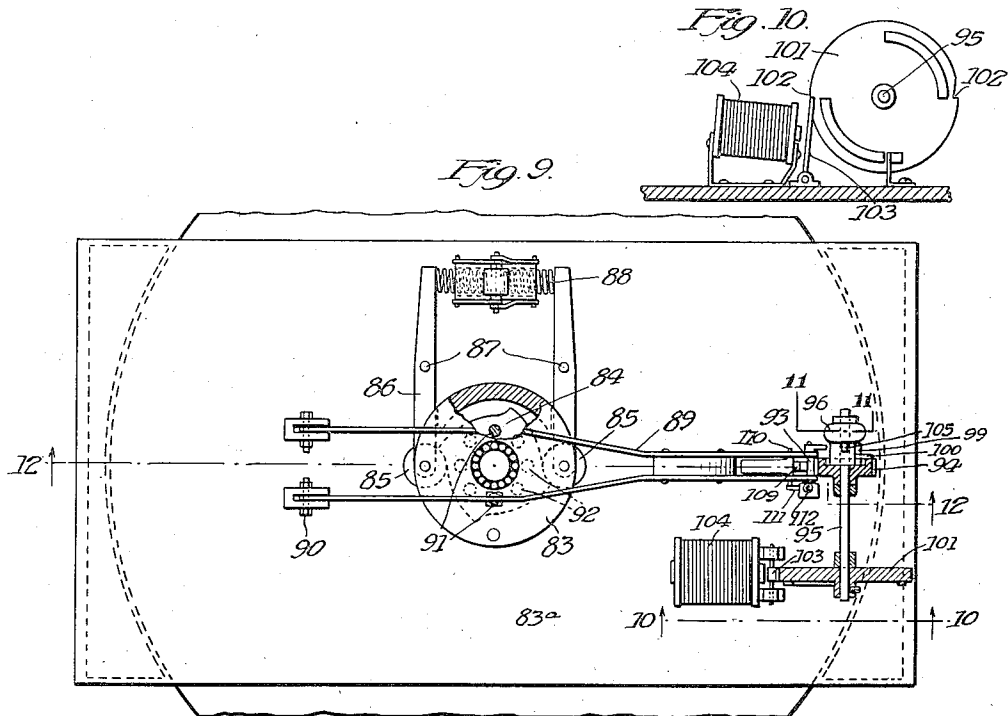

Inventor  
Carl A. Schlachter  
By *Hanning & Hanning*  
Attys

# UNITED STATES PATENT OFFICE

1,965,005

## LOCK FOR REVOLVING DOORS

Carl A. Schlachter, Rockwell City, Iowa, assignor  
of one-half to John E. Gustin, Fort Dodge,  
Iowa

Application November 20, 1931, Serial No. 576,411

8 Claims. (Cl. 70—50)

A primary object of this invention is to provide means for locking the door of a bank, or the like, in case of a robbery, the locking being adapted to be done from one or more points in the bank.

Another object is to provide means to prevent tampering with the door while it is locked.

Another object is to provide means for releasing the door, either manually or automatically, after a predetermined time interval has elapsed after it has been thus locked.

These and other objects, as will hereinafter appear, are accomplished by this invention which is fully described in the following specification and shown in the accompanying drawings, in which—

Figure 1 is a vertical section through a revolving door embodying the invention showing the locking and resetting mechanism in the normal inoperative position;

Fig. 2 is a similar view showing this mechanism in the first stage of the locked position;

Fig. 3 is a partial enlarged section on the line 3 of Fig. 2 showing the door locked, but with a weight member descended with the resetting mechanism in position to be operated;

Figs. 4 and 5 are partial enlarged views on the lines 4 and 5 respectively of Fig. 2;

Figs. 6 and 7 are horizontal sections as viewed on the lines 6 and 7 respectively of Fig. 1;

Fig. 8 is an enlarged partial detail of the trunnion mounting in the weight lever;

Fig. 9 is a top plan view partly in section showing the operating mechanism of a modified form of the invention;

Fig. 10 is a partial vertical section on the line 10 of Fig. 9 showing the electrical releasing mechanism;

Fig. 11 is a vertical section on the line 11 of Fig. 9 showing a timing device;

Fig. 12 is a partial vertical section on the line 12—12 of Fig. 9 showing the mechanism in the normal inoperative position;

Fig. 13 is a partial view of the operating mechanism of Fig. 12 showing the same immediately after the door has been locked;

Fig. 14 is a similar view showing the mechanism after the door has been released and preparatory to manually resetting the mechanism; and

Fig. 15 is a similar view of the same mechanism showing the mechanism in the process of being reset.

The embodiment illustrated in Figs. 1 to 8 inclusive comprises a vertically disposed cylindrical shell 16 which is set in the wall 17 of a building, and serves to enclose a revolving door A which is made up of a centrally disposed tube or hollow shaft 18 upon which is mounted a series of arms 19 which are preferably made in the form of an X, with the arms extending at 90° so as to carry a series of vertical members 20, which are preferably tubular in form, these tubes and the arms 19 being hollow so as to carry a highly inflammable material, such as gasoline or benzine, so as to prevent their being readily cut as by means of a blow torch or oxy-acetylene flame. Or these hollow members may be filled with tear gas, or the like, for the same purpose.

The hollow shaft 18 is suitably mounted on roller bearings at the bottom, and at the top carries a hollow stub shaft 21 which has a reduced end provided with a suitable ball bearing, which is carried by a housing 22 and supported upon the framework 23 of the top of the door, to which it is rigidly secured by means of bolts.

### *Mechanism for locking the door*

On the outside of the housing 22, as shown in Figs. 1 and 6, and pivotally connected thereto by means of bolts 24, is a bifurcated lever 25, in the sides of which are journaled trunnions 26 which are adapted to turn slightly therein, but which are yieldably held by means of springs 27. These trunnions are connected to a disc 28 (Fig. 6) which has in its lower face a series of downwardly extending teeth 29 which are adapted to engage in a series of notches 30 in a lower disc 31, which is keyed to the stub shaft 21, the disc 28 being freely rotatable thereon.

The lower disc is provided with a series of peripheral depressions 32 (Fig. 7) which are adapted to be engaged by opposed rollers 33 which are pressed inwardly by means of springs 34, which are urged inwardly by opposing yolks 35, 36, which are controlled by means of a toggle 37 which is adjustably operated by means of an adjusting screw 38 to vary the pressure of the rollers 33.

The lever 25 is normally held in a raised position by means of a detent 39 pivotally mounted at 40, as shown in Fig. 1, the detent having a counterweight 41 the detent serving also as an armature for a solenoid 42. This solenoid may be actuated on the closing of a switch (not shown) by a suitable source of electric energy, which may be located at some remote point, such as the cashier's cage, so that in case of an attempted robbery the cashier on operating this switch may cause the detent 39 to be withdrawn, as shown in Fig. 2,

thereby lowering the lever 25 and closing the dental clutch comprising the discs 28 and 31, thus causing the revolving door to be locked during the time these dental clutch members are in engagement.

It is desirable that the mechanism for operating the door and for locking it be completely enclosed so as to prevent its being tampered with, and for this reason it is necessary that some means be provided for automatically unlocking the door after a predetermined interval—say fifteen minutes—which would be sufficient to permit the police force to arrive. This mechanism will now be described.

#### *Unlocking mechanism*

A shaft 44 is suitably journaled in standards 45, 46, and has keyed thereon a circular member 47 (Fig. 5) which has a shoulder 48 adapted to be engaged by a pawl 49 which is normally held in engagement by means of a spring 50. The pawl carries a rod 51 which slides loosely through an ear 52 on the lever 25. When, therefore, the lever 25 drops, the pawl 49 is withdrawn and the shaft 44 is then free to rotate in a clockwise direction, as will now be explained.

A worm wheel 53 (Fig. 3) is keyed on the shaft 44 and engages a screw 54 which does not rotate since it is keyed to a member 67, but is slidable through the hollow stub shaft 21, and carries a weight 55, as shown in Fig. 1. This weight normally tends to rotate the shaft 44 through the worm wheel 53, but is prevented by means of the pawl 49. On withdrawing the pawl, as has been described, the weight thus tends to rotate the shaft 44 in a clockwise direction, as viewed in Fig. 5. This shaft carries a crank 56 which has a pin 57 (Fig. 4) which on being rotated is adapted to engage one arm of a bell crank 58, the other arm being connected by means of a rod 59 with the lever 25. Thus when the crank is rotated the pin moves the upper arm of the bell crank from the dotted line position to the full line position, thereby raising the lever 25 from the position of Fig. 2 to that of Fig. 1, where it will again be held by the detent 39.

It is desirable, however, that this action shall take place slowly, whereas if left to itself it would act very quickly. This is accomplished by means of a dash pot 60 in which slides a tightly fitting piston 61, to which is pivotally secured a connecting rod 62 which takes hold of a pin 63 on a crank 64, which is keyed to the shaft 44. The piston 61 has an adjustable needle valve 65 adjustably closing and opening in the bottom of the piston, which also has a check-valve 66. This piston overlies a body of oil, or a like fluid, in the bottom of the dash pot, the needle valve permitting this fluid to pass slowly up into the interior of the piston as it is lowered under the action of the weight. The check-valve 66 permits the fluid within the piston to pass down rapidly when the piston is again raised, as will later be described.

#### *Resetting mechanism*

Having thus described how the door is locked and later unlocked, it now becomes necessary to show how the weight mechanism is returned to the elevated position of Fig. 1.

The screw 54 has a member 67 rigidly secured thereto at its upper end, this member being slidably mounted on a rod 68 which is mounted on the framework 23. The member 67 has an opening through which is loosely slidable a rod 69, which is adjustably secured by means of a

screw 70 to a tube 71 which is slidable on the rod 68. This tube carries upper and lower stops 72, 73, respectively, which serve to reverse the resetting mechanism.

A hollow element 74 is secured to the upper end of the stub shaft 21 and encloses a sliding nut 75, which is normally pressed toward the screw 54 by means of a spring 76 and which is movable into and out of engagement with the screw by means of a cam follower 77, which is carried by an extension 78 of the nut, the cam follower being rotatable through about 90° with respect to the extension 78, and operating upon the face of a cam 79.

When the nut 75 is in engagement with the screw 54, the latter will be raised as the nut 75 is turned by the rotation of the door A in the usual direction. As soon, therefore, as the door is unlocked the resetting mechanism is in the position shown in Fig. 3, and the cam follower 77 has an upwardly extending ear 77<sup>a</sup> which on the first revolution of the door engages the upper stop 72, thereby operating as a star wheel to throw the cam follower to the low side of the cam, thereby bringing the nut into engagement with the screw 54.

The continued rotation of the door will then cause the screw to be fed upwardly, thereby returning the shaft 44 and its associated parts to the position shown in Fig. 1, or a little beyond. When this point is reached the lower extending ear 77<sup>b</sup> of the star wheel will engage the lower stop 73, thereby causing the cam follower 77 to ride up on the cam 79 and withdrawing the nut 75 from engagement with the screw 54. Thus the parts are returned to their original position. While these parts will be enclosed within the building, a cover 80 may be used as a protection against dust and dirt.

Thus it will be seen that a very efficient means is provided whereby a cashier in his cage in a bank may, by pressing a button, lock the doors of the bank, sound an alarm, and simultaneously notify the police in case he thinks that the bank is about to be robbed. At the same time means is provided to prevent the robbers from cutting their way through the revolving door, as by means of a blow torch. The material of the door itself may be such as would prevent the bars from being sawed, as where it is specially tempered or case hardened.

In Figs. 9 to 15, inclusive, is shown a modified form of the device for which the resetting mechanism is manually operated. This consists of a revolving door 81 having a stub shaft 82 at the upper end journaled in a suitable housing 83, which is firmly secured to the top member 83<sup>a</sup> and having keyed thereon a cam 84 upon which, from opposite sides, bear cam rollers 85 which are carried upon the ends of levers 86 pivotally mounted at 87, and pressed outwardly by means of springs 88 so as to cause the rollers to bear firmly on the cam. This acts as a brake against its being revolved in the usual right-hand direction, so as to tend to stop the door where it will engage pins 91. A bifurcated lever 89 is pivotally mounted at 90, each side of the lever pivotally carrying a pin 91 which extends through the stationary housing 83, but are normally raised as shown in Fig. 12 so as to be held out of engagement with the cam 84. This cam, however, has a series of holes 92 which are adapted to engage the lower ends of the pins 91 when the latter are lowered, as will later be explained, so as to lock the door to prevent it from being ro-

tated until these pins are again raised out of engagement with the cam.

The lever 89 has a gear sector 93 which engages a gear 94 which is keyed to a shaft 95. This shaft has mounted thereon a hollow container 96 having two compartments 96<sup>a</sup> and 96<sup>b</sup> adapted to hold a liquid, such as mercury, the two compartments being connected by means of two tubes 97, 98, the purpose of which will later be described. This container is secured to a ratchet 99 which is rotatably mounted on the shaft 95 and which has a series of teeth adapted to be engaged by a pawl 100, which is pivotally carried on the side of the gear 94.

Thus the ratchet and the container 96 are free to revolve in a counterclockwise direction, as shown in Fig. 12, with respect to the gear 94, but will not revolve in the opposite direction when the gear reverses. The shaft 95 carries a disc 101 which has two notches 102 in its periphery which are adapted to be engaged by a spring-pressed pawl 103, and normally held in the position shown in Fig. 10. A solenoid 104 stands immediately in front of the pawl, and when actuated draws the pawl to one side so as to permit the disc 101 to rotate in a counterclockwise direction. The solenoid 104 may be connected through a suitable source of electric energy, and one or more push buttons or switches which, as described in the other form, may be placed in any desired point, such as in the cashier's cage of a bank so that in case of a threatened robbery he may actuate the solenoid to lock the door, and at the same time this same circuit may be used to sound an alarm or to throw an indicator in the nearest police station. The circuit for doing this is not illustrated, but its operation will be apparent to anyone versed in this art.

On actuating the solenoid 104 the pawl 103 is withdrawn from the notch 102, and the weight of the lever 89 will cause it to descend, thereby causing the pins 91 to drop into engagement with the next two holes 92 which come into engagement therewith as the door is rotated. When this happens the container 96 will be rocked over into the position shown in Fig. 13. The liquid which was previously in the bottom compartment of the container is now elevated slightly above horizontal, and will run slowly through one of the tubes 97, 98, to the lower compartments. When enough of it has run over to overcome friction this container will then rock through, as shown in Fig. 14, and the lowermost pin 105 on the side of the container will engage a finger 106 on the pawl 107 and will cause it to be rotated slightly in a clockwise direction, thereby disengaging it from the plunger 108 with which it was engaged, as shown in Figs. 12 and 13.

This plunger then drops by gravity and passes down beneath the weighted pawl 109 which is secured to a shaft 110, which is journaled in the lever 89. The lever can now be moved back to the position of Fig. 12 by pressing upwardly on the plunger 108, as shown in Fig. 15. As it approaches the top point of its swing a short lever 111 secured to the shaft 110 engages the end of an adjustable screw 112, and kicks the lower end of the pawl 109 out of engagement with the end of the plunger 108. When this occurs the parts have returned to the position shown in Fig. 12, and the revolving door is again free to swing as before.

Immediately following the energization of the solenoid the revolving door becomes locked and remains locked until the container 96 slowly pours

its liquid contents from the upper compartment to the lower. The speed with which this occurs will depend largely upon the amount of liquid present, its viscosity, and the size of the tube through which it passes. These may be varied to suit various desired conditions, but should be long enough to insure help arriving before the door is released.

While I have shown and described but a few embodiments of my invention, it is to be understood that it is capable of many modifications. Changes, therefore, in the construction and arrangement may be made which do not depart from the spirit and scope of the invention as disclosed in the appended claims.

I claim:

1. In mechanism for controlling a revolving door, means movable vertically to lock the door, a member movable by its own weight for returning the locking means to its normal inoperative position, means for retarding the action of the weight, and means operable by the rotation of the door for returning the weight to its normal elevated position.

2. In mechanism for controlling a revolving door, means movable vertically to lock the door, mechanism including a member having a screw-threaded stem movable by its own weight to return the locking means to its normally inoperative position, and a nut adapted to be moved into engagement with the screw-threaded stem when the stem has descended to a predetermined level, said nut being rotatable by the door to return said stem and weight to their normal inoperative position.

3. In mechanism for controlling a revolving door, means movable vertically to lock the door, mechanism including a member having a screw-threaded stem movable by its own weight to return the locking means to its normally inoperative position, and a nut movable with the door and adapted to be moved into engagement with the screw-threaded stem when the stem has descended to a predetermined level, said nut being rotatable by the door to return said stem and weight to their normal inoperative position.

4. In mechanism for controlling a revolving door, means movable vertically to lock the door, a shaft operatively connected to the locking means and having a worm wheel, a screw-threaded weight member movable by its own weight to turn said shaft to return the locking means to its normally inoperative position.

5. In mechanism for controlling a revolving door, means movable vertically to lock the door, a shaft operatively connected to the locking means and having a worm wheel, a screw-threaded weight member movable by its own weight to turn said shaft to return the locking means to its normally inoperative position, and means movable into engagement with the screw by the rotation of the door to return the weight member to its normally inoperative position.

6. In mechanism for controlling a revolving door, means movable vertically to lock the door, a shaft operatively connected to the locking means and having a worm wheel, a screw-threaded weight member movable by its own weight to turn said shaft to return the locking means to its normally inoperative position, and cam-operated means movable into engagement with the screw by the rotation of the door to return the weight member to its normally inoperative position.

7. In mechanism for controlling a door adapted to revolve on a hollow shaft about a vertical axis,

5

10

15

20

25

30

35

40

45

50

55

60

65

70

75

80

85

90

95

100

105

110

115

120

125

130

135

140

145

150

means movable vertically to lock the door, a shaft  
 operatively connected to the locking means and  
 having a worm wheel, a weight member having  
 a screw extending upwardly axially through the  
 5 hollow shaft and movable by said weight to turn  
 said shaft to return the locking means to its nor-  
 mally inoperative position, and cam-operated  
 means movable into engagement with the screw  
 by the rotation of the door to return the weight  
 10 member to its normally inoperative position.

8. In mechanism for controlling a door adapted  
 to revolve on a hollow shaft about a vertical

axis, means movable vertically to lock the door,  
 a shaft operatively connected to the locking  
 means and having a worm wheel, a weight mem-  
 ber movable within the hollow shaft and having  
 a screw extending upwardly axially through the  
 80 hollow shaft and movable by said weight to turn  
 said shaft to return the locking means to its nor-  
 mally inoperative position, and cam-operated  
 means movable into engagement with the screw  
 by the rotation of the door to return the weight  
 85 member to its normally inoperative position.

CARL A. SCHLACHTER.

15	90
20	95
25	100
30	105
35	110
40	115
45	120
50	125
55	130
60	135
65	140
70	145
75	150