

(19) World Intellectual Property Organization
International Bureau



(43) International Publication Date
11 December 2003 (11.12.2003)

PCT

(10) International Publication Number
WO 03/103064 A1

- (51) International Patent Classification⁷: **H01L 33/00**
- (21) International Application Number: PCT/US03/12122
- (22) International Filing Date: 5 May 2003 (05.05.2003)
- (25) Filing Language: English
- (26) Publication Language: English
- (30) Priority Data:
10/156,810 29 May 2002 (29.05.2002) US
- (71) Applicant: **OPTOLUM, INC.** [US/US]; 4115 North 62nd Street, Scottsdale, AZ 85251 (US).
- (72) Inventor: **DRY, Joel, M.**; 1457 Calhoun Street, New Orleans, LA 70118 (US).
- (74) Agents: **GITLER, Stewart, L.** et al.; Hoffman, Wasson & Gitler, P.C., Suite 522, 2361 Jefferson Davis Highway, Arlington, VA 22202 (US).
- (81) Designated States (*national*): AE, AG, AL, AM, AT, AU, AZ, BA, BB, BG, BR, BY, BZ, CA, CH, CN, CO, CR, CU, CZ, DE, DK, DM, DZ, EC, EE, ES, FI, GB, GD, GE, GH, GM, HR, HU, ID, IL, IN, IS, JP, KE, KG, KP, KR, KZ, LC, LK, LR, LS, LT, LU, LV, MA, MD, MG, MK, MN, MW, MX, MZ, NO, NZ, OM, PH, PL, PT, RO, RU, SC, SD, SE, SG, SK, SL, TJ, TM, TN, TR, TT, TZ, UA, UG, UZ, VC, VN, YU, ZA, ZM, ZW.
- (84) Designated States (*regional*): ARIPO patent (GH, GM, KE, LS, MW, MZ, SD, SL, SZ, TZ, UG, ZM, ZW), Eurasian patent (AM, AZ, BY, KG, KZ, MD, RU, TJ, TM), European patent (AT, BE, BG, CH, CY, CZ, DE, DK, EE, ES, FI, FR, GB, GR, HU, IE, IT, LU, MC, NL, PT, RO, SE, SI, SK, TR), OAPI patent (BF, BJ, CF, CG, CI, CM, GA, GN, GQ, GW, ML, MR, NE, SN, TD, TG).
- Published:**
— with international search report

[Continued on next page]

(54) Title: LIGHT EMITTING DIODE LIGHT SOURCE

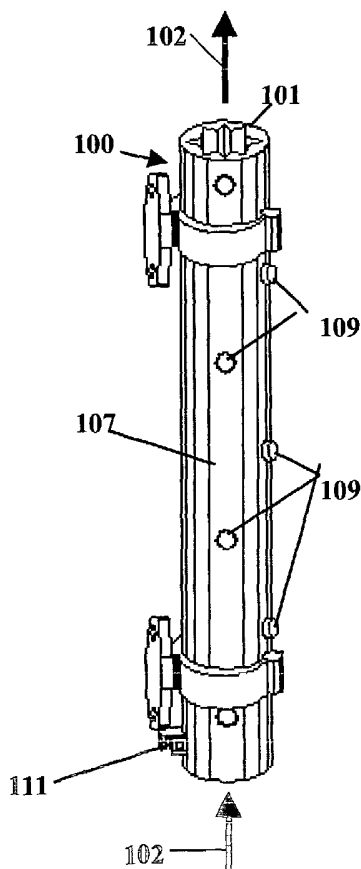

(57) Abstract: The present invention relates to a light source that utilizes light emitting diodes (109) that emit white light. The diodes are mounted on an elongated member (101) having at least two surfaces upon which the light emitting diodes are mounted. The elongate member is thermally conductive and is utilized to cool the light emitting diodes. In the illustrative embodiment, the elongate member is a tubular member through which a heat transfer medium flows.



WO 03/103064 A1



For two-letter codes and other abbreviations, refer to the "Guidance Notes on Codes and Abbreviations" appearing at the beginning of each regular issue of the PCT Gazette.

LIGHT EMITTING DIODE LIGHT SOURCE

Field of the Invention:

[0001] This invention pertains to lighting sources, in general, and to a lighting source that utilizes Light Emitting Diodes (LED's), in particular.

BACKGROUND OF THE INVENTION

[0002] LED's have many advantages as light sources. However, in the past LED's have found application only as specialized light sources such as for vehicle brake lights, and other vehicle related lighting, and recently as flashlights. In these prior applications, the LED's are typically mounted in a planar fashion in a single plane that is disposed so as to be perpendicular to the viewing area. Typically the LED planar array is not used to provide illumination, but to provide signaling.

[0003] Recent attempts to provide LED light sources as sources of illumination have been few, and generally unsatisfactory from a general lighting standpoint.

[0004] It is highly desirable to provide a light source utilizing LED's that provides sufficient light output so as to be used as a general lighting source rather than as a signaling source.

[0005] One problem that has limited the use of LED's to specialty signaling and limited general illumination sources is that LED's typically generate significant amounts of heat. The heat is such that unless the heat is dissipated, the LED internal temperature will rise causing degradation or destruction of the LED.

[0006] It is therefore further desirable to provide an LED light source that efficiently conducts heat away from the LED's.

SUMMARY OF THE INVENTION

[0007] In accordance with the principles of the invention, an improved light source is provided. The light source includes an elongate thermally conductive member having an outer surface. A plurality of light emitting diodes is carried on the elongate member outer surface. At least some of the light emitting diodes are disposed in a first plane and others of said light emitting diodes are disposed in a second plane not coextensive with the first plane. Electrical conductors are carried by the elongate thermally conductive member and are connected to the plurality of light emitting diodes to supply electrical power thereto. The elongate thermally conductive member conducts heat away from the light emitting diodes.

[0008] In accordance with one aspect of the invention, an illustrative embodiment of the invention utilizes light emitting diodes that emit white light. However, other embodiments of the invention may utilize light emitting diodes that are of different colors to produce monochromatic light or the colors may be chosen to produce white light or other colors.

[0009] In accordance with another aspect of the invention the elongate thermally conductive member transfers heat from the light emitting diodes to a medium within said elongate thermally conductive member. In the illustrative embodiment of the invention, the medium is air.

[0010] In accordance with another aspect of the invention, the elongate thermally conductive member has one or more fins to enhance heat transfer to the medium.

[0011] In accordance with another aspect of the invention the elongate thermally conductive member comprises a tube. In one embodiment of the invention, the tube has a cross-section in the shape of a polygon. In another embodiment of the invention, the tube has a cross-section having flat portions.

[0012] In accordance with another embodiment of the invention, the elongate thermally conductive member comprises a channel.

-3-

[0013] In accordance with the principles of the invention, the elongate thermally conductive member may comprise an extrusion, and the extrusion can be highly thermally conductive material such as aluminum.

[0014] In one preferred embodiment of the invention the elongate thermally conductive member is a tubular member. The tubular member has a polygon cross-section. However, other embodiments may have a tubular member of triangular cross-section.

[0015] In one embodiment of the invention, a flexible circuit is carried on a surface of said elongate thermally conductive member; the flexible circuit includes the electrical conductors.

[0016] In another aspect of the invention, the flexible circuit comprises a plurality of apertures for receiving said plurality of light emitting diodes. Each of the light emitting diodes is disposed in a corresponding one of the apertures and affixed in thermally conductive contact with said elongate thermally conductive member.

[0017] The elongate thermally conductive member includes a thermal transfer media disposed therein in a flow channel.

[0018] At least one clip for mounting the elongate thermally conductive member in a fixture may be included.

BRIEF DESCRIPTION OF THE DRAWING

[0019] The invention will be better understood from a reading of the following detailed description of a preferred embodiment of the invention taken in conjunction with the drawing figures, in which like reference indications identify like elements, and in which:

[0020] **FIGURE 1** is a planar side view of a light source in accordance with the principles of the invention;

[0021] **FIGURE 2** is a top planar view of the light source of Figure 1;

[0022] **FIGURE 3** is a perspective view of the light source of Figure 1 with mounting clips;

[0023] **FIGURE 4** is a planar side view of the light source of Figure 3 showing mounting clips separated from the light source;

[0024] **FIGURE 5** is a top view of the light source and mounting clips of Figure 4; and

[0025] **FIGURE 6** is a partial cross-section of the light source of Figure 1.

DETAILED DESCRIPTION

[0026] A light source in accordance with the principles of the invention may be used as a decorative lighting element or may be utilized as a general illumination device. As shown in Figure 1, a light source 100 in accordance with the invention includes an elongate thermally conductive member or heat sink 101. Elongate heat sink 101 is formed of a material that provides excellent thermal conductivity. Elongate heat sink 101 in the illustrative embodiment of the invention is a tubular aluminum extrusion. To improve the heat dissipative properties of light source 100, elongate heat sink 101 is configured to provide convective heat dissipation and cooling. As more clearly seen in Figure 2, tubular heat sink 101 is hollow and has an interior cavity 103 that includes one or more heat dissipating fins 105. Fins 105 are shown as being triangular in shape, but may take on other shapes. Fins 105 are integrally formed on the interior of elongate heat sink 101. In the illustrative embodiment convective cooling is provided by movement of a medium 102 through elongate heat sink 101. The medium utilized in the illustrative embodiment is air, but may in some applications be a fluid other than air to provide for greater heat dissipation and cooling.

[0027] The exterior surface 107 of elongate heat sink 101 has a plurality of Light Emitting Diodes 109 disposed thereon. Each LED 109 in the illustrative embodiment comprises a white light emitting LED of a type that provides a high light output. Each LED 109 also generates significant amount of heat that must be dissipated to avoid thermal destruction of the LED. By combining a plurality of LEDs 109 on elongate heat sink 101, a high light output light source that may be used for general lighting is provided.

[0028] Conductive paths 129 are provided to connect LEDs 109 to an electrical connector 111. The conductive paths may be disposed on an electrically insulating layer 131 or layers disposed on exterior surface 107. In the illustrative embodiment shown in the drawing figures, the conductive paths and insulating

-6-

layer are provided by means of one or more flexible printed circuits 113 that are permanently disposed on surface 107. As more easily seen in Figure 6, printed circuit 113 includes an electrically insulating layer 131 that carries conductive paths 129. As will be appreciated by those skilled in the art, other means of providing the electrically conductive paths on the

[0029] Flexible printed circuit 113 has LED's 109 mounted to it in a variety of orientations ranging from 360 degrees to 180 degrees and possibly others depending on the application. Electrical connector 111 is disposed at one end of printed circuit 113. Connector 113 is coupleable to a separate power supply to receive electrical current. Flexible printed circuit 113, in the illustrative embodiment is coated with a non-electrically conductive epoxy that may be infused with optically reflective materials. Flexible printed circuit 113 is adhered to the tube 101 with a heat conducting epoxy to aid in the transmission of the heat from LEDs 109 to tube 101. Flexible printed circuit 113 has mounting holes 134 for receiving LEDs 109 such that the backs of LEDs 109 are in thermal contact with the tube surface 107.

[0030] Tubular heat sink 101 in the illustrative embodiment is formed in the shape of a polygon and may have any number of sides. Although tubular heat sink 101 in the illustrative embodiment is extruded aluminum, tubular heat sink 101 may comprise other thermal conductive material. Fins 105 may vary in number and location depending on particular LED layouts and wattage. In some instances, fins may be added to the exterior surface of tubular heat sink 101. In addition, apertures may be added to the tubular heat sink to enhance heat flow.

[0031] Light source 100 is mounted into a fixture and retained in position by mounting clips 121, 123 as most clearly seen in Figures 3, 4, and 5. Each of the clips is shaped so as to engage and retain light source 100. Each clip is affixed on one surface 122, 124 to a light fixture.

[0032] Although light source 100 is shown as comprising an elongate tubular heat sink, other extruded elongate members may be used such as channels.

[0033] In the illustrative embodiment shown, convection cooling by flow of air through tubular heat sink 101 is utilized such that cool or unheated air enters tubular heat sink 101 at its lower end and exits from the upper end as heated air. In higher wattage light sources, rather than utilizing air as the cooling medium, other fluids may be utilized. In particular, convective heat pumping may be used to remove heat from the interior of the heat sink.

[0034] In one particularly advantageous embodiment of the invention, the light source of the invention is configured to replace compact fluorescent lighting in decorative applications.

[0035] As will be appreciated by those skilled in the art, the principles of the invention are not limited to the use of light emitting diodes that emit white light. Different colored light emitting diodes may be used to produce monochromatic light or to produce light that is the combination of different colors.

[0036] Although the invention has been described in terms of illustrative embodiments, it is not intended that the invention be limited to the illustrative embodiments shown and described. It will be apparent to those skilled in the art that various changes and modifications may be made to the embodiments shown and described without departing from the spirit or scope of the invention. It is intended that the invention be limited only by the claims appended hereto.

WHAT IS CLAIMED IS:

1. A light source comprising:
 - an elongate thermally conductive member having an outer surface;
 - a plurality of light emitting diodes carried on said elongate member outer surface at least some of said light emitting diodes being disposed in a first plane and others of said light emitting diodes being disposed in a second plane not coextensive with said first plane;
 - electrical conductors carried by said elongate thermally conductive member and connected to said plurality of light emitting diodes to supply electrical power thereto; and
 - said elongate thermally conductive member being configured to conduct heat away from said light emitting diodes to fluid contained by said elongate thermally conductive member.
2. The light source in accordance with claim 1, wherein each of said light emitting diodes emits white light.
3. The light source in accordance with claim 1, wherein said fluid comprises air.
4. The light source in accordance with claim 1, wherein said elongate thermally conductive member comprises one or more heat dissipation protrusions.
5. The light source in accordance with claim 1, wherein said elongate thermally conductive member comprises a tube.
6. The light source in accordance with claim 5, wherein said tube has a cross-section in the shape of a polygon.
7. The light source in accordance with claim 5, wherein said tube has a cross-section having flat portions.

8. The light source in accordance with claim 1, wherein said elongate thermally conductive member comprises a channel.

9. The light source in accordance with claim 1, wherein said elongate thermally conductive member comprises an extrusion.

10. The light source in accordance with claim 9, wherein said extrusion is an aluminum extrusion.

11. The light source in accordance with claim 10, wherein said elongate thermally conductive member is a tubular member.

12. The light source in accordance with claim 11, wherein said tubular member has a polygon cross-section.

13. The light source in accordance with claim 11, wherein said tubular member has a triangular cross-section.

14. The light source in accordance with claim 1, comprising a flexible circuit carried on a surface of said elongate thermally conductive member, said flexible circuit comprising said electrical conductors.

15. The light source in accordance with claim 14, wherein said flexible circuit comprises a plurality of apertures for receiving said plurality of light emitting diodes.

16. The light source in accordance with claim 15, wherein each of said light emitting diodes is disposed in a corresponding one of said apertures and affixed in thermally conductive contact with said elongate thermally conductive member.

17. The light source in accordance with claim 1, wherein a thermal transfer media disposed therein.

-10-

18. The light source in accordance with claim 17, wherein said elongate thermally conductive member comprises a flow channel for said thermal transfer media.

19. The light source in accordance with claim 1, comprising at least one clip for mounting said elongate thermally conductive member in a fixture.

20. The light source in accordance with claim 1, comprising an electrically insulating layer disposed on said elongate thermally conductive member outer surface and carrying said electrical conductors thereon.

21. The light source in accordance with claim 20, wherein said electrically insulating layer comprises a plurality of apertures, each aperture receiving one of said light emitting diodes; and each light emitting diode of said plurality of light emitting diodes being mounted in a corresponding one of said apertures and in thermally conductive contact with said elongate thermally conductive member.

22. The light source in accordance with claim 21, wherein each of said light emitting diodes emits white light.

23. A light source comprising:

an elongate thermally conductive member having an outer surface;

at least one light emitting diodes carried on said elongate member outer surface;

one or more electrical conductors carried by said elongate thermally conductive member and connected to said at least one light emitting diodes to supply electrical power thereto; and

said elongate thermally conductive member being configured to conduct heat away from said at least one light emitting diode to fluid contained by said elongate thermally conductive member.

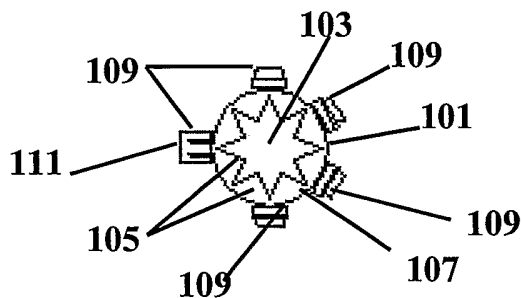

FIG. 2

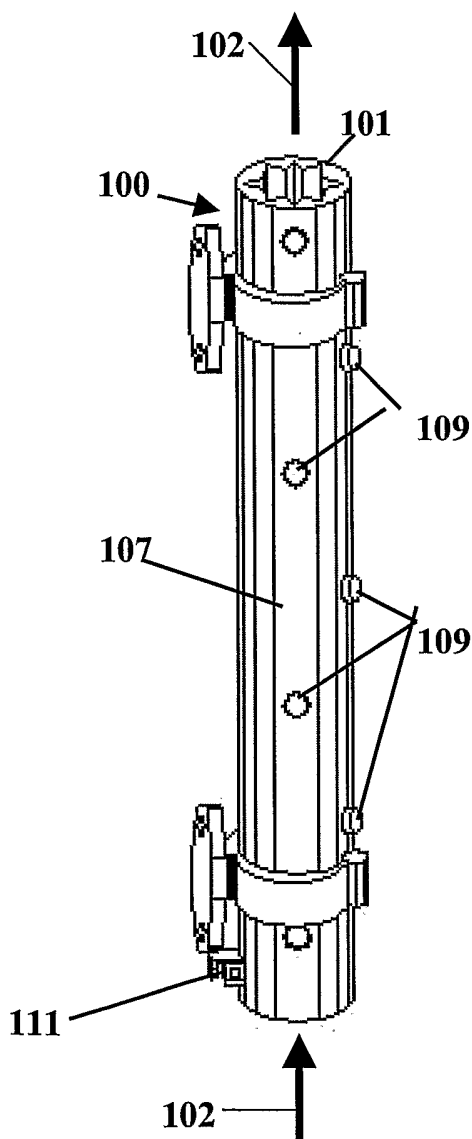

FIG. 3

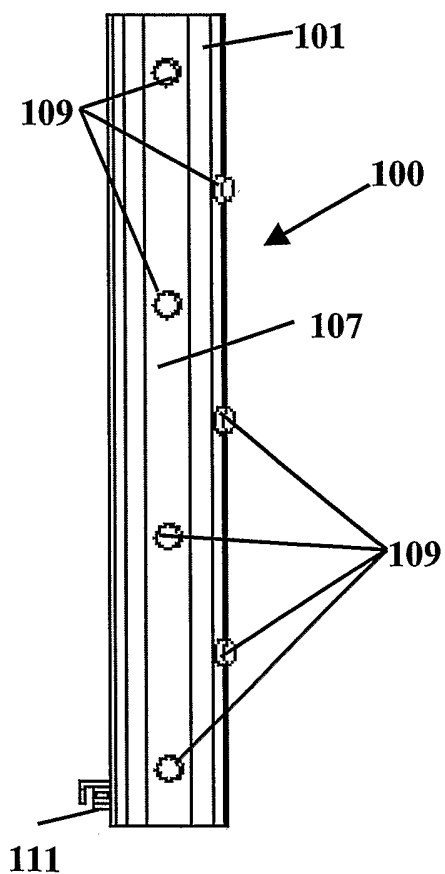

FIG. 1

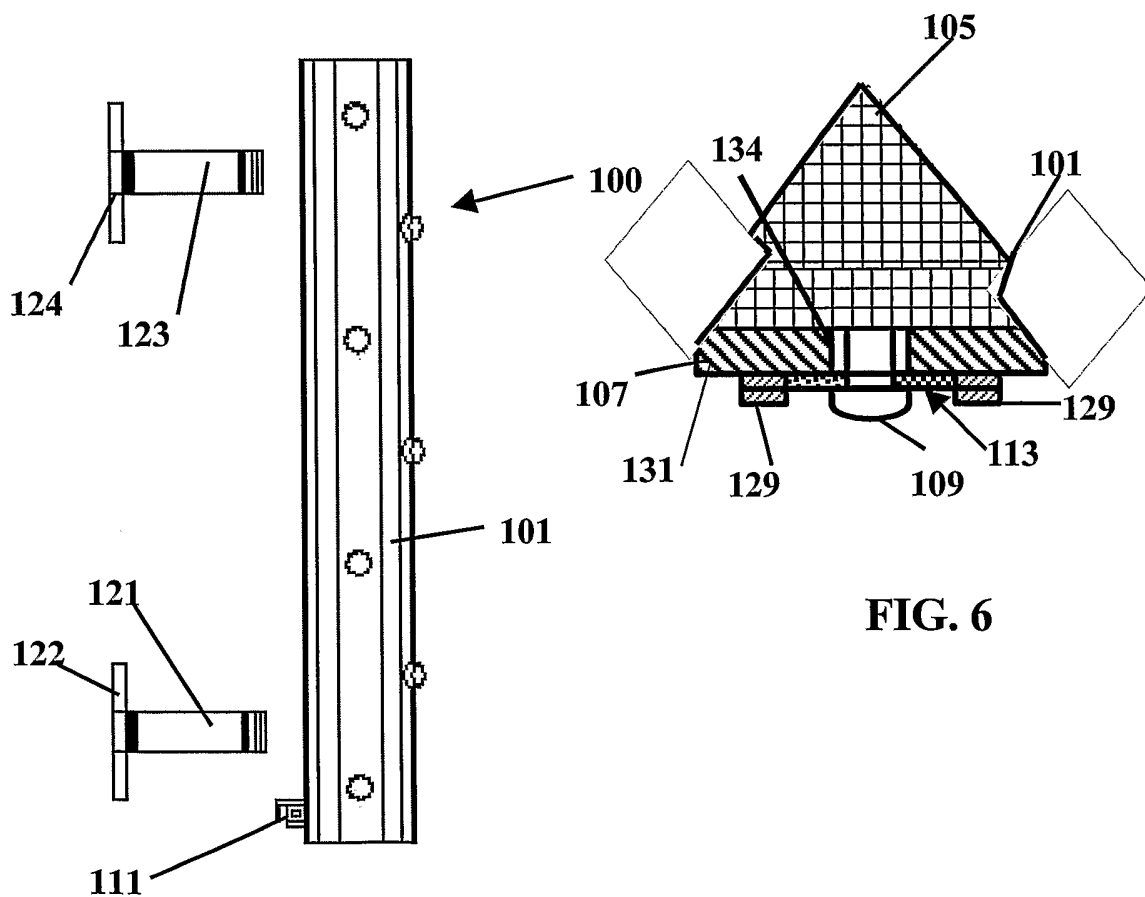
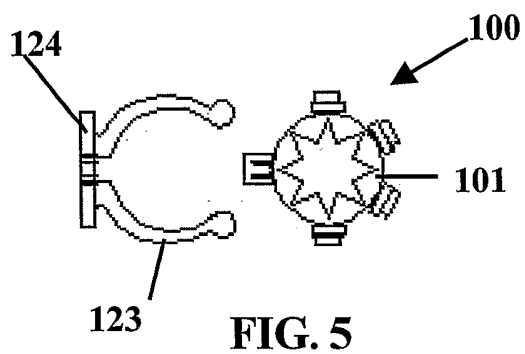

FIG. 6

INTERNATIONAL SEARCH REPORT

International application No.
PCT/US03/12122

| | | |
|---|--|---|
| A. CLASSIFICATION OF SUBJECT MATTER | | |
| IPC(7) : H01L 33/00 US CL : 257/88; 362/555 | | |
| According to International Patent Classification (IPC) or to both national classification and IPC | | |
| B. FIELDS SEARCHED | | |
| Minimum documentation searched (classification system followed by classification symbols) U.S. : 257/88; 362/555 | | |
| Documentation searched other than minimum documentation to the extent that such documents are included in the fields searched | | |
| Electronic data base consulted during the international search (name of data base and, where practicable, search terms used) Please See Continuation Sheet | | |
| C. DOCUMENTS CONSIDERED TO BE RELEVANT | | |
| Category * | Citation of document, with indication, where appropriate, of the relevant passages | Relevant to claim No. |
| A , P | US 2003/0063463 A1 (SLOAN et al.) 03 April 2003 (03.04.2003), see Figure 1. | 1-23 |
| A , P | US 2002/0191396 A1 (REIFF et al.) 19 December 2002 (19.12.2002), Figures 2 and 15. | 1-23 |
| <input type="checkbox"/> Further documents are listed in the continuation of Box C. | | <input type="checkbox"/> See patent family annex. |
| * Special categories of cited documents: | "T" later document published after the international filing date or priority date and not in conflict with the application but cited to understand the principle or theory underlying the invention | |
| "A" document defining the general state of the art which is not considered to be of particular relevance | "X" document of particular relevance; the claimed invention cannot be considered novel or cannot be considered to involve an inventive step when the document is taken alone | |
| "E" earlier application or patent published on or after the international filing date | "Y" document of particular relevance; the claimed invention cannot be considered to involve an inventive step when the document is combined with one or more other such documents, such combination being obvious to a person skilled in the art | |
| "L" document which may throw doubts on priority claim(s) or which is cited to establish the publication date of another citation or other special reason (as specified) | "&" document member of the same patent family | |
| "O" document referring to an oral disclosure, use, exhibition or other means | | |
| "P" document published prior to the international filing date but later than the priority date claimed | | |
| Date of the actual completion of the international search 04 June 2003 (04.06.2002) | Date of mailing of the international search report 10 SEP 2003 | |
| Name and mailing address of the ISA/US Commissioner of Patents and Trademarks Box PCT Washington, D.C. 20231 Facsimile No. (703)305-3230 | Authorized officer Tu-Tu Ho <i>Dian Smute f</i> Telephone No. (703) 305-0086 | |

INTERNATIONAL SEARCH REPORT

International application No.

PCT/US03/12122

Continuation of B. FIELDS SEARCHED Item3:

EAST, ("Hochstein peter".in. and ((led light near emitting)
) ((((((led light near emitting)
) with (flashlight flash adj light)) and ((heatsink ((heat thermal\$2) near (sink spread\$3 dissipat\$3 conducting conductive radiating))
(cool\$3 adj device))
)) and (elongat\$3 tub\$4)) (((elongat\$3 tub\$4) near9 (plural\$3 near2 ((led light near emitting)
) and ((heatsink ((heat thermal\$2) near (sink spread\$3 dissipat\$3 conducting conductive radiating)) (cool\$3 adj device))
) ((((((led light near emitting)
) with ((different (first near US-20020191396-A1.DID. second)) near2 (plane surface))) same (elongat\$3 tub\$4) and ((heatsink
((heat thermal\$2) near (sink spread\$3 dissipat\$3 conducting conductive radiating)) (cool\$3 adj device))
) (((plural\$3 near2 ((led light near emitting)
) with ((different (first near US-20020191396-A1.DID. second)) near2 (plane surface))) and ((heatsink ((heat thermal\$2) near
(sink spread\$3 dissipat\$3 conducting conductive radiating)) (cool\$3 adj device))
))) (((exit adj sign) (led adj sign) and ((led light near emitting)
) and ((heatsink ((heat thermal\$2) near (sink spread\$3 dissipat\$3 conducting conductive radiating)) (cool\$3 adj device))
))