

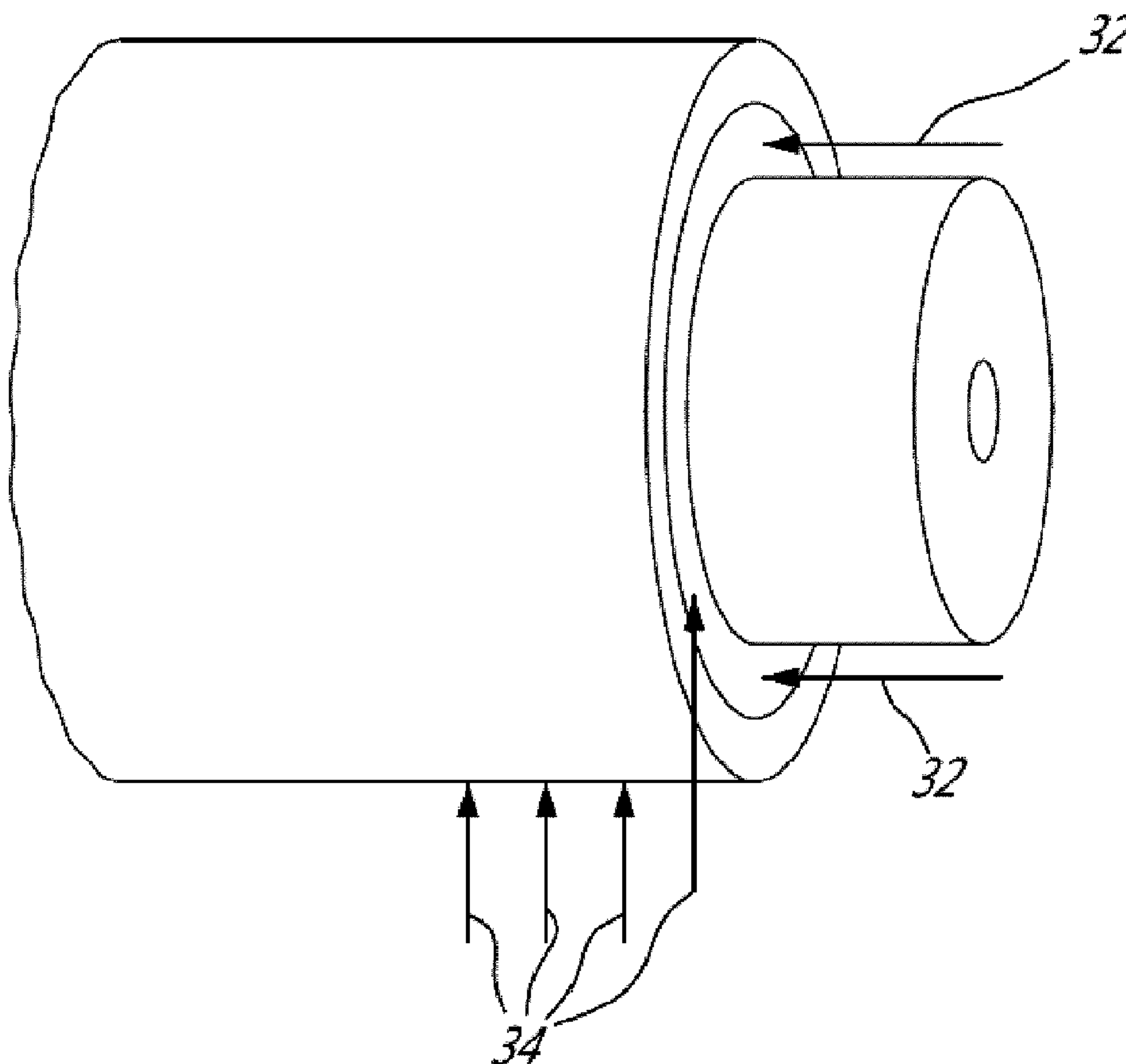

(86) Date de dépôt PCT/PCT Filing Date: 2011/01/14
 (87) Date publication PCT/PCT Publication Date: 2011/07/21
 (45) Date de délivrance/Issue Date: 2013/11/26
 (85) Entrée phase nationale/National Entry: 2012/02/06
 (86) N° demande PCT/PCT Application No.: CA 2011/050015
 (87) N° publication PCT/PCT Publication No.: 2011/085496
 (30) Priorité/Priority: 2010/01/15 (US61/295,353)

(51) Cl.Int./Int.Cl. *G02B 6/44* (2006.01),
G02B 6/036 (2006.01)
 (72) Inventeur/Inventor:
CHATIGNY, STEPHANE, CA
 (73) Propriétaire/Owner:
CORACTIVE HIGH-TECH INC., CA
 (74) Agent: NORTON ROSE FULBRIGHT CANADA
LLP/S.E.N.C.R.L., S.R.L.

(54) Titre : FIBRE OPTIQUE A DOUBLE REVETEMENT COMPORTANT UNE PARTIE DENUDEE SCELLEE
 (54) Title: DOUBLE CLAD OPTICAL FIBER WITH SEALED STRIPPED PORTION



(57) **Abrégé/Abstract:**

A double clad optical fiber having a portion extending along its length along which an outer waveguide cladding and a protective jacket are absent and having faces of the second waveguide cladding at two lengthwisely opposite ends, wherein a water impervious sealant is applied to impede lengthwise diffusion of water through the faces of the second waveguide cladding



(12) INTERNATIONAL APPLICATION PUBLISHED UNDER THE PATENT COOPERATION TREATY (PCT)

(19) World Intellectual Property Organization
International Bureau(43) International Publication Date
21 July 2011 (21.07.2011)(10) International Publication Number
WO 2011/085496 A1

- (51) International Patent Classification: 121, 2700, rue Jean-Perrin, Quebec, Quebec G2C 1S9 (CA).
G02B 6/44 (2006.01) G02B 6/036 (2006.01)
- (21) International Application Number: PCT/CA2011/050015 (72) Inventor; and
(75) Inventor/Applicant (for US only): CHATIGNY, Stephane [CA/CA]; 228, rue des Sittelles, Saint-Redempteur, Quebec G6K 1R8 (CA).
- (22) International Filing Date: 14 January 2011 (14.01.2011) (74) Agent: OGILVY RENAULT, LLP/ S.E.N.C.R.L.,s.r.l.; Suite 1500, Complexe Jules-Dallaire/Tour Ogilvy, Renault, 2828, boulevard Laurier, Quebec, Quebec G1V 0B9 (CA).
- (25) Filing Language: English (81) Designated States (unless otherwise indicated, for every kind of national protection available): AE, AG, AL, AM, AO, AT, AU, AZ, BA, BB, BG, BH, BR, BW, BY, BZ, CA, CH, CL, CN, CO, CR, CU, CZ, DE, DK, DM, DO, DZ, EC, EE, EG, ES, FI, GB, GD, GE, GH, GM, GT,
- (26) Publication Language: English
- (30) Priority Data: 61/295,353 15 January 2010 (15.01.2010) US
- (71) Applicant (for all designated States except US): CORACTIVE HIGH-TECH INC. [CA/CA]; Bureau

[Continued on next page]

(54) Title: DOUBLE CLAD OPTICAL FIBER WITH SEALED STRIPPED PORTION

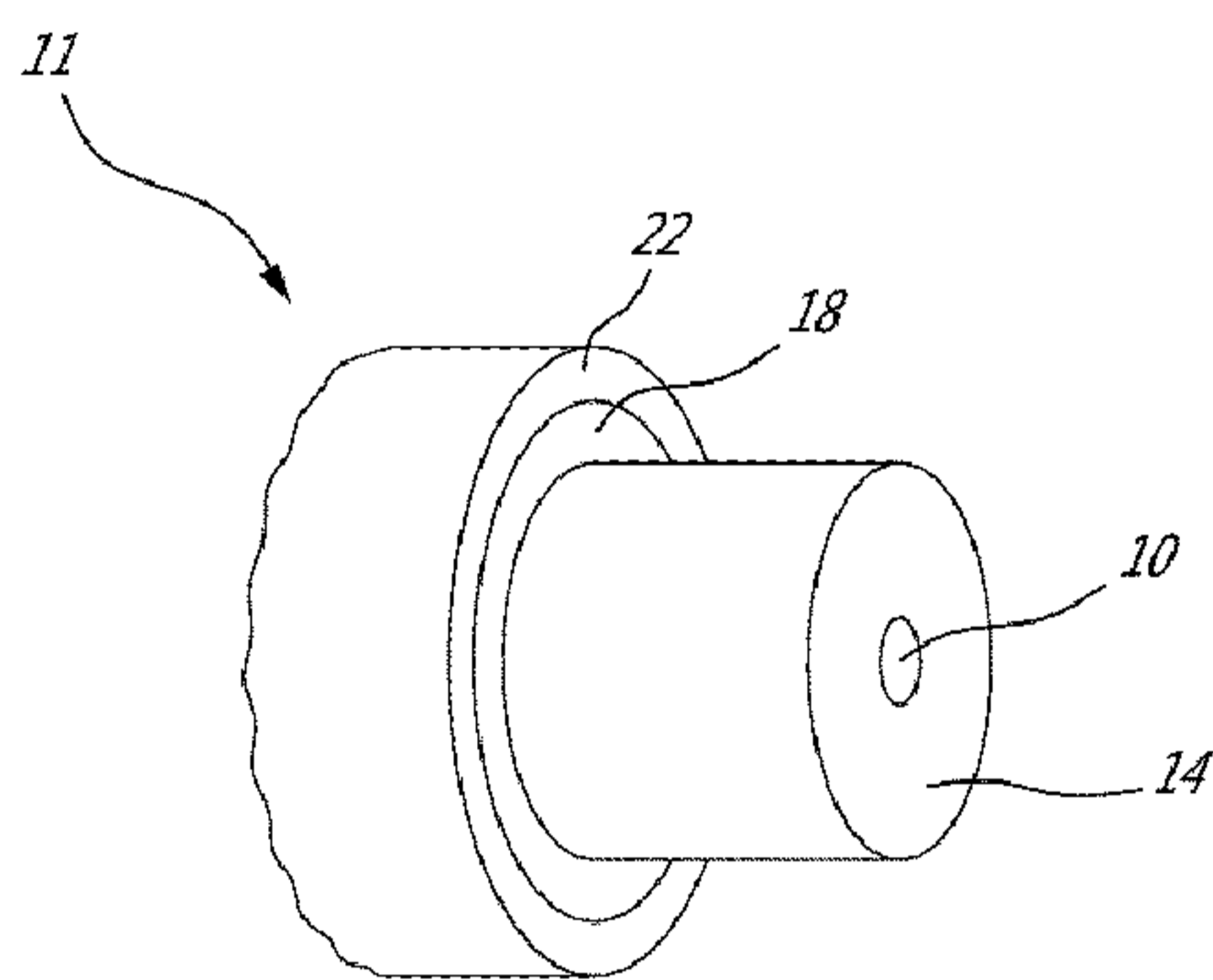

1A (PRIOR ART)

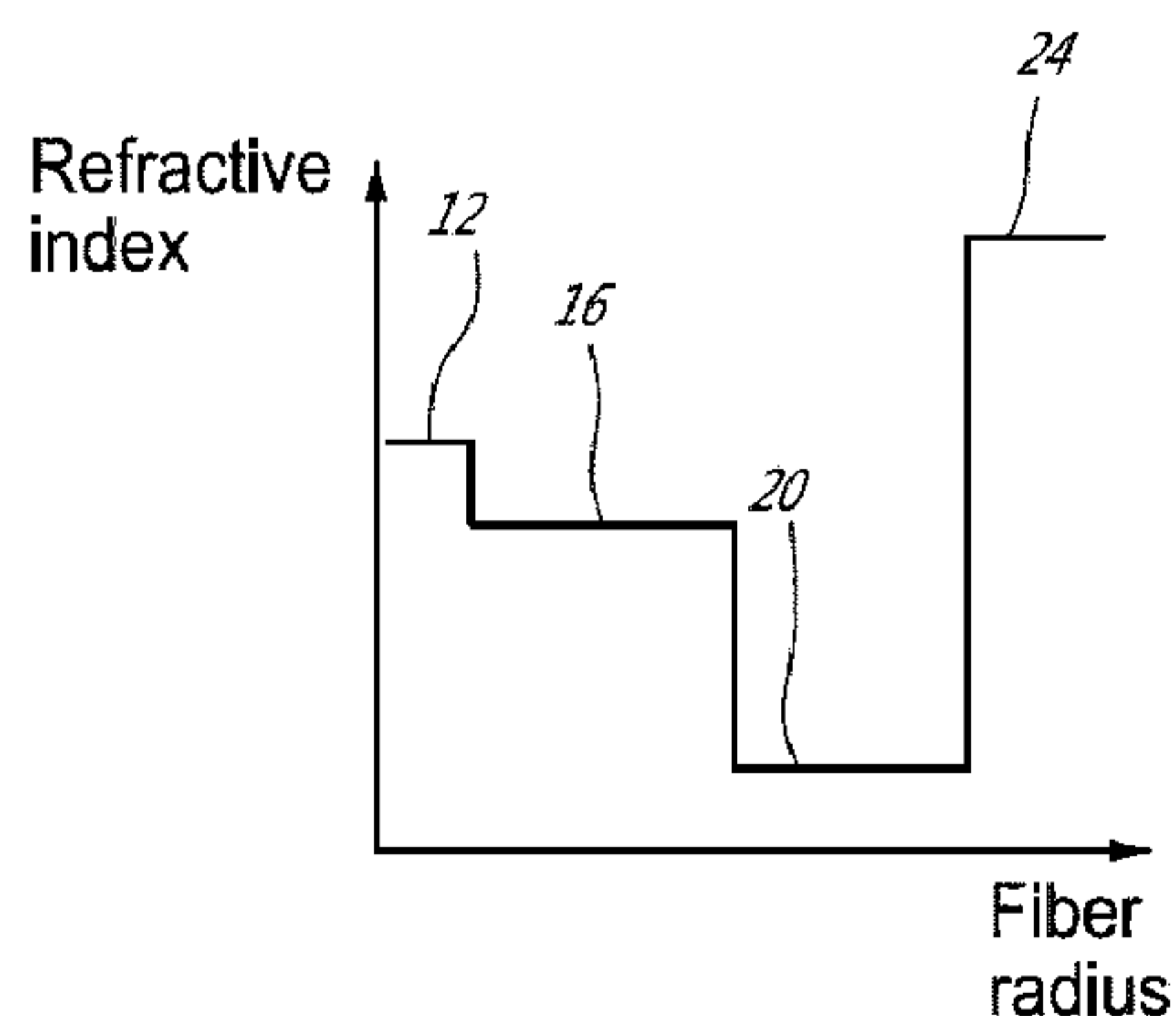

1B (PRIOR ART)

(57) Abstract: A double clad optical fiber having a portion extending along its length along which an outer waveguide cladding and a protective jacket are absent and having faces of the second waveguide cladding at two lengthwisely opposite ends, wherein a water impervious sealant is applied to impede lengthwise diffusion of water through the faces of the second waveguide cladding



WO 2011/085496 A1

WO 2011/085496 A1 

HN, HR, HU, ID, IL, IN, IS, JP, KE, KG, KM, KN, KP, KR, KZ, LA, LC, LK, LR, LS, LT, LU, LY, MA, MD, ME, MG, MK, MN, MW, MX, MY, MZ, NA, NG, NI, NO, NZ, OM, PE, PG, PH, PL, PT, RO, RS, RU, SC, SD, SE, SG, SK, SL, SM, ST, SV, SY, TH, TJ, TM, TN, TR, TT, TZ, UA, UG, US, UZ, VC, VN, ZA, ZM, ZW.

ZM, ZW), Eurasian (AM, AZ, BY, KG, KZ, MD, RU, TJ, TM), European (AL, AT, BE, BG, CH, CY, CZ, DE, DK, EE, ES, FI, FR, GB, GR, HR, HU, IE, IS, IT, LT, LU, LV, MC, MK, MT, NL, NO, PL, PT, RO, RS, SE, SI, SK, SM, TR), OAPI (BF, BJ, CF, CG, CI, CM, GA, GN, GQ, GW, ML, MR, NE, SN, TD, TG).

(84) Designated States (*unless otherwise indicated, for every kind of regional protection available*): ARIPO (BW, GH, GM, KE, LR, LS, MW, MZ, NA, SD, SL, SZ, TZ, UG,

Published:

— *with international search report (Art. 21(3))*

DOUBLE CLAD OPTICAL FIBER WITH SEALED STRIPPED PORTION

CROSS-REFERENCE TO RELATED APPLICATIONS

[0001] This application claims priority of United States provisional patent application no. 61/295,353, entitled "Environmentally Robust Optical Fiber Protection Assembly" filed January 15, 2010 by applicant, the contents of which are hereby incorporated by reference.

BACKGROUND

[0002] Fig. 1 shows an example of a double clad optical fiber 11. The double clad optical fiber 11 generally includes a waveguide core 10 having a core refractive index 12, an inner waveguide cladding 14 around the core having an inner cladding refractive index 16, and an outer waveguide cladding 18 around the inner cladding 14 and having an outer cladding refractive index 20, and a jacket 22 around the outer waveguide cladding 18, having a jacket refractive index 24, typically higher than the outer cladding refractive index 20.

[0003] In the delivery of high power optical signals and in the making of high power fiber lasers and amplifiers, the core 10 can be of doped silica, the inner cladding 14 can have one or more layers of silica glass or doped silica glass, and the outer cladding 18 of non silica material can have an significantly lower refractive index 20 that prevents light from escaping the core 10 and the inner cladding 14. The outer cladding 18 can be made of a low index polymer such as silicone, fluorinated ethylenic-cyclo oxyaliphatic substituted ethylenic copolymer, or another material, but it is common to use fluoroacrylate optical fibers which are characterized by the fact that the material of the second waveguide cladding 18 is a fluoroacrylate, such as product number PC363, PC373, PC375, or PC409 manufactured by SSCP CO. or product DeSolite® DF0007 manufactured by DSM Desotech. In certain cases, the core 10 and the inner cladding 14 are of the same material and therefore can have the same refractive index. To provide a complete example, the protective jacket can be made of a high index acrylate, for instance such as DSM Desotech's product number DS-2015, product number 3471-2-136 or SSCP CO.'s product number UVF-HTS-001. The main function of the jacket is to improve the mechanical performance of the fiber.

SUMMARY

[0004] In some cases, double cladding optical fibers have the outer cladding and the jacket removed along a portion thereof, which can be referred to as a stripped portion 26, such as shown in Fig. 2, which leaves two faces 28, 30 of the outer cladding at corresponding ends of the
5 stripped portion 26. This occurs at splice points and a stripped window points, for instance. In some cases, the portion is left bare such as shown in Fig. 2. In other cases, the portion can be recoated, with the recoating material 31, prior to use as shown in Fig. 3, such as to provide better mechanical resistance for instance. It is common to do the recoating with a same material than the outer cladding.

10 [0005] We have observed that some fluoroacrylate double clad optical fibers having the outer cladding and the jacket removed along one or more portions thereof, with or without recoating presented high amounts of optical attenuation . This problem was investigated in a scientific manner, and subsequent experiments led to the hypothesis that the attenuation could be caused by exposure of the fluoroacrylate of the outer cladding to water. To confirm that hypothesis we
15 have exposed a stripped double clad optical fiber for 429 hours in a 85°C and 85% relative humidity environment. Fig. 4 shows the induced optical loss.

[0006] Analyzing the problem led to understand that water can penetrate into the fluoroacrylate by two main ways, that is radial diffusion 34, in a direction transverse to the length of the fiber, and longitudinal diffusion 32 in a direction parallel to the length of the fiber.
20 This is schematized in Fig. 5. It appeared that the jacket, which is typically of a water-impervious material creates a significant water barrier effect which significantly protects the fluoroacrylate from premature degradation. However, when the optic fiber is left bare, faces of the outer cladding, at opposite ends of the portion, are exposed to water and thus to longitudinal diffusion thereof into the outer cladding layer. Further, it appears that even in cases where the
25 stripped portion is recoated with fluoroacrylate, such as in Fig. 3, the water could first penetrate into the fluoroacrylate recoating 31 by radial diffusion, and then migrate from the fluoroacrylate recoating into the outer cladding by longitudinal diffusion. In this case, the fluoroacrylate recoating 31 and the outer cladding will be degraded by water exposure.

[0007] It was found that the intrusion of water into the outer cladding can be significantly impeded by applying a sealant in a manner to block access of the water to the two faces of the outer cladding at the ends of the stripped portion, which significantly reduces the amount of attenuation when the optic fiber is used in an environment where it is exposed to significant amounts of water.

[0008] Henceforth, in accordance with one aspect, there is provided : a double clad optical fiber having a waveguide core, an inner waveguide cladding around the core having an inner cladding refractive index, and an outer waveguide cladding around the inner cladding having an outer cladding refractive index lower than the inner cladding refractive index, and a jacket around the second waveguide cladding having a jacket refractive index, the optical fiber having a portion extending along its length along which the second waveguide cladding and the jacket are absent, the portion having corresponding faces of the second waveguide cladding at two lengthwisely opposite ends, and having a sealant at said portion, the sealant impeding lengthwise diffusion of environmental water through the faces of the second waveguide cladding.

[0009] In accordance with another aspect, there is provided : a method of protecting a double clad optical fiber having a waveguide core, an inner waveguide cladding around the core, and an outer waveguide cladding around the inner cladding made of a fluoroacrylate, and a jacket around the second waveguide cladding, the optical fiber having a portion extending along its length along which the second waveguide cladding and the protective jacket are absent, the portion having corresponding faces of the second waveguide cladding at two lengthwisely opposite ends, the method comprising : applying a sealant at said portion in a manner to prevent water from affecting the faces of the second waveguide cladding.

[0010] In accordance with another aspect, there is provided : an environmentally robust optic fiber package for an exposed optical fiber, said exposed optical fiber having a core region having a core refractive index, said core region being made of doped silica; an inner cladding region, said inner cladding region being made of one of silica or doped silica, an outer cladding region layer having an outer cladding refractive index, said outer cladding region layer being made of a low refractive index non silica material, and a protective jacket layer; said outer cladding region

layer having an exposed portion for which said protective jacket layer is absent, said exposed portion permitting access to said outer cladding region layer by a contaminant; said package comprising : a cap covering at least said exposed portion by a sealing layer having a sealant refractive index, said sealant refractive index being one of lower than and equal to said outer cladding refractive index, said sealing layer having barrier properties preventing said
5 contaminant to reach said cladding region layer.

[0011] In this specification, the expression water refers to H₂O in liquid and gaseous form.

DESCRIPTION OF THE DRAWINGS

[0012] In the figures,

10 [0013] Fig. 1A (PRIOR ART) shows an example of a double cladding optical fiber;

[0014] Fig. 1B (PRIOR ART) shows a typical refractive index profile of a double cladding optical fiber;

[0015] Fig. 2 shows an example of an double cladding optical fiber having a stripped portion;

15 [0016] Fig. 3 shows an example of a double cladding optical fiber having a stripped portion with a recoat;

[0017] Fig. 4 is a graph showing optical attenuation of a fluoroacrylate coated optical fiber following exposure of the fluoroacrylate to water;

[0018] Fig. 5 schematizes water penetration into the outer cladding;

20 [0019] Fig. 6 shows a first example of an optical fiber with a sealant, where the sealant is applied onto a recoat;

[0020] Fig. 7 shows a second example of an optical fiber with a sealant, where the sealant is applied directly onto the bare stripped portion;

[0021] Fig. 8 shows a third example of an applied sealant, where the sealant is applied directly on exposed faces of the outer cladding; and

[0022] Fig. 9 is a graph showing results of tests done with the stripped portion left bare, and with a sealant applied.

5 [0023] It will be noted that throughout the appended drawings, like features are identified by like reference numerals.

DETAILED DESCRIPTION

[0024] A stripped portion such as shown in Fig. 2 occurs for instance at splice points. To splice two fibers, the fibers are first stripped, which can be done mechanically, thermally or
10 chemically. A mechanical stripping can be done with, for example, a microstrip fiber stripper to remove the protective jacket 22 and the outer cladding 18. Thermal stripping is similar to mechanical stripping with the exception that the stripping blades are heated or that the coating is heated in an oven. Chemical stripping is done by dipping the fiber into a chemical agent such as methylene chloride or acetone. Other methods of stripping such as laser and hot air could be
15 employed as well. After the stripping is completed, the two portions of exposed glass are then cleaned, with isopropanol for example, to remove contaminant such as dust or coating/cladding residue. The glass ends of the two fibers are cleaved using a fiber cleaver, such as the York FK11. Afterwards, the fibers are spliced together using a standard fusion splicer such as the Fujikura FSM-45F. Other applications have a stripped portion even in cases where there is no
20 splicing, such as window strip applications. In window strip applications, the fibers do not need to be cleaved and spliced; a window is simply stripped over a portion of the fiber. In applications such as power combiners, for instance, the stripped portion is typically left bare.

[0025] However, in other applications, it can be preferred to recoat the stripped portion such as to achieve better mechanical resistance. The exposed glass surface can be recoated with a UV
25 curable fluoroacrylate using a fiber recoater such as the Vytran PTR-200, for instance.

[0026] As detailed above, the optical performance of the fluoroacrylate layer can be affected by exposition to water. This can be caused by phenomena such as delamination or crystallization. In unstripped portions of the fiber, the protective jacket can be considered to play an important environmental role in providing a barrier that slows down the penetration of water and reduces the degradation of the fluoroacrylate layer.

[0027] The degradation is depicted in Fig. 4, which shows the optical attenuation induced in a typical fluoroacrylate optical fiber when exposed to water. The results are shown in the typical pumping wavelength band of Yb, YbEr and Er fiber lasers. Two major degradation components are visible in Fig. 4, first there is a peak at 955nm, likely stemming from the molecular absorption of OH⁻ that diffuses through the fluoroacrylate layer, and there is also a scattering component that likely results from the delamination or the crystallization of the fluoroacrylate layer.

[0028] Fig 5 shows the two main water penetration mechanisms in the fluoroacrylate layer. The first one is the radial diffusion of water through the protective jacket which allows water to reach the outer cladding. This mechanism can be quite slow, perhaps negligible, if the protective jacket is in good condition. The second mechanism is the longitudinal penetration by direct exposition of the outer cladding surface to water. This latter type of penetration mechanism can occur at a splice point, a stripped window point, at a recoated portion recoated by a fluoroacrylate or at a position where protective jacket is removed, to name a few examples. Water can then attack outer cladding directly via a chemical reaction but can also penetrate by capillarity and cause delamination of the outer cladding.

[0029] Fig. 6 shows a first exemplary embodiment. In this case, the exposed glass is subsequently recoated with an UV curable fluoroacrylate recoat layer. This can be done using a fiber recoater such as the Vytran PTR-200. At the location where the recoat layer is in direct contact with water, a sealant cap is added in order to significantly impede the penetration of water into the outer cladding and the recoat layer. Also, the sealant cap is heat resistant, in the sense that its optical and mechanical parameters do not significantly degrade for temperatures up to 85°C. The sealant cap is also chemically stable when exposed to water in a temperature

ranging from -40°C to 85°C . The following materials are examples which can be used for the sealant cap : an acrylate such as as DSM DS-2015, 3471-2-136 or SSCP CO. UVF-HTS-001, silicone (such as Nusil Lightspan LS-3), fluorinated ethylenic-cyclo oxyaliphatic substituted ethylenic copolymer (such as Teflon AF available from Dupont), an optical epoxy with a low refractive index (such as ÅngströmBond EX1128), etc. This sealant material will be applied once the recoat layer is cured, the recoat layer is subsequently placed in a mold that can be filled with the sealant material. In some cases, placing the sealant material in an oven or using with an infrared (IR) source can accelerate curing. The ICure IR source from IRPhotonics is an example. Alternately, some materials can be cured with a UV light source, such as the Dymax 5000-EC curing system for instance.

[0030] Fig. 7 shows another exemplary embodiment where the portion is not recoated with a fluoroacrylate material, but rather with a more stable sealant cap 46 of a material such as a low index optical epoxy, silicone or fluorinated ethylenic-cyclo oxyaliphatic substituted ethylenic copolymer, for instance. This can be done in a manner similar to that which is described above. In this case, the refractive index of the sealant cap should be equal to or inferior to the refractive index of the outer cladding 48 and should be transparent to the light propagating in the inner cladding 14 and the core 10.

[0031] Fig. 8 shows still another exemplary embodiment where the stripped region 50 is left uncoated. In such a case the outer cladding can be sealed using a sealant cap 54 made of a sealant material such as a low index epoxy with proper environmental properties, while ensuring that the splice joint or window is left exposed. A drop of the sealant material can be applied to the exposed outer cladding layer with a syringe. In this case, the refractive index of the sealant material should be equal to or inferior to the refractive index of the outer cladding 52 and should be transparent to the light propagating in the inner cladding 14 and the core 10.

[0032] In all embodiments, the sealed fiber can then be placed in an enclosure for mechanical, thermal and environmental protection.

[0033] Fig. 9 shows test results taken with a 125 micron standard fluoroacrylate fiber which was stripped on 5 cm. A first such fiber was left completely unrecoated. A second such fiber was

recoated with fluoroacrylate, and a sealant cap layer of the same type of acrylate than the jacket of the fiber was applied. Both fibers were placed in an experimental room at 85% relative humidity and 85°C for 300 hours. The results show an attenuation of the order of .4 dB for the unrecoated fiber, whereas the sealed fiber shows no significant attenuation.

- 5 [0034] The embodiments described above are intended to be exemplary only. The scope of the invention is therefore intended to be limited solely by the appended claims.

I/WE CLAIM:

1. A double clad optical fiber having a waveguide core, an inner waveguide cladding around the core having an inner cladding refractive index, and an outer waveguide cladding around the inner cladding having an outer cladding refractive index lower than the inner cladding refractive index, and a jacket around the second waveguide cladding having a jacket refractive index, the optical fiber having a portion extending along its length along which the second waveguide cladding and the jacket are absent, the portion having corresponding faces of the second waveguide cladding at two lengthwisely opposite ends, and having a sealant at said portion, the sealant impeding lengthwise diffusion of environmental water through the faces of the second waveguide cladding.
2. The double clad optical fiber of claim 1 wherein the second waveguide cladding is a fluoroacrylate cladding.
3. The double clad optical fiber of claim 1 or 2 wherein the sealant is applied directly onto and entirely covers the two faces of the second waveguide cladding.
4. The double clad optical fiber of claim 3 wherein the sealant extends along the entire length of the portion, entirely covers the first waveguide cladding, and has a refractive index at least as low as the outer cladding refractive index.
5. The double clad optical fiber of claim 2 wherein a fluoroacrylate recoating is applied directly onto and entirely covers each of the two faces of the second waveguide cladding and the first waveguide cladding along the entire length of the portion, and the sealant is applied directly onto and entirely covers the fluoroacrylate recoating.
6. The double clad optical fiber of claim 5, wherein the sealant is of the same material than the jacket.
7. The double clad optical fiber of any one of claims 1 to 5 wherein the sealant is one of a PTFE, a silicone, an acrylate, and an epoxy.

8. A method of protecting a double clad optical fiber having a waveguide core, an inner waveguide cladding around the core, and an outer waveguide cladding around the inner cladding made of a fluoroacrylate, and a jacket around the second waveguide cladding, the optical fiber having a portion extending along its length along which the second waveguide cladding and the protective jacket are absent, the portion having corresponding faces of the second waveguide cladding at two lengthwisely opposite ends, the method comprising :

applying a sealant at said portion in a manner to prevent water from affecting the faces of the second waveguide cladding.

9. The method of claim 8 wherein said step of applying includes applying the sealant directly onto and in a manner to entirely cover the two faces of the second waveguide cladding.

10. The method of claim 9 wherein the step of applying further includes applying the sealant directly onto and in a manner to entirely cover the inner cladding along the entire length of the portion.

11. The method of claim 8 further comprising recoating with a recoat fluoroacrylate material directly onto and in a manner to entirely cover each of the two faces of the second waveguide cladding and the inner cladding along the entire length of the portion, wherein said step of applying includes applying the sealant directly onto and in a manner to entirely cover the recoat fluoroacrylate material.

12. An environmentally robust optic fiber package for an exposed optical fiber, said exposed optical fiber having a core region having a core refractive index, said core region being made of doped silica; an inner cladding region, said inner cladding region being made of one of silica or doped silica, an outer cladding region layer having an outer cladding refractive index, said outer cladding region layer being made of a low refractive index non silica material, and a protective jacket layer;

said outer cladding region layer having an exposed portion for which said protective jacket layer is absent, said exposed portion permitting access to said outer cladding region layer by a contaminant;

said package comprising :

a cap covering at least said exposed portion by a sealing layer having a sealant refractive index, said sealant refractive index being one of lower than and equal to said outer cladding refractive index, said sealing layer having barrier properties preventing said contaminant to reach said cladding region layer.

13. The package of claim 12, wherein said contaminant is water.

14. The package of claim 12 or 13, wherein said exposed portion is an end face of said outer cladding region layer at an edge of a stripped window portion of said optical fiber, whereby a stripped length of said outer cladding region layer and said protective jacket layer are removed to expose said inner cladding region.

15. The package of claim 12 or 13, wherein said exposed portion is a surface portion of said outer cladding region layer where said protective jacket layer is removed.

16. The package of any one of claim 12 to 15, wherein said sealant is a low index epoxy with water barrier properties.

17. The package of any one of claim 12 to 15, wherein said sealant is made of silicone.

18. The package any one of claim 12 to 15, wherein said sealant is made of fluorinated ethylenic-cyclo oxyaliphatic substituted ethylenic copolymer.

19. The package of any one of claim 12 to 18, wherein said cap is adapted to be provided over a cladding region layer recoat covering at least said exposed portion.

20. The package of any one of claim 12 to 19, wherein said core region and said inner cladding region are provided in a single doped silica region.

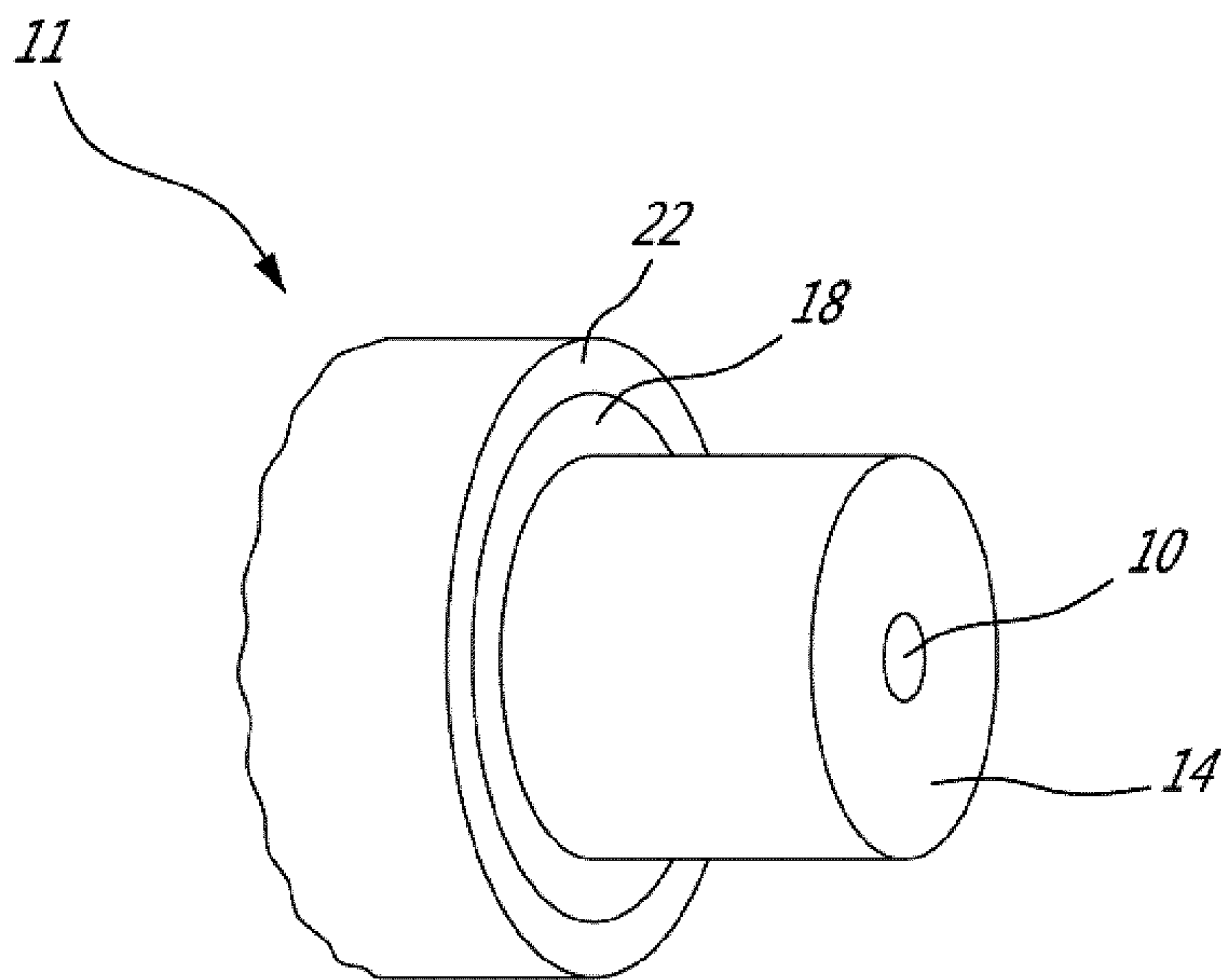

FIG. 1A (PRIOR ART)

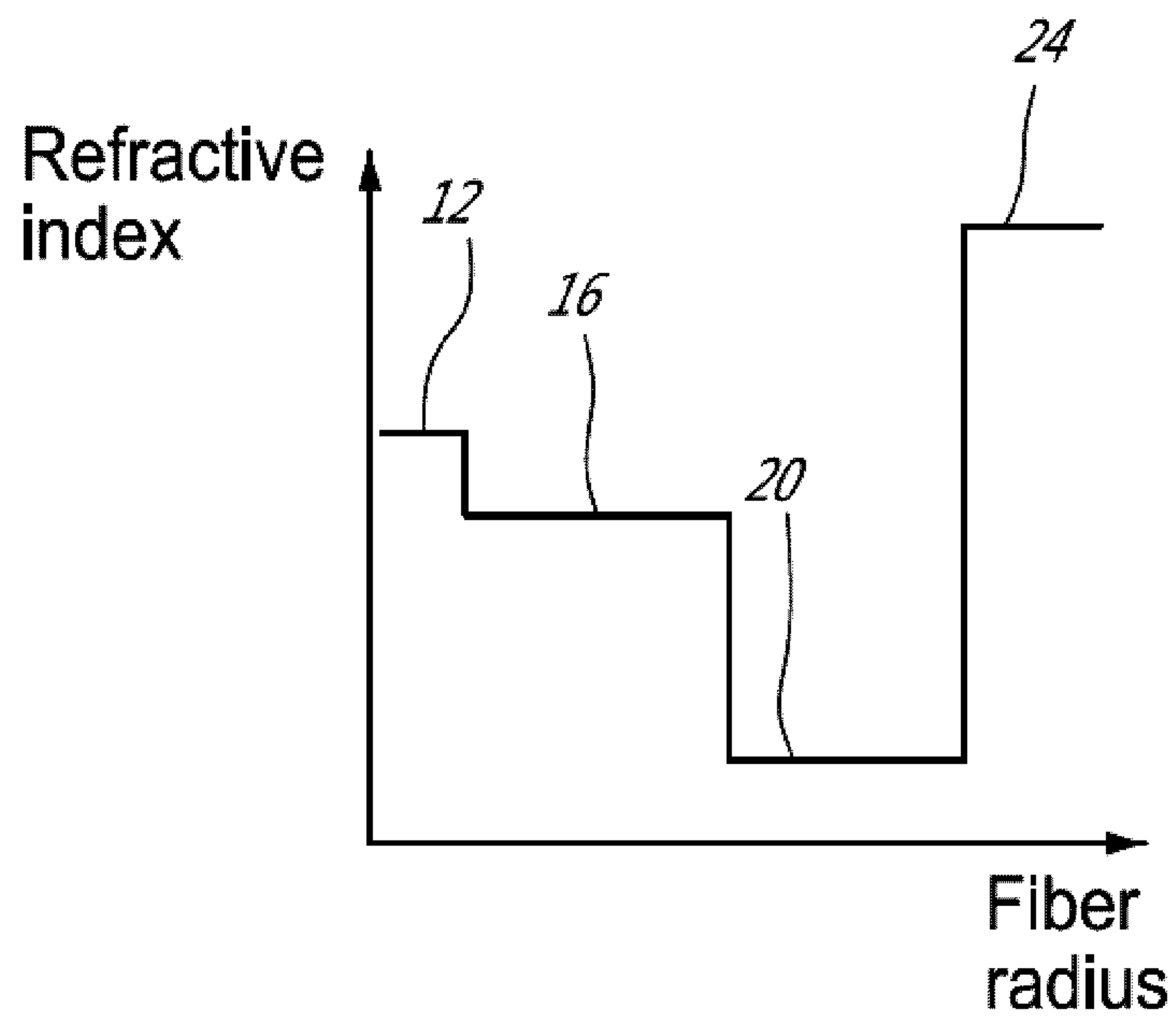
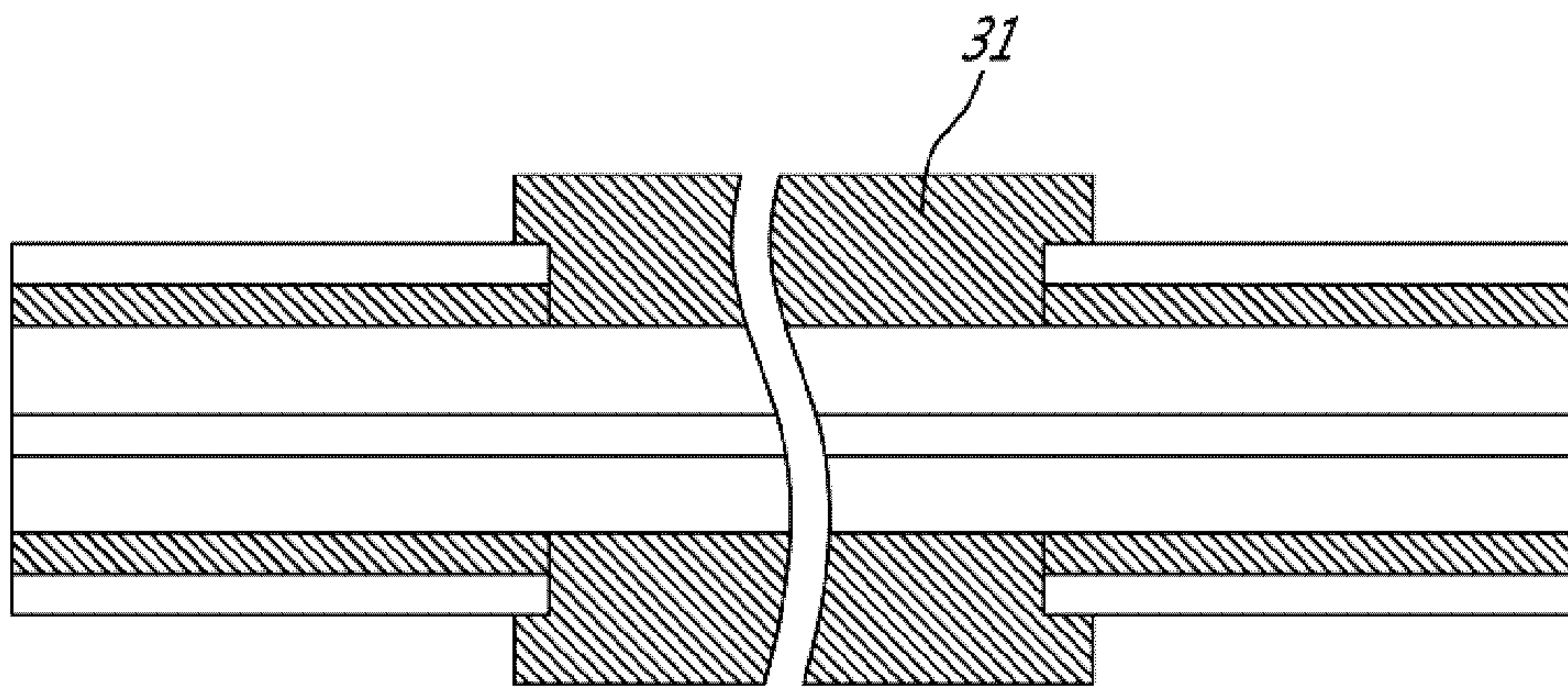
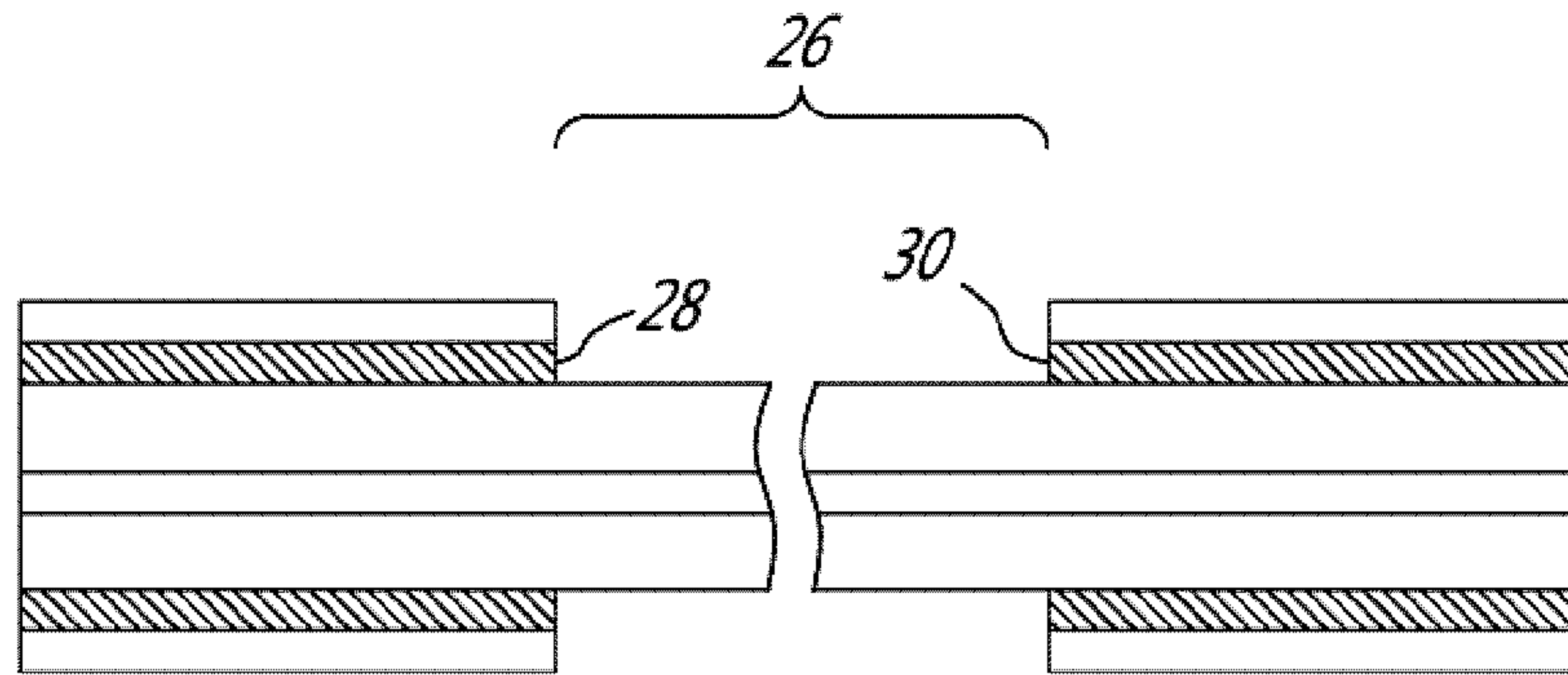

FIG. 1B (PRIOR ART)

2 / 7



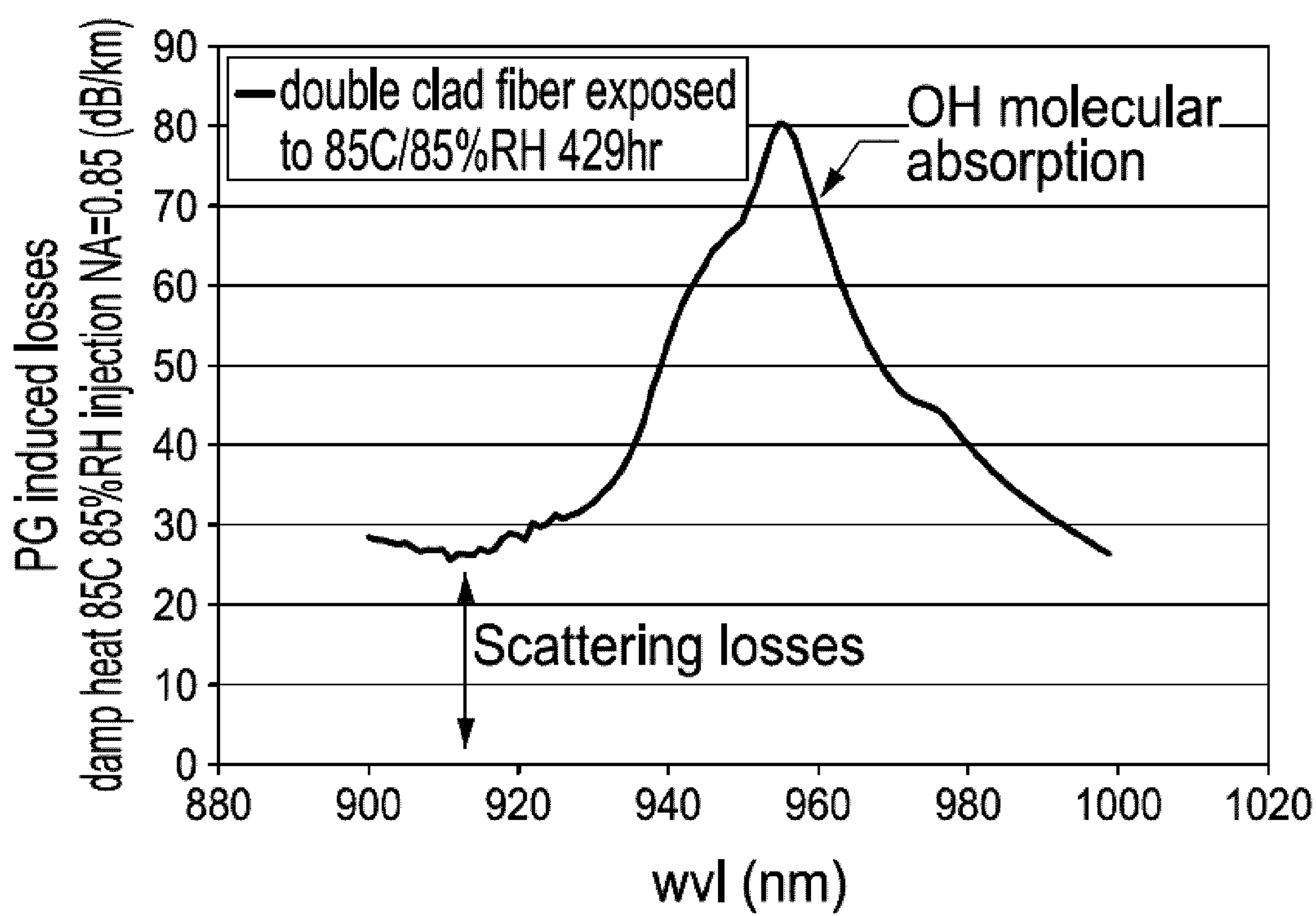

FIG. 4

4 / 7

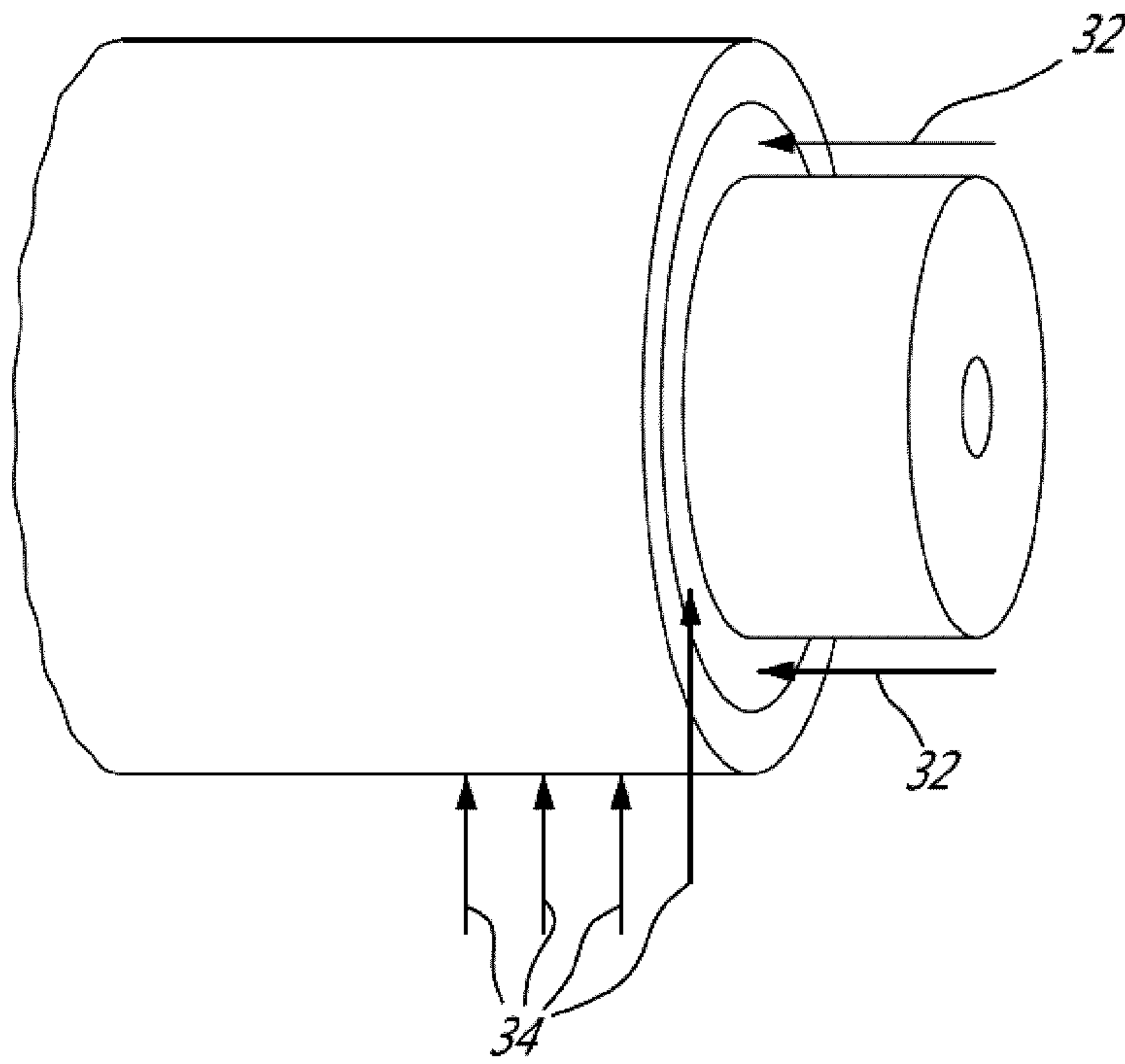

FIG. 5

5 / 7

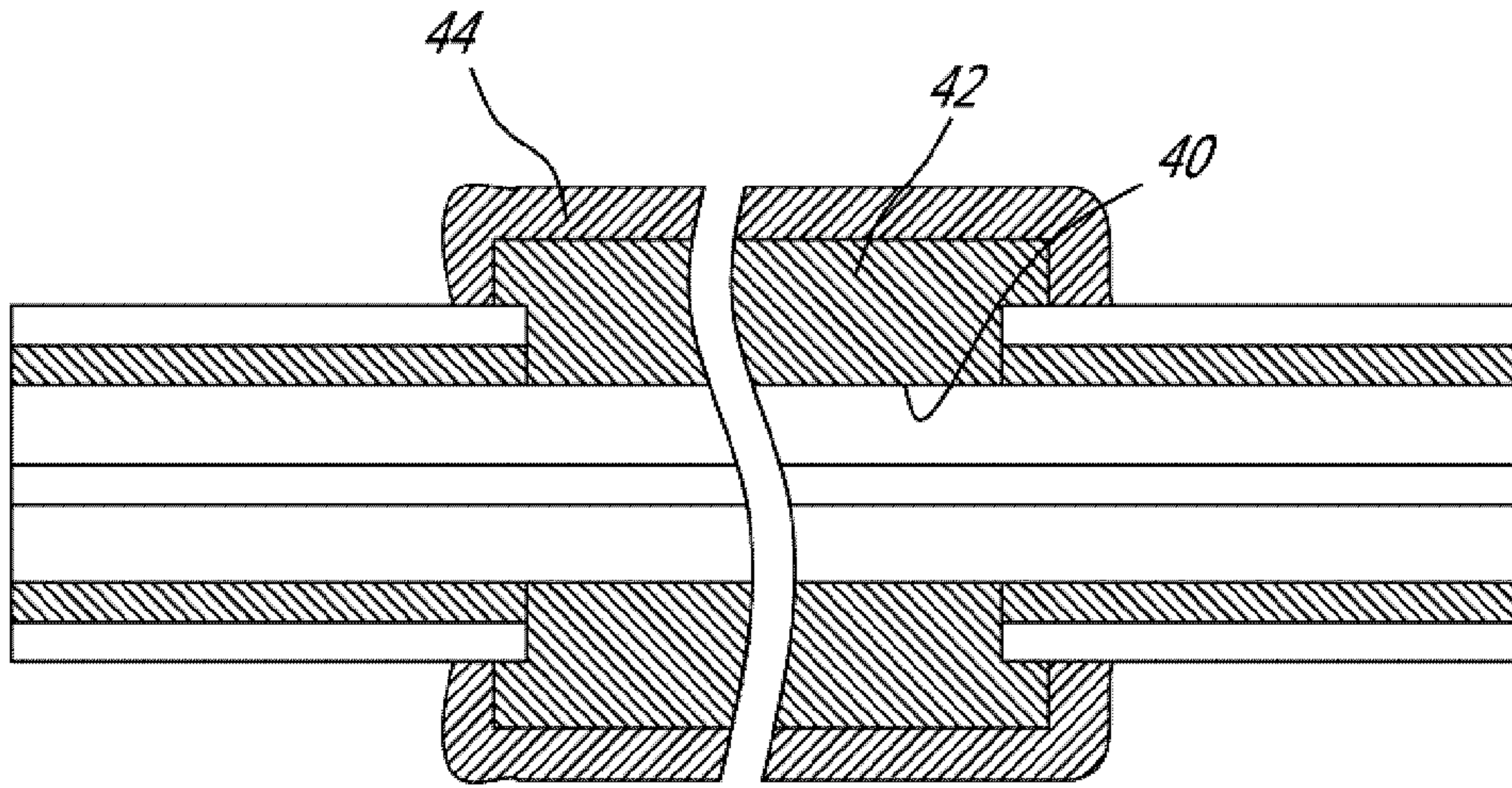

FIG. 6

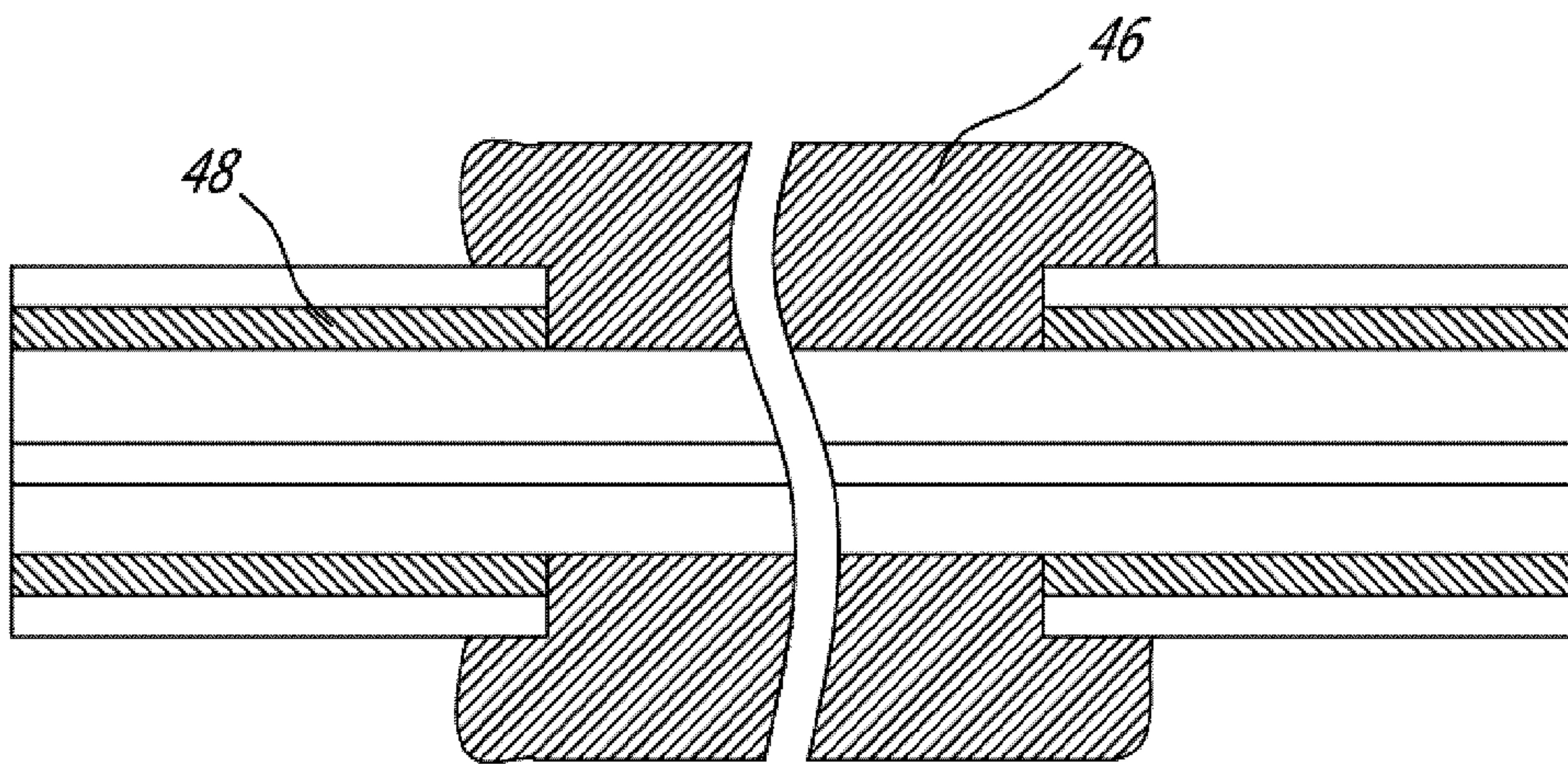
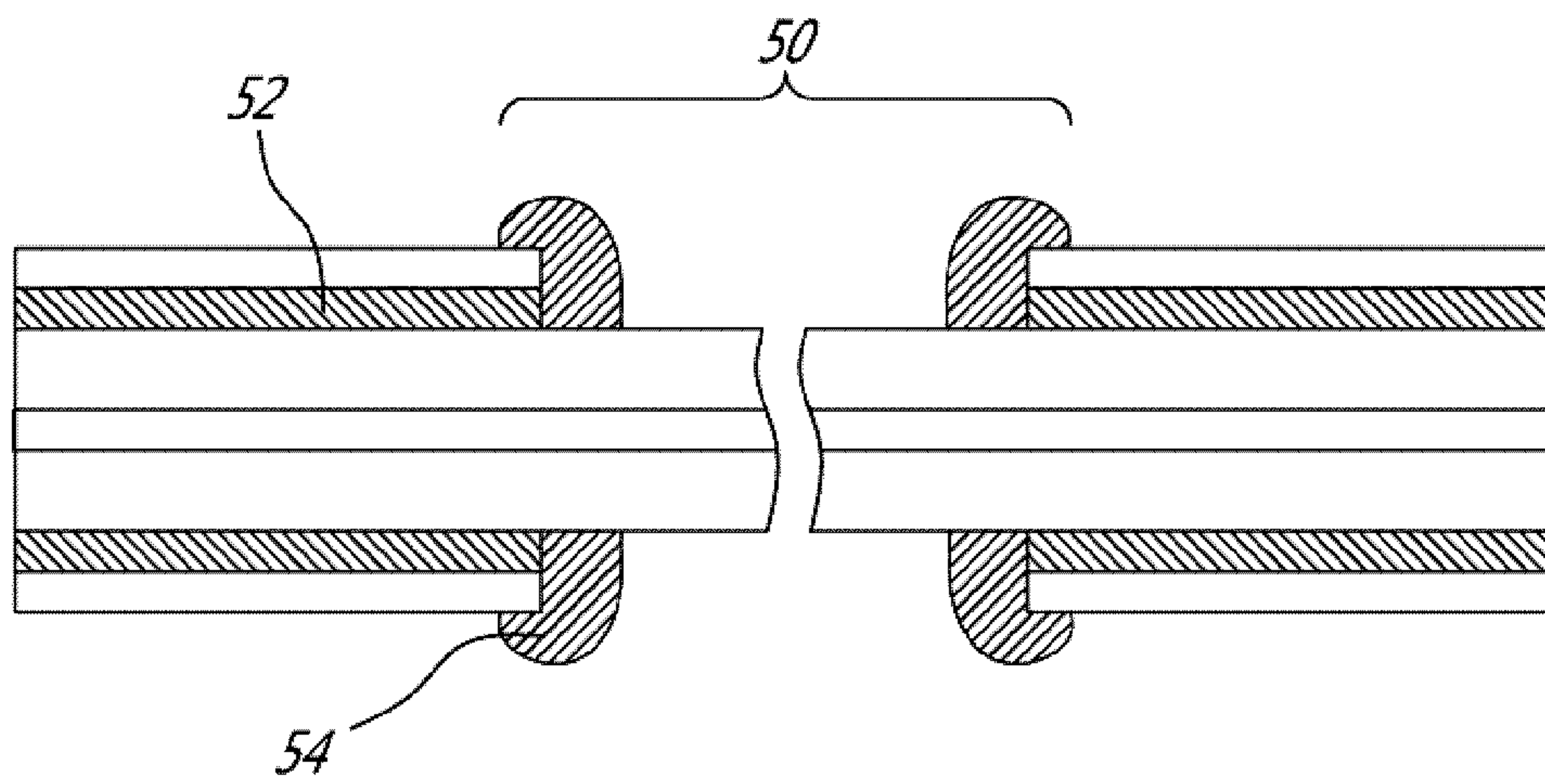

FIG. 7

6 / 7



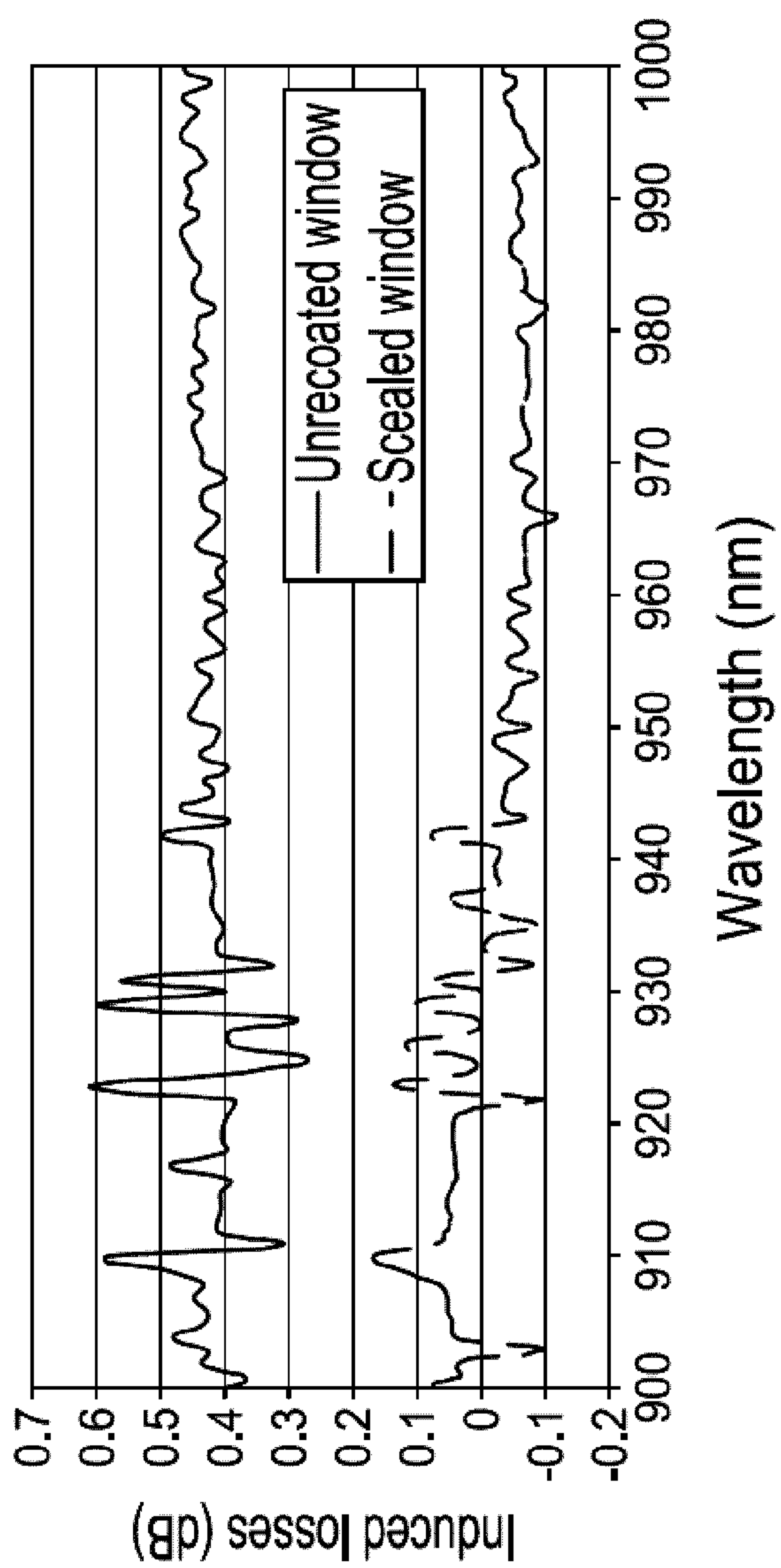

FIG. 9

