

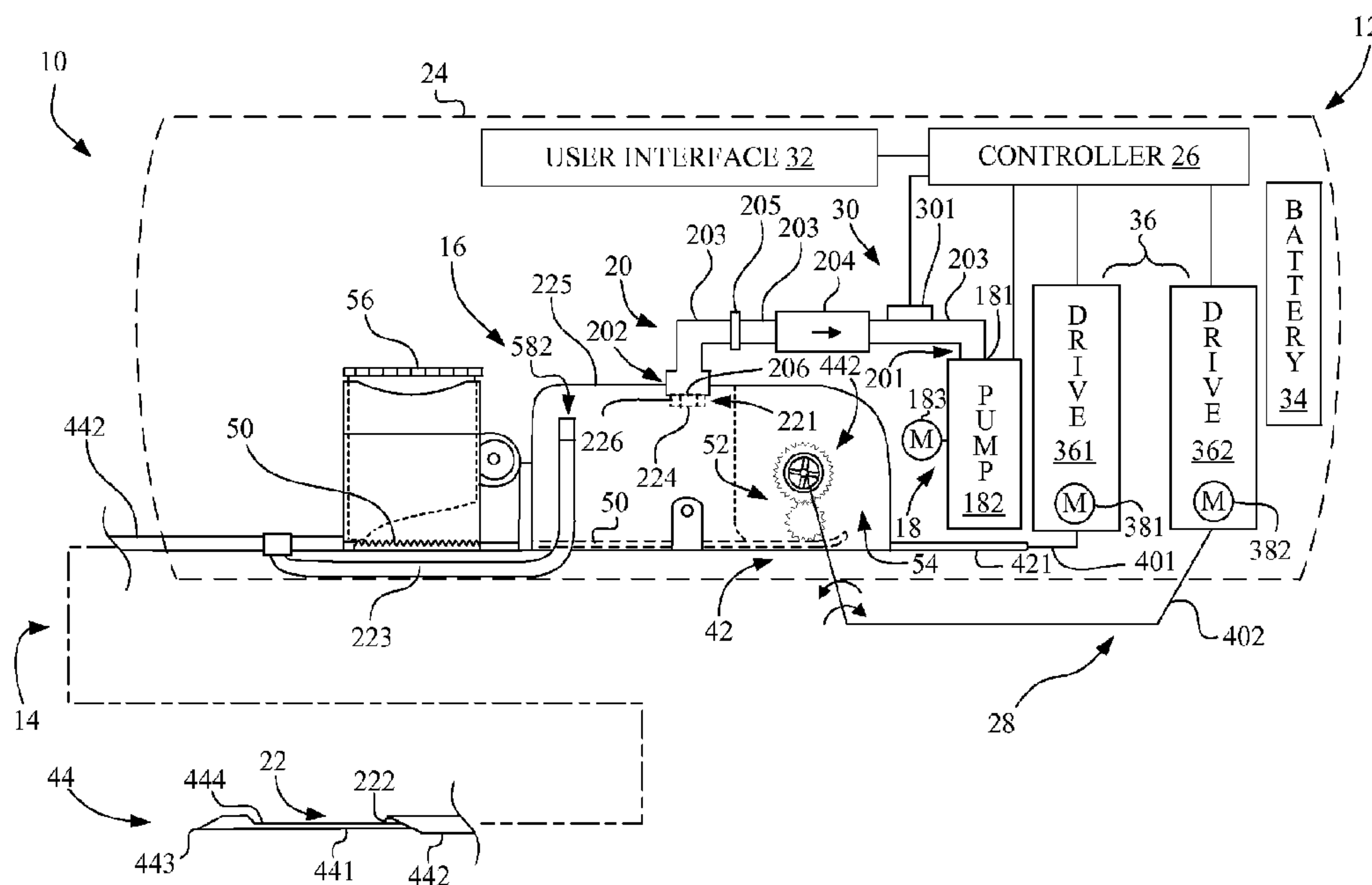

(86) Date de dépôt PCT/PCT Filing Date: 2009/04/15
 (87) Date publication PCT/PCT Publication Date: 2010/10/21
 (45) Date de délivrance/Issue Date: 2017/06/06
 (85) Entrée phase nationale/National Entry: 2011/08/15
 (86) N° demande PCT/PCT Application No.: US 2009/040663
 (87) N° publication PCT/PCT Publication No.: 2010/120294

(51) Cl.Int./Int.Cl. *A61B 10/02* (2006.01),
G01N 1/14 (2006.01)
 (72) Inventeur/Inventor:
VIDEBAEK, KARSTEN, DK
 (73) Propriétaire/Owner:
C.R. BARD, INC., US
 (74) Agent: SMART & BIGGAR

(54) Titre : APPAREIL DE BIOPSIE AYANT UNE GESTION DE FLUIDE INTEGREE
 (54) Title: BIOPSY APPARATUS HAVING INTEGRATED FLUID MANAGEMENT



(57) **Abrégé/Abstract:**

A biopsy apparatus includes a driver assembly to be grasped by a user and a disposable biopsy probe assembly for releasable attachment to the driver assembly. The driver assembly includes a first vacuum path having a first one-way valve configured and arranged to permit a negative pressure fluid flow toward a vacuum source and to prevent a positive pressure fluid flow away from the vacuum source. The disposable biopsy probe assembly includes a second vacuum path having a second one-way valve configured and arranged to permit the negative pressure fluid flow from a sample basket and to redundantly prevent the positive pressure fluid flow toward the sample basket. In some embodiments, a fluid management tank may be fluidically interposed in the second vacuum path to prevent a flow of residual biopsy biological material from the sample basket to the vacuum source.

(12) INTERNATIONAL APPLICATION PUBLISHED UNDER THE PATENT COOPERATION TREATY (PCT)

(19) World Intellectual Property Organization
International Bureau(43) International Publication Date
21 October 2010 (21.10.2010)(10) International Publication Number
WO 2010/120294 A1

(51) International Patent Classification:

A61B 10/02 (2006.01) G01N 1/14 (2006.01)

(21) International Application Number:

PCT/US2009/040663

(22) International Filing Date:

15 April 2009 (15.04.2009)

(25) Filing Language:

English

(26) Publication Language:

English

(71) Applicant (for all designated States except US): **C.R. BARD, INC.** [US/US]; 730 Central Avenue, Murray Hill, NJ 07974 (US).

(72) Inventor; and

(75) Inventor/Applicant (for US only): **VIDEBAEK, Karsten** [DK/DK]; Agnetevej 35, Jyllinge (DK).(74) Agents: **DASPIT, Jaqueline, M.** et al.; Division Staff Attorney, IP, C.R. Bard, Inc., Bard Peripheral Vascular, Inc., 1415 W. 3rd St., P.O. Box 1740, Tempe, AZ 85280-1740 (US).

(81) Designated States (unless otherwise indicated, for every kind of national protection available): AE, AG, AL, AM, AO, AT, AU, AZ, BA, BB, BG, BH, BR, BW, BY, BZ, CA, CH, CN, CO, CR, CU, CZ, DE, DK, DM, DO, DZ,

EC, EE, EG, ES, FI, GB, GD, GE, GH, GM, GT, HN, HR, HU, ID, IL, IN, IS, JP, KE, KG, KM, KN, KP, KR, KZ, LA, LC, LK, LR, LS, LT, LU, LY, MA, MD, ME, MG, MK, MN, MW, MX, MY, MZ, NA, NG, NI, NO, NZ, OM, PG, PH, PL, PT, RO, RS, RU, SC, SD, SE, SG, SK, SL, SM, ST, SV, SY, TJ, TM, TN, TR, TT, TZ, UA, UG, US, UZ, VC, VN, ZA, ZM, ZW.

(84) Designated States (unless otherwise indicated, for every kind of regional protection available): ARIPO (BW, GH, GM, KE, LS, MW, MZ, NA, SD, SL, SZ, TZ, UG, ZM, ZW), Eurasian (AM, AZ, BY, KG, KZ, MD, RU, TJ, TM), European (AT, BE, BG, CH, CY, CZ, DE, DK, EE, ES, FI, FR, GB, GR, HR, HU, IE, IS, IT, LT, LU, LV, MC, MK, MT, NL, NO, PL, PT, RO, SE, SI, SK, TR), OAPI (BF, BJ, CF, CG, CI, CM, GA, GN, GQ, GW, ML, MR, NE, SN, TD, TG).

Declarations under Rule 4.17:

- as to applicant's entitlement to apply for and be granted a patent (Rule 4.17(ii))
- of inventorship (Rule 4.17(iv))

Published:

- with international search report (Art. 21(3))

(54) Title: BIOPSY APPARATUS HAVING INTEGRATED FLUID MANAGEMENT

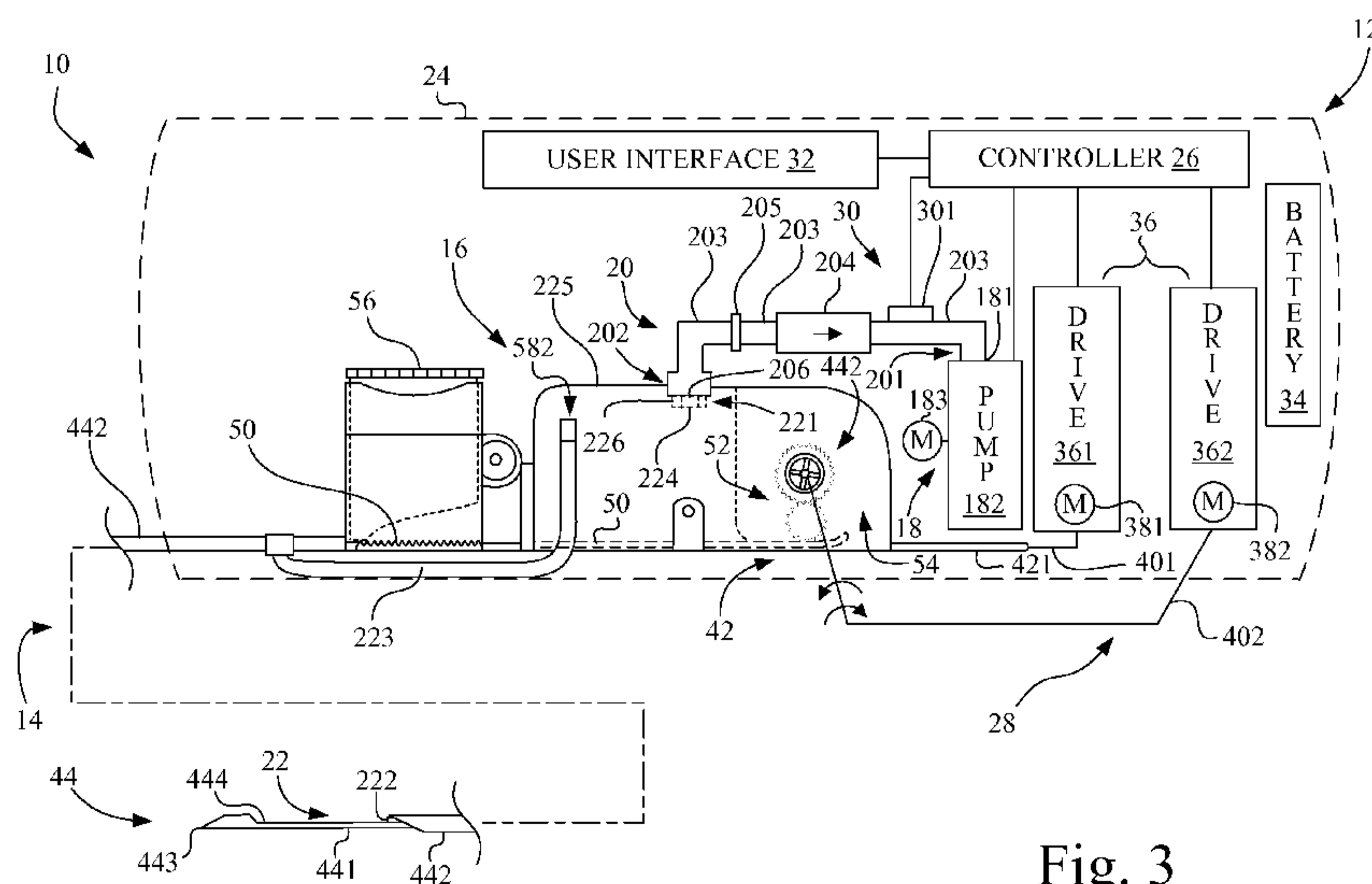

Fig. 3

(57) Abstract: A biopsy apparatus includes a driver assembly to be grasped by a user and a disposable biopsy probe assembly for releasable attachment to the driver assembly. The driver assembly includes a first vacuum path having a first one-way valve configured and arranged to permit a negative pressure fluid flow toward a vacuum source and to prevent a positive pressure fluid flow away from the vacuum source. The disposable biopsy probe assembly includes a second vacuum path having a second one-way valve configured and arranged to permit the negative pressure fluid flow from a sample basket and to redundantly prevent the positive pressure fluid flow toward the sample basket. In some embodiments, a fluid management tank may be fluidically interposed in the second vacuum path to prevent a flow of residual biopsy biological material from the sample basket to the vacuum source.

WO 2010/120294 A1

BIOPSY APPARATUS HAVING INTEGRATED FLUID MANAGEMENT**BACKGROUND OF THE INVENTION****1. Field of the Invention**

[0002] The present invention relates to a biopsy apparatus, and, more particularly, to a biopsy apparatus having integrated fluid management.

2. Description of the Related Art

[0003] A biopsy may be performed on a patient to help in determining whether the cells in a biopsied region are cancerous. One biopsy technique used to evaluate breast tissue, for example, involves inserting a biopsy probe into the breast tissue region of interest to capture one or more tissue samples from the region. Such a biopsy technique often utilizes a vacuum to pull the tissue to be sampled into a sample notch of the biopsy probe, after which the tissue is severed and collected. One type of vacuum assisted biopsy apparatus includes a hand-held driver assembly having a vacuum source, and a disposable biopsy probe assembly configured for releasable attachment to the driver assembly. However, in the presence of the desired negative pressure generated by the vacuum source, residual biopsy biological material, e.g., blood and particulate matter, may be drawn into the vacuum path from the patient along with the tissue sample, and thus potentially contaminating the hand-held driver assembly. Also, in the event of an undesirable positive pressure arising in the vacuum path, the potential exists for a reverse flow of fluid in a direction from the hand-held driver assembly to the patient via the disposable biopsy probe assembly.

SUMMARY OF THE INVENTION

[0004] The present invention provides a fully integrated hand-held biopsy apparatus having fluid management to reduce the potential for a transfer of contaminants during a biopsy procedure.

[0005] As used herein, the terms “first” and “second” preceding an element name, e.g., first vacuum path, second vacuum path, etc., are for identification purposes to distinguish between different elements having similar characteristic, and are not intended to necessarily imply order, unless otherwise specified, nor are the terms “first” and “second” intended to preclude the inclusion of additional similar elements.

[0006] The invention in one form is directed to a biopsy apparatus. The biopsy apparatus includes a driver assembly configured to be grasped by a user and a disposable biopsy probe assembly configured for releasable attachment to the driver assembly. The driver assembly includes an electromechanical power source, a vacuum source, and a first vacuum path permanently associated with the vacuum source. The first vacuum path has a proximal end and a distal end, the proximal end being fixedly coupled to the vacuum source in fluid communication therewith. The first vacuum path has a first one-way valve configured and arranged to permit a negative pressure fluid flow toward the vacuum source and to prevent a positive pressure fluid flow away from the vacuum source toward the distal end. The disposable biopsy probe assembly includes a transmission device, a biopsy probe, and a second vacuum path. The transmission device is configured for driving engagement with the electromechanical power source. The biopsy probe is drivably coupled to the transmission device, and the biopsy probe has a sample basket for receiving a biopsy tissue sample. The second vacuum path has a first end and a second end, the first end

being configured for removable attachment to the distal end of the first vacuum path and the second end being coupled in fluid communication with the sample basket.

The second vacuum path has a second one-way valve configured and arranged to permit the negative pressure fluid flow from the sample basket and to redundantly prevent the positive pressure fluid flow from the first end of the second vacuum path toward the sample basket.

[0007] In some embodiments, for example, the disposable biopsy probe assembly may further include a fluid management tank fluidically interposed in the second vacuum path between the first end and the second end. The fluid management tank includes a body and a filter arrangement contained within the body. The filter arrangement is configured to prevent a flow of residual biopsy biological material from the sample basket to the vacuum source.

[0008] The invention in another form is directed to a fluid management system for use in a biopsy apparatus that utilizes a biopsy probe having a sample basket configured to receive a biopsy tissue sample. The fluid management system includes a vacuum source, a non-disposable vacuum path, and a disposable vacuum path. The non-disposable vacuum path has a proximal end and a distal end, the proximal end being fixedly coupled to the vacuum source in fluid communication therewith. The non-disposable vacuum path includes a first one-way valve configured and arranged to permit a negative pressure fluid flow toward the vacuum source and to prevent a positive pressure fluid flow away from the vacuum source toward the distal end of the non-disposable vacuum path. The disposable vacuum path is temporarily coupled in fluid communication with the vacuum source via the non-disposable vacuum path. The disposable vacuum path has a first end and a second end, the first end being

configured for removable attachment to the distal end of the non-disposable vacuum path and the second end being coupled in fluid communication with the sample basket. The disposable vacuum path includes a second one-way valve configured and arranged to permit the negative pressure fluid flow toward the vacuum source from the sample basket and to redundantly prevent the positive pressure fluid flow away from the distal end of the non-disposable vacuum path toward the sample basket.

[0009] The invention in another form is directed to a disposable biopsy probe assembly configured for releasable attachment to a driver assembly having an electromechanical power source, a vacuum source, and a first vacuum path permanently associated with the vacuum source. The disposable biopsy probe assembly includes a transmission device, a biopsy probe, a second vacuum path, and a fluid management tank. The transmission device is configured for driving engagement with the electromechanical power source. The biopsy probe is drivably coupled to the transmission device. The biopsy probe has a sample basket for receiving a biopsy tissue sample. The second vacuum path has a first end and a second end, the first end being configured for removable attachment to the first vacuum path and the second end being coupled in fluid communication with the sample basket. The second vacuum path has a one-way valve configured and arranged to permit a negative pressure fluid flow from the sample basket and to prevent a positive pressure fluid flow from the first end of the second vacuum path toward the sample basket. A fluid management tank is fluidically interposed in the second vacuum path between the first end and the second end. The fluid management tank includes a body and a filter arrangement contained within the body configured to prevent a flow of residual biopsy biological material from the sample basket to the

vacuum source with the negative pressure fluid flow. The filter arrangement includes a plurality of fluid absorption layers arranged side by side, each fluid absorption layer being spaced apart from an adjacent fluid absorption layer, and each fluid absorption layer having a respective through opening, wherein adjacent through openings of the plurality of fluid absorption layers are offset to form a tortuous open fluid passageway through the plurality of fluid absorption layers.

[0010] In accordance with one or more aspects of the invention, the fluid connection interface between the driver assembly and the disposable biopsy probe assembly is automatic upon installation of the disposable biopsy probe assembly on the driver assembly. Thus, no specific operator actions are required to establish the connection between the vacuum path of the disposable biopsy probe assembly and the vacuum source of the driver assembly.

[0011] Also, in accordance with one or more aspects of the invention, the biopsy apparatus is provided with multiple levels of prevention of cross-contamination between the non-invasive reusable driver assembly and the disposable biopsy probe assembly. In addition, there is provided multiple levels of prevention of reverse flow (positive pressure flow) from the vacuum source towards the patient. Also, the prevention of cross-contamination is facilitated by having on the disposable biopsy probe assembly a fluid management tank to provide fully enclosed storage of biopsy fluids with reduced risk of post-procedure spillage and multiple stages of absorption of biopsy liquids from vacuum pathway, as well as doing so while permitting 360-degree turnability of the biopsy apparatus without compromising vacuum pathways.

5a

Various aspects of the present invention may relate to a biopsy apparatus, comprising: (a) a driver assembly configured to be grasped by a user, including: an electromechanical power source; a vacuum source; and a first vacuum path permanently associated with said vacuum source, said first vacuum path having a proximal end and a distal end, said proximal end being fixedly coupled to said vacuum source in fluid communication therewith, said first vacuum path having a first one-way valve configured and arranged to permit a negative pressure fluid flow toward said vacuum source and to prevent a positive pressure fluid flow away from said vacuum source toward said distal end; and (b) a disposable biopsy probe assembly configured for releasable attachment to said driver assembly, said disposable biopsy probe assembly including: a transmission device configured to drive engagement with said electromechanical power source; a biopsy probe drivably coupled to said transmission device, said biopsy probe configured to collect a biopsy tissue sample; and a second vacuum path having a first end and a second end, said first end being configured for removable attachment to said distal end of said first vacuum path and said second end being coupled in fluid communication with said sample basket, said second vacuum path having a second one-way valve configured and arranged to permit the negative pressure fluid flow from said sample basket and to redundantly prevent the positive pressure fluid flow from said first end of said second vacuum path toward said sample basket.

Various aspects of the present invention may relate to a fluid management system for use in a biopsy apparatus that utilizes a biopsy probe having a sample basket configured to receive a biopsy tissue sample, comprising: a vacuum source; a non-disposable vacuum path having a proximal end and a distal end, said proximal end being fixedly coupled to said vacuum

5b

source in fluid communication therewith, said non-disposable vacuum path including a first one-way valve configured and arranged to permit a negative pressure fluid flow toward said vacuum source and to prevent a positive pressure fluid flow away from said vacuum source toward said distal end of said non-disposable vacuum path; a disposable vacuum path temporarily coupled in fluid communication with said vacuum source via said non-disposable vacuum path, said disposable vacuum path having a first end and a second end, said first end being configured for removable attachment to said distal end of said non-disposable vacuum path and said second end being coupled in fluid communication with said sample basket, said disposable vacuum path including a second one-way valve configured and arranged to permit the negative pressure fluid flow toward said vacuum source from said sample basket and to redundantly prevent the positive pressure fluid flow away from said distal end of said non-disposable vacuum path toward said sample basket.

Various aspects of the present invention may relate to a disposable biopsy probe assembly configured for releasable attachment to a driver assembly having an electromechanical power source, a vacuum source, and a first vacuum path permanently associated with said vacuum source, said disposable biopsy probe assembly comprising: a transmission device configured for driving engagement with said electromechanical power source; a biopsy probe drivably coupled to said transmission device, said biopsy probe having a sample basket for receiving a biopsy tissue sample; and a second vacuum path having a first end and a second end, said first end being configured for removable attachment to said first vacuum path and said second end being coupled in fluid communication with said sample basket, said second vacuum path having a one-way valve configured and arranged to permit a negative pressure

5c

fluid flow from said sample basket and to prevent a positive pressure fluid flow from said first end of said second vacuum path toward said sample basket; a fluid management tank fluidically interposed in said second vacuum path between said first end and said second end, said fluid management tank including a body and a filter arrangement contained within said body configured to prevent a flow of residual biopsy biological material from said sample basket to said vacuum source with the negative pressure fluid flow, said filter arrangement including a plurality of fluid absorption layers arranged side by side, each fluid absorption layer being spaced apart from an adjacent fluid absorption layer, each fluid absorption layer having a respective through opening, wherein adjacent through openings of said plurality of fluid absorption layers are offset to form a tortuous open fluid passageway through said plurality of fluid absorption layers.

Various aspects of the present invention may relate to a biopsy apparatus, comprising: a driver assembly configured to be grasped by a user, including: an electromechanical power source; a vacuum source; and a first vacuum path permanently associated with said vacuum source, said first vacuum path having a proximal end and a distal end, said proximal end being fixedly coupled to said vacuum source in fluid communication therewith, said first vacuum path having a first one-way valve configured and arranged to permit a negative pressure fluid flow toward said vacuum source and to prevent a positive pressure fluid flow away from said vacuum source toward said distal end; a disposable biopsy probe assembly configured for releasable attachment to said driver assembly, said disposable biopsy probe assembly including: a transmission device configured to drive engagement with said electromechanical power source; a biopsy probe drivably coupled to said transmission device, said biopsy probe having

5d

a sample basket configured to receive a biopsy tissue sample; and a second vacuum path having a first end and a second end, said first end being configured for removable attachment to said distal end of said first vacuum path and said second end being coupled in fluid communication with said sample basket, said second vacuum path having a second one-way valve configured and arranged to permit the negative pressure fluid flow from said sample basket and to redundantly prevent the positive pressure fluid flow from said first end of said second vacuum path toward said sample basket; and a vacuum monitoring mechanism coupled to said vacuum source and configured to shut off said vacuum source when a vacuum level in at least one of said first vacuum path and said second vacuum path reaches a predetermined level.

Various aspects of the present invention may relate to a biopsy apparatus, comprising: a driver assembly configured to be grasped by a user, including: an electromechanical power source; a vacuum source; and a first vacuum path permanently associated with said vacuum source, said first vacuum path having a proximal end and a distal end, said proximal end being fixedly coupled to said vacuum source in fluid communication therewith; a disposable biopsy probe assembly configured for releasable attachment to said driver assembly, said disposable biopsy probe assembly including: a transmission device configured for driving engagement with said electromechanical power source; a biopsy probe drivably coupled to said transmission device, said biopsy probe having a sample basket configured to receive a biopsy tissue sample; a second vacuum path having a first end and a second end, said first end being configured for removable attachment to said distal end of said first vacuum path and said second end being coupled in fluid communication with said sample basket; and a fluid management tank

5e

fluidically interposed in said second vacuum path between said first end and said second end, said fluid management tank including body and a filter arrangement contained within the body configured to prevent a flow of residual biopsy biological material from said sample basket to said vacuum source; and a vacuum monitoring mechanism coupled to said vacuum source and configured to shut off said vacuum source when a volume of fluid flow through said fluid management tank is reduced to a predetermined level.

Various aspects of the present invention may relate to a fluid management system for use in a biopsy apparatus that utilizes a biopsy probe having a sample basket configured to receive a biopsy tissue sample, comprising: a vacuum source; a non-disposable vacuum path having a proximal end and a distal end; a disposable vacuum path in fluid communication with said sample basket, and temporarily coupled in fluid communication with said vacuum source via said non-disposable vacuum path, said disposable vacuum path having a first end and a second end; a fluid management tank fluidically interposed in said disposable vacuum path between said first end and said second end, said fluid management tank configured to prevent a flow of residual biopsy biological material from said sample basket to said vacuum source; and a vacuum monitoring mechanism coupled to said vacuum source and configured to shut off said vacuum source when a fluid flow volume through said fluid management tank is reduced to a predetermined level.

Various aspects of the present invention may relate to a biopsy apparatus, comprising: a driver assembly configured to be grasped by a user, including: an electromechanical power source; a vacuum source; and a first vacuum path permanently associated with said vacuum

5f

source, said first vacuum path having a proximal end and a distal end, said proximal end being fixedly coupled to said vacuum source in fluid communication therewith, said first vacuum path having a first one-way valve configured and arranged to permit a negative pressure fluid flow toward said vacuum source and to prevent a positive pressure fluid flow away from said vacuum source toward said distal end; and a disposable biopsy probe assembly configured for releasable attachment to said driver assembly, said disposable biopsy probe assembly including: a transmission device configured to drive engagement with said electromechanical power source; a biopsy probe drivably coupled to said transmission device, said biopsy probe having a sample basket configured to receive a biopsy tissue sample; a second vacuum path having a first end and a second end, said first end being configured for removable attachment to said distal end of said first vacuum path and said second end being coupled in fluid communication with said sample basket, said second vacuum path having a second one-way valve configured and arranged to permit the negative pressure fluid flow from said sample basket and to redundantly prevent the positive pressure fluid flow from said first end of said second vacuum path toward said sample basket; and a fluid management tank fluidically interposed in said second vacuum path between said first end and said second end, said fluid management tank including body and a filter arrangement contained within the body configured to prevent a flow of residual biopsy biological material from said sample basket to said vacuum source.

Various aspects of the present invention may relate to a fluid management tank for use in a biopsy apparatus having a vacuum source in fluid communication with a sample

5g

basket, comprising: a body; and a filter arrangement contained within the body configured to prevent a flow of residual biopsy biological material from said sample basket to said vacuum source, wherein said filter arrangement includes: a plurality of fluid absorption layers arranged side by side, each fluid absorption layer being spaced apart from an adjacent fluid absorption layer, each fluid absorption layer having a respective through opening, wherein adjacent through openings of said plurality of fluid absorption layers are offset to form a tortuous open fluid passageway through said plurality of fluid absorption layers.

Various aspects of the present invention may relate to a fluid management system for use in a biopsy apparatus that utilizes a biopsy probe having a sample basket configured to receive a biopsy tissue sample, comprising: a vacuum source; a non-disposable vacuum path having a proximal end and a distal end; a disposable vacuum path in fluid communication with said sample basket, and temporarily coupled in fluid communication with said vacuum source via said non-disposable vacuum path, said disposable vacuum path having a first end and a second end; a fluid management tank fluidically interposed in said disposable vacuum path between said first end and said second end, said fluid management tank including a filter arrangement configured to prevent a flow of residual biopsy biological material from said sample basket to said vacuum source; and a vacuum monitoring mechanism coupled to said vacuum source and configured to shut off said vacuum source when a restriction is detected in said fluid management tank.

BRIEF DESCRIPTION OF THE DRAWINGS

[0012] The above-mentioned and other features and advantages of this invention, and the manner of attaining them, will become more apparent and the invention will be better understood by reference to the following description of an embodiment of the invention taken in conjunction with the accompanying drawings, wherein:

[0013] Fig. 1 is a perspective view of a biopsy apparatus, configured in accordance with an embodiment of the present invention, with a disposable biopsy probe mounted to a driver assembly;

[0014] Fig. 2 is a perspective view of a biopsy apparatus of Fig. 1, with the disposable biopsy probe detached from the driver assembly;

[0015] Fig. 3 is a schematic representation of the biopsy apparatus of Fig. 1;

[0016] Fig. 4A is a perspective view of a vacuum seal element of the vacuum path of the driver assembly of Fig. 3;

[0017] Fig. 4B is a perspective view of a vacuum seal element of the vacuum path of the disposable biopsy probe of Fig. 3;

[0018] Fig. 5A is a perspective view of the fluid management tank of the disposable biopsy probe shown in Figs. 2 and 3, with a portion broken away to expose a filter arrangement;

[0019] Fig. 5B is an exploded view of a plurality of fluid absorption layers of the filter arrangement of Fig. 5A; and

[0020] Fig. 5C is a perspective view of a porous filter element of the filter arrangement of Fig. 5A.

[0021] Corresponding reference characters indicate corresponding parts throughout the several views. The exemplifications set out herein illustrate an embodiment of the

invention, and such exemplifications are not to be construed as limiting the scope of the invention in any manner.

DETAILED DESCRIPTION OF THE INVENTION

[0022] Referring now to the drawings, and more particularly to Figs. 1 and 2, there is shown a biopsy apparatus 10 which generally includes a non-invasive, e.g., non-disposable, driver assembly 12 and a disposable biopsy probe assembly 14.

[0023] Referring also to Fig. 3, driver assembly 12 and disposable biopsy probe assembly 14 collectively include a fluid management system 16 that includes a vacuum source 18, first vacuum path 20 and a second vacuum path 22. Vacuum source 18 and a first vacuum path 20 are permanently associated with driver assembly 12, and a second vacuum path 22 is permanently associated with disposable biopsy probe assembly 14, as more fully described below, to help facilitate the safe and effective collection of a biopsy tissue sample.

[0024] As used herein, the term “non-disposable” is used to refer to a device that is intended for use on multiple patients during the lifetime of the device, and the term “disposable” is used to refer to a device that is intended to be disposed of after use on a single patient. Also, the term “vacuum path” means a fluid passageway used to facilitate a vacuum between two points, the fluid passageway passing through one or more components, such as for example, one or more of tubing, conduits, couplers, and interposed devices. Also, the term “permanently associated” means a connection that is not intended for releasable attachment on a routine basis during the lifetime of the components. Thus, for example, driver assembly 12 including vacuum source 18 and

first vacuum path 20 is reusable as a unit in its entirety, whereas disposable biopsy probe assembly 14 and second vacuum path 22 are disposable as a unit in its entirety.

[0025] Driver assembly 12 includes a housing 24 configured, and ergonomically designed, to be grasped by a user. Driver assembly 12 includes (contained within housing 24) vacuum source 18, first vacuum path 20, a controller 26, an electromechanical power source 28, and a vacuum monitoring mechanism 30. A user interface 32 is located to be mounted to, and externally accessible with respect to, housing 24.

[0026] Controller 26 is communicatively coupled to electromechanical power source 28, vacuum source 18, user interface 32, and vacuum monitoring mechanism 30. Controller 26 may include, for example, a microprocessor and associated memory for executing program instructions to perform functions associated with the retrieval of biopsy tissue samples, such as controlling one or more components of vacuum source 18 and electromechanical power source 28. Controller 26 also may execute program instructions to monitor one or more conditions and/or positions of components of biopsy apparatus 10, and to monitor the status of fluid management system 16 associated with driver assembly 12 and disposable probe assembly 14.

[0027] The user interface 32 includes control buttons 321 and visual indicators 322, with control buttons 321 providing user control over various functions of biopsy apparatus 10, and visual indicators 322 providing visual feedback of the status of one or more conditions and/or positions of components of biopsy apparatus 10.

[0028] The electromechanical power source 28 may include, for example, an electrical energy source, e.g., battery, 34 and an electrical drive assembly 36. Battery 34 may be, for example, a rechargeable battery. Battery 34 provides electrical power

to all electrically powered components in biopsy device 10, and thus for simplicity in the drawings, such electrical couplings are not shown. For example, battery 34 is electrically coupled to vacuum source 18, controller 26, user interface 32 and electrical drive assembly 36.

[0029] In the present embodiment, electrical drive assembly 36 includes a first drive 361 and a second drive 362, each being respectively coupled to battery 34, and each of first drive 361 and second drive 362 respectively electrically and controllably coupled to user interface 32.

[0030] First drive 361 may include an electrical motor 381 and a motion transfer unit 401 (shown schematically by a line). Second drive 362 may include an electrical motor 382 and a motion transfer unit 402 (shown schematically by a line). Each electrical motor 381, 382 may be, for example, a direct current (DC) motor, stepper motor, etc. Motion transfer unit 401 of first drive 361 may be configured, for example, with a rotational-to-linear motion converter, such as a worm gear arrangement, rack and pinion arrangement, solenoid-slide arrangement, etc. Motion transfer unit 402 of second drive 362 may be configured to transmit rotary motion. Each of first drive 361 and second drive 362 may include one or more of a gear, gear train, belt/pulley arrangement, etc.

[0031] Vacuum source 18 is electrically coupled to battery 34, and has a vacuum source port 181 for establishing a vacuum. Vacuum source 18 is electrically and controllably coupled to user interface 32. Vacuum source 18 may further include, for example, a vacuum pump 182 driven by an electric motor 183. Vacuum pump 182 may be, for example, a peristaltic pump, a diaphragm pump, syringe-type pump, etc.

[0032] First vacuum path 20 of driver assembly 12 is permanently associated with vacuum source 18. First vacuum path 20, also sometimes referred to as a non-disposable vacuum path, has a proximal end 201 and a distal end 202, and includes, for example, conduits 203, a first one-way valve 204, and a particulate filter 205. Proximal end 201 is fixedly coupled to vacuum source 18 in fluid communication therewith, e.g., is fixedly connected to vacuum source port 181 of vacuum source 18. Referring also to Fig. 4A, distal end 202 includes a first vacuum seal element 206. In the present embodiment, first vacuum seal element 206 is a planar abutment surface that surrounds a first passageway 207 of first vacuum path 20.

[0033] First one-way valve 204 is configured and arranged to permit a negative pressure fluid flow toward vacuum source 18 and to prevent a positive pressure fluid flow away from vacuum source 18 toward the distal end 202 of first vacuum path 20. The first one-way valve 204 may be, for example, a check-valve, such as a ball valve or reed valve, that opens with a fluid flow toward vacuum source 18, and closes in the case of a reverse (positive) flow away from vacuum source 18.

[0034] In the present embodiment, particulate filter 205 is located between vacuum source 18 and distal end 202 of first vacuum path 20. Particulate filter 205 may be, for example, a mesh screen formed from metal or plastic. However, it is contemplated that particulate filter 205 may be located in fluid management system 16 between vacuum source 18 and a vacuum receiving component of biopsy probe assembly 14.

[0035] The vacuum monitoring mechanism 30 is coupled to vacuum source 18 to shut off vacuum source 18 when a sensed vacuum level has fallen below a threshold level. Vacuum monitoring mechanism 30 may include, for example, a vacuum

monitor and control program executing on controller 26, and a pressure sensor 301 coupled to controller 26, and in fluid communication with first vacuum path 20 for detecting a pressure in first vacuum path 20. If, for example, the vacuum flow level in first vacuum path 20 falls below a predetermined level, indicating a restriction in fluid management system 16, controller 26 may respond by shutting off vacuum source 18, e.g., turning off electric motor 183. Alternatively, controller 26 may monitor the current supplied to electric motor 183, and if the current exceeds a predetermined amount, indicating a restriction in fluid management system 16, controller 26 may respond by shutting off vacuum source 18, e.g., turning off electric motor 183.

[0036] The disposable biopsy probe assembly 14 is configured for releasable attachment to driver assembly 12. As used herein, the term “releasable attachment” means a configuration that facilitates an intended temporary connection followed by selective detachment involving a manipulation of disposable biopsy probe assembly 14 relative to driver assembly 12, without the need for tools.

[0037] The disposable biopsy probe assembly 14 includes a frame 141 to which a transmission device 42, a biopsy probe 44, and the second vacuum path 22 are mounted. Biopsy probe 44 is drivably coupled to transmission device 42, and transmission device 42 is drivably coupled to electromechanical power source 28 of driver assembly 12.

[0038] In the embodiment shown, transmission device 42 includes a first driven unit 421 and a second driven unit 422 that are drivably engaged with various components of biopsy probe 44. Also, first driven unit 421 is drivably engaged with first drive 361 of electrical drive assembly 36 of driver assembly 12. Second driven unit 422 is

drivably engaged with second drive 362 of electrical drive assembly 36 of driver assembly 12.

[0039] In the embodiment shown (see, e.g., Figs. 1-3), biopsy probe 44 includes a sample basket 441 and a cutter cannula 442. Sample basket 441 has a sharpened tip 443 to aid in puncturing tissue and has a sample notch 444 in the form of a recessed region for receiving a biopsy tissue sample.

[0040] In operation, cutter cannula 442 is linearly driven by first driven unit 421 to traverse over sample notch 444 of sample basket 441. For example, first driven unit 421 may be in the form of a linear slide that is drivably engaged with first drive 361 of driver assembly 12, which in turn drives cutter cannula 442 in a first direction 46 to expose sample notch 444 of sample basket 441, and drives cutter cannula 442 in a second direction 48 opposite to first direction 46 to sever tissue prolapsed into sample notch 444. Also, first driven unit 421 and second driven unit 422 may be configured to operate in unison to advance both sample basket 441 and cutter cannula 442 in unison in a piercing shot operation to aid in inserting biopsy probe 44 into fibrous tissue.

[0041] The second driven unit 422 may include a flexible toothed rack 50 and a gear train 52. Flexible toothed rack 50 is connected to sample basket 441, and gear train 52 is engaged with the teeth of flexible toothed rack 50. In operation, second drive 362 transfers rotary motion to gear train 52, and in turn gear train 52 engages flexible toothed rack 50 to move sample basket 441 linearly to transport the tissue captured in sample notch 444 out of the body of the patient. Flexible toothed rack 50 is received in a coiling unit 54 when retracting, thereby enabling substantial reduction in the overall device length of biopsy apparatus 10 as compared to a rigid capture

system. The severed tissue sample is transported out of the body of the patient and into tissue sample chamber 56 (mounted to frame 141), which scoops the tissue sample out of sample notch 444.

[0042] In the present embodiment, the second vacuum path 22, also sometimes referred to as a disposable vacuum path 22, has a first end 221 and a second end 222, and includes for example, conduits 223, a second one-way valve 224, and a fluid management tank 225. The first end 221 is configured for removable attachment to the distal end 202 of the first vacuum path 20 of driver assembly 12. The second end 222 is coupled in fluid communication with sample basket 441, and more particularly, is coupled in fluid communication with sample notch 444 of sample basket 441.

[0043] Referring also to Fig. 4B, the first end 221 of the disposable vacuum path 22 includes a second vacuum seal element 226. The first vacuum seal element 206 of the driver assembly 12 contacts the second vacuum seal element 226 of the disposable biopsy probe assembly 14 in sealing engagement when the disposable biopsy probe assembly 14 is attached to driver assembly 12. The second vacuum seal element 226 is a compliant, e.g., rubber, annular member that surrounds a second passageway 227 of the second vacuum path 22.

[0044] The second one-way valve 224 is configured and arranged to permit the negative pressure fluid flow from sample basket 441 toward the first end 221 of the second vacuum path 22, and to redundantly (in conjunction with first one-way valve 204 of driver assembly 12) prevent any positive pressure fluid flow in a direction from the first end 221 of the second vacuum path 22 toward sample basket 441. In other words, the second one-way valve 224 provides a redundant second level of protection in preventing any positive pressure from reaching sample notch 444 of

sample basket 441. In the present embodiment, the second one-way valve 224 may be, for example, a duckbill valve, e.g., a reed-type valve, that opens with a fluid flow out the bill portion of the duckbill valve, and closes with a reverse flow. As shown, the second one-way valve 224 may be positioned within the second vacuum seal element 226 at first end 221 of second vacuum path 22.

[0045] Referring also to Fig. 5A, fluid management tank 225 is fluidically interposed in the second vacuum path 22 between the first end 221 and the second end 222. Fluid management tank 225 includes a body 58 and a filter arrangement 60 contained within body 58 configured to prevent a flow of residual biopsy biological material, e.g., blood and particulate matter, from sample notch 444 of sample basket 441 to vacuum source 18 of driver assembly 12.

[0046] Body 58 of fluid management tank 225 has a first port 581 and a second port 582, with the second vacuum path 22 continuing between the first port 581 and the second port 582. The second port 582 of fluid management tank 225 is coupled to sample basket 441. Each of the second one-way valve 224 and the second vacuum seal element 226 of the second vacuum path 22 is coupled to the first port 581 of fluid management tank 225, and in the present embodiment, is mounted to an external surface of body 58 of fluid management tank 225.

[0047] As illustrated in Figs. 5A and 5B, filter arrangement 60 includes a plurality of fluid absorption layers 62, individually identified as layers 621, 622, 623 and 624, arranged side by side, with each fluid absorption layer 621, 622, 623 and 624 being spaced apart from an adjacent fluid absorption layer e.g., 621 to 622, 622 to 623, 623, to 624. Each fluid absorption layer 621, 622, 623 and 624 has a respective through opening 641, 642, 643, 644, wherein adjacent through openings of through openings

641, 642, 643, 644 of the plurality of fluid absorption layers 62 are offset one to the next, e.g., in at least one of an X, Y, and Z direction, to form a tortuous open fluid passageway 66 through the plurality of fluid absorption layers 62. Each fluid absorption layer 621, 622, 623 and 624 may be, for example, a blotting paper.

[0048] As illustrated in Figs. 5A and 5C, filter arrangement 60 may further include a porous filter element 68 arranged to be fluidically in series with the plurality of fluid absorption layers 62 along the second vacuum path 22 that defines second passageway 227. The porous filter element 68 exhibits increased restriction to fluid flow as an increased number of pores 70 in the porous filter element 68 become clogged by residual biopsy biological material, such as blood and tissue particles. When a volume of the fluid flow through fluid management tank 225 has been reduced to a predetermined level, vacuum monitoring mechanism 30 senses the vacuum restriction, and controller 26 responds to shut off vacuum source 18.

[0049] While this invention has been described with respect to at least one embodiment, the present invention can be further modified within the spirit and scope of this disclosure. This application is therefore intended to cover any variations, uses, or adaptations of the invention using its general principles. Further, this application is intended to cover such departures from the present disclosure as come within known or customary practice in the art to which this invention pertains and which fall within the limits of the appended claims.

WHAT IS CLAIMED IS:

1. A biopsy apparatus, comprising:
 - (a) a driver assembly configured to be grasped by a user, including:
 - an electromechanical power source;
 - a vacuum source; and
 - a first vacuum path permanently associated with said vacuum source, said first vacuum path having a proximal end and a distal end, said proximal end being fixedly coupled to said vacuum source in fluid communication therewith, said first vacuum path having a first one-way valve configured and arranged to permit a negative pressure fluid flow toward said vacuum source and to prevent a positive pressure fluid flow away from said vacuum source toward said distal end; and
 - (b) a disposable biopsy probe assembly configured for releasable attachment to said driver assembly, said disposable biopsy probe assembly including:
 - a transmission device configured to drive engagement with said electromechanical power source;
 - a biopsy probe drivably coupled to said transmission device, said biopsy probe configured to collect a biopsy tissue sample; and
 - a second vacuum path having a first end and a second end, said first end being configured for removable attachment to said distal end of said first vacuum path and said second end being coupled in fluid communication with said sample basket, said second vacuum path having a second one-way valve configured and arranged to permit the negative pressure fluid flow from said sample basket and to

redundantly prevent the positive pressure fluid flow from said first end of said second vacuum path toward said sample basket.

2. The biopsy apparatus of claim 1, wherein:

said distal end of said first vacuum path includes a first vacuum seal element; and

said first end of said second vacuum path includes a second vacuum seal element, said first vacuum seal element contacting said second vacuum seal element in sealing engagement simultaneously with said disposable biopsy probe assembly being attached to said driver assembly, said second one-way valve being positioned within said second vacuum seal element.

3. The biopsy apparatus of claim 2, wherein the first vacuum seal element is a planar abutment surface that surrounds a first passageway of said first vacuum path, and said second vacuum seal element is a compliant annular member that surrounds a second passageway of the second vacuum path, said compliant annular member of said second vacuum seal element configured to contact said planar abutment surface of said first vacuum seal element in sealing engagement.

4. The biopsy apparatus of claim 1, said disposable biopsy probe assembly including a fluid management tank fluidically interposed in said second vacuum path between said first end and said second end, said fluid management tank including body and a filter arrangement contained within the body configured to prevent a flow of residual biopsy biological material from said sample basket to said vacuum source.

5. The biopsy apparatus of claim 4, further comprising:
said biopsy probe having a sample basket for receiving said biopsy tissue sample;
a first vacuum seal element located at said distal end of said first vacuum path
a second vacuum seal element located at the first end of said second vacuum path,
said first vacuum seal element contacting said second vacuum seal element in sealing
engagement when said disposable biopsy probe assembly is attached to said driver
assembly; and
said body of said fluid management tank having a first port and a second port, said
second vacuum path continuing between said first port and said second port, said second
port being coupled to said sample basket; and
each of said second one-way valve and said second vacuum seal being coupled to
said first port and mounted to an external surface of said body of said fluid management
tank.

6. The biopsy apparatus of claim 4, wherein said filter arrangement includes a
plurality of fluid absorption layers arranged side by side, each fluid absorption layer being
spaced apart from an adjacent fluid absorption layer, each fluid absorption layer having a
respective through opening, wherein adjacent through openings of said plurality of fluid
absorption layers are offset to form a tortuous open fluid passageway through said plurality
of fluid absorption layers.

7. The biopsy apparatus of claim 6, wherein said filter arrangement further
includes a porous filter element arranged to be fluidically in series with said plurality of

fluid absorption layers along said second vacuum path, wherein said porous filter element exhibits increased restriction to fluid flow as an increased number of pores in said porous filter element become clogged by residual biopsy biological material.

8. The biopsy apparatus of claim 7, further comprising a vacuum monitoring mechanism coupled to said vacuum source to shut off said vacuum source when a volume of said fluid flow through said fluid management tank has been reduced to a predetermined level.

9. The biopsy apparatus of claim 8, wherein said vacuum monitoring mechanism includes a pressure sensor in fluid communication with said first vacuum path.

10. The biopsy apparatus of claim 4, further comprising a particulate filter located between said vacuum source and said distal end of said first vacuum path.

11. A biopsy apparatus, comprising:

(a) a driver assembly configured to be grasped by a user, including:

- an electromechanical power source;
- a vacuum source; and
- a first vacuum path permanently associated with said vacuum source, said first vacuum path having a proximal end and a distal end, said proximal end being fixedly coupled to said vacuum source in fluid communication therewith, said first vacuum path having a first one-way valve configured and arranged to permit a negative

pressure fluid flow toward said vacuum source and to prevent a positive pressure fluid flow away from said vacuum source toward said distal end;

(b) a disposable biopsy probe assembly configured for releasable attachment to said driver assembly, said disposable biopsy probe assembly including:

a transmission device configured to drive engagement with said electromechanical power source;

a biopsy probe drivably coupled to said transmission device, said biopsy probe having a sample basket configured to receive a biopsy tissue sample; and

a second vacuum path having a first end and a second end, said first end being configured for removable attachment to said distal end of said first vacuum path and said second end being coupled in fluid communication with said sample basket, said second vacuum path having a second one-way valve configured and arranged to permit the negative pressure fluid flow from said sample basket and to redundantly prevent the positive pressure fluid flow from said first end of said second vacuum path toward said sample basket; and

(c) a vacuum monitoring mechanism coupled to said vacuum source and configured to shut off said vacuum source when a vacuum level in at least one of said first vacuum path and said second vacuum path reaches a predetermined level.

12. The biopsy apparatus of claim 11, said vacuum monitoring mechanism comprising:

a controller configured to execute a vacuum monitor and control program;

a pressure sensor coupled to said controller, said pressure sensor coupled in fluid communication with said first vacuum path and configured to detect a pressure in said first vacuum path,

said controller configured to shut off said vacuum source if a vacuum flow pressure indicates a restriction in one of said first vacuum path and said second vacuum path.

13. The biopsy apparatus of claim 11, comprising a fluid management tank fluidically interposed in said second vacuum path between said first end and said second end, said fluid management tank configured to prevent a flow of residual biopsy biological material from said sample basket to said vacuum source, and said vacuum monitoring mechanism configured to shut off said vacuum source when a volume of fluid flow through said fluid management tank has been reduced to a predetermined level.

14. The biopsy apparatus of claim 13, wherein:

said distal end of said first vacuum path includes a first vacuum seal element; and

said first end of said second vacuum path includes a second vacuum seal element, said first vacuum seal element contacting said second vacuum seal element in sealing engagement as said disposable biopsy probe assembly is attached to said driver assembly, said second one-way valve being positioned within said second vacuum seal element.

15. The biopsy apparatus of claim 14, said body of said fluid management tank having a first port and a second port, said second vacuum path continuing between said first port and said second port, said second port being coupled to said sample basket; and

each of said second one-way valve and said second vacuum seal being coupled to said first port and mounted to an external surface of said body of said fluid management tank.

16. The biopsy apparatus of claim 11, further comprising a particulate filter located between said vacuum source and said distal end of said first vacuum path.

17. A biopsy apparatus, comprising:

(a) a driver assembly configured to be grasped by a user, including:

an electromechanical power source;

a vacuum source; and

a first vacuum path permanently associated with said vacuum source, said first vacuum path having a proximal end and a distal end, said proximal end being fixedly coupled to said vacuum source in fluid communication therewith, said first vacuum path having a first one-way valve configured and arranged to permit a negative pressure fluid flow toward said vacuum source and to prevent a positive pressure fluid flow away from said vacuum source toward said distal end; and

(b) a disposable biopsy probe assembly configured for releasable attachment to said driver assembly, said disposable biopsy probe assembly including:

a transmission device configured to drive engagement with said electromechanical power source;

a biopsy probe drivably coupled to said transmission device, said biopsy probe having a sample basket configured to receive a biopsy tissue sample;

a second vacuum path having a first end and a second end, said first end being configured for removable attachment to said distal end of said first vacuum path and said second end being coupled in fluid communication with said sample basket, said second vacuum path having a second one-way valve configured and arranged to permit the negative pressure fluid flow from said sample basket and to redundantly prevent the positive pressure fluid flow from said first end of said second vacuum path toward said sample basket; and

a fluid management tank fluidically interposed in said second vacuum path between said first end and said second end, said fluid management tank including body and a filter arrangement contained within the body configured to prevent a flow of residual biopsy biological material from said sample basket to said vacuum source.

18. The biopsy apparatus of claim 17, wherein said filter arrangement includes a plurality of fluid absorption layers arranged side by side, each fluid absorption layer being spaced apart from an adjacent fluid absorption layer, each fluid absorption layer having a respective through opening, wherein adjacent through openings of said plurality of fluid absorption layers are offset to form a tortuous open fluid passageway through said plurality of fluid absorption layers from one fluid absorption layer to a next fluid absorption layer.

19. The biopsy apparatus of claim 18, wherein said filter arrangement further includes a porous filter element arranged to be fluidically in series with said plurality of fluid absorption layers along said second vacuum path, wherein said porous

filter element exhibits increased restriction to fluid flow as an increased number of pores in said porous filter element become clogged by residual biopsy biological material.

20. The biopsy apparatus of claim 19, comprising a vacuum monitoring mechanism coupled to said vacuum source to shut off said vacuum source when a volume of said fluid flow through said fluid management tank has been reduced to a predetermined level.

21 The biopsy apparatus of claim 20, wherein said vacuum monitoring mechanism includes a pressure sensor in fluid communication with said first vacuum path.

22 The biopsy apparatus of claim 17, wherein said filter arrangement includes a plurality of fluid absorption layers arranged side by side in a first direction, each fluid absorption layer being spaced apart from an adjacent fluid absorption layer in the first direction, said plurality of fluid absorption layers includes a first fluid absorption layer having a first through opening and a third fluid absorption layer having a third through opening, and wherein the first through opening and the third through opening are aligned along a fluid passageway in a direction transverse to the first direction, and wherein a second fluid absorption layer of the plurality of fluid absorption layers is interposed in the fluid passageway between the first through opening and the third through opening in the direction transverse to the first direction.

23 The biopsy apparatus of claim 17, comprising a particulate filter located between said vacuum source and said distal end of said first vacuum path.

24. The biopsy apparatus of claim 17, comprising:
a first vacuum seal element located at said distal end of said first vacuum path
a second vacuum seal element located at the first end of said second vacuum path,
said first vacuum seal element contacting said second vacuum seal element in sealing engagement when said disposable biopsy probe assembly is attached to said driver assembly; and

said body of said fluid management tank having a first port and a second port, said second vacuum path continuing between said first port and said second port, said second port being coupled to said sample basket; and

each of said second one-way valve and said second vacuum seal being coupled to said first port and mounted to an external surface of said body of said fluid management tank.

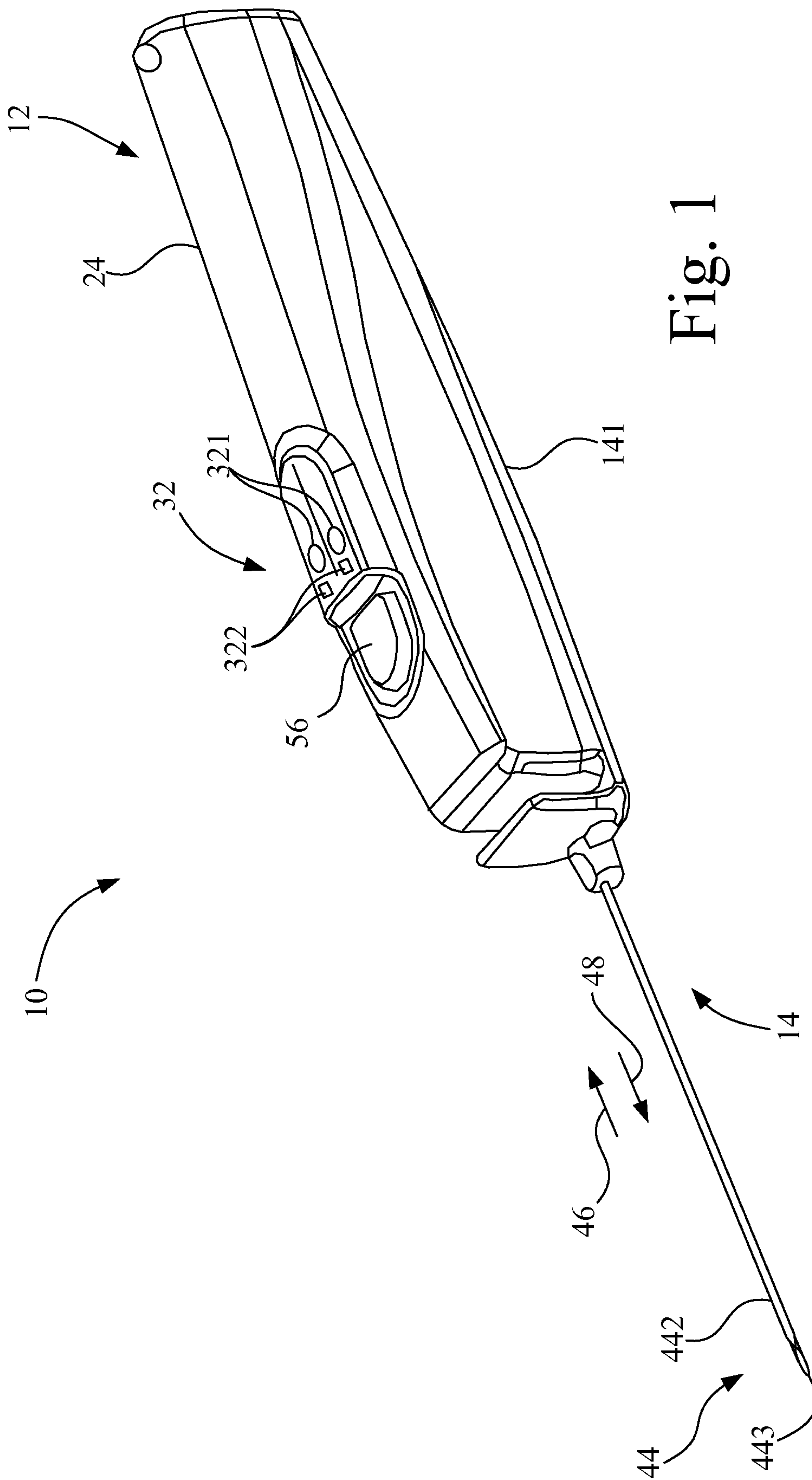

Fig. 1

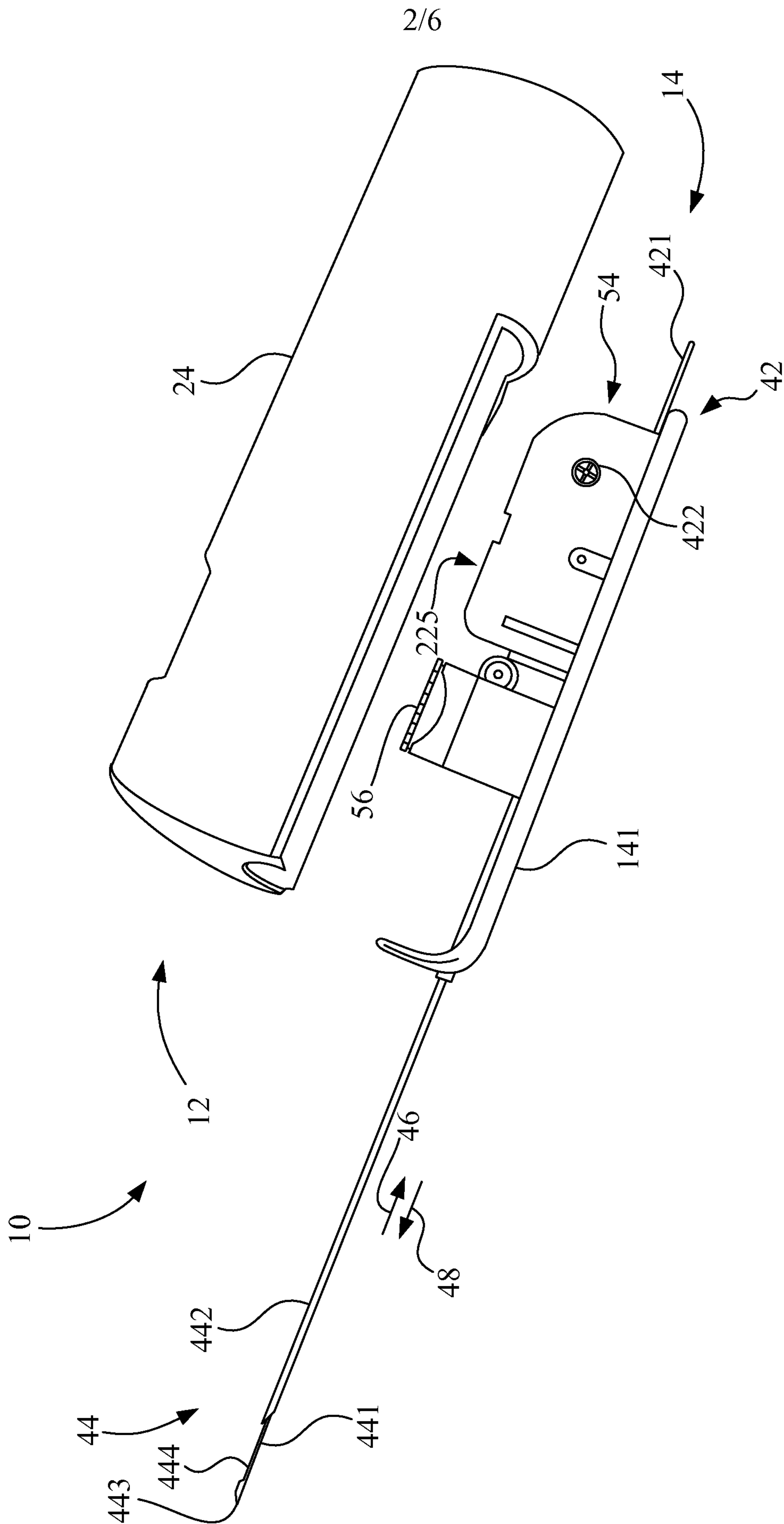

Fig. 2

4/6

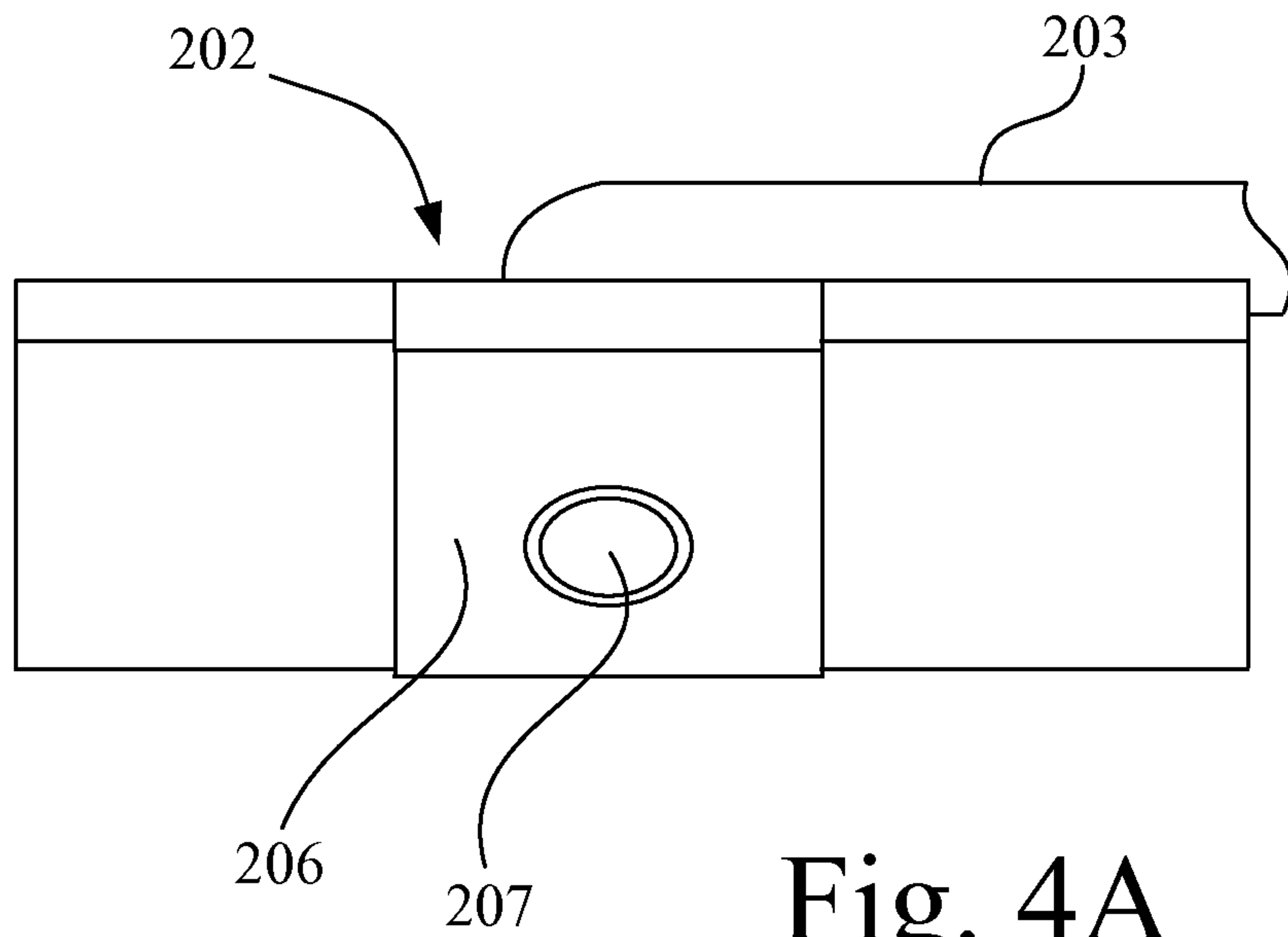

Fig. 4A

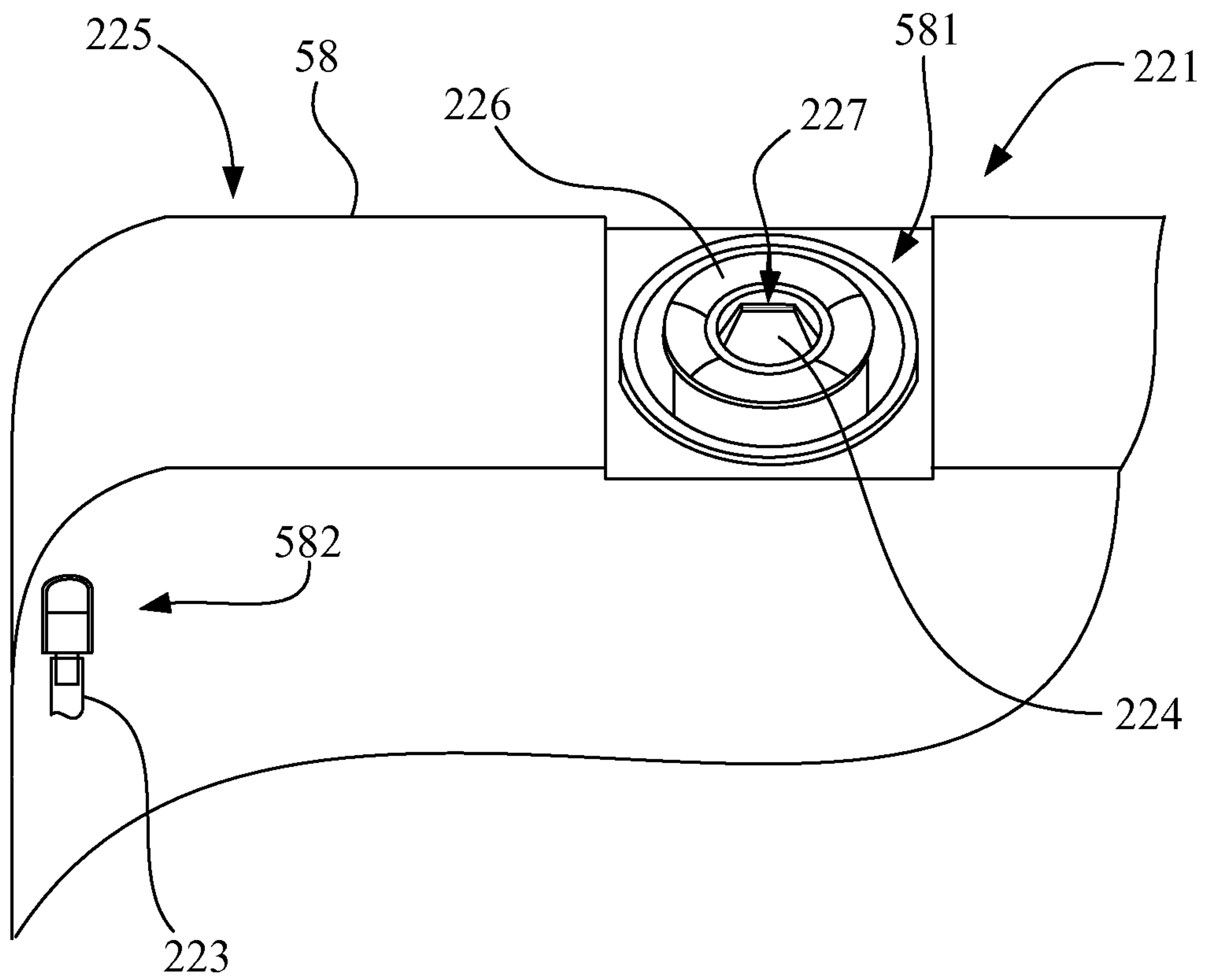

Fig. 4B

5/6

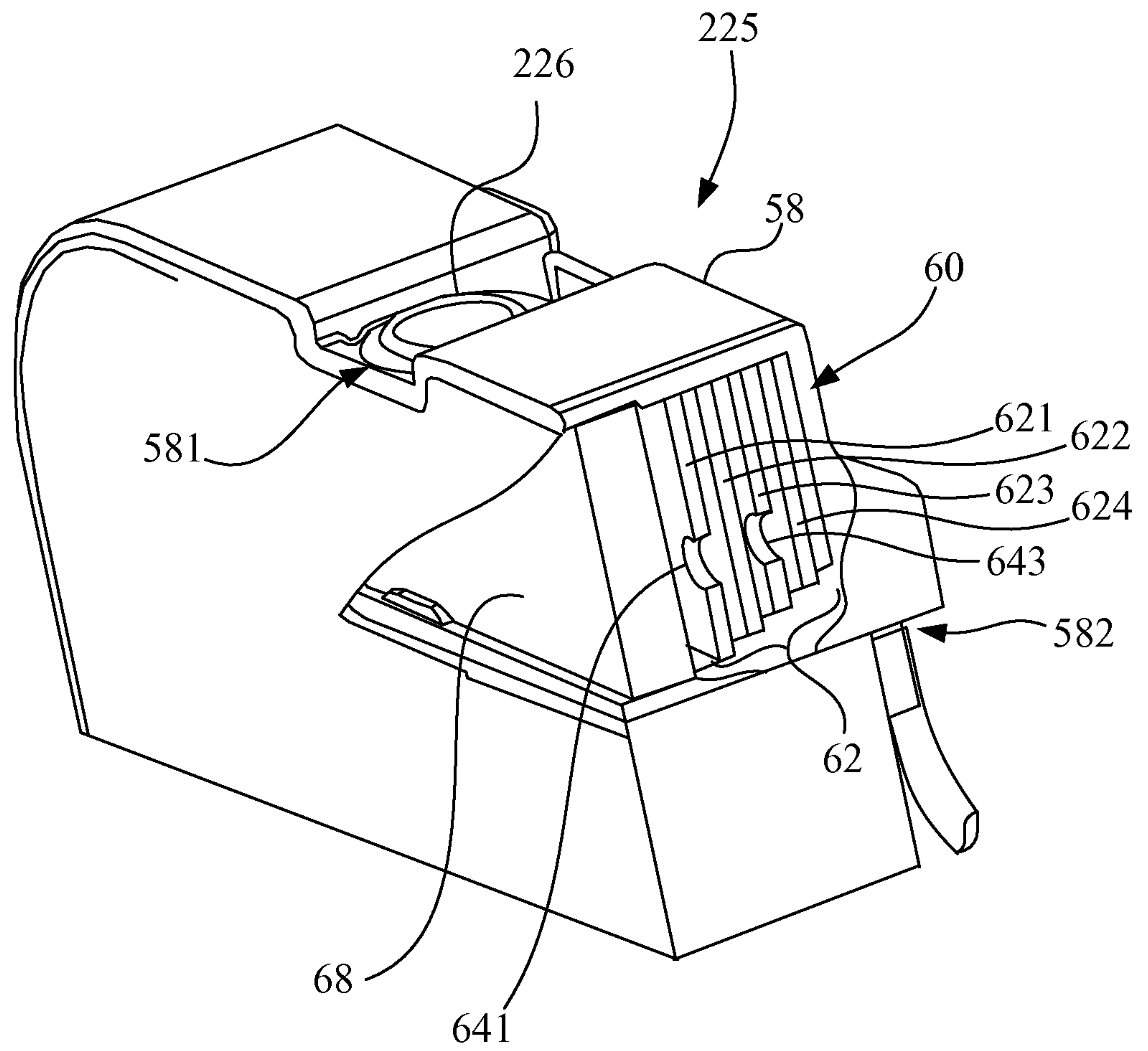

Fig. 5A

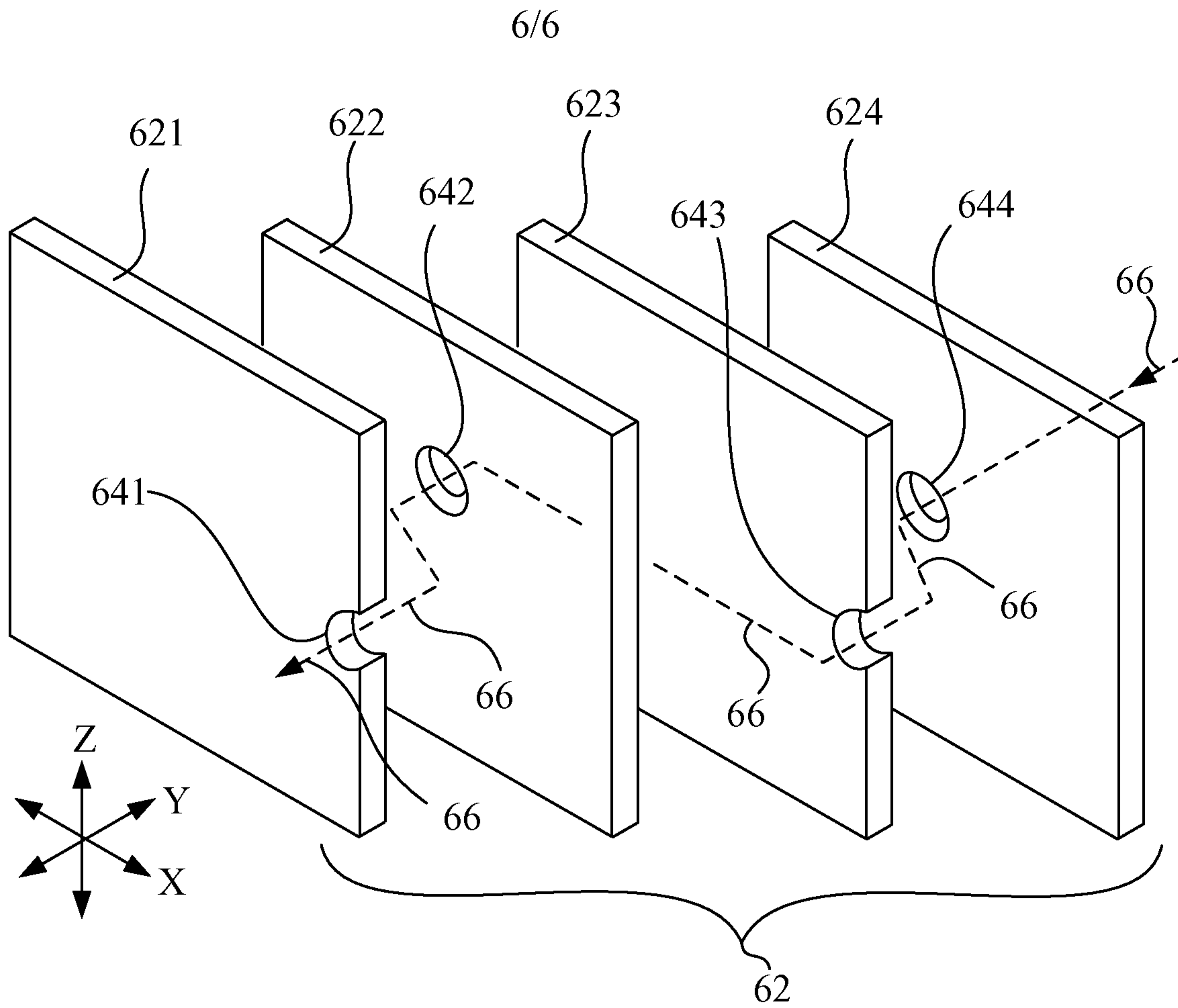

Fig. 5B

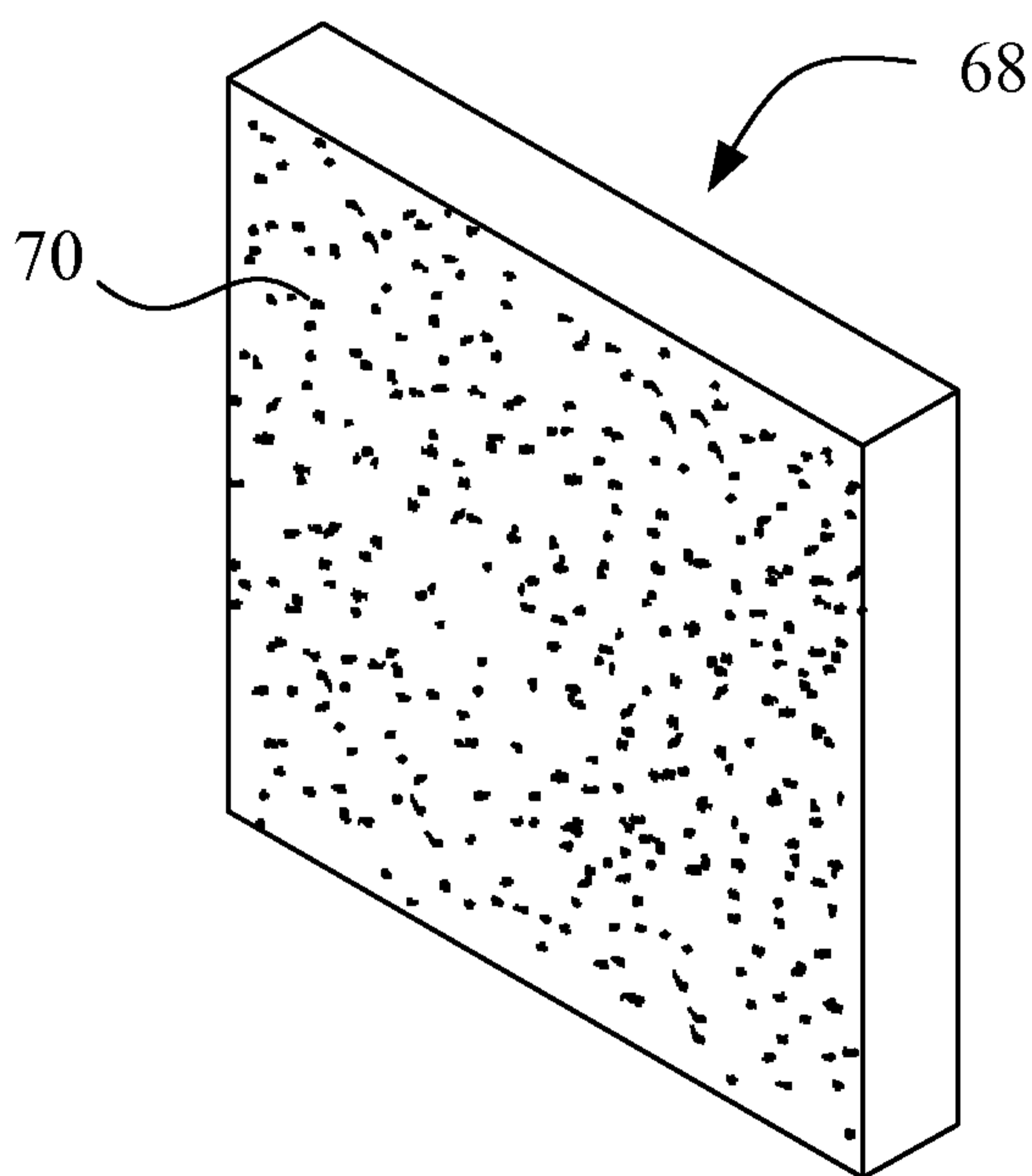

Fig. 5C

