

July 5, 1949.

W. A. CREWS

2,475,562

CLOSURE APPARATUS FOR TANKS AND THE LIKE

Filed Feb. 6, 1947

2 Sheets-Sheet 1

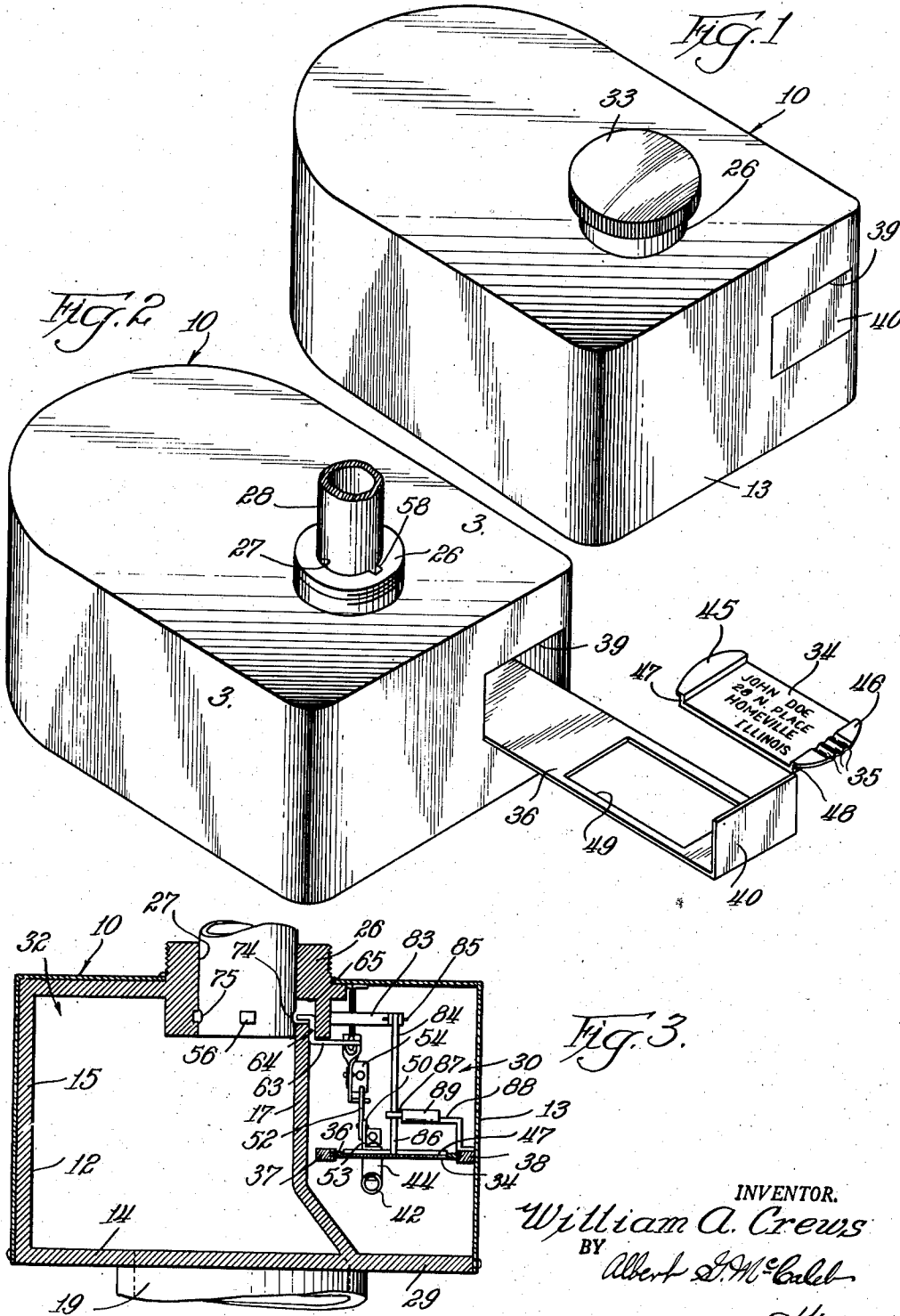

INVENTOR.
William A. Crews
BY *Albert D. McCall*
Att'y.

July 5, 1949.

W. A. CREWS

2,475,562

CLOSURE APPARATUS FOR TANKS AND THE LIKE

Filed Feb. 6, 1947

2 Sheets-Sheet 2

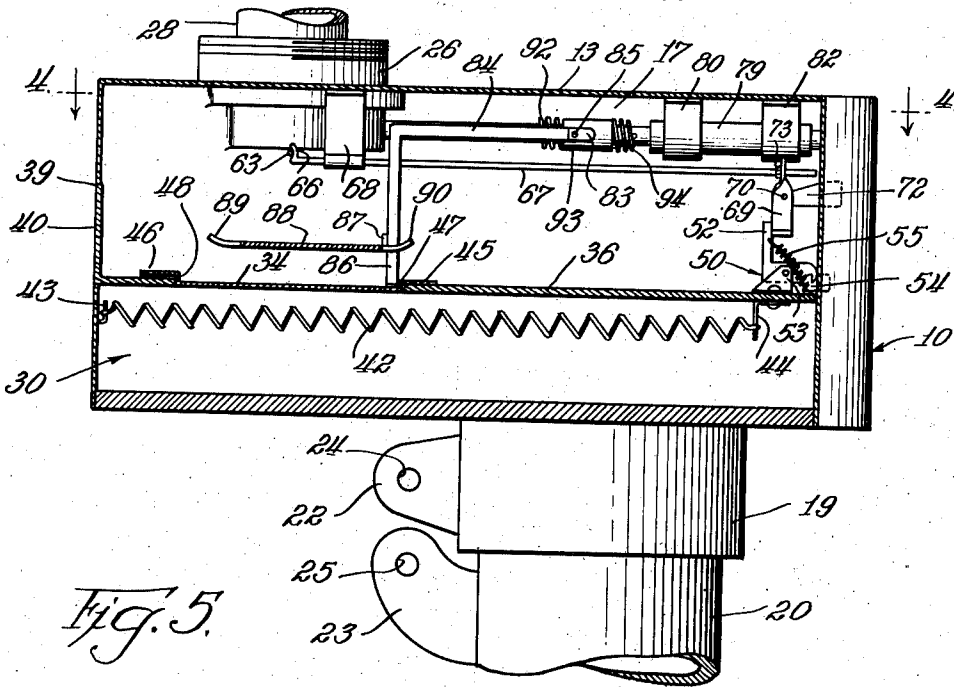
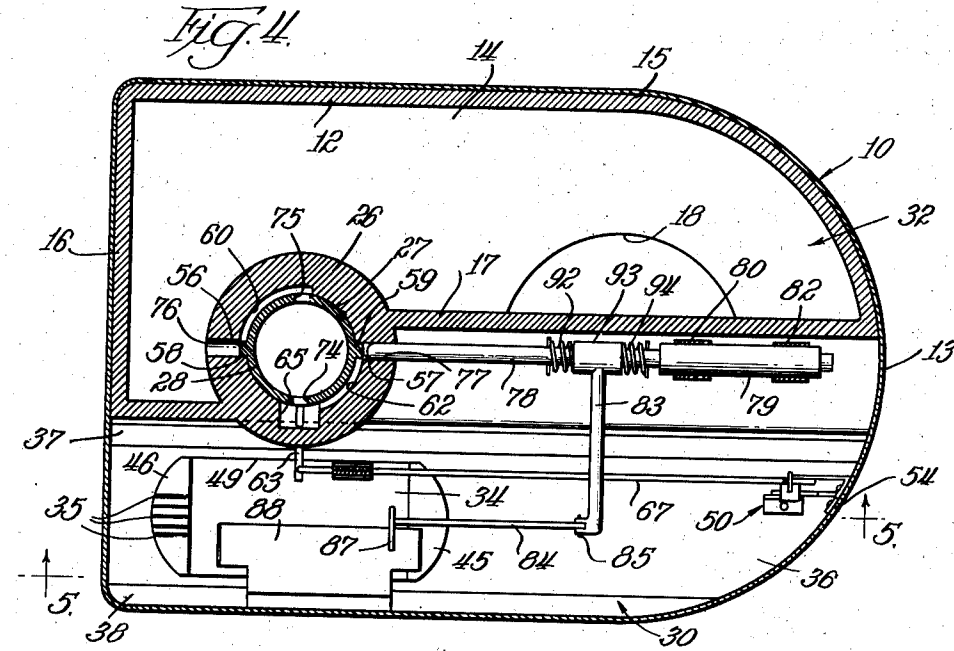

Fig. 5.

INVENTOR.
William A. Crews
BY
Albert E. McCall
att'y

UNITED STATES PATENT OFFICE

2,475,562

CLOSURE APPARATUS FOR TANKS AND THE LIKE

William A. Crews, River Forest, Ill.

Application February 6, 1947, Serial No. 726,873

10 Claims. (Cl. 226-65.5)

1

This invention relates to closure apparatus for tanks and the like, and more particularly to such apparatus adapted to use as a part of a system for the assurance and insurance of the delivery of full measure of some substance, such as a fluid, therethrough, the avoidance of undetectable thefts and the like.

The disclosed closure apparatus, although having a variety of adaptations and uses in itself and with other apparatus, is well suited to use with dispensing apparatus of the type shown in my copending application for United States Letters Patent, Serial No. 737,459, filed March 27, 1947.

Generally speaking, the closure apparatus for tanks and the like, disclosed herein, is adapted to function in conjunction with a connecting element, such as a nozzle, incorporating coacting interlocking means of a structure and arrangement such that said connecting element must be locked in place relative to the closure apparatus in order to effect the release of a key or control instrumentality necessary for producing flow through the connecting element. Furthermore, while the control instrumentality or key is thus released, the connecting element shall remain locked in place with respect to the closure apparatus. On the other hand, when the control instrumentality is replaced to an inaccessible position within the closure apparatus, the connecting element is released for removal.

From this brief statement relative to the structure and operation of my closure apparatus, it may be more readily understood that the invention comprehends the provision of such apparatus including control means adapted to a system for insuring delivery of full measure of a commodity, such as a liquid (gasoline, oil or the like) to a predetermined party, as well as for preventing partial and unauthorized deliveries.

It is another object of my invention to provide closure apparatus adapted to use on refillable supply tanks which are to be filled periodically or when desired by one or more authorized suppliers.

Another object of the invention is to provide closure apparatus for tanks and the like which is constructed and arranged to serve as a part of a system effecting supervision of each filling operation without the necessity of the actual presence of an observer to accomplish such supervision.

As another object, my invention comprehends the provision of closure apparatus for tanks and the like which embodies a lock mechanism for

2

retaining a connecting element in communication therewith during the transfer of a commodity, such as a liquid, therethrough.

My invention also has within its purview the provision of closure apparatus for tanks and the like which normally retains a control instrumentality in an enclosed and inaccessible position for release only upon the establishment of a flow connection to the apparatus, which flow connection may be broken only upon the replacement of the control instrumentality.

Other objects and advantages of the invention will be apparent from the following description and the accompanying drawings in which similar characters of reference indicate similar parts throughout the several views.

Referring to the drawings of which there are two sheets:

Figs. 1 and 2 are perspective views of a preferred form of my closure apparatus for tanks and the like which respectively indicate the apparatus in closed and open positions;

Fig. 3 is an end sectional view wherein the section is taken substantially on a line 3-3 of Fig. 2;

Fig. 4 is a top sectional view with the section taken substantially on a line 4-4 of Fig. 5; and

Fig. 5 is a side sectional view in which the section is taken substantially on a line 5-5 of Fig. 4.

In the exemplary embodiment of my invention which is shown in the accompanying drawings for illustrative purposes, my closure apparatus is depicted as a unitary structure having a housing 10, which housing desirably includes inner and outer shells 12 and 13 respectively. The inner shell provides a bottom wall 14, a side wall 15, an end wall 16, and a longitudinal partitioning wall 17. Desirably the bottom wall is provided with an outlet port 18 adjacent which and extending outwardly is an integrally formed collar 19 adapted to be secured to a conduit 20 or the like which connects to a refillable supply tank. Lugs 22 and 23 projecting from the outer surfaces of collar 19 and conduit 20 respectively and having openings 24 and 25 therethrough may be provided for locking or sealing the closure apparatus to the conduit so as to prevent its removal by an unauthorized person.

It is also by preference that a substantially ring-like collar 26 is integrally formed at the top and near one end of the longitudinal partitioning wall 17; said collar having a central aperture 27 therethrough on the same side of the partitioning wall 17 as the outlet port 18 to serve

3

as an inlet port and to receive a connecting element from a supply source such as a nozzle 28. The inner shell 12 is open to the flow of liquid and the like between the inlet and outlet ports, but is otherwise substantially closed.

The outer shell 13 fits over the inner shell 12 and is secured thereto and is so shaped that with a projecting side portion 29 of the bottom wall it forms a closed compartment extending longitudinally along the side of the partitioning wall 17 opposite the flow chamber 32 which is formed by the inner shell.

For sealing and closing the apparatus and the tank entrance between filling operations, a suitable cap 33 (Fig. 1) is fastened to the projecting upper end of the collar 26, as by being threaded thereon.

In a system of which the disclosed apparatus may comprise a part, it is proposed that the supply source from which a tank on which the disclosed apparatus is to be utilized shall be equipped with a keyed nozzle adapted to fit and coast with the disclosed apparatus to effect the release of an individualized control element such as a key 34 (Fig. 2). The key 34, as desired, or as the complicity of the system warrants, may or may not have data such as the name and address of an individual embossed thereon so as to serve as a printing die in a registering meter on the dispensing apparatus. Whether or not the key is individualized to the extent of having data embossed thereon for printing purposes, it is desirable that it shall be individualized to the extent of having some portion thereof keyed to fit the meter of the dispensing apparatus. In the disclosed apparatus and particularly as depicted in Fig. 2, one end portion of the key 34 is provided with notches or corrugations 35 which are adapted to effect the keying function.

The key 34, in one system of use, remains locked within the compartment 30 of the disclosed apparatus when that apparatus is not in use for filling the tank or container with which it is used. On the other hand, when the tank or container is to be filled, a keyed nozzle such as 28 is inserted into the filling aperture 27 and effects the release of the key 34. In effecting the release of the key, for the proposed system, the nozzle 28 is locked in place in the filling aperture 27 so that it cannot be removed therefrom until the key is replaced and restored to its normal position within the compartment 30 of the apparatus. With the key 34 thus released, it is free and adapted for use in effecting the release of flow through a dispensing nozzle from which the tank is to be filled. From this discussion it may be readily appreciated that by having the nozzle locked into the disclosed apparatus during the dispensing operation and by utilizing the key 34 to effect the release of flow through the dispensing nozzle, the user of the disclosed apparatus is assured of obtaining full measure since the nozzle cannot be removed during the dispensing operation and the dispensing apparatus cannot be utilized without the key.

Although various types and forms of mechanisms may be utilized for accomplishing the locking of the nozzle and the release of the key, I have disclosed herein one form of such mechanism which is suited to the purpose. A key-carrying slide 36 is supported for linear movement longitudinally of the compartment 30 by a pair of channel type tracks 37 and 38 disposed in opposed and substantially parallel relationship within the compartment 30 and extending in-

4

wardly from positions adjacent a front opening 39 in the outer shell 13. Both tracks are secured to and supported by the outer shell. At its outer end the slide 36 has an end portion 40 which fits and provides a closure for the opening 39 when the slide is in a retracted position inside the compartment. Resilient means such as a tension spring 42 having one end anchored to a lug 43 on the interior of the compartment and its other end anchored to a bracket 44 on the lower surface of the slide biases the slide to an extended position wherein it projects from the front of the housing, substantially as depicted in Fig. 2. The retracted or closed position of the slide is indicated in Figs. 1, 4 and 5.

In my disclosed structure the key 34 has flanged end portions 45 and 46 substantially parallel to and offset from the body portion of the key by integrally formed shoulder portions 47 and 48 respectively. With a key of the type and form disclosed it may be conveniently carried in a fixed position on the slide 36 by placement in an aperture 49 in that slide which fits the body portion of the key so that the flanged end portions 45 and 46 overlie and project above the upper surface of the slide. The position of the key-carrying aperture 49 is such that the key is entirely enclosed in an inaccessible position within the compartment 30 when the slide is in the retracted position and is exposed to provide access for the removal of the slide when it is in the extended position.

Normally the slide 36 is held in the retracted position against the biasing force of the spring 42 by a latch mechanism 50 which includes a pawl 52 carried for limited rotational movement by a bracket 53 secured to the upper surface of the slide near the inner end thereof. The pawl 52 has a notched end adapted to latching engagement with a stationary catch 54 secured to the inner surface of the outer shell in substantial alignment with the pawl longitudinally of the slide. By preference a spring 55 having one end connected to the pawl and its other end anchored to the slide is utilized to bias the pawl toward a latching position. Thus, when the slide is manually pushed into its retracted position, the pawl 52 is cammed over the end of the catch 54 and moves into latching engagement therewith to retain the slide in that retracted position until the pawl is disengaged from the catch.

In the disclosed embodiment of my invention, the disengagement of the pawl 52 from the catch 54 thereby to effect release of the slide 36, is accomplished by the insertion of a keyed nozzle such as 28 into the complementarily keyed aperture 27 of the collar 26. As an exemplary form of keying for the nozzle and collar, lugs 56 and 57 are formed on the outer surface of the nozzle and project outwardly therefrom at predetermined fixed positions. Complementary axial slots 58 and 59 are cut in the inner surface of the collar 26 so as to open into the aperture 27 at positions for receiving the lugs 56 and 57 respectively on the nozzle. At a predetermined depth below the top of the collar 26 the axial slots open into and are joined by oppositely disposed circumferential channels 60 and 62 so that when the nozzle is inserted to a predetermined depth into the aperture 27 of the collar, the lugs 56 and 57 act as stops for the axial movement and the nozzle may be turned with the lugs 56 and 57 moving along the circumferential channels 60 and 62. One of the channels, and in the present instance the channel 60, terminates at a

5

predetermined position for providing a stop for the circumferential movement of the nozzle.

As shown in Figs. 3 and 4, a crank type lever 63 is mounted for rotational movement in an axial bore 64 displaced to one side of the keyed aperture 27. One end of the lever 63 extends outwardly from the collar 26 and into the chamber 30 while the other end is disposed within a recess 65 adjoining the aperture 27 and open to the end of the channel 62. When the nozzle 28 is turned to a position such that the lug 56 engages the end of the channel 60, the lug 57 engages the end of the lever 63 to move it from its normal position shown in Fig. 4.

The outwardly extending end of the lever 63 engages a hooked end 66 of a linearly movable slide bar 67 which slide bar is supported for linear movement by a bracket 68 secured to the top of the outer shell 13 near the collar 26 and a fulcrumed lever 69 supported by a pin 70 from a bracket 72. Stop lugs 73 on the surface of the slide bar 67 engage the surface of the lever 69 so that movement of the slide bar toward that lever effects a resultant swinging movement of the lever. The end of the lever 69 opposite the slide bar 67 engages a projecting end of the pawl 52 whereby the actuated movement of the lever 69 moves the pawl 52 to disengage that pawl from the catch 54, releasing the slide for outward movement to the extended position. It may now be readily understood that the turning movement of the nozzle following its insertion into the keyed aperture 27 results in the release of the slide and its movement to the extended position in which the key 34 is available. It may also be readily understood that as long as the nozzle is in the position to which it is turned to effect such release of the slide, the lever 69 is held in position such that it will not permit the pawl to latch with the catch 54 so as to hold the slide in a retracted position. However, after slight movement of the nozzle toward a position for removal, the pawl may move to a slide retaining position.

Another function of the disclosed apparatus is to lock the nozzle 28 in place in the keyed aperture 27 of the collar 26 when the key is released for access and to maintain that locked relationship as long as the key has not returned to its predetermined normal position on the slide 36.

Although there are various ways in which the nozzle might be locked in place relative to the collar 26, in the present structure the nozzle is diametrically drilled to provide opposed bores 74 and 75 therein which align with diametrically opposed bores 76 and 77 respectively in the collar 26 when the nozzle is turned to its fully inserted and key-releasing position within the keyed aperture 27.

As shown in Fig. 4, a plunger rod 78 normally has one end disposed for linear movement in the bore 77 on one side of the collar 26 with its end retracted to a position such that it does not interfere with the insertion of the nozzle. The other end of the plunger rod is supported for linear movement by a tubular bearing 79 carried from the outer shell 13 by brackets such as 80 and 82. A collar near the mid-portion of the plunger rod 78 carries a laterally projecting rod 83 which at its outer end, has an angle-like actuating bar 84 movably connected thereto by means such as a pin 85. A depending end 86 of the actuating bar 84 is normally disposed in position for engagement with the shoulder 47 of the key 34 and engages that shoulder when the key is in place and the slide is in the retracted

6

position. Thus, as the slide moves outwardly, the shoulder 47 of the key moves with it the actuating bar 84 and the plunger rod 78, so that the plunger rod is moved to a position in which it extends through the aligned bores 74 and 75 in the nozzle and into the bores on both sides of the collar 26. This locks the nozzle in place so that it can neither be removed nor turned from its locked position.

The depending end 86 of the actuating bar 84 has secured thereto a laterally projecting strip 87 which normally rides along the upper surface of a cam plate 88 carried within the chamber 30 from an outer wall of the outer shell. The cam 88 thus controls the elevation of the depending end of the actuating bar 84. Along the mid-portion of the cam the elevation is maintained at a position such that the depending end of the actuating bar has firm engagement with the shoulder of the key but is normally above the upper surface of the slide. Hence, movements of the slide when the key is removed therefrom, do not actuate the actuating bar when that bar is in any position along the cam 88.

At its ends the cam 88 has portions 89 and 90 which slope upwardly away from the surface of the slide. Those upwardly sloping cam portions are of sufficient height that they move the actuating bar upwardly about the axis of the pin 85 to a height sufficient to clear the upper surface of the key. The cam portion 89 is disposed in a position such that it effects disengagement of the actuating bar from the shoulder 47 of the key after the plunger rod 78 has been moved to its locking position and before the key has completely emerged from the chamber 30 of the housing.

In order to assist the action of the end portion 89 of the cam in effecting release of the shoulder 47 of the key from the depending end of the actuating bar, a compression spring 92 is mounted on the plunger rod adjacent one end of an enlarged portion 93 on the rod, which spring is of a length such that it engages the outer surface of the collar 26 to move the plunger rod back a short distance when the depending end of the actuating bar is released from the shoulder 47 of the key. The plunger rod and its actuating bar remain in the locking position until the slide carrying the key 34 is manually moved toward its retracted position against the force of the spring 92. With the key in place, movement of the slide with the key therein from its fully extended position toward the retracted position effects engagement of the depending end of the actuating bar with the inner end surface of the key; it being recalled that the spring 92 has moved the plunger rod and its actuating bar back to a position in which the laterally projecting strip 87 on the actuating bar is off of the upwardly curved portion 89 of the cam.

When the depending end of the actuating bar is engaged by the end surface of the key, the inward movement of the slide retracts the plunger rod 78 to a position in which the nozzle is disengaged. Upon effecting such actuation of the plunger rod to a retracted position, a spring 94 on the plunger rod at the other end of the enlarged portion 93 of the rod engages the end of the bearing 79 at the time the cam portion 89 effects the release of the depending end of the actuating bar from the end surface of the key. Upon such release, the spring 94 moves the plunger rod and the actuating bar to a position in which the depending end of the actuating bar is again engaged by the shoulder 47 of the key. The

nozzle may then be removed, upon the commencement of which motion the latch mechanism 50 is freed to lock the slide in its retracted position.

From the foregoing description of the illustrated structure and its operation it may be readily understood that a properly keyed nozzle is required to effect the release of the slide and key although a tank or the like with which the apparatus is used may be filled from any nozzle which will fit into the keyed aperture 21. The introduction of a properly keyed nozzle into the keyed aperture of the collar 26 effects the release of the key-carrying slide 36, the outward movement of which slide automatically operates a locking mechanism to secure the nozzle in place. While the key 34 is removed from the slide, the slide may be manually moved back and forth between its retracted and extended positions but it is prevented from being locked in the retracted position and the slide along, without the key, has no effect upon the locking mechanism which holds the nozzle in place. When the key is removed from the slide, it may be used to effect the release of a dispensing valve or mechanism and may even be used to print the designated customer's name on the receipt when used in the dispensing mechanism. After being returned to its position in the slide, the key actuates the locking mechanism upon the return movement of the slide to the retracted position to release the locked nozzle, whereupon the slide may be locked in its retracted position. It is to be noted that the depending end of the plunger rod actuating bar 84 is moved to a position of re-engagement with the shoulder 47 of the key as soon as the plunger rod is retracted from the nozzle so that any subsequent outward movement of the slide will relock the nozzle.

While I have illustrated a preferred embodiment of my invention, many modifications may be made without departing from the spirit of the invention, and I do not wish to be limited to the precise details of construction set forth, but desire to avail myself of all changes within the scope of the appended claims.

Having thus described my invention, what I claim as new and desire to secure by Letters Patent of the United States, is:

1. Closure apparatus for tanks and the like adapted to use with a keyed nozzle and comprising, in combination, a housing having inlet and outlet ports therein, said housing being open to flow between the ports and having partitioning means therein providing a compartment segregated from the flow between the ports, and said housing having an opening therein at one end of the compartment, collar means secured to said housing at the intake port and providing a keyed aperture adapted to receive the keyed nozzle, means on the housing at the outlet port for locking the housing to a conduit, opposed tracks carried within said compartment in substantial alignment with said opening, a slide extending through said opening and carried by said tracks for linear movement between a retracted position in the housing and an extended position projecting from the exterior of the housing, said slide having means on the outer end thereof for closing said opening when the slide is in the retracted position and having a key-carrying aperture therein, a key carried in said aperture and having portions spaced longitudinally of the slide which project above the surface of the slide, resilient means for biasing the slide to the extended position, releasable latch means for hold-

ing the slide in the retracted position, means adapted to be actuated by movement of the keyed nozzle into place in the keyed aperture of said collar means for effecting release of said latch means, and means actuated by one of said portions of the key during movement of the slide to the extended position for locking the nozzle in place in the keyed aperture of said collar means.

2. Closure apparatus for tanks and the like adapted to use with a keyed nozzle and comprising, in combination, a housing having walls and provided with inlet and outlet ports, said housing being open to flow between the ports and having partitioning means therein providing a compartment segregated from the flow between the ports, and said housing having an opening in one of said walls opening into said compartment, collar means secured to said housing at the intake port and providing a keyed aperture adapted to receive the keyed nozzle, opposed tracks extending into said compartment from positions adjacent said opening, a slide extending through said opening and carried by said tracks for linear movement between a retracted position in the compartment and an extended position projecting from the housing, said slide having means on the outer end thereof for closing said opening when the slide is in the retracted position and having a key-carrying aperture therein, a key carried in said aperture and having a portion projecting from the surface of the slide, resilient means for biasing the slide to the extended position, releasable latch means for holding the slide in the retracted position, means adapted to be actuated by movement of the keyed nozzle into place in the keyed aperture of said collar means for effecting release of said latch means, means actuated by said projecting portion of the key during movement of the slide to the extended position for locking the nozzle in place in the keyed aperture of said collar means, and means for effecting release of the last mentioned means from said projecting portion of the key at a predetermined position in the outward movement of the slide.

3. Closure apparatus for tanks and the like adapted to use with a keyed nozzle and comprising, in combination, a housing having walls and provided with inlet and outlet ports, said housing being open to flow between the ports and having partitioning means therein providing a compartment segregated from the flow between the ports, and said housing having an opening in one of said walls opening into said compartment, collar means secured to said housing at the intake port and providing a keyed aperture adapted to receive the keyed nozzle, opposed tracks extending into said compartment from positions adjacent said opening, a slide extending through said opening and carried by said tracks for linear movement between a retracted position in the housing and an extended position projecting from the housing, said slide having means on the outer end thereof for closing said opening when the slide is in the retracted position and having a key-carrying aperture therein at a position such that it moves to the exterior of the housing when the slide moves to the extended position, a key carried in said aperture and having a portion projecting from the surface of the slide, resilient means for biasing the slide to the extended position, releasable latch means for holding the slide in the retracted position, means adapted to be actuated by movement of the keyed nozzle into place in the keyed aperture of said collar means for effecting release of said latch means, mova-

ble means actuated by said portion of the key during movement of the slide to the extended position for locking the nozzle in place in the keyed aperture of said collar means while the slide is in the extended position, means for effecting release of said movable means from said portion of the key at a predetermined position in the outward movement of the slide, and said movable means being actuated by said portion of the key during inward movement of the slide to the retracted position for effecting release of the nozzle lock.

4. Closure means for tanks and the like as defined in claim 3 wherein said latch means is retained in a position for effecting release of the slide until said nozzle lock is released.

5. Closure apparatus for tanks and the like adapted to use with a keyed nozzle and comprising, in combination, means having an inlet port, said means being open to flow through the inlet port and having an opening therein displaced from said port, collar means secured to said means at the intake port and providing a keyed aperture adapted to receive the keyed nozzle, movable means extending through said opening and movable between a retracted position within the first mentioned means and an extended position projecting from the exterior of the first mentioned means, said movable means having means thereon for closing said opening when the movable means is in the retracted position and having a key-carrying aperture therein at a position such that it is exposed when the movable means is in the extended position, a key carried in said aperture and having a portion projecting from the surface of the movable means, resilient means for biasing the movable means to the extended position, releasable latch means for holding the movable means in the retracted position, means adapted to be actuated by movement of the keyed nozzle into place in the keyed aperture of said collar means for effecting release of said latch means, and means actuated by said portion of the key during movement of the movable means to the extended position for locking the nozzle in place in the keyed aperture of said collar means.

6. Closure apparatus for tanks and the like adapted to use with a nozzle and comprising, in combination, means having an inlet port, said means being open to flow through the inlet port and having an opening therein displaced from said port, collar means at the intake port and providing an aperture adapted to receive the nozzle, movable means supported adjacent said opening for movements between a retracted position within the first mentioned means and an extended position projecting from the first mentioned means, said movable means having means thereon for closing said opening when the movable means is in the retracted position and having a key-carrying aperture therein at a position such that it is exposed when the movable means is in the extended position, a key carried in said aperture and having a portion projecting from the surface of the movable means, means for biasing the movable means to the extended position, releasable latch means for holding the movable means in the retracted position, means adapted to be actuated by movement of the nozzle into place in the aperture of said collar means for effecting release of said latch means, and means actuated by said portion of the key during movement of the movable means to the extended position for locking the nozzle in place in said aperture of the collar means.

7. In closure apparatus for tanks and the like adapted to use with a control instrumentality and a dispensing nozzle and comprising, in combination, means providing a nozzle-receiving port, a housing adjoining said means and having an opening therein displaced from said port, movable means supported adjacent said opening for movements between a retracted position substantially within the housing and an extended position projecting outwardly of said opening in the housing, said movable means providing a closure for said opening when in the retracted position and providing means for releasably carrying a control instrumentality at a fixed position such that it is enclosed when the movable means is in the retracted position and exposed when the movable means is in the extended position, means for biasing the movable means to one of said positions, releasable latch means for retaining the movable means in the other of said positions, a movable supported element having a portion extending into said housing and a portion in position for engagement by said nozzle, means interconnecting said element and said latch means to effect release of the latch means when the nozzle is seated in said port, and means having a portion in position for actuation by said control instrumentality during movement of the movable means from one position to the other, the last mentioned means including a nozzle-locking part for locking the nozzle in the port when the movable means is in one of said positions.

8. In closure apparatus for tanks and the like adapted to use with a control instrumentality and a dispensing nozzle and comprising, in combination, means providing a nozzle-receiving port, a housing adjoining said means and having an opening therein displaced from said port, movable means supported adjacent said opening for movements between a retracted position substantially within the housing and an extended position projecting outwardly of said opening in the housing, said movable means providing a closure for said opening when in the retracted position and providing means for releasably carrying a control instrumentality at a fixed position such that it is enclosed when the movable means is in the retracted position and exposed when the movable means is in the extended position, means for biasing the movable means to one of said positions, releasable latch means for retaining the movable means in the other of said positions, a movably supported element having a portion extending into said housing and a portion in position for engagement by said nozzle, and means interconnecting said element and said latch means to effect release of the latch means when the nozzle is seated in said port.

9. In closure apparatus for tanks and the like and adapted to use with a keyed connecting element and as a part of a system utilizing an individualized control instrumentality, the combination comprising, means providing a flow connection for a connecting element, a housing adjoining said means for normally retaining the control instrumentality and having an opening therein through which the control instrumentality is accessible, movable means for closing said opening, locking means for holding the movable means in a closing position relative to said opening, and a movable element supported relative to the first mentioned means in position for actuation by the keyed connecting element for controlling said locking means.

10. In closure apparatus for tanks and the like

11

and adapted to use with a keyed connecting element and as a part of a system utilizing an individualized control instrumentality, the combination comprising, means providing a flow connection for a connecting element, a housing adjoining said means for normally retaining the control instrumentality and having an opening therein through which the control instrumentality is accessible, movable means for closing said opening, locking means for holding the movable means in a closing position relative to said opening, and a movable element actuated by said movable means and including a locking element for holding the

12

connecting element in place relative to the first mentioned means.

WILLIAM A. CREWS.

REFERENCES CITED

The following references are of record in the file of this patent:

UNITED STATES PATENTS

Number	Name	Date
535,880	Anderson	Mar. 19, 1895
641,846	Davenport et al.	Jan. 23, 1900