

A. S. Newhouse,

Bedstead Fastening,

N^o. 9,034.

Patented June 15, 1852.

Fig. 2.

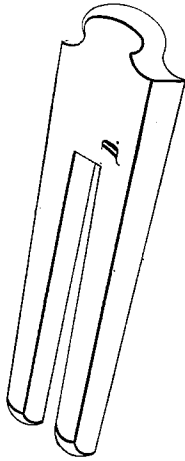

Fig. 3.

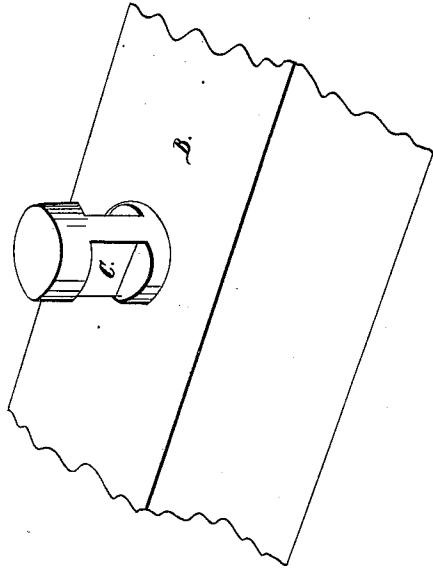
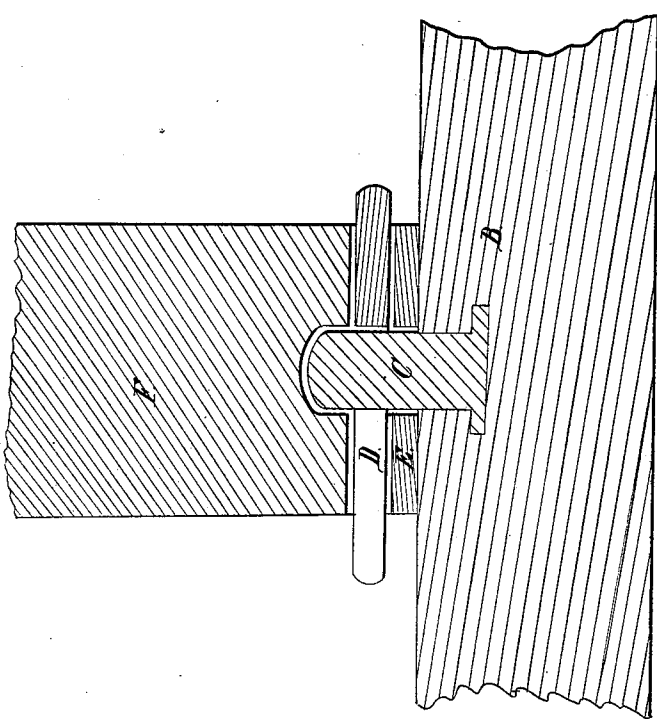

Fig. 1.



UNITED STATES PATENT OFFICE.

A. S. NEWHOUSE, OF McBEEN, GEORGIA.

BEDSTEAD-FASTENING.

Specification of Letters Patent No. 9,034, dated June 15, 1852.

To all whom it may concern:

Be it known that I, ADAM S. NEWHOUSE, of the county of Richmond and State of Georgia, have invented a new and Improved Joint for Bedsteads and all other Articles where a Movable Joint is Required; and I do hereby declare that the following is a full and exact description thereof, reference being had to the accompanying drawings and letters marked thereon.

Figure 1, a central section through post, rail pin and key; Fig. 3, post B, pin C; Fig. 2, key D.

To enable others skilled in the art to make and use my invention I will proceed to describe its construction and operation.

The mode of fastening consists in insert-

ing the key D described in Fig. 2, in the groove in the end of the rail between plate E, Fig. 1, and the end of the rail and passing in a groove on each side of pin C as marked in Fig. 3 which when together produces great strength of joint, besides taking far less time in the arrangement than the ordinary kinds or modes of fastening.

What I claim as my invention and desire to secure by Letters Patent is—

Securing the rail to the post by means of pin C, key D and plate E in the manner substantially herein set forth.

A. S. NEWHOUSE.

Witnesses:

B. CORNELL,
C. C. BEVERIDGE.