



(11) **EP 3 498 622 A1**

(12) **EUROPEAN PATENT APPLICATION**

(43) Date of publication:
19.06.2019 Bulletin 2019/25

(51) Int Cl.:
B65D 5/74 (2006.01) **B65D 8/00 (2006.01)**
B65D 3/08 (2006.01)

(21) Application number: **18213550.9**

(22) Date of filing: **18.12.2018**

(84) Designated Contracting States:
AL AT BE BG CH CY CZ DE DK EE ES FI FR GB GR HR HU IE IS IT LI LT LU LV MC MK MT NL NO PL PT RO RS SE SI SK SM TR
Designated Extension States:
BA ME
Designated Validation States:
KH MA MD TN

(72) Inventors:
• **JACOBSSON, Kristian**
247 51 Dalby (SE)
• **KELLER, Oliver**
22307 Hamburg (DE)
• **STAWENOW, Paul**
20535 Hamburg (DE)
• **FRERICHS, Johanna**
20257 Hamburg (DE)

(30) Priority: **18.12.2017 EP 17208132**

(71) Applicant: **Tetra Laval Holdings & Finance S.A.**
1009 Pully (CH)

(74) Representative: **Tetra Pak - Patent Attorneys SE**
AB Tetra Pak
Patent Department
Ruben Rausings gata
221 86 Lund (SE)

(54) **PACKAGE AND BLANK FOR MANUFACTURING THE PACKAGE**

(57) A package (1) for storing a liquid food product is provided. The package (1) comprises a base part (2) manufactured from a blank (8) of packaging material, a top part (3), wherein the base part (2) and the top part (3) are joined together to form the package (1). The base part (2) comprises an essentially rectangular or square shaped bottom (7) and four side walls (5a, 5b, 6a, 6b) extending from the bottom (7) towards the top part (3). A first side wall (5a) and an opposite second side wall (5b) each have a cross-section taken in a plane orthogonal to the bottom (7) that transitions, from the bottom (7) towards the top part (3), from an essentially planar shape to an essentially concave shape.

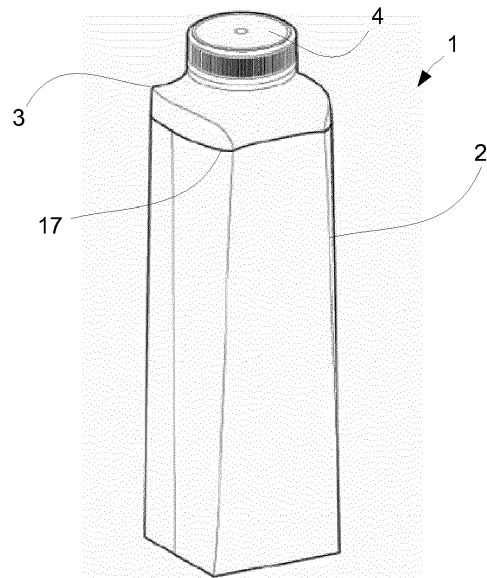

Fig. 1

Description

Technical Field

[0001] The present solution relates to packages, and to blanks for manufacturing packages or parts of packages. More specifically, the present solution relates to a package, preferably for containing pourable liquid food products, for improving its ergonomic properties and its maneuverability.

Background Art

[0002] Today there is a wide selection of packages for pourable products, such as liquid food products, available on the market. To increase the sustainability of the packaging industry, many companies move away from using all plastic packages to using more environmentally friendly materials such as paper, or carton-based material, for at least parts of the packages. This is currently an increasing trend as packages which are made from carton-based blanks today are used for a wide range of liquid food products, also for products previously only found distributed in plastic bottles.

[0003] As the market for packages manufactured from carton-based blanks increases, so does the desire to improve the packages. An inherent problem when manufacturing packages from carton-based blanks is that it is more difficult to differentiate packages/products from each other. A further problem is that packaging products made from carton-based blanks often lack the ergonomic properties of their entirely plastic counterparts as they are more complex to form.

Summary

[0004] It is an object of the invention to at least partly overcome one or more of the above-identified limitations of the prior art. In particular, it is an object to provide a package which has improved ergonomic properties, and differentiates itself from prior art packages. It is also an object of the invention to provide a blank for manufacturing such a package.

[0005] To achieve these objects a package for storing a liquid food product is provided. The package comprises a base part manufactured from a blank of packaging material and a top part. The base part and the top part are joined together to form the package. The base part comprises an essentially rectangular or square shaped bottom and four side walls extend from the bottom towards the top part. A first wall and an opposite second side wall each have a cross-section taken in a plane perpendicular to the bottom that transitions, from the bottom towards the top part, from an essentially planar shape to an essentially concave shape. Moreover, the horizontal distance between the first crease line and second crease line along the third panel increases from a bottom crease towards a top edge wherein the horizontal distance be-

tween the third crease line and fourth crease line along the fourth panel increases from the bottom crease line towards the top edge.

[0006] The package is advantageous as it provides improved ergonomic properties for example in the concave and the convex walls which provides natural and more comfortable grip zones. The package is thus made easier to use, and furthermore the shape of the package differentiates it from other packages.

[0007] To further improve the ergonomics, a third side wall and an opposite fourth side wall each have a cross-section taken in a plane being parallel with the bottom that transitions, from the bottom towards the top part, from an essentially planar shape to an essentially convex shape.

[0008] The shape of the top part may preferably conform to the shape of the four side walls.

[0009] The base part may be formed by a packaging material comprising one or more layers of material one of which may be a carton-based material, which provides a package that is environmentally friendly, inexpensive whilst still providing safe protection of the food product contained in the package.

[0010] The top part may be formed by a plastic material, preferably by injection moulding of a thermoplastic material simultaneously while joining the top part to the base part.

[0011] The blank may comprise a first and a second crease line defining a third panel forming the third wall of the package, and a third crease line and fourth crease line defining a fourth panel forming the fourth wall of the package. The second crease line and third crease line define a first panel forming the first wall of the package, and the first crease and fourth crease define a second panel forming the second wall of the package. Each crease line may correspond to a corresponding fold in the package.

[0012] The horizontal distance between the second crease line and third crease line along the first panel may decrease from the bottom crease line toward a top edge, and the horizontal distance between the first crease line and fourth crease line along the second panel may decrease from a bottom crease line towards a top edge.

[0013] The top part may comprise a first top part wall and an opposite second top part wall, the first and second top part walls having a convex shape that corresponds to the convex shape of the third and fourth walls of the base part respectively. The top part may further comprise a third top part wall arranged between the first and second top part walls and the third top part wall comprises an opening. The third top part wall conforms to the concave shape of the first and second wall of the base part. The convex and the concave shape of the base part thus extends to the top part where it transitions into an opening, the top part providing further structural rigidity to the base part and thus to the entire package.

[0014] The top part may further comprise first and second curved edges which separates the first and second

top part walls from the third top part wall. The first edge connecting essentially tangentially to the first and second crease line and the second edge connects essentially tangentially to the third and fourth crease lines.

[0015] The top part and the base part may be configured to be joined together in a joint comprising a weakening such that the top part may be removed from the base part. The removing of the top part from the base part is beneficial for recycling purposes and could also allow the user for to easier extract all the food stuff which may be difficult to extract from the opening.

[0016] A blank for manufacturing a base part of a package is further provided. The blank is essentially rectangular in shape comprising a plurality of crease lines.

[0017] The blank may comprise a bottom crease line defining transitions between the bottom and the side walls and the first, second, third and fourth crease lines stretches from the bottom crease line to a top edge. The first and second crease lines are straight crease lines being closer together toward the bottom crease line and further apart toward a top edge of the blank. The third and fourth crease lines are straight crease lines being closer together toward the bottom crease line and further apart toward the top edge of the blank. The provision of straight crease lines which then forms the complex shapes which are the transitions between the side walls of the base part simplifies the manufacturing process of the base part.

[0018] The second panel of the blank may comprise a first part and a second part being arranged on opposite sides of the blank and the two parts being configured to be joined together to form the second wall.

[0019] The blank may comprise a fifth and a sixth crease line and the fifth crease line is arranged between the first and second crease lines, the sixth crease line is arranged between the third and fourth crease lines. The fifth and sixth crease lines are straight with extension essentially perpendicularly from the bottom crease line to the top edge.

[0020] Still other objectives, features, aspects and advantages of the invention will appear from the following detailed description as well as from the drawings.

Brief Description of the Drawings

[0021] Embodiments of the invention will now be described, by way of example, with reference to the accompanying schematic drawings, in which

Fig. 1 is an isometric view of a package according to one embodiment,

Fig. 2 is an isometric view of a base part of a package according to one embodiment,

Fig. 3 is bottom view of a base part of a package according to one embodiment,

Fig. 4 is an isometric view of a top part according to one embodiment,

Fig. 5 is a front view of a blank according to one

embodiment, and

Fig. 6 is a front view of a blank according to another embodiment.

5 Detailed description

[0022] The disclosed embodiments will now be described more fully hereinafter with reference to the accompanying drawings, in which certain embodiments of the invention are shown. Like numbers refer to like elements throughout. With reference to Fig. 1 a package 1 is shown. The package 1 comprises a base part 2 and a top part 3 which are joined together to form the package 1. A fluid-tight joint 17 is formed at the transition between the top part 3 and the base part 2. A closure 4 in the top part 3 is shown, here in the shape of a cap which can be screwed on and off. However, other closures 4 are also feasible such as for instance peel-back lids, or tear-off membranes.

[0023] The base part 2 is preferably made from a carton-based packaging material in the form of a blank 8. The carton-based packaging material may be a laminate material comprising several polymeric layers on both sides of a carton-based core layer. The carton-based material could be paper, paper board, carton or other similar fiber-based materials.

[0024] The carton-based material is preferably the core material of the packaging laminate material and having a surface coating of thermoplastics on at least one of its two surfaces. Such a surface coating could be polyethylene film (PE film), but other materials could also be used in combination, such as for instance aluminum foil coated by a PE film on both sides, i.e. towards the interior of the package and away from the interior of the package.. The packaging material may be cut to form sheets comprising individual blanks 8 which are then folded and joined together along a longitudinal seal to form the base part 2.

[0025] The top part 3 is preferably of HDPE, high density polyethylene, however other thermoplastic polymer materials are of course also conceivable.

[0026] The joint 17 between the top part 3 and the base part 2 could optionally be designed with a weakening along the joint 17, such as a perforation, to facilitate separation of the top part 3 and the base part 2 for instance for recycling purposes or for allowing a user to reach enclosed food product which is otherwise hard to extract through the opening 4.

[0027] As can be seen in Fig. 1, the base part 2 contains the major amount of food inside the package 1; the top part 3 provides the closure 4 and also stability and structural rigidity to the base part 2. The top part 3 may for example be manufactured by injection moulding, whereby the material for the top part 3 is injected into a mold, comprising an inner mould and an outer mould. The outer mould may have a conical shape over which the base part is pulled, while the inner mould may surround the outer mould and correspond in shape to the top part 3.

At least the top edge 16 of the base part 2 is partially located on the cone forming the outer mould, such that after injection moulding the material in the top part 3 forms a bond in the joint 17 with material of the base part 2. When the material in the top part 3 hardens it will also, as mentioned, contribute to maintaining the shape of the walls 5a, 5b, 6a, 6b of the base part 2.

[0028] In the following the base part 2 will be described in further detail with reference to Figs. 2, 3, 5 and 6. The base part 2 comprises a bottom 7, which is formed by means of folding along a plurality of crease lines in a conventional manner which is to be considered well known in the art and will thus not be explained in further detail. The bottom 7 may be rectangular in shape, while more specifically a square shape is envisioned in one embodiment. Other shapes are however also feasible, such as more oblong rectangular shapes or D-shaped bottoms.

[0029] The base part 2, as shown in Fig. 2, comprises four side walls 5a, 5b, 6a, 6b which extend from the bottom 7 to the top edge 16 of the base part 2. The top edge 16 is the part of the base part 2 which is configured to be joined to the top part 3 by injection moulding or some other process.

[0030] A first side wall 5a and a second side wall 5b are arranged on opposite sides of the base part 2 and are both configured such that they transition from the bottom 7 to the top edge 16 from an essentially planar shape close to the bottom 7 to an increasingly concave shape towards the top edge 16. The concave shape is defined as seen in a cross-sectional plane through the side walls 5a, 5b, and where the cross-sectional plane is orthogonal the bottom 7.

[0031] The third and fourth side walls 6a, 6b are also arranged on opposite sides of the base part 2 and are both configured such that they transition from the bottom 7 to the top edge 16 from an essentially planar shape close to the bottom 7 to an increasingly convex shape towards the top edge 16. The convex shape is defined as seen in cross-sectional plane orthogonal to the bottom 7 through the side walls 6a, 6b.

[0032] The concave shape of the first and second walls 5a, 5b in combination with the convex shape of the third and fourth walls 6a, 6b provides a package 1 with improved ergonomics. The convex walls 6a, 6b are configured for fitting comfortably against the palm of a consumer while the concave walls 5a, 5b are configured such that they form gripping zones for the fingers of the user. Also, by the provision of the concave and the convex walls 5a, 5b, 6a, 6b, a consumer will be able to see for instance product names or logos on the package from further distances and/or more shallow angles.

[0033] The base part 2 is formed from a blank 8, as is shown in Fig. 5. The blank 8 comprises crease lines 9-15 which may be formed into corresponding folds or edges in the base part 2 when raising the base part 2 of the package 1. A first and a second crease line 9, 11 define a third panel 6'a corresponding to the third wall 6a of the

folded base part 2. A third and fourth crease line 12, 14 define a fourth panel 6'b corresponding to the fourth wall 6b of the folded base part 2. That is, the third panel 6'a extends from the bottom 7 to the top edge 16 between the first and second crease lines 9, 11. This is analogous for all the panels 5'a, 5'b, 6'a, 6'b of the blank 8.

[0034] The horizontal distance between the first and second crease lines 9, 11 along the third panel 6'a increases from a bottom crease line 15 towards the top edge 16. That is, a horizontal line across the convex surface of the third wall 6a from the first crease line 9 to the second crease line 11 will become progressively longer from the bottom 7 approaching the top edge of the base part 2.

[0035] The horizontal distance between the third and fourth crease lines 12, 14 along the fourth panel 6'b also increases from the bottom crease line 15 and towards the top edge 16, preferably such that the width between the respective crease lines 9, 11, 12, 14 measured along the surface of the third and fourth wall 6a, 6b on a certain height above the bottom 7 is essentially the same.

[0036] The first panel 5'a, corresponding to the first wall 5a of the base part 2, is defined by the second and third crease lines 11, 12. The first and fourth crease lines 9, 14 define the second panel 5'b, corresponding to the second wall 5b of the base part 2.

[0037] However, for the concave walls 5a, and 5b, the horizontal distance between the second and third crease lines 11, 12 along the first wall 5a decreases from a bottom crease line 15 towards the top edge 16 as does the horizontal distance between the first and fourth crease lines 9, 14 along the second wall 5b from the bottom crease line 15 towards the top edge 16. As for the convex third and fourth walls 6a, 6b, the width between the respective crease lines defining each wall measured along the surface of each concave wall 5a, 5b is essentially the same for a given height above the bottom 7.

[0038] In Figs. 5 and 6 are two embodiments of a blank 8 shown. A blank 8 is a well-known item to the skilled person, and should be construed as a piece of packaging material configured to be folded into packages or parts of packages such as base parts 2.

[0039] The blank 8 comprises crease lines 9-15, which facilitate and serve as templates for the folding the blank 8 into a base part 2. The blank 8 is preferably of a rectangular shape. It is to be understood that while only single blanks 8 are shown, blanks 8 can be provided as a web of continuous packaging material, whereby consecutive blanks are arranged side by side or in any other orientation on the web.

[0040] The blank 8 comprises a bottom crease line 15 defining transitions between the bottom 7 and the side walls 5a, 5b, 6a, 6b. As can be seen in Figs. 5 and 6, a plurality of crease lines are shown below the bottom crease 15. These are present to facilitate the folding of the bottom 7 of the base part 2, and as mentioned above, are considered to be known by a skilled person and will thus not be explained in further detail.

[0041] The first, second, third and fourth crease lines 9, 11, 12, 14 stretches in an essentially straight line from the bottom crease line 15 to a top edge 16 of the blank 8. The first and second crease lines 9, 11, and the third and fourth crease lines 12, 14 respectively, are arranged such that they are closer together toward the bottom crease line 15 and further apart toward a top edge 16 of the blank 8. Thus, the third wall 6a which extends between the first and second crease lines 9, 11 and the fourth wall 6b which extends between the third and fourth crease lines 12, 14 both taper towards the bottom crease line 15. The opposite relationship is found for the first and second walls 5a, 5b which extend between the second and third crease lines 11, 12 and between the first and fourth crease lines 9, 14 respectively, which tapers from the bottom crease line 15 towards the top edge 16.

[0042] As is shown in Figs 5. and 6, the second panel 5'b may be divided into a first part 5b1 and a second part 5b2 on separate sides of the blank 8 and being configured to be joined together to form the second wall 5b. It should be realized that each of the walls 5a, 5b, 6a, 6b could be divided into two parts in a similar manner.

[0043] As can be seen in Fig. 6, the blank 8 may comprise a fifth and a sixth crease line 10, 13. The fifth crease line 10 is preferably arranged at the center between the first and second crease lines 9, 11 and the sixth crease line 13 is preferably arranged at the center between the third and fourth crease lines 12, 14. The fifth and sixth crease lines 10, 13 are straight crease lines with extension essentially orthogonally from the bottom crease line 15 to the top edge 16. The fifth and sixth crease lines 10, 13 thus divide the third wall 6a and the fourth wall 6b longitudinally in two approximately equally sized parts.

[0044] Now turning to Fig. 4, the top part 3 of the package 1 will be described in closer detail. As can be seen, the top part 3 may comprise top part walls 3a, 3b, 3c which conform to the shape of the base part 2. The first and second opposite top part walls 3a, 3b thus have convex shapes that essentially correspond to the convex shape of the third and fourth walls 6a, 6b of the base part 2 by visually forming one continuous surface. The third top part wall 3c is arranged between the first and second top part walls 3a, 3b and comprises the closure 4 in the form of a cap 4 mounted onto a neck of the top part forming the opening of the top part. The third top part wall 3c conforms or transitions gradually towards the joint 17 to the concave shape of the first and second wall 5a, 5b of the base part 2, thus also visually forming one continuous surface. The top part 3 may further comprise first and second curved edges 3d, 3e which separate the first and second top part walls 3a, 3b from the third top part wall 3c. The first edge 3d connects essentially tangentially to the first and second crease line 9, 11 and the second edge 3e connects essentially tangentially to the third and fourth crease line 12, 14. The first and second edges 3d, 3e thus provide a shoulder like shape to the package 1 and more specifically the top part 3.

[0045] From the description above follows that, al-

though various embodiments of the invention have been described and shown, the invention is not restricted thereto, but may also be embodied in other ways within the scope of the subject-matter defined in the following claims.

Claims

1. A package (1) for storing a liquid food product, the package (1) comprising
 - a base part (2) manufactured from a blank (8) of packaging material,
 - a top part (3), wherein the base part (2) and the top part (3) are joined together to form the package (1),
 - wherein the base part (2) comprises an essentially rectangular or square shaped bottom (7) and
 - four side walls (5a, 5b, 6a, 6b) extending from the bottom (7) towards the top part (3),
 - wherein a first side wall (5a) and an opposite second side wall (5b) each have a cross-section taken in a plane orthogonal to the bottom (7) that transitions, from the bottom (7) towards the top part (3), from an essentially planar shape to an essentially concave shape,
 - characterized in that** the horizontal distance between the first crease line (9) and second crease line (11) along the third panel (6'a) increases from a bottom crease (15) towards a top edge (16), and wherein the horizontal distance between the third crease line (12) and fourth crease line (14) along the fourth panel (6'b) increases from the bottom crease line (15) towards the top edge (16).
2. The package (1) according to claim 1, wherein a third side wall (6a) and an opposite fourth side wall (6b) each have a cross-section taken in a plane orthogonal to the bottom (7) that transitions, from the bottom (7) towards the top part (3), from an essentially planar shape to an essentially convex shape.
3. The package (1) according to claim 1 or 2, wherein the shape of the top part (3) conforms to the shape of the four side walls (5a, 5b, 6a, 6b), such that the top part (3) and the parts of the four side walls (5a, 5b, 6a, 6b) near the top part visually form one continuous surface.
4. The package (1) according to any one of the preceding claims, wherein the base part (2) is formed by a carton-based packaging material.
5. The package (1) according to any one of the preceding claims, wherein the top part (3) is formed by a

- plastic material, preferably by injection moulding of a thermoplastic material simultaneously while joining the top part (3) to the base part (2).
6. The package (1) according to any one of the preceding claims, wherein the blank (8) comprises a first crease line (9) and a second crease line (11) defining a third panel (6'a) forming the third wall (6a) of the package (1), and a third crease line (12) and fourth crease line (14) defining a fourth panel (6'b) forming the fourth wall (6b) of the package (1), wherein the second crease line (11) and third crease line (12) define a first panel (5'a) forming the first wall (5a) of the package (1), and the first crease line (9) and fourth crease line (14) define a second panel (5'b) forming the second wall (5b) of the package (1).
 7. The package (1) according to claim 5 or 6, wherein the horizontal distance between the second crease line (11) and third crease (12) along the first panel (5'a) decreases from a bottom crease line (15) towards a top edge (16), and wherein the horizontal distance between the first crease line (9) and fourth crease line (14) along the second panel (5'b) decreases from the bottom crease line (15) towards the top edge (16).
 8. The package (1) according to any one of claims 6 to 8, wherein the top part (3) comprises a first top part wall (3a) and a opposite second top part wall (3b), said first and second top part walls (3a, 3b) having a convex shape that corresponds to the convex shape of the third wall (6a) and the fourth wall (6b) of the base part (2) respectively, and wherein the top part (3) further comprises a third top part wall (3c) arranged between the first top part wall (3a) and the second top part wall (3b), wherein the third top part wall (3c) comprises an opening (4), and wherein the third top part wall (3c) conforms to the concave shape of the first wall (5a) and the second wall (5b) of the base part (2).
 9. The package (1) according to claim 9, wherein the top part (3) further comprises a first curved edge (3d) and a second curved edge (3e) separating the first top part wall (3a) and the second top part wall (3b) from the third top part wall (3c), said first edge (3d) connecting essentially tangentially to the first and second crease lines (9, 11) and said second edge (3e) connecting essentially tangentially to the third and fourth crease lines (12, 14).
 10. The package (1) according to claim 9 or 10, wherein the top part (3) and the base part (2) are configured to be joined together in a joint (17) comprising a weakening such that the top part (3) may be removed from the base part (2).
 11. A blank (8) of packaging material for manufacturing a base part (2) of a package (1) according to any one of the preceding claims, wherein the blank (8) is essentially rectangular comprising a plurality of crease lines (9, 10, 11, 12, 13, 14, 15).
 12. The blank (8) according to claim 11, further comprising a bottom crease line (15) defining transitions between the bottom (7) and the side walls (5a, 5b, 6a, 6b), wherein the first, second, third and fourth crease lines (9, 11, 12, 14) extend from the bottom crease (15) to a top edge (16), the first and second crease lines (9, 11) being straight crease lines being closer together toward the bottom crease line (15) and further apart toward a top edge (16) of the blank (8), and wherein the third and fourth crease lines (12, 14) are straight crease lines being closer together toward the bottom crease line (15) and further apart toward the top edge (16) of the blank (8).
 13. The blank (8) according to claim 11 or 12, wherein the second panel (5'b) comprises a first part (5b1) and a second part (5b2) being arranged on opposite sides of the blank (8), the two parts (5b1, 5b2) being configured to be joined together to form the second wall (5b).
 14. The blank (8) according to claim 12 or 13, further comprising a fifth crease line (10) and a sixth crease line (13), and wherein the fifth crease line (10) is arranged between the first and second crease lines (9, 11) and wherein the sixth crease line (13) is arranged between the third and fourth crease lines (12, 14), the fifth and sixth crease lines (10, 13) being straight crease lines extending essentially perpendicularly from the bottom crease (15) to the top edge (16).

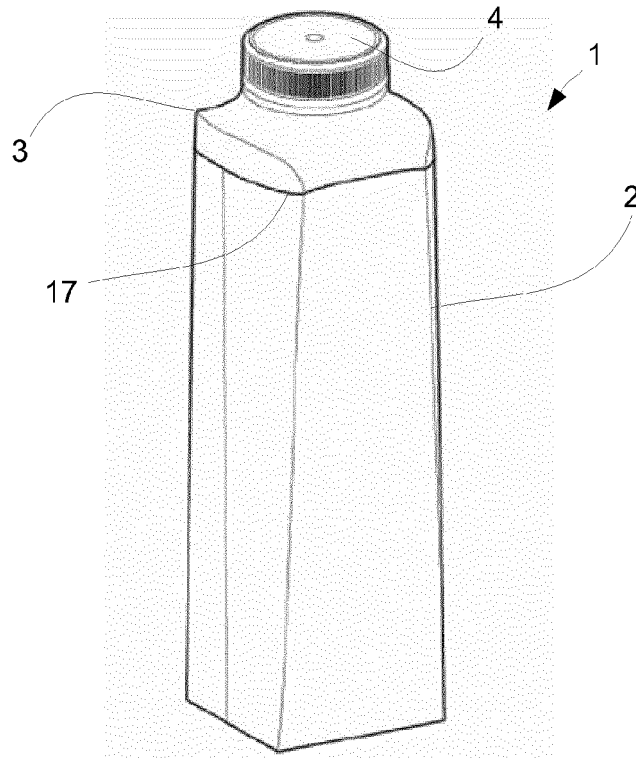

Fig. 1

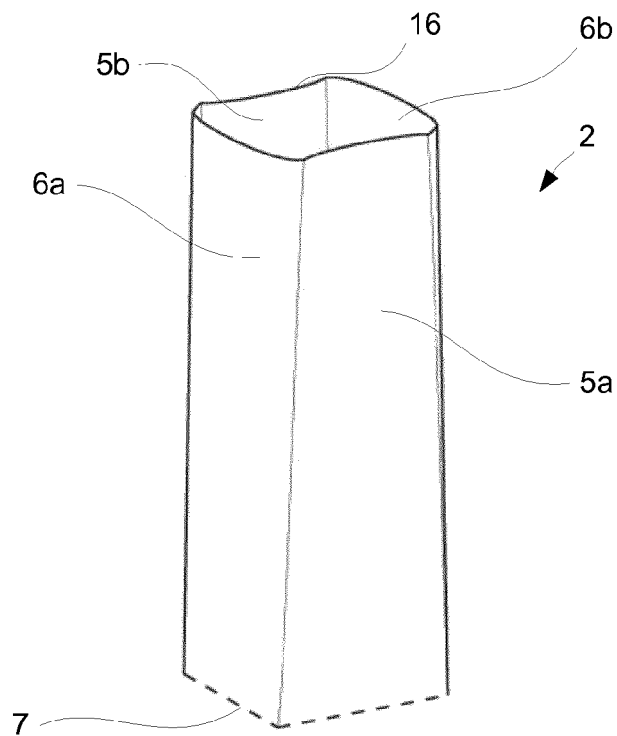

Fig. 2

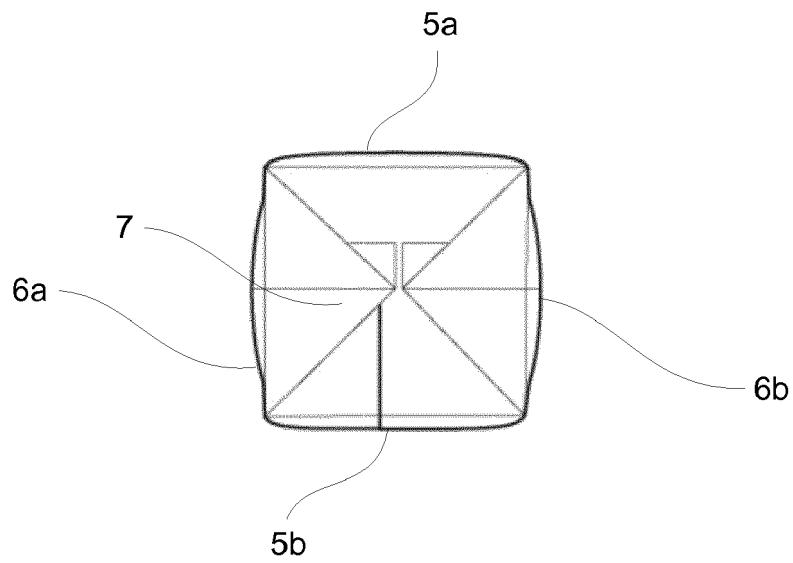

Fig. 3

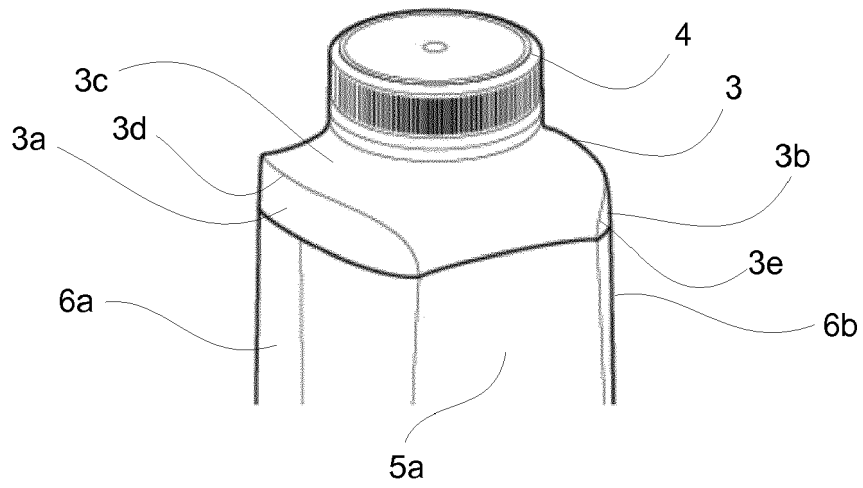

Fig. 4

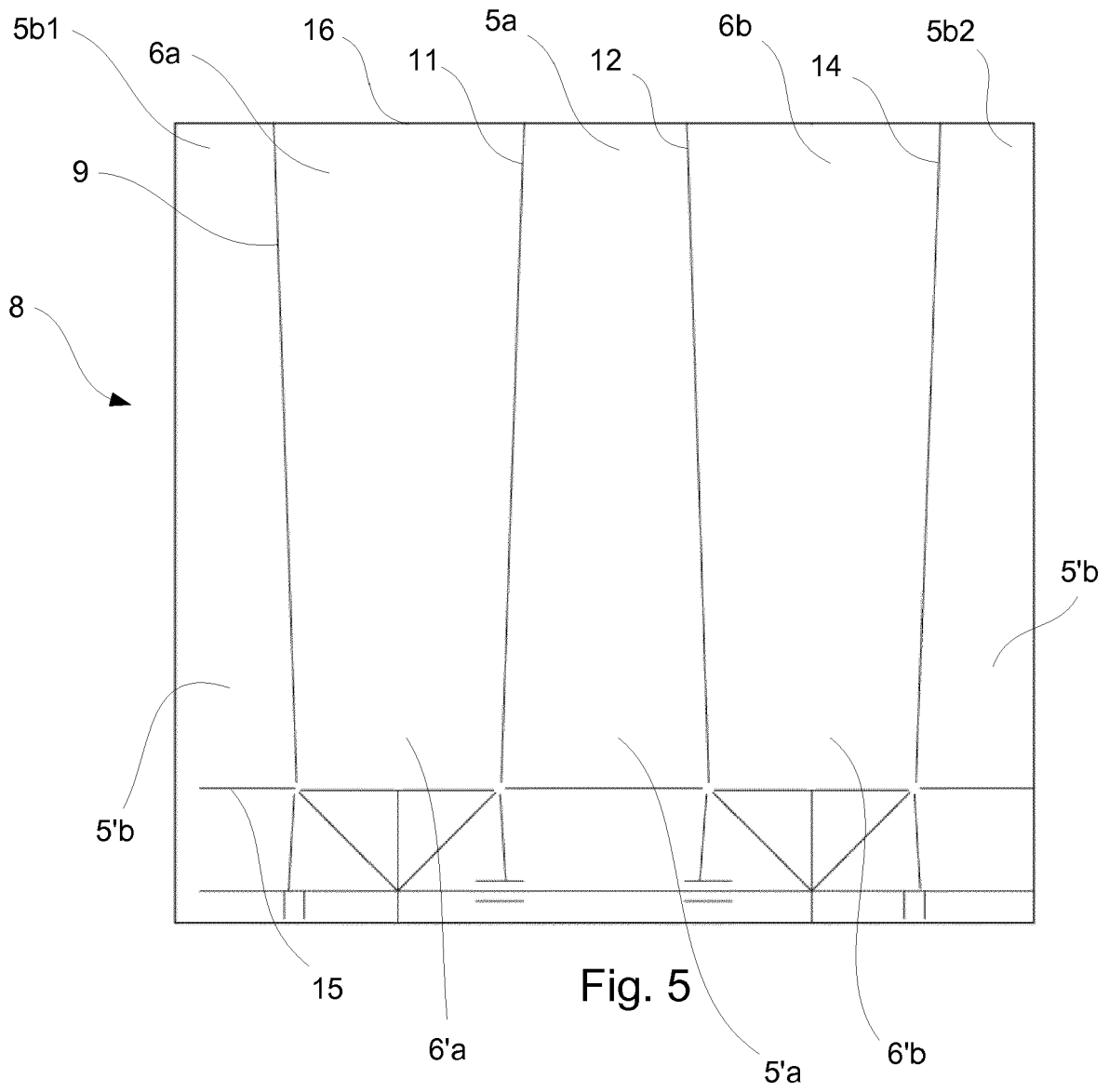

Fig. 5

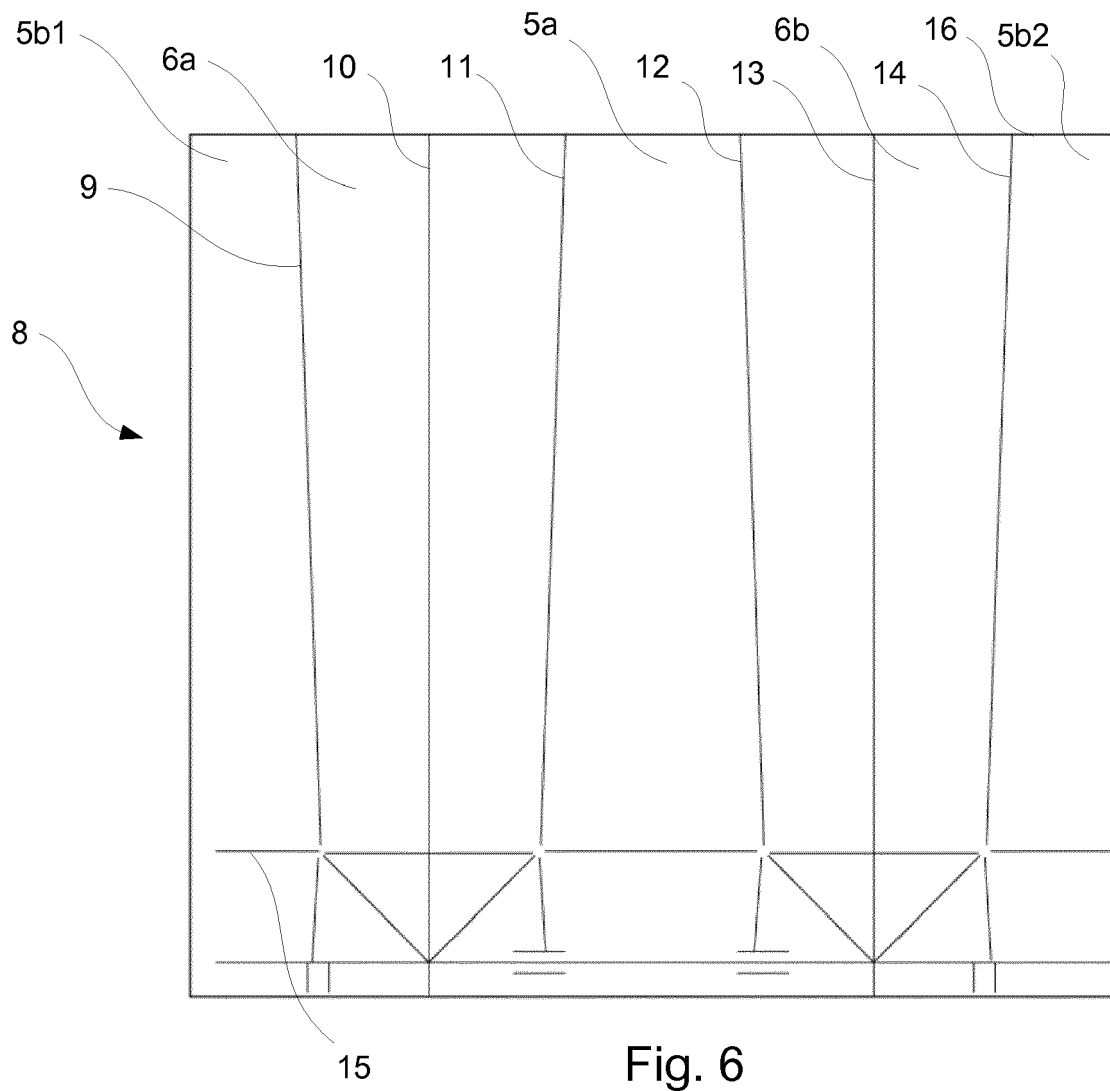

Fig. 6



EUROPEAN SEARCH REPORT

Application Number
EP 18 21 3550

5

10

15

20

25

30

35

40

45

50

55

DOCUMENTS CONSIDERED TO BE RELEVANT			
Category	Citation of document with indication, where appropriate, of relevant passages	Relevant to claim	CLASSIFICATION OF THE APPLICATION (IPC)
X A	WO 2011/120857 A1 (TETRA LAVAL HOLDINGS & FINANCE [CH]; HAYTON PAUL [GB]; PADAIN CHRISTOP) 6 October 2011 (2011-10-06) * page 5, line 24 - page 9, line 14; figures 1-4 *	11,13 1-10,12, 14	INV. B65D5/74 B65D8/00 B65D3/08
X A	EP 0 443 369 A2 (TETRA ALFA HOLDINGS [CH]) 28 August 1991 (1991-08-28) * column 8, line 36 - column 9, line 49; figures 1-11 *	11,13 1-10,12, 14	
X A	US D 448 285 S1 (PALM FREDRIK [SE] ET AL) 25 September 2001 (2001-09-25) * figures 1-2 *	11,13 1-10,12, 14	
A	JP H06 247435 A (DAINIPPON PRINTING CO LTD) 6 September 1994 (1994-09-06) * abstract; figures 1-5 *	1,11	
			TECHNICAL FIELDS SEARCHED (IPC)
			B65D
The present search report has been drawn up for all claims			
Place of search Munich		Date of completion of the search 9 May 2019	Examiner Grondin, David
CATEGORY OF CITED DOCUMENTS X : particularly relevant if taken alone Y : particularly relevant if combined with another document of the same category A : technological background O : non-written disclosure P : intermediate document T : theory or principle underlying the invention E : earlier patent document, but published on, or after the filing date D : document cited in the application L : document cited for other reasons & : member of the same patent family, corresponding document			

EPO FORM 1503 03/82 (P04C01)

ANNEX TO THE EUROPEAN SEARCH REPORT
ON EUROPEAN PATENT APPLICATION NO.

EP 18 21 3550

5 This annex lists the patent family members relating to the patent documents cited in the above-mentioned European search report.
The members are as contained in the European Patent Office EDP file on
The European Patent Office is in no way liable for these particulars which are merely given for the purpose of information.

09-05-2019

Patent document cited in search report	Publication date	Patent family member(s)	Publication date
WO 2011120857 A1	06-10-2011	AR 081447 A1	05-09-2012
		DK 2552791 T3	27-04-2015
		EP 2552791 A1	06-02-2013
		ES 2535817 T3	18-05-2015
		WO 2011120857 A1	06-10-2011

EP 0443369 A2	28-08-1991	DE 4005257 A1	29-08-1991
		EP 0443369 A2	28-08-1991
		JP H05338656 A	21-12-1993
		US 5103988 A	14-04-1992

US D448285 S1	25-09-2001	-----	
JP H06247435 A	06-09-1994	NONE	

EPO FORM P0459

For more details about this annex : see Official Journal of the European Patent Office, No. 12/82