

April 24, 1934.

R. N. DICKEY

1,955,847

FLOUR SIFTER

Filed Oct. 30, 1931

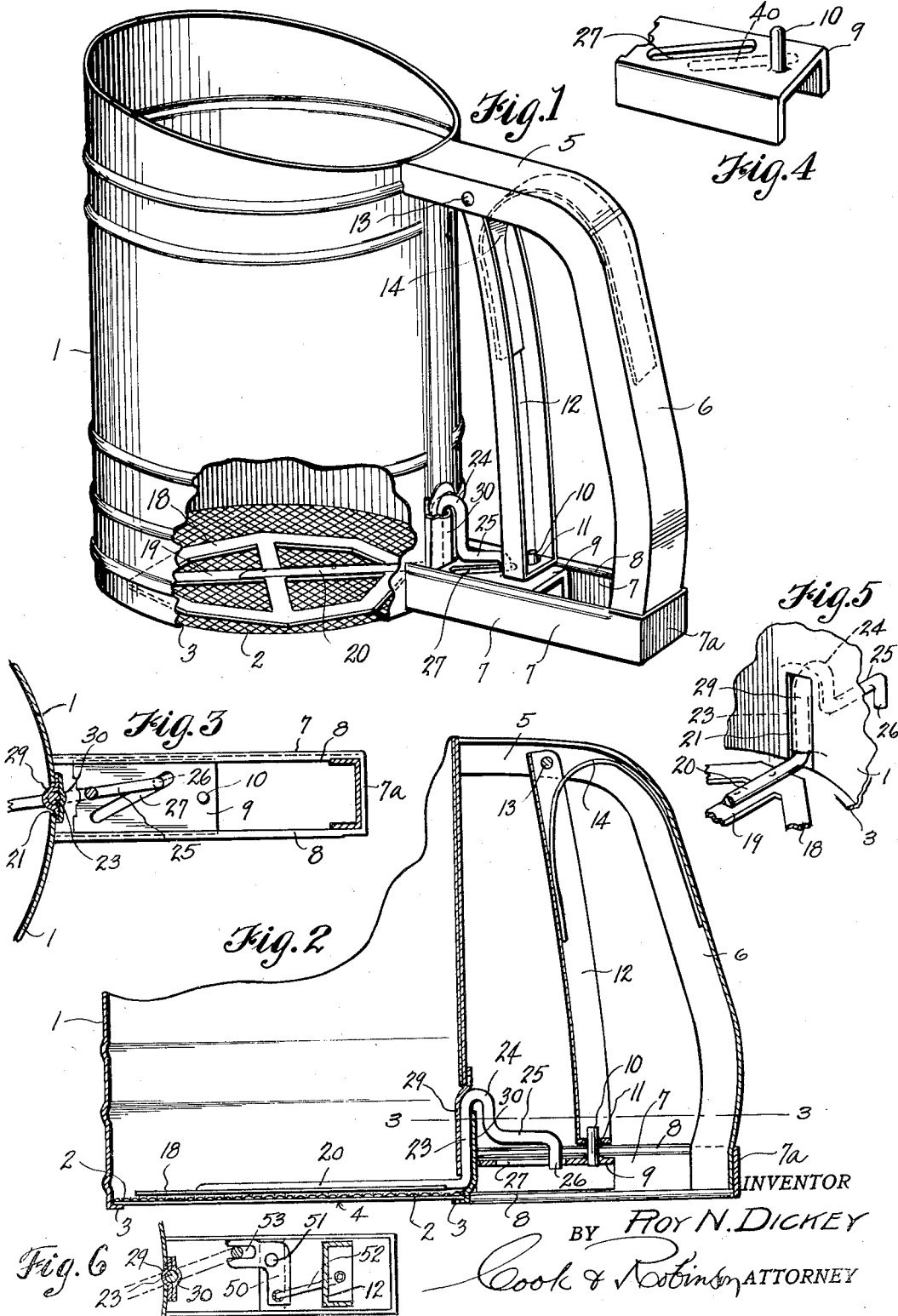

UNITED STATES PATENT OFFICE

1,955,847

FLOUR SIFTER

Roy N. Dickey, Seattle, Wash.

Application October 30, 1931, Serial No. 571,979

4 Claims. (Cl. 209—357)

This invention relates to sifting devices and more particularly to flour sifters and the like of that character in which the agitator is designed to be actuated by the hand that holds the sifter, 5 thereby leaving the other hand free for other uses; the present invention being in the nature of an improvement upon flour sifters of the same general character as that disclosed in United States Patent Number 1,488,306 issued to Rose 10 Adams on March 25, 1924.

It is the principal object of this invention to provide a flour sifter of the character above stated, that is rendered less expensive to manufacture 15 by reason of a novel manner and means for mounting and actuating the agitator and also because of various other details made possible by reason of the use of this particular agitator mechanism.

It is also an object of the invention to provide a flour sifter having a screened bottom upon which the agitator is oscillated to effect a sifting 20 operation, thereby making it practical to employ an actuating means that does not require any entrance opening through the screen.

More specifically stated, the present invention resides in the provision of a flour sifter comprising a flour holding receptacle of a size convenient to handle, having a screened bottom wall upon 30 which an agitator is disposed and having a handle member within which an actuating lever for the agitator is located; this being actuated in one direction by pressure of a spring and, in the other direction, by fingers of the hand which 35 grasps the handle.

It is also an object of the invention to provide connection between the lever and agitator through the medium of a slide block mounted in the handle and reciprocally actuated by the lever action; 40 and having a diagonal cam slot wherein a downturned end of the agitator crank arm extends so that reciprocal action of the slide effects oscillatory action of the agitator.

Other objects of the invention reside in the various details of construction and in the combination of parts and in their mode of operation, as will hereinafter be fully described.

In accomplishing these and other objects, I have provided the improved details of construction, the preferred forms of which are illustrated 50 in the accompanying drawing, wherein—

Fig. 1 is a perspective view of a flour sifter embodying the present invention, a part of the container wall being broken away for the purpose 55 of better illustration.

Fig. 2 is a vertical sectional view of the sifter showing the manner of mounting the agitator and the actuating block, and illustrating the connections between the block and agitator and lever.

Fig. 3 is a sectional detail taken substantially 60 on the line 3—3 in Fig. 2.

Fig. 4 is a perspective view of the slide block.

Fig. 5 is a perspective view of the agitator mounting as seen from the inside of the container.

Fig. 6 is a plan view illustrating an alternative 65 means for actuating the agitator.

Referring more in detail to the drawing—

1 designates a cylindrical sifter shell or casing, open at its upper and lower ends and having a screen 2 secured over the lower end. As shown 70 best in Fig. 2, the casing is seen to have an inturned flange 3 about its lower edge and to this the screen is soldered, or otherwise suitably fastened in a manner to preclude leakage.

Secured within the casing and extending diametrically thereacross, as a support for the screen 75 and as a brace for adding rigidity to the casing, is a flattened bar 4.

Secured to the side of the casing is a loop handle including an upper horizontal member 5 80 rounded at its outer end into a vertically directed member 6. The lower end of member 6 is fixed within the outer end of a lower horizontal brace consisting of parallel guides 7—7, these being 85 joined at their outer ends by an integral part 7a and are spaced apart and firmly secured at their inner ends to the casing. These two guides have their upper and lower longitudinal edges rolled inwardly to form retaining flanges 8 within which a slide 9 is supported for sliding 90 reciprocal action between the guides. This block, or slide, as seen in Fig. 4, comprises a flat plate with downturned longitudinal edge flanges of a width to fit nicely between the retaining flanges 8. The plate is provided at its outer end with a 95 stud 10 which projects slidably through a hole 11 in the lower end of the agitator actuating lever 12 which is pivotally mounted at its upper end by a pivot pin 13 within the upper horizontal member of the handle.

An inverted U-shaped leaf spring 14 is seated 100 within the handle with its base portion retained by the top member and its opposite leg portions bearing outwardly against the lever 12 and handle member 6 to urge the lever inwardly, and thereby 105 to move the slide block inwardly.

The handle member 6 is shaped to best suit the hand wherein it is held and the lever 12 is disposed in such relationship to the handle that it may be grasped by fingers of the hand which 110

holds the handle, and pulled outwardly against pressure of the spring.

Disposed upon the sifter screen within the casing is an agitator 18 here shown to be of octagonal outline and having diametrical cross ribs 19. Fastened securely upon one of these ribs is an actuating bar 20 whereby the agitator may be given an oscillating action upon the screen.

A feature of the present invention resides in the manner of pivotally mounting the agitator actuating bar and in its connection with the slide 9. By reference to Figs. 3 and 5 it will be noted that a vertical slot 21 is formed in the casing and extends upwardly from the lower edge of the casing centrally between the guides 7—7 forming the lower member of the handle, to a position somewhat above this member. The bar 20 is bent directly upward adjacent the edge of the agitator to provide a pivot portion 23 and is then bent outwardly and downwardly as at 24 then bent outwardly to provide a crank arm 25 overlying the slide and this arm is provided at its end with a downturned end 26 slidably contained within a slot 27 formed diagonally of the slide plate.

The pivot portion 23 of the agitator bar is rotatably mounted in a supporting bearing formed by inner and outer plates 29 and 30 applied to opposite sides of this part of the bar. By reference to Figs. 2 and 3 it will be observed that the plate 29 is placed against the outer surface of the casing to overlie the vertical slot 21 and it is formed with a semi-cylindrical depression extended longitudinally within the slot. Likewise, the plate 30 overlies the slot on the outside of the casing and it is formed with a semi-cylindrical depression registering with that of the other plate. The two pieces are so fitted to opposite sides of the pivot portion 23 of the bar that they form a supporting bearing therefor. Also, these two plates are soldered about their edges to the casing to hold the part secure and to prevent any leakage of flour through the slot. In Fig. 2 it is observed that the inner plate extends down to the horizontal portion of the agitator bar while the outer plate continues down to the lower edge of the container wall.

To use the device, flour would be scooped up in the casing in the usual manner, then by manipulation of the lever 12, outwardly manually and inwardly by action of the spring, the slide 9 will be reciprocated and this, by reason of the end 26 of the crank arm 25 extending into the cam slot 27 of the slide, will cause an oscillating action of the agitator to effect a sifting action.

In the event that a double sifting effect should be desired, this may be accomplished by use of two screens as in the patent issued to me on March 18, 1924, under Number 1,487,216 and two agitators employed, each with a crank arm as herein shown. Then the slide would be provided with another diagonal cam slot, as designated at 40 in dotted lines in Fig. 4, to receive the end of the added crank arm.

The alternative construction of Fig. 6 employs a rocker member 50 pivoted as at 51 to lower horizontal part 2 of the handle. At one end it is attached by a link 52 with the lower end of the actuating lever 12, and at its other end has a notch 53 for receiving the end of the agitator bar. With this construction, actuation of the lever causes an oscillating action of the rocker and this is translated to the agitator.

Devices of this character, while being substantial, serviceable and easily handled, are of a

comparatively inexpensive construction and may be made and sold at small cost.

It is to be understood that changes in details of construction might be made without departing from the spirit of the invention, and therefore, it is not desired that the claims be narrowly construed but that they be given an interpretation that is commensurate with the invention disclosed.

Having thus described my invention, what I claim as new therein and desire to secure by Letters Patent is—

1. In a sifter, a housing having a sifter bottom, an agitator disposed thereon, a handle attached to the housing, a hand lever movably mounted in the handle, a slide mounted in the handle and having a connection with the hand lever for movement thereby, and having a cam slot therein, and an actuating arm for the agitator having a portion thereof engaging the cam slot of the slide to effect its actuating movement incident to movement of the slide.

2. In a sifter of the character described, a housing having a screened bottom wall, an agitator disposed thereon, a handle attached to the housing having a part thereof forming a guideway, a slide reciprocally contained in the guideway and having a cam slot formed therein, a hand lever pivotally movable in the handle and having operative connection with the slide for reciprocating it; said agitator having an actuating rod attached thereto forming a pivotal mounting for the agitator and having an end portion forming a crank arm extending into the cam slot whereby reciprocal movement of the slide effects oscillating movement of the agitator.

3. A flour sifter of the character described comprising a housing having a screened bottom wall, a handle fixed to the housing at one side and formed with upper and lower attaching members and a connecting member therefor, a hand actuated lever pivotally mounted at its upper end in the vertical member, a spring bearing against the lever to urge it inwardly, said lower member of the handle forming a guideway, a slide reciprocally movable in the guideway having a diagonal cam slot therein, and having an operative connection with the lower end of the lever whereby movement of the lever effects reciprocal movement of the slide, an agitator disposed upon the screened bottom of the sifter, an actuating rod for the agitator secured thereto and having a portion journaled pivotally within a side wall bearing of the housing and formed with a crank arm at the outside of the housing having a downturned end portion contained within the cam slot for actuating the agitator.

4. In a sifter of the character described, a housing having a screened bottom wall, a handle attached to the housing a slide reciprocally contained in the handle, a hand lever associated with the handle and operable to actuate the slide, an agitator mounted upon the screened bottom wall having an actuating rod fixed thereto and formed with a journal portion and terminating at the outside of the housing in a crank arm operatively connected with the slide for actuation thereby; said housing having a slot formed therein for the passage of the actuating rod and bearing plates fitted to the journal portion of the rod to operatively mount it and overlying the said slot and secured to the housing about the slot.