

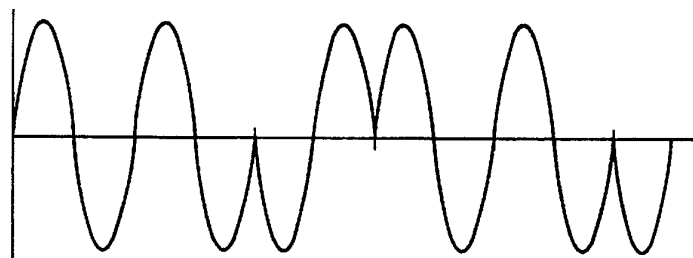

INTERNATIONAL APPLICATION PUBLISHED UNDER THE PATENT COOPERATION TREATY (PCT)

(51) International Patent Classification ⁶ : G08C 17/04, H04B 5/00	A1	(11) International Publication Number: WO 95/07521 (43) International Publication Date: 16 March 1995 (16.03.95)
(21) International Application Number: PCT/GB94/01962 (22) International Filing Date: 8 September 1994 (08.09.94) (30) Priority Data: 9319044.5 11 September 1993 (11.09.93) GB (71) Applicant (for all designated States except US): RENISHAW PLC [GB/GB]; New Mills, Wotton-Under-Edge, Gloucestershire GL12 8JR (GB). (72) Inventor; and (75) Inventor/Applicant (for US only): THOMAS, David, Kenneth [GB/GB]; Rose Cottage, Taits Hill Road, Stinchcombe, Dursley, Gloucestershire GL11 6PR (GB). (74) Agent: JACKSON, John, Timothy; Renishaw plc, Patent Dept., New Mills, Wotton-Under-Edge, Gloucestershire GL12 8JR (GB).		(81) Designated States: JP, US, European patent (AT, BE, CH, DE, DK, ES, FR, GB, GR, IE, IT, LU, MC, NL, PT, SE). Published <i>With international search report.</i>

(54) Title: SIGNAL TRANSMISSION SYSTEM FOR PROBES

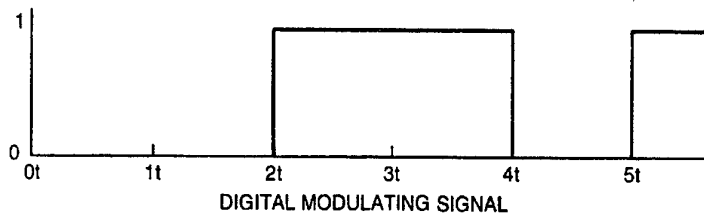

(57) Abstract

An inductive transmission system for a probe for use on a coordinate positioning machine such as a machine tool. The probe (10) is connected via a probe interface (14) to a single coil (16). This is inductively coupled across a small gap to a second coil (30), which is connected via an interface circuit (12) to the machine control. Data signals pass from the probe (10) to the interface (12). Simultaneously, a power carrier signal and a command signal pass from the interface (12) to the probe (10). In order that all these signals can pass without mutual interference via the coils (16, 30), each signal has a carrier of a different frequency, and the signals are carried in frequency bands which do not overlap.

FOR THE PURPOSES OF INFORMATION ONLY

Codes used to identify States party to the PCT on the front pages of pamphlets publishing international applications under the PCT.

AT	Austria	GB	United Kingdom	MR	Mauritania
AU	Australia	GE	Georgia	MW	Malawi
BB	Barbados	GN	Guinea	NE	Niger
BE	Belgium	GR	Greece	NL	Netherlands
BF	Burkina Faso	HU	Hungary	NO	Norway
BG	Bulgaria	IE	Ireland	NZ	New Zealand
BJ	Benin	IT	Italy	PL	Poland
BR	Brazil	JP	Japan	PT	Portugal
BY	Belarus	KE	Kenya	RO	Romania
CA	Canada	KG	Kyrgystan	RU	Russian Federation
CF	Central African Republic	KP	Democratic People's Republic of Korea	SD	Sudan
CG	Congo	KR	Republic of Korea	SE	Sweden
CH	Switzerland	KZ	Kazakhstan	SI	Slovenia
CI	Côte d'Ivoire	LI	Liechtenstein	SK	Slovakia
CM	Cameroon	LK	Sri Lanka	SN	Senegal
CN	China	LU	Luxembourg	TD	Chad
CS	Czechoslovakia	LV	Latvia	TG	Togo
CZ	Czech Republic	MC	Monaco	TJ	Tajikistan
DE	Germany	MD	Republic of Moldova	TT	Trinidad and Tobago
DK	Denmark	MG	Madagascar	UA	Ukraine
ES	Spain	ML	Mali	US	United States of America
FI	Finland	MN	Mongolia	UZ	Uzbekistan
FR	France			VN	Viet Nam
GA	Gabon				

SIGNAL TRANSMISSION SYSTEM FOR PROBES

This invention relates to a signal transmission system. It is especially useful for probes as used for measurement in coordinate positioning machines such as machine tools, coordinate measuring machines, measuring robots and the like.

An embodiment of the invention will be described by way of example with reference to the accompanying drawings, wherein:

Fig 1 is a block diagram of a signal transmission system,

Figs 2A and 2B are block diagrams showing alternative arrangements of the system of Fig 1,

Fig 3 is a more detailed block diagram of the system,

Fig 4 is a graph showing the frequencies of signals in the system,

Figs 5A and 5B are waveforms of possible data signals in the system,

Figs 6A, 6B, 7A, 7B and 8 are circuit diagrams of components of the system,

Fig 9 is a table for explaining the circuit of Fig 8,

Figs 10, 11 and 12 are circuit diagrams of further components of the system,

Fig 13 is a graph corresponding to Fig 4, but showing an alternative,

Fig 14 is a block diagram of part of another alternative system,

Fig 15 is a circuit diagram of a component in Fig 14.

The transmission system which will be described is intended for installation on a machine tool, such as a machining centre or lathe. As is well known, such a machine tool may have, in addition to the usual cutting tools, a measuring probe which can be picked up in a spindle of the machine, or mounted at a tool-holding position on a turret of a lathe, so as to be movable with respect to a workpiece.

Such a probe can then be used for measurements on the workpiece.

Fig 1 is a block diagram giving a general overview of a
5 signal transmission system for such a probe 10. The probe must be able to communicate with a transmission interface 12, which interfaces it to the CNC or other control of the machine tool (not shown). However, in the majority of machine tool installations, it is not possible simply to
10 hard wire the probe 10 to the interface 12, for example because of the requirement to automatically exchange the probe for cutting tools, or to move the probe between operative and inoperative positions. Consequently, Fig 1 shows inductive coupling units, which enable the signals to
15 pass wirelessly across small gaps (e.g. up to about 2mm or 3mm). Inside the probe 10, or mounted with it, is a probe interface circuit 14, connected to an inductive module 16 by a twin wire 18. The module 16 comprises a single coil, which is inductively coupled to another single coil in a
20 module 20, across a gap 22. The module 20 is linked by a co-axial cable 24 to another inductive module 26. This in turn is linked inductively across a gap 28 to yet another inductive module 30. The modules 26,30 again each comprise a single coil. Finally, a co-axial cable 32 links the
25 module 30 to the transmission interface 12 and thence to the machine tool control.

In the following description, the module 16 will be referenced by the abbreviation IMP (Inductive Module,
30 Probe). The module 30 will be termed IMM (Inductive Module, Machine). The modules 20,26, which may be identical for convenience, will be termed IMI (Inductive Module, Intermediate).

35 The system shown in Fig 1 is intended for use in machine tool installations requiring the two gaps 22,28. For example, such a system might be used in a lathe, with one gap between the probe and the tool-holding turret, and

another gap between the turret and the carriage or slide upon on which it is mounted. In many installations, however, only a single gap will be necessary. Fig 2A shows such an arrangement, in which the IMI's 20,26 and the cable 5 24 are omitted. The IMP 16 and IMM 30 are simply mounted so that they are brought into proximity when the probe is in use, with a single gap of up to say 8mm between them. As shown in Fig 2B, it is also possible to use the present system in a purely hard wired installation. In this case, 10 the modules 16,30 are both omitted, and the co-axial cable 32 is connected to the twin wires 18 via a simple terminator 34, which provides impedance matching.

The system will now be described in more detail.

15

It should be understood that the probe 10 may be any of a number of widely different types. For example, it may be a touch trigger probe which simply generates a trigger signal when a deflectable stylus 11 contacts a workpiece surface. 20 At the opposite extreme, it may be a three axis measurement or scanning probe, containing transducers for measuring the amount of movement of the stylus 11 relative to the probe body in each of three axes x,y,z. Especially if used for scanning purposes, such a probe may capture data at a high 25 rate, requiring a correspondingly high rate of data transmission. Between these extremes, the signal transmission system may also be used for other types of probe, including non-contact probes such as optical triangulation probes which generate measurement data only 30 for a single axis. In addition to the requirements of signal transmission from the probe 10 to the transmission interface 12, the various types of probe may have different requirements for power supplies which must also be transmitted through the cables and inductive couplings 35 described. Optionally, it may also be desired to transmit control signals to the probe from the transmission interface 12.

These various requirements are met by transmitting the various signals on carriers in different parts of the frequency spectrum, as shown in Fig 4. Power is transmitted from the interface 12 to the probe in the form of a 60kHz carrier 36. Data from the probe back to the interface 12 is transmitted in a data band 38 extending from approximately 500kHz to 5MHz. Commands are transmitted, if desired, in a command band 40 which is narrower than the data band 38, and is centred around a 210kHz carrier.

Data is modulated on a 2MHz or 2.5MHz carrier in the data band 38 using a modulation system with constant amplitude. Where the probe requires a high speed of data transmission (a high data rate) it is transmitted in digital form by differential phase shift reversal key modulation (DPRK). This is illustrated in Figs 5A and 5B. The waveform in Fig 5A shows the digital modulating signal, and the waveform in Fig 5B shows the modulated carrier signal, having phase reversals corresponding to the modulating signal.

Alternatively, where a lower speed of digital data transmission can be tolerated, frequency shift key (FSK) modulation can be used, in which successive 0's and 1's of the digital modulating signal are represented by shifting the frequency of the carrier to a higher or lower value. For example, the carrier frequency may shift between 1.5MHz and 2.5MHz. As an alternative to such digital data transmission, it is possible to modulate analogue information onto the data carrier, e.g. by wideband frequency modulation; the bandwidth of the data band 38 is even wide enough to carry video information if the probe is a video probe. Command signals in the command band 40 are preferably carried by narrow band FSK modulation.

Modulation systems with constant amplitude are chosen for the command band 40 and data band 38 because they have high noise immunity and the ability to accommodate wide variations in signal amplitude. This latter feature is

important because of the possible presence of one or a plurality of inductive gaps 22,28 in the transmission system, or possibly no gap at all as shown in Fig 2B. The presence or absence of one or more such gaps causes very wide variations in the amplitudes of the transmitted signals.

Of course, other frequencies may be chosen for the various signals shown in Fig 4. For example, it would be possible for power carrier 36 to have a higher frequency than the command and data bands 40,38. The frequencies shown in Fig 4 are preferred for the following reasons. The 60kHz frequency for the power carrier 36 is chosen on the grounds of losses within the various connecting cables and on considerations of the size of capacitive and inductive components within the inductive coupling modules 16,20,26,30. If the power carrier frequency 36 is too low, these components will need to be too large to fit into a conveniently sized package. On the other hand, losses in the cables, and the need for correct termination to prevent transmission line effects, increase with the frequency of the power carrier. This is a particular problem, since it is desired to have the ability to use a long cable, e.g. up to 100m for the co-axial cable 32. It is also necessary to take account of the very significant power losses across the inductive gaps 22,28, if present. Normally, the power loss across one of these gaps would be the square of the voltage loss, giving rise to a very great problem. However, this problem is alleviated somewhat as discussed below by tuning each of the coupling modules 16,20,26,30 to the frequency of the power carrier, so that the power loss has the same ratio as the voltage loss.

Another factor affecting the choice of the frequencies shown in Fig 4 is that the bandwidths of the data band 38 and command band 40 must not overlap that of the power carrier 36, as the various signals have to be separate for signal generation and recovery in the probe interface 14

and transmission interface 12. The transmission interface 12 has the more stringent requirement because the ratio of the transmitted power voltage to the received signal voltage (data band 38) may be of the order 10^5 . Careful
5 filtering is therefore needed to ensure that the power carrier does not overload the data receiver in the interface 12. To achieve this, the desirable minimum ratio between the data carrier frequency and the power frequency should be around 10. Furthermore, the carrier frequency
10 210kHz for the command band 40 is chosen so as to give maximum separation from the harmonics of the 60kHz power carrier which occur at 180kHz and 240kHz.

Of course, it should be appreciated that the above values
15 relate to the present preferred embodiment of the invention, and may differ in other embodiments.

Co-axial cables are chosen for the cables 24,32 in the preferred embodiment because they are fully screened,
20 easily available and have relatively low losses. It is also important that they have well defined transmission line characteristics since it is desired to be able to use long lengths of up to 100m, and because they are mechanically robust in bending and generally small in
25 diameter. This makes them easier to install on a machine tool. 50 Ω cable is preferred because it is cheap and has a low resistance at low frequencies.

Referring now to Fig 3, various components of the system
30 will be described in more detail.

In the transmission interface 12, a 60kHz power carrier generator 50 is powered by a DC power supply 52. It supplies the necessary power to the IMM 30 via the cable 32
35 and a splitter/combiner circuit 54. Probe signals in the data band 38 are routed by the splitter/combiner 54 to an FSK or DPRK decoder 56. In turn, this passes the decoded signals to outputs 58 leading to the control of the machine

tool, via a machine interface logic circuit 60. If it is required to send command signals to the probe, these are received from the machine control on input 62, and the logic circuit 60 passes them to an optional command driver circuit 64 which modulates them onto the 210kHz carrier. This then passes via the splitter/combiner 54 and cable 32 to the IMM 30.

The power generator 50 is configured to give a constant power output to the IMM so that the dissipation in this module is constant and the induced voltage in the coupled coil within the IMI 26 or IMP 16 does not increase rapidly as the gap between the modules decreases. This is advantageous because at small gaps, the approach of the coil in the IMI 26 or IMP 16 detunes the IMM 30 and reduces the load impedance seen by the power generator 50. Without the constant power output, this would have the effect of increasing the power dissipated in the IMM whilst the induced voltage in the other coil coupled to it would be increased because of the smaller gap.

Entirely different data decoders 56 are used, depending whether DPRK or FSK modulation is required. Block diagrams of the two systems are shown in Figs 6A and 6B respectively. Both have the same problem in that the residual power carrier left over from the splitter 54 must be suppressed below the data signal level, as must the power carrier harmonics. A 100:1 variation in input signal must also be accommodated before the actual detection is carried out. In the DPRK system (Fig 6A) there is a signal preamplifier 66 which is followed by a multi-pole linear phase high pass filter 68 at 500kHz. This is used to suppress most of the residual power carrier and its harmonics to leave almost only the probe data signal; the type of filter is specifically designed to minimise phase distortion and hence signal corruption. The zero crossings of the data signal are detected by a comparator 70 before a

digital shift register chain 72 is used to recover the original signal.

The FSK decoder (Fig 6B) comprises a narrow band amplifier 5
74 centred at 2MHz. This feeds a passive bandpass filter 76 also centred at 2MHz which is followed by a limiter amplifier 78 to give a constant amplitude signal into two phase locked loop detectors 80,82. In the preferred embodiment, the 1's and 0's of the digital signal are
10 represented by frequencies of 2.5MHz and 1.5MHz, and the phase locked loop detectors 80,82 detect these frequencies respectively. Their outputs are then fed to decoding logic circuits 84, which may comprise window comparators that regenerate the original signal.

15

The splitter/combiner 54 comprises a set of two or three passive filters, arranged to give a constant 50 Ω impedance throughout the spectrum of the data band 38 and command band 40. This then gives good impedance matching and
20 transmission line characteristics for the 50 Ω co-axial cable 32. Fig 7A shows a two filter version. A first filter 84 is bandpass tuned to the 60kHz power carrier, whilst a second filter 86 is a high pass filter which receives the data signals from the cable 32 and passes them
25 to the decoder 56. As shown in Fig 7A, the second filter 86 has a 150kHz cut off frequency.

The more complex version of the splitter/combiner 54 is shown in Fig 7B, and allows for the optional command
30 signals received from the command driver 64. It comprises the filters 84,86 as previously, except that the filter 86 now has a 500kHz cut off frequency so as to reject the 210kHz signals from the command driver 64. Optionally, there may be a third filter (not shown) centred at 210kHz
35 and used for injecting the command carrier signal. A transformer based four port directional coupler 88 is also fitted, to reduce the leakage of the command signal into

the data decoder 56. The directional coupler 88 is illustrated in more detail in Fig 8.

In Fig 8, the impedances of the various inputs/outputs
5 A,B,C,D are represented by Z_a, Z_b, Z_c, Z_d . By ensuring that
 $Z_a/Z_b = Z_c/Z_d$, and by determining the transformer ratios in
accordance with these impedances, an input appearing at
given one of the ports A-D will appear as an output at two
other ports, with the fourth port giving a null output, in
10 accordance with the table shown in Fig 9.

The purpose of the filters in the splitter/combiner 54 is
to allow the power carrier to pass through to the cable 32
with little loss whilst the return probe data signal enters
15 the decoder 56 with only residual levels of power carrier
or command carrier present. This is important as the power
carrier amplitude is up to 30V and the probe data signal
can be as small as $500\mu V$ and some primary separation of the
probe data signal is necessary before the decoder to avoid
20 overload. In designing the inductors in the various
filters, care should be taken to avoid causing harmonic
distortion in the power carrier. Otherwise, the higher
power carrier harmonics will appear in the data band 38 or
command band 40 and can cause detection problems if they
25 are not small compared with the wanted signals.

Fig 10 shows the circuit of the IMM 30. A coupling coil 90
is wound on a ferrite core 92, which improves the coupling
to the corresponding coupling coil in the IMI 26 or IMP 16.
30 The IMM 30 is the most complex of the coupling modules as
it has three tasks to perform: the first is to allow the
power carrier to be coupled efficiently to the next module,
the second is to allow the probe data signal to be
transmitted with low levels of phase and frequency
35 distortion, the last is to present to the cable 32 an
impedance of 50Ω over the data band 38 and the command band
40 to terminate the co-axial cable correctly. For
efficient power transfer and minimum power drain on the

power generator 50 the IMM must be tuned to the power frequency and this needs a capacitor 94 in parallel with the coupling coil to give a high impedance at the power frequency. Two additional inductors, three other capacitors
5 and two resistors are needed to match to 50Ω in the data band and give a flat frequency response. The IMM matches to 50Ω over the range 150kHz to 6MHz and the signal channel has -3 dB points at 170kHz and 5MHz.

10 The IMI's 20,26 are designed to be as simple as possible with only three auxiliary resistors and capacitors in addition to a coupling coil 96, ferrite core 98 and main tuning capacitor 100 (Fig 11). The impedance matching is imperfect which gives rise to a maximum length of 5m for
15 the cable 24 to limit data signal loss and distortion; most double gap systems need less than 2m of cable between units.

The IMP 16 is just a simple coil 102 (Fig 12) with a
20 ferrite core 104, and the two wires 18 from the coil are connected to the probe interface 14. For long lengths and for interference prevention these wires may need to be screened.

25 As shown in Fig 2B, the system can be used without any inductive couplers with a single co-axial cable link down to the probe interface and with a cable termination network 34 replacing the IMP. This network comprises a resistor to match to the cable impedance and a transformer to give
30 ground isolation; the two wire output of the network goes direct to the probe interface.

Referring again to Fig 12, the probe interface 14 is tuned to the power carrier by a capacitor 106 in parallel with
35 the IMP coil which feeds a rectifier 108 and power supply circuit 110 to provide DC for the probe signal conditioner and probe interface power supplies. The major limitation on the design of the probe interface is the need to inject

the probe data signal into the transmission link. This is done by a small transformer 112 in series with the IMP coil which is driven via a coupling capacitor 114 by a drive amplifier 116, this arrangement forms a high pass filter which cuts off at 500kHz. Because the transformer is in series with the IMP coil a fraction of the power carrier voltage appears across it and hence, even with the high pass filter, at the output of the drive amplifier. The amount of power carrier voltage at the output of the drive amplifier must not be too large otherwise the probe data signal will be distorted as the amplifier fails to absorb the current. This is the point at which the system overloads with high drive levels and small gaps. There is a complex trade-off between the IMP coil inductance, the transformer ratio, the transformer inductance, the coupling capacitance value and the maximum and minimum gaps that can be obtained. This trade-off also controls the amount of power that can be transferred over small single gaps as a significant portion of the available power is absorbed by the drive amplifier 116. The drive amplifier is run from +/-5V to permit the use of a suitable amplifier and produce the output swing to drive the cable, the drive level is around 6V pp. All of this appears across the IMP coil as the tuning capacitor has a very small impedance at high frequency and so the transformer winding is effectively connected across the IMP coil.

In Fig 3, there are shown various alternative forms of probe 10 and probe interface 14 which may be connected to the IMP 16. In one simple variant, a touch trigger probe 10a comprises conventional mechanical components 120, transducer 122 and signal conditioner 124. This is connected to a probe interface circuit referenced 14a, containing the power supply components 108,110 shown in Fig 12. The tuning and transformer components 106,112,114 are indicated by a block 126 in the circuit 14a. Finally, the signal output from the signal conditioner 124 is FSK

modulated and fed to the drive amplifier 116, in a block labelled 128.

Reference numerals 10b and 14b in Fig 3 indicate an
5 alternative probe using DPRK modulation. This may for example be a three axis measurement or scanning probe. Similar reference numerals have been used as in the probe 10a and interface 14a, where appropriate, though of course different components will be used for the different type of
10 probe. Here, a DPRK logic circuit 130 is used to modulate the output of the signal conditioner 124, before feeding it to the drive amplifier 116 of Fig 12.

The FSK modulator 128 can be built directly round the drive
15 amplifier 116 making this very easy to implement, whilst most of the DPRK modulator 130 is digital with the drive amplifier 116 filtering the digital input into an approximate sinusoidal waveform. The digital parts need a basic clock frequency of 10MHz which is divided down and
20 combined with the data input to generate the necessary waveform. This logic can be provided together with the signal conditioner 124 in an application specific integrated circuit (ASIC) or it could be in a gate array if an independent modulator is required, but at greater
25 expense in cost and power.

A probe with an interface for the optional command signals in the command band 40 is shown at 10c,14c in Fig 3. In this case, the circuit shown in Fig 12 includes an
30 additional band pass filter 140, tuned to the 210kHz carrier frequency, and connected to the transformer 112. This performs the primary separation for the command signal against both the power carrier and the data signal. It is a small signal at this point, just like the data signal on
35 arrival at the transmission interface 12. The power carrier rectification in the probe interface generates substantial harmonics of the 60kHz frequency, which would interfere with the command signal if its bandwidth and

centre frequency were not controlled. Command signal detection is performed by a commercial FSK demodulator integrated circuit 142 designed for radio use. This device has full superheterodyne provision with a local oscillator, 5 mixer and intermediate frequency strip as well as an FSK detector. A standard intermediate frequency of 455kHz may be used as the filters for this are readily obtainable. This entails a local oscillator frequency of 245kHz and an additional image trap filter 144 at 700kHz to reject any 10 data signal content around this frequency.

As so far described, this system is intended for use with only one probe at a time, and may be configured for any of the different probe types shown in Fig 3. However, some 15 machine tool installations require two or more probes, which may or may not be identical. This may be achieved as follows.

In one possible arrangement, the transmission interface 12 20 contains a switch 150, connected to the splitter/combiner 54 and controlled by the machine control via the machine interface logic 60. This simply switches in a completely separate probe with its own transmission system, whenever required. The separate transmission system has its own 25 cables 32,24,18 and inductive couplings 30,26,20,16 as required.

An alternative arrangement shown in Figs 13-15 allows the use of two or more probes simultaneously. As seen in Fig 30 13, the data band 38 of Fig 4 is divided into two separate bands 38a,38b, one for each probe. The data modulator in each probe uses a carrier frequency centred in its respective band, and the transmission interface 12 contains the necessary filters and individual decoders 56 to 35 separate the signals from the two probes. Both probes are powered from the 60kHz carrier, and each may optionally be capable of receiving suitably coded control signals in the command band 40. This can be done by allocating each probe

an address which is sent at the start of any command sequence.

Fig 14 shows how two such probes can be connected into the signal transmission system. Here, they are shown connected into the cable 32 at a convenient point between the transmission interface 12 and the IMM 30, via a hybrid junction 154 described below. Each probe has its own IMM 30, which may be coupled to an IMI 26 as shown in Fig 1, or directly to an IMP 16 as shown in Fig 2A. Hard wired connections as shown in Fig 2B are also possible. It is also possible to place the junction 154 in the cable 24 between the IMI's 20,26 of Fig 1, if desired.

Hybrids, as used for the junction 154, are passive four port circuits that can be used to split or combine two signal sources onto a single transmission line while maintaining the impedance match and avoiding mutual interference. Fig 15 shows a transformer based circuit as an example. A signal entering at port A will split equally between adjacent ports B and C with no signal reaching port D. The same is true of a signal entering at port B which will split between ports A and D with none at C. Like all transmission line circuits the ports must be correctly terminated. The hybrid is used for combining two probes in the following way: the interface feeds port A so that the power at 60kHz splits equally between B and C. The two probes are connected to B and C so that the data signals split between A and D with no crosstalk between the probes. The port D has a dummy load 156 with 25Ω impedance.

Of course, the signals could be split and combined by other RF engineering techniques, if desired. Another possibility, rather than using separate data bands 38a,38b, is for each probe to transmit data in the same band 38, but only when commanded to do so by a command signal in the command band 40.

The system shown in Fig 1 has two gaps 22,28. Three or more gaps may be provided if required, by duplicating the IMI's 20,26 and cable 24. However, the size of the gaps will then need to be quite small to reduce losses.

CLAIMS

1. An inductive transmission system for a probe for use on a coordinate positioning machine, comprising a first coil associated with the probe, and a second coil associated with the machine, said coils being separated by a gap and being inductively coupled together for transmission of signals across the gap, a plurality of signal generating means, each signal generating means being connected to one of said coils for transmission of a corresponding signal across the gap to the other coil, each of said signal generating means generating its signal on a carrier having a frequency different from the other signal generating means.
2. A system according to claim 1, wherein one of the signal generating means is located in the probe and is connected to the first coil, for transmission of probe data signals from the probe to the machine.
3. A system according to claim 1 or claim 2, wherein one of the signal generating means generates a power carrier and is located in association with the machine and is connected to the second coil, for transmission of power to the probe.
4. A system according to any one of the preceding claims, wherein one of the signal generating means is located in association with the machine and is connected to the second coil, for transmission of command or control signals to the probe.
5. A circuit for association with a probe in a system according to claim 2, comprising said first coil and said signal generating means for transmitting probe data signals across the gap from the probe to the machine; and further comprising means for receiving a signal transmitted across

the gap from a further one of said signal generating means located in association with the machine.

6. A circuit for association with a machine in a system according to claim 2, comprising said second coil and means for receiving probe data signals transmitted across the gap from the probe to the machine; and further comprising at least one of said signal generating means for transmitting signals across the gap from the machine to the probe.

1/9
Fig. 1. COUPLING ARRANGEMENTS

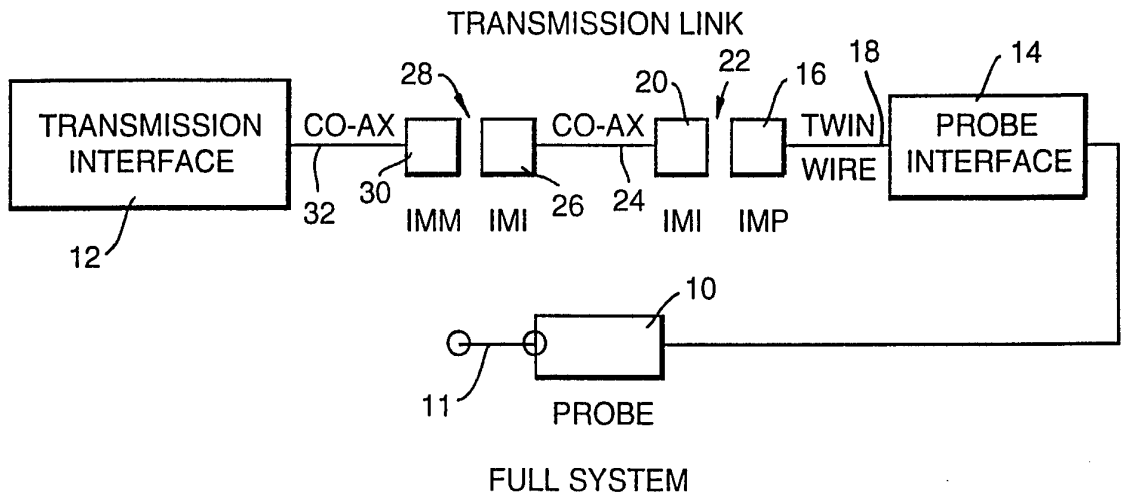

Fig. 2A.

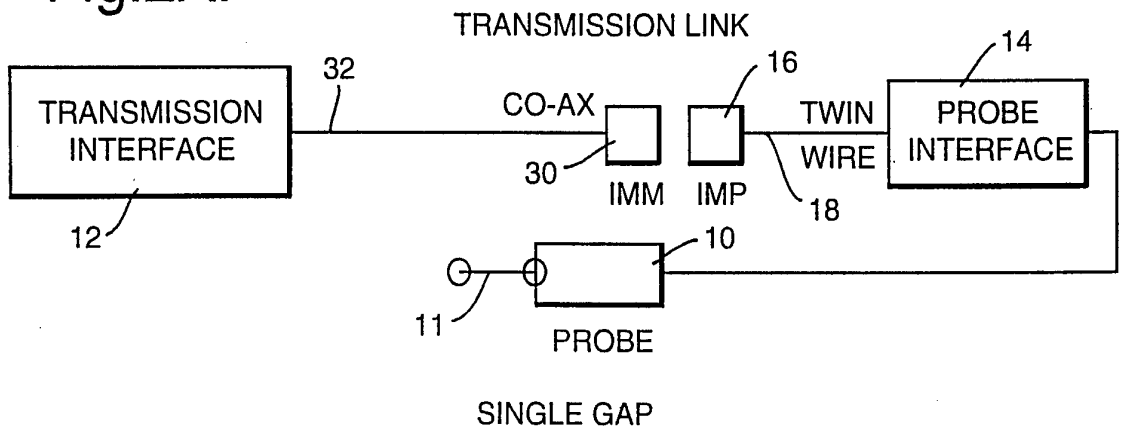
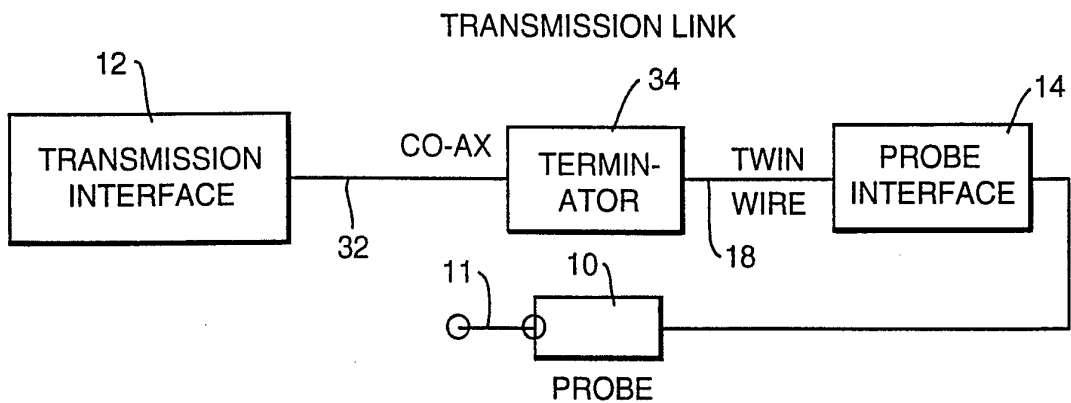

Fig. 2B.



2/9

BLOCK DIAGRAM, INDUCTIVE TRANSMISSION

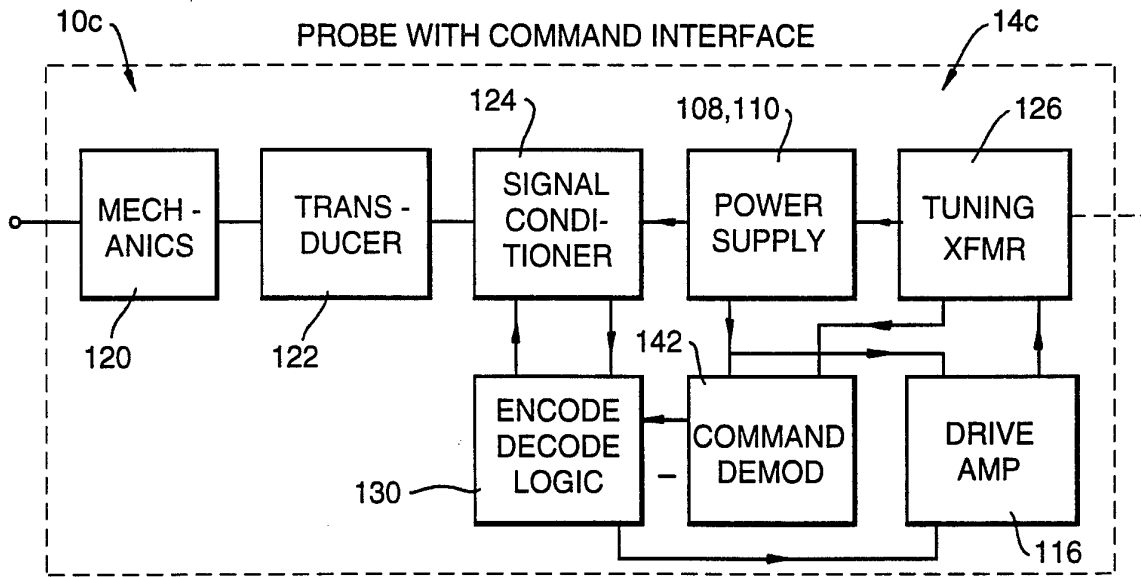
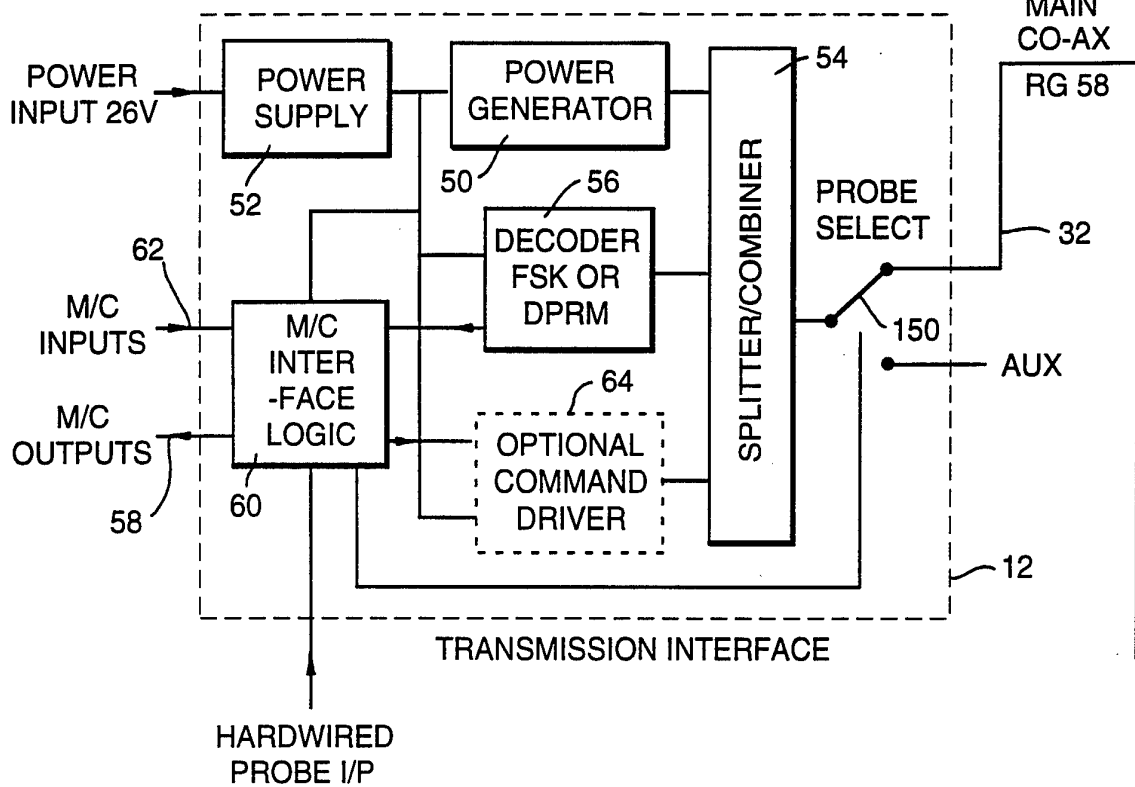

Fig.3.

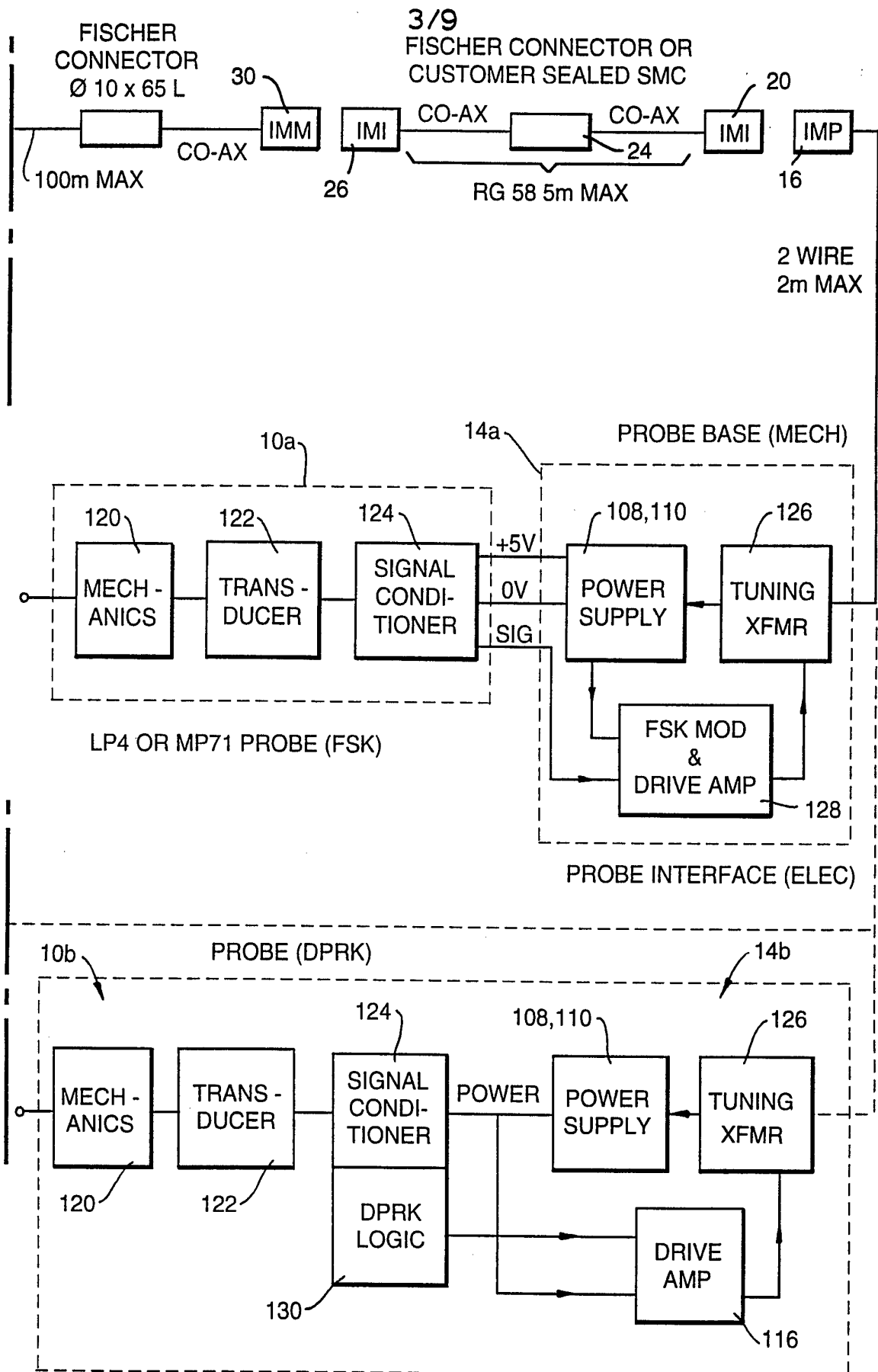

Fig.3(Cont.)

Fig.4.

4/9
FREQUENCY SPECTRUM, INDUCTIVE TRANSMISSION

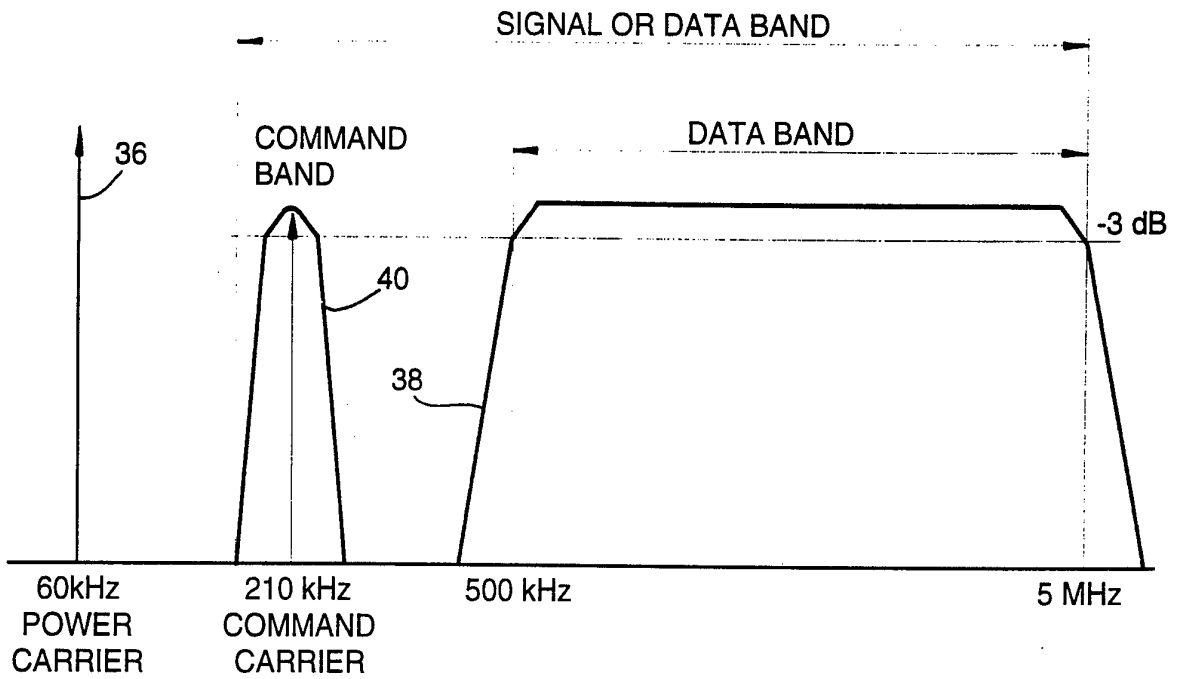

Fig.5A.

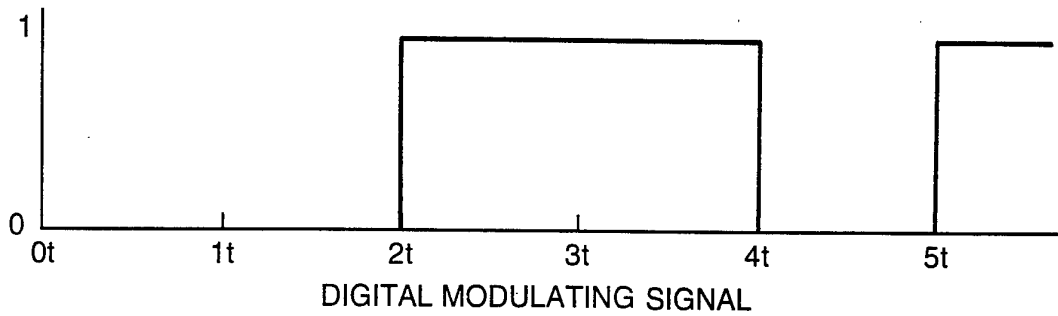
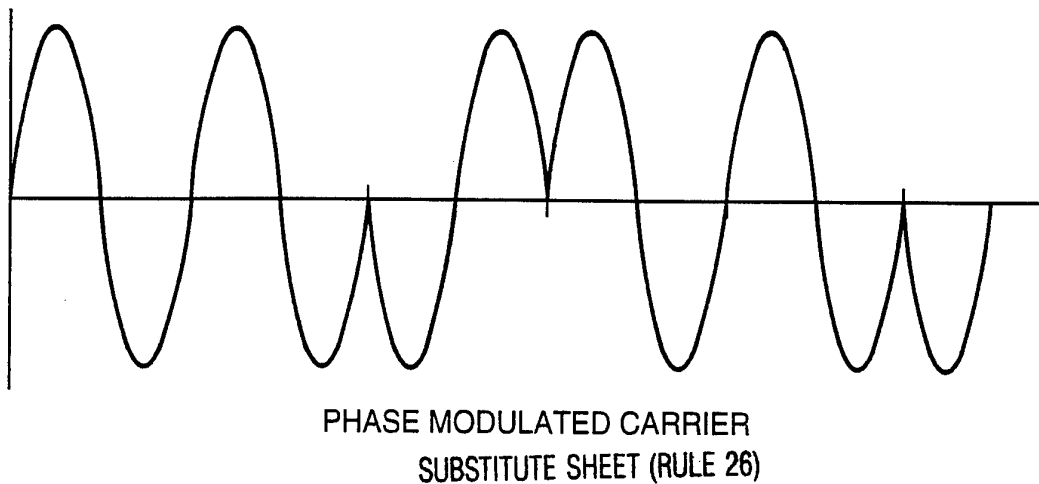

Fig.5B.



PHASE MODULATED CARRIER
SUBSTITUTE SHEET (RULE 26)

Fig.6A.

5/9

DATA DECODER, DPRK

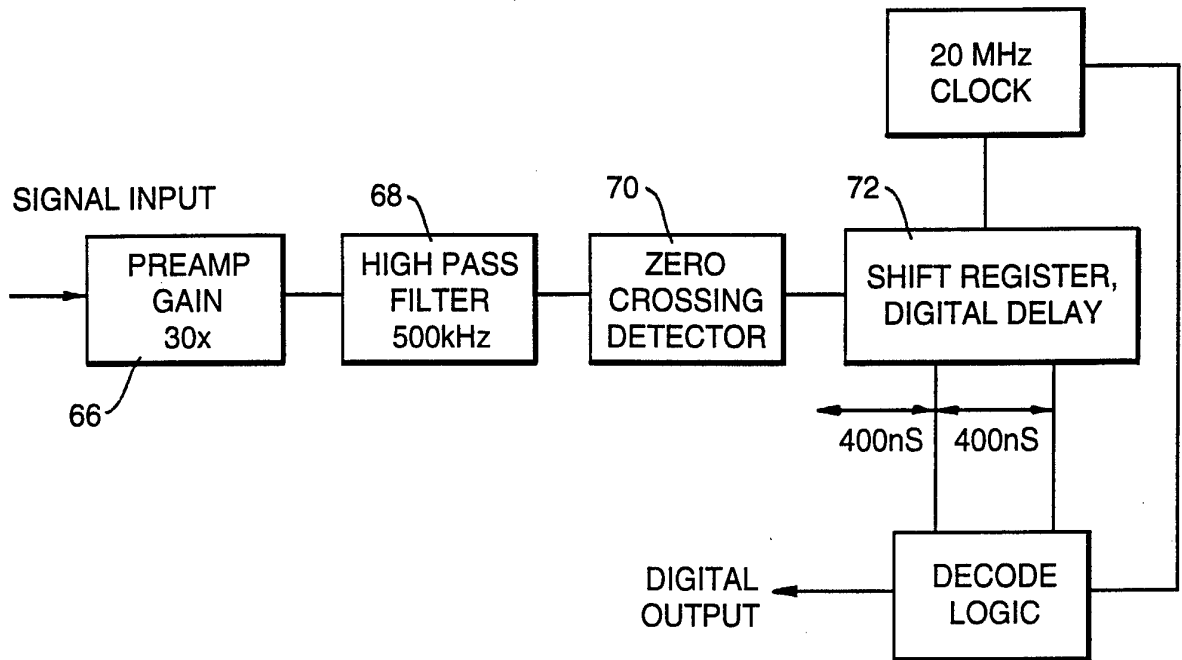

Fig.6B.

DATA DECODER, FSK

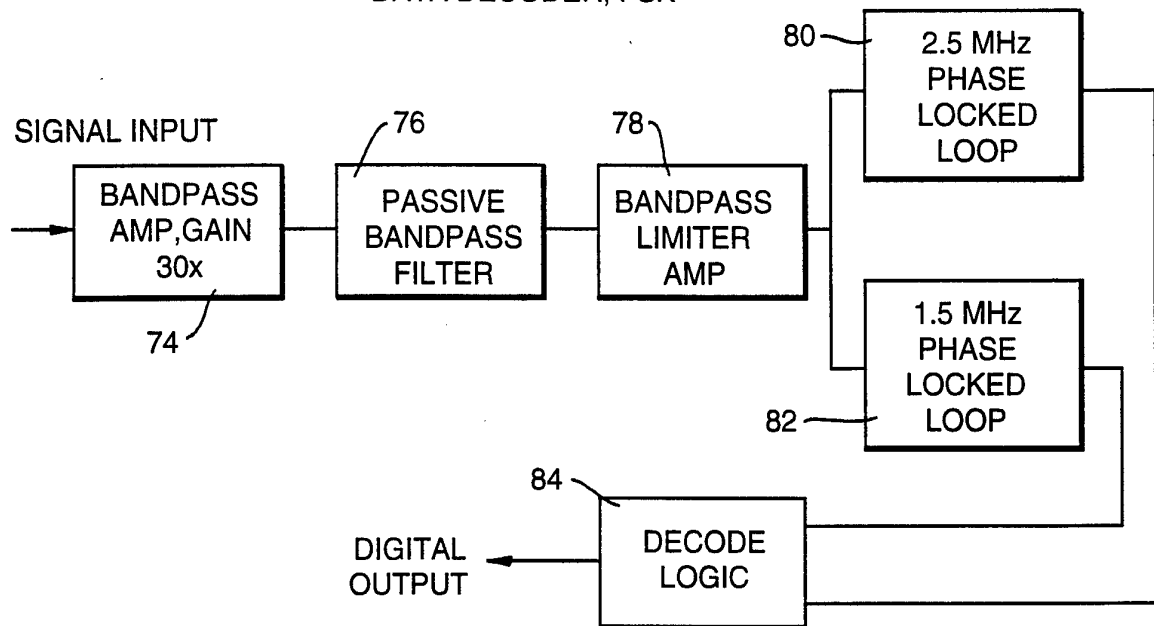

Fig.7A. SPLITTER / COMBINER, SIMPLE VERSION

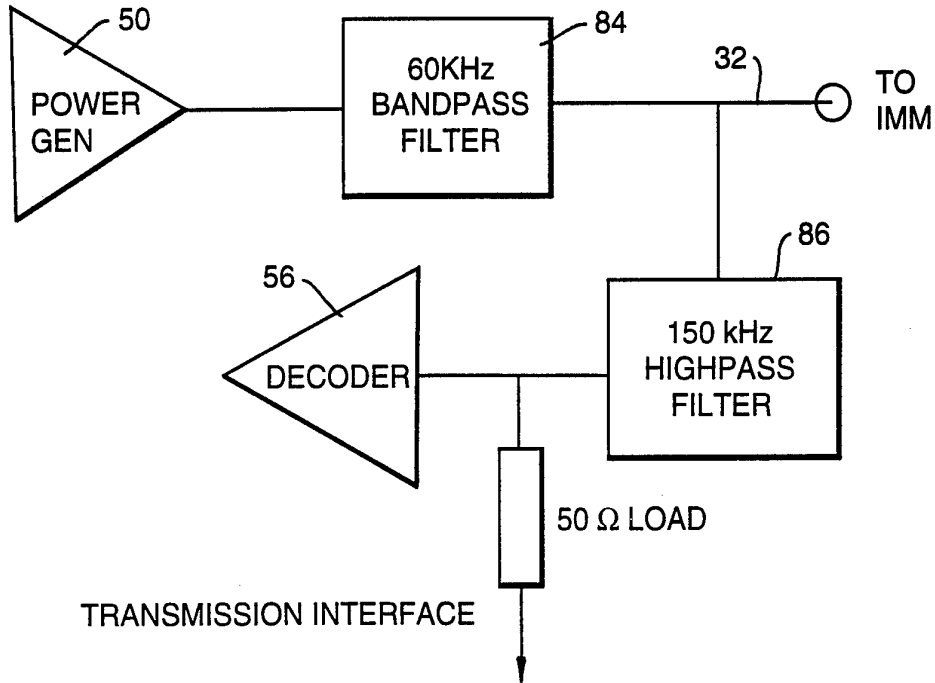
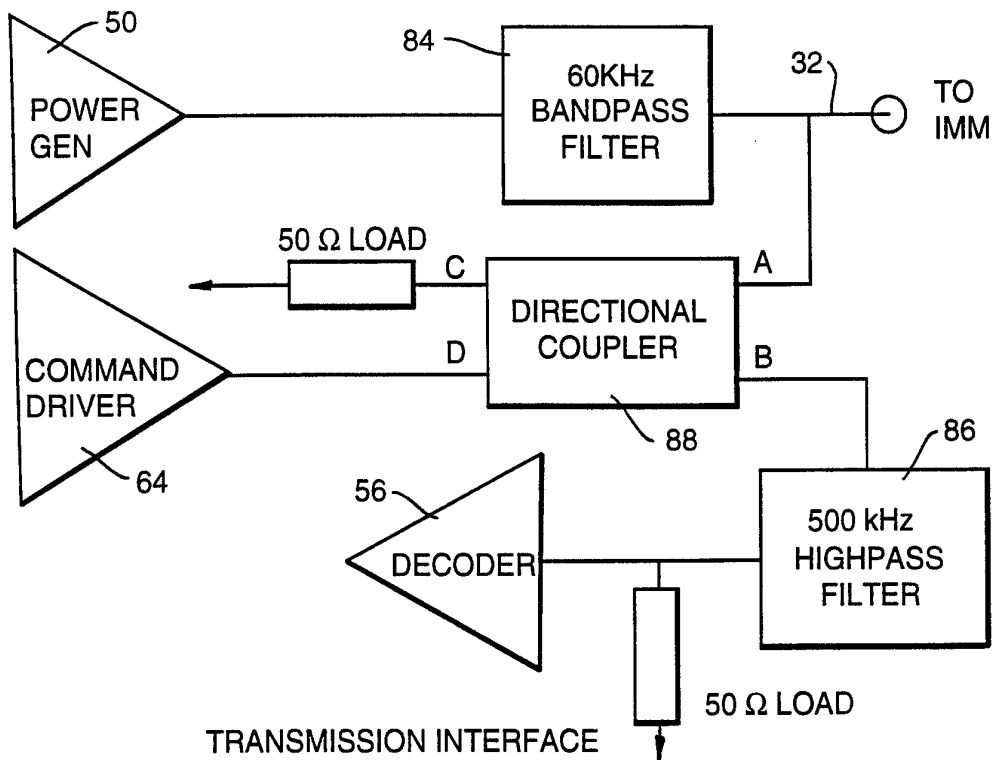

Fig.7B. SPLITTER / COMBINER, COMPLEX VERSION



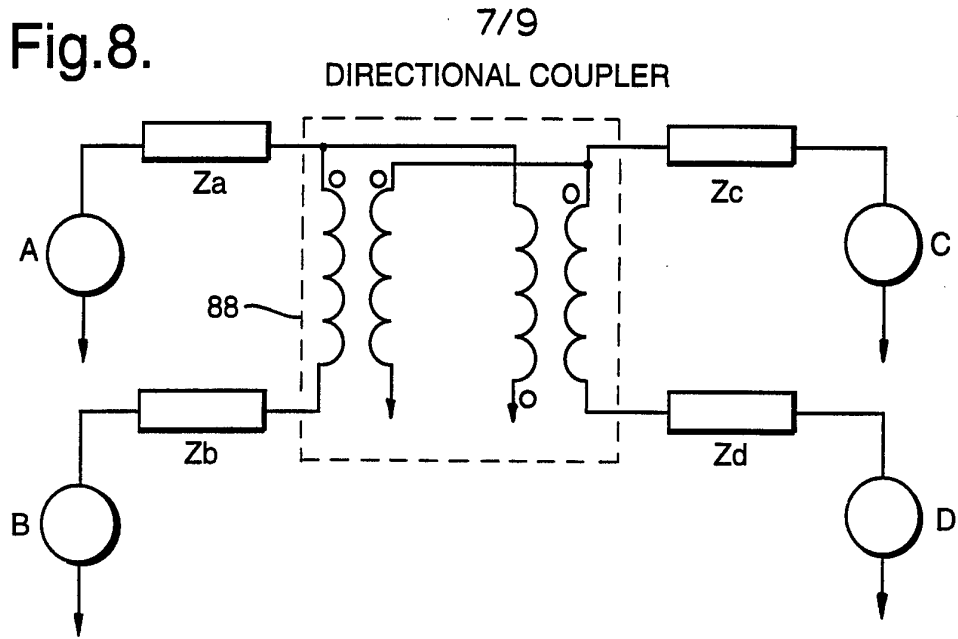

Fig.9.

AS LONG AS $Z_a/Z_b = Z_c/Z_d$ AND SOME SIMPLE RULES RELATING Z_a TO Z_b AND Z_a TO Z_c ARE USED TO DETERMINE THE TRANSFORMER RATIOS, THE FOLLOWING TABLE HOLDS TRUE:

INPUT	OUTPUT 1	OUTPUT 2	NULL
A	B	D	C
B	A	C	D
C	D	B	A
D	C	A	B

Fig.10.

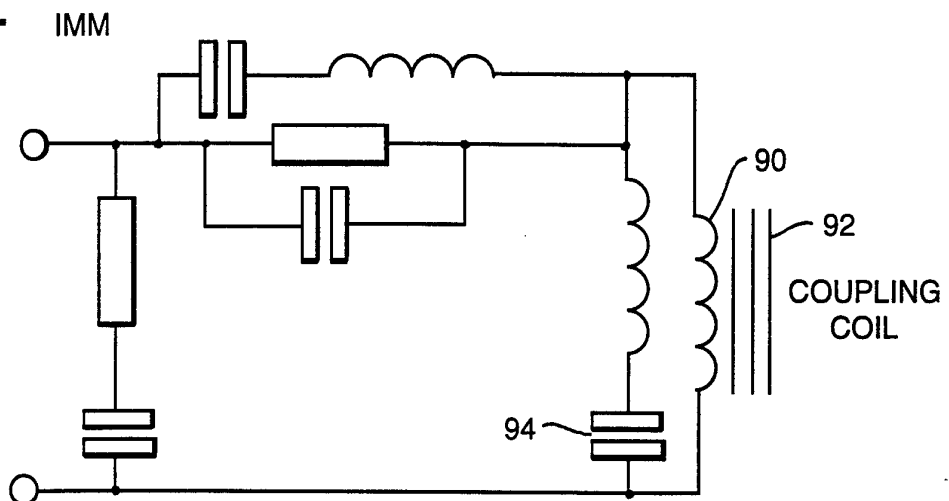

Fig.11.

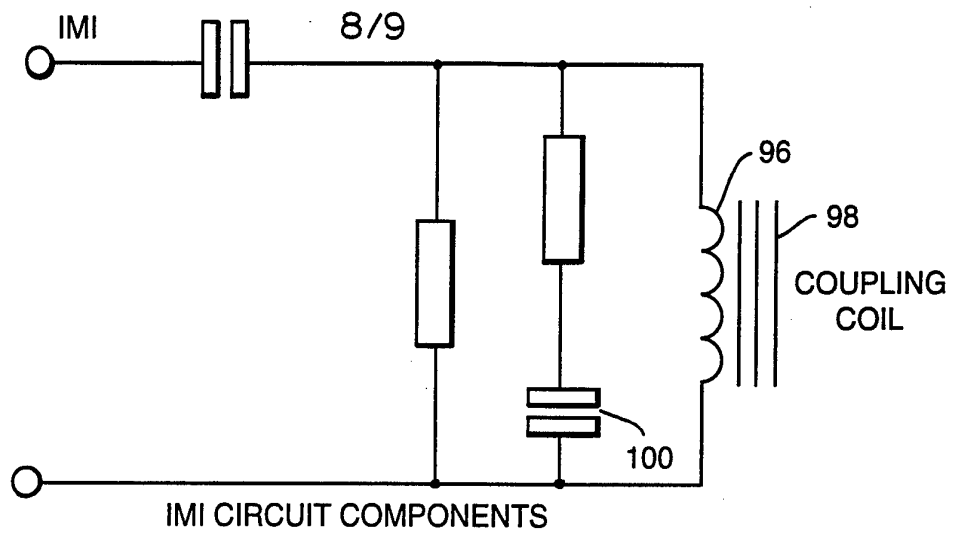
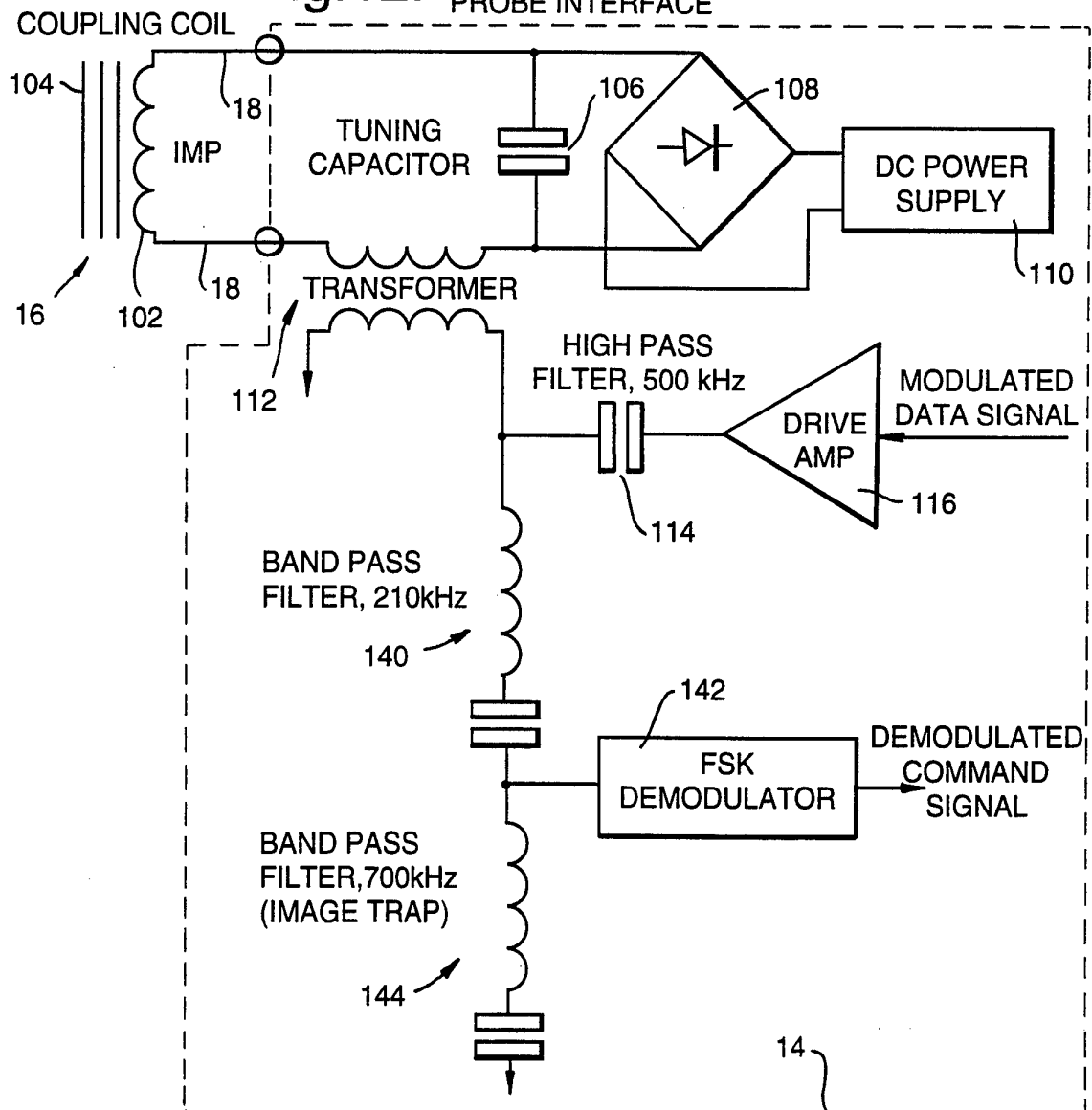
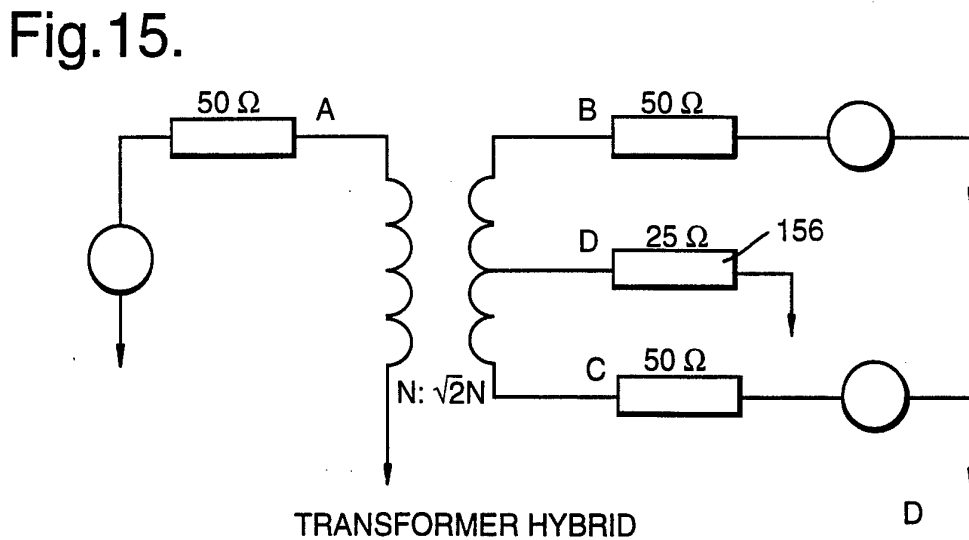
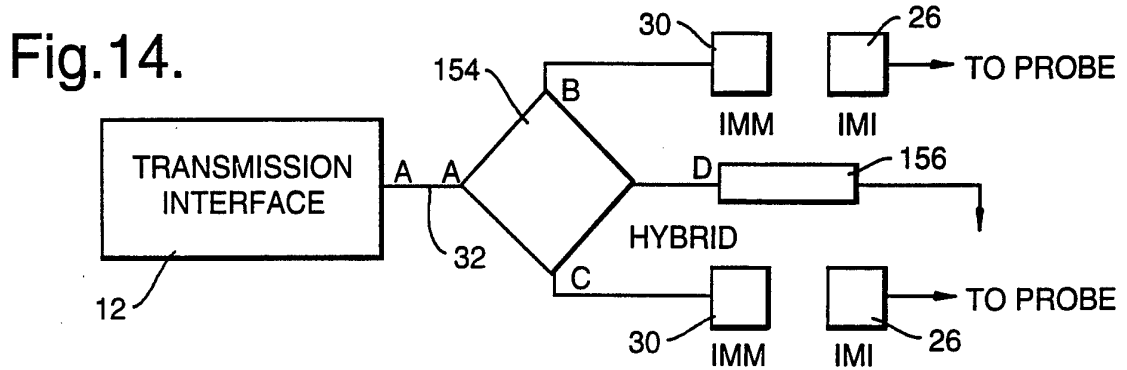
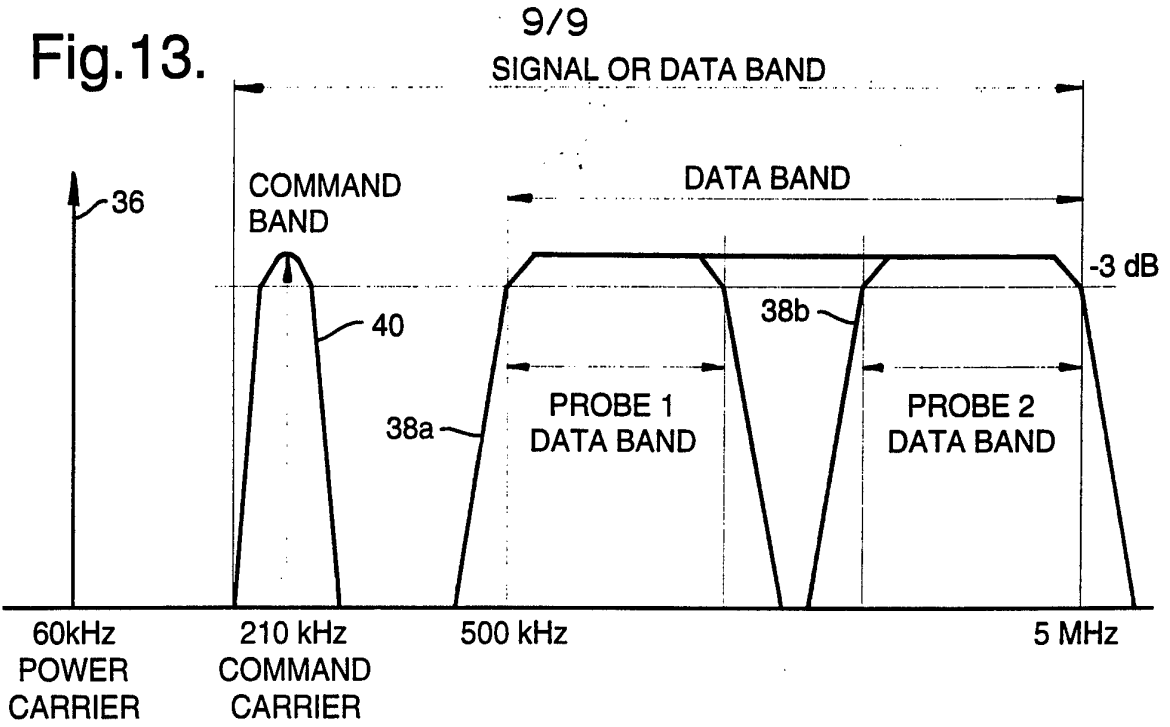

Fig.12. PROBE INTERFACE





INTERNATIONAL SEARCH REPORT

International Application No
PCT/GB 94/01962

A. CLASSIFICATION OF SUBJECT MATTER
IPC 6 G08C17/04 H04B5/00

According to International Patent Classification (IPC) or to both national classification and IPC

B. FIELDS SEARCHED

Minimum documentation searched (classification system followed by classification symbols)
IPC 6 G08C H04B

Documentation searched other than minimum documentation to the extent that such documents are included in the fields searched

Electronic data base consulted during the international search (name of data base and, where practical, search terms used)

C. DOCUMENTS CONSIDERED TO BE RELEVANT

Category *	Citation of document, with indication, where appropriate, of the relevant passages	Relevant to claim No.
X	GB,A,2 129 138 (SUGAR RESEARCH LIMITED) 10 May 1984	1-3,5,6
Y	see page 2, line 59 - page 3, line 85; figures 3,4	4
X	FR,A,2 440 042 (NORD-MICRO ELEKTRONIK FEINMECHANIK AG.) 23 May 1980 see page 7, line 29 - page 9, line 3; figure 3	1-3,5,6
Y	EP,A,0 457 306 (GAS-,ELEKTRIZITÄTS- UND WASSERWERKE KÖLN AG.) 21 November 1991 see page 6, column 10, line 13 - page 7, column 11, line 14; figures 7,8	4

Further documents are listed in the continuation of box C.

Patent family members are listed in annex.

* Special categories of cited documents :

- *A* document defining the general state of the art which is not considered to be of particular relevance
- *E* earlier document but published on or after the international filing date
- *L* document which may throw doubts on priority claim(s) or which is cited to establish the publication date of another citation or other special reason (as specified)
- *O* document referring to an oral disclosure, use, exhibition or other means
- *P* document published prior to the international filing date but later than the priority date claimed

- *T* later document published after the international filing date or priority date and not in conflict with the application but cited to understand the principle or theory underlying the invention
- *X* document of particular relevance; the claimed invention cannot be considered novel or cannot be considered to involve an inventive step when the document is taken alone
- *Y* document of particular relevance; the claimed invention cannot be considered to involve an inventive step when the document is combined with one or more other such documents, such combination being obvious to a person skilled in the art.
- *&* document member of the same patent family

Date of the actual completion of the international search

11 November 1994

Date of mailing of the international search report

24. 11. 94

Name and mailing address of the ISA

European Patent Office, P.B. 5818 Patentlaan 2
NL - 2280 HV Rijswijk
Tel. (+31-70) 340-2040, Tx. 31 651 epo nl,
Fax (+31-70) 340-3016

Authorized officer

Wanzeele, R

INTERNATIONAL SEARCH REPORT

Information on patent family members

International Application No

PCT/GB 94/01962

Patent document cited in search report	Publication date	Patent family member(s)	Publication date
GB-A-2129138	10-05-84	AU-A- 1999983	05-04-84
FR-A-2440042	23-05-80	DE-A- 2846583 GB-A, B 2037995	30-04-80 16-07-80
EP-A-0457306	21-11-91	DE-A- 4016010	21-11-91