



HU000030011T2

(19) **HU**(11) Lajstromszám: **E 030 011**(13) **T2****MAGYARORSZÁG**  
Szellemi Tulajdon Nemzeti Hivatala**EURÓPAI SZABADALOM**  
**SZÖVEGÉNEK FORDÍTÁSA**

(21) Magyar ügyszám: **E 09 750006** (51) Int. Cl.: **B62D 12/02** (2006.01)  
(22) A bejelentés napja: **2009. 05. 05.** **B60D 1/14** (2006.01)  
**B60D 11/55** (2006.01)  
**B60D 11/67** (2006.01)  
(96) Az európai bejelentés bejelentési száma: **B62D 47/02** (2006.01)  
**EP 20090750006** **B62D 59/04** (2006.01)  
(97) Az európai bejelentés közzétételi adatai: **G05D 1/02** (2006.01)  
**EP 2285644 A1** **2009. 11. 26.** **B62D 53/00** (2006.01)  
(97) Az európai szabadalom megadásának meghirdetési adatai: **B62D 47/00** (2006.01)  
**EP 2285644 B1** **2016. 05. 04.** **B60D 11/73** (2006.01)  
**B60D 1/52** (2006.01)

(86) A nemzetközi (PCT) bejelentési szám:  
**PCT/FR 09/000526**(87) A nemzetközi közzétételi szám:  
**WO 09141525**

(30) Elsőbbségi adatok: <b>0802522</b> <b>2008. 05. 06.</b> <b>FR</b>	(73) Jogosult(ak): <b>Lohr Electromecanique, 67980 Hangenbieten (FR)</b>
(72) Feltaláló(k): <b>ANDRE, Jean-Luc, F-67120 Molsheim (FR)</b>	(74) Képviselő: <b>SBGK Szabadalmi Ügyvivői Iroda, Budapest</b>

(54) **Közúti szerelvény két egymás utáni közúti modulja közötti szétkapcsolható csuklós kötés**

Az európai szabadalom ellen, megadásának az Európai Szabadalmi Közlönyben való meghirdetésétől számított kilenc hónapon belül, felszólalást lehet benyújtani az Európai Szabadalmi Hivatalnál. (Európai Szabadalmi Egyezmény 99. cikk(1))

A fordítást a szabadalmat az 1995. évi XXXIII. törvény 84/H. §-a szerint nyújtotta be. A fordítás tartalmi helyességét a Szellemi Tulajdon Nemzeti Hivatala nem vizsgálta.

The present invention relates to a disconnectable articulated connection between two successive motorized road modules for forming a road train which consists of a plurality of motorized road modules articulated so as to be disconnectable one after the other, of the type described in WO 2007/132121 A1.

The present invention also relates to the road module that can be hitched and articulated on either end of and to similar vehicles in order to constitute a road train. It also relates to the road train formed in this way.

This disconnectable articulated connection is composed of coupling means provided on the leading road module in a series of two road modules and a hitching drawbar component carried on the front of the trailing road module. The drawbar component has an articulated rear extremity pivoting on a vertical axle on a pivot center that is independent from the adjacent axle or from the directional assembly of the trailing vehicle and a front extremity which is disconnectably coupled to the rear of the leading module, but fixed in direction relative to the leading module. These connections allow enough freedom for rolling and pitching so that motion can proceed in complete safety, as well as an angular directional limitation on the trailing module when needed.

There may be a servo connection between the drawbar and the directional control for the trailing modules or between the drawbar and the trailing module. This connection may be functionally formed as a setting of the course of the trailing module.

Since there is only one driver for the convoy, it is important that the dynamic comportment of this small train be as close as possible to that of an isolated module, particularly in light of the fact that the driver passes from single vehicle mode to group mode without any transition.

This mechanical inter-module connection must set the trajectory of the following vehicle and ensure that a minimum distance remains between the modules both in a straight line and when on curves, as well as holding the electric or pneumatic connectors or other connectors to be used.

The field of urban and inter-urban road vehicle passenger transportation is currently turning to solutions that utilize roadtrains formed as a series of several road modules which are independent modules when isolated, but which can be grouped into a series of road trains and then rapidly disconnected.

In several instances, such as the temporary use of road trains or separate vehicles, or when returning vehicles from one place to another such as mechanical breakdown, and other situations, it is always necessary to minimize the distance between modules in order to, among other things, make it impossible for people along the road, passers-by, cyclists, etc., to cross the convoy. Generally, for example, on small vehicles used for tourism purposes, there are unattractive chains located on either side of the drawbar that provide this security.

In the scope of the invention, it is not necessary to provide additional protection to fulfill this function.

The flexibility and modular nature of this public urban transportation form make it particularly attractive from all points of view to urban administrators seeking public transportation equipment.

Implementing this transportation technique poses immediately two important problems that must be resolved simultaneously. The first is the convenience, speed, and reliability of the articulated inter-modular connection and of its disconnection, and the second, the possibility for passengers to circulate between vehicles.

To resolve the first problem, it is necessary to use an adapted and quickly disconnectable articulated connector to guarantee that a minimum of space exists between modules at least when in a straight line, which is the object of the present invention defined in claim 1.

According to the present invention, the disconnectable connection is a hitching device, for example, a short hitch, comprising a drawbar component or traction bar that is fixed in direction relative to the longitudinal axis of the leading module. This articulated connection allows a quasi-monotrace course to be set for the following vehicles. This articulated connection is quickly disconnectable from the leading module and the drawbar component is supported by the trailing module at its front portion. In addition, this connection comprises all the electrical, pneumatic or other connections necessary to transmit control and safety data between the modules.

This solution also applies to smaller road vehicles for transporting only a few people or even one person where no passageway is required for circulating between modules and where the distance between modules also must be as small as possible for safety reasons. In this case as well, the trajectory of the trailing vehicles must also be controlled completely.

The invention also relates to a road module having the above characteristics and which can be hitched and articulated at either end to similar modules to form a road train. It also relates to the road train formed in this way.

Other features and advantages of the invention will become apparent from the following description provided by way of example and from the accompanying drawings, in which:

- Figure 1 is a plane view of several road modules interconnected by the mechanical connection that is the object of the invention in a straight line configuration;
- Figure 2 is a plane view of several road modules interconnected during a turn;
- Figure 3 is a schematic general profile view showing a series of three road modules articulated one after the other; and
- Figure 4 is a plane view of a road train formed of small modules.

The present invention relates not only to the articulated connection between two road modules, but also to the road module having the features described above and capable of being hitched and articulated to similar modules in order to constitute a road train, and to the road train thus formed.

The present invention according to claim 1 proceeds from the generally inventive concept that consists of providing, as an articulated disconnectable connection between two successive road modules, one a leading module 1 and one a trailing module 2 which constitute a road train 3 when connected, a disconnectable connection and orientation assembly 4 formed of two disconnectable portions. These two disconnectable portions are composed of rapid connecting and disconnecting means 5 and of a hitching device 6, for example, with a drawbar component 7 supported at the front of trailing road module 2 and directionally fixed relative to the median longitudinal axis of the leading road module.

Generally speaking, there is a connection and orientation assembly 4 that is disconnectable, which in a straight line procures an inter-modular space 8 of shortened length.

According to the invention, the drawbar component 7 terminates on one side beneath the trailing module 2 under the front part of this module under which it is pivotably mounted by its rear extremity 9 in median longitudinal position near the axis of the front axle. The drawbar component 7

terminates on the other side with a front extremity 10 having complementary connection and disconnection means 5 preferably of rapid type.

5 Rapid coupling and uncoupling elements or disconnectable attachments or any other means may be used to separate and rejoin the two portions of the hitching device.

These elements may be associated with automatic locking and unlocking devices as well as with auto-centering devices.

Preferably, the drawbar component is situated in the occupied ground space perimeter of each trailing module 2.

10 Depending upon the application, this disconnectable articulated connection is designed so that the free space existing between successive modules is as short as possible.

As indicated, there may be a disconnectable short hitching device.

15 For the description, it is considered that a road train is formed of a plurality of modules, for example, identical modules, and that the modules of each pair of two successive road modules are joined in the same articulated and disconnectable manner. This supports the presumption that the following description is complete if it refers to a single disconnectable articulated connection with all its variations.

20 Therefore, the following description will deal with only two successive road modules, one upstream and one downstream, respectively termed the leading module 1 and the trailing module 2 of a road train comprised of a plurality of road modules that are similar or identical to one another, and identical or similar to those shown in the drawings and used as examples.

25 Each motorized road module of a pair of two successive road modules 1 and 2 comprises a rear face surface 12 and a front face surface 13 equipped to be able to realize the connection and to articulate with each other.

30 The essential point is the ability to constitute the disconnectable articulated connection between two successive modules using a connector compatible with maintaining a short distance between modules in a straight line configuration.

35 At the base of the rear face surface 12 of leading module 1 the rapid coupling and uncoupling means 11 are situated, preferably with automatic locking and unlocking and auto-centering capabilities for a hitching assembly whose drawbar component 7 ensures the disconnectable articulated mechanical connection with the trailing module 2.

There may be a total traction connection, but also a partial traction connection, that is, a connection through which only small traction forces pass because trailing module 2 retains and puts to work its drive power or a portion of it which is automatically regulated for total or partial use. As there is only one driver to conduct the train, the connections required to control traction and braking pass through cables integrated with the connection which are automatically connected when hitched.

This drawbar component may be a triangular, T-shaped or I-shaped mechanical assembly, or a simple traction bar. The drawbar of the short hitching assembly may be made differently using various current techniques.

Drawbar component 7 has a front extremity that attaches automatically, locks, auto-centers, and is detachable with the rapid coupling and uncoupling means that exist at the rear of leading module 1 in order to ensure that the drawbar component has a fixed orientation in the direction of the longitudinal axis of leading module 1.

Drawbar component 7 terminates on the downstream side in a rear extremity that is pivotably mounted or serves as a pivoting articulation cooperating with a pivot center independent of the steering axle or the directional assembly of trailing road module 2, or is pivotably mounted on the module chassis. The location of this articulation is selected so as to permit the trailing vehicles to travel in a quasi-monotrace trajectory.

Obviously, some play and a degree of freedom to pivot on the pitch axle and the roll axle are necessary to absorb variations in the shape of the road and displacement associated with travel.

Preferably, drawbar component 7 is supported by the trailing road module 2. It is located at a low level, retracted below the front face surface 13 so as not to project from the front of trailing module 2 for mechanical protection purposes, but also for esthetics.

Conversely, and also preferably but not necessarily, the connection and disconnection means supported by the rear portion of leading module 1 are located on the lower portion projecting from the rear face surface 12 of leading module 1 facing each other and mechanically protected by a projecting edge 15.

This projecting edge 15, easily visible in Figure 3, may have a flat upper surface serving as a floor platform 16 for passenger level passageway,

known as intercommunicating gangway, between the two modules, its width defining the depth of the inter-modular space.

5 The upper portion of this platform 16 or that of a thickness top layer, an upward extension or other equivalent, is essentially level with the floors of the road modules on either side.

To keep the intermediate space 8 between the modules as short as possible, in a preferred version, it is necessary that while still allowing all the usual turning angles, the facing surface shapes of successive road modules must be disengaging and non interfering.

10 For this reason, curved shapes like the ones shown are desirable but not necessary; it is also conceivable to use curved or straight shapes on the rear of the vehicle to form a barrier preventing any intrusion between the modules.

15 More specifically, it is preferable to adopt circular shapes, particularly those with a center that is also the pivot center for drawbar component 7.

20 As seen in Figures 1, 2 and 3, the embodiment shown by way of example, with curved front and rear face surfaces 13 and 12 on the road modules, considerably reduces inter-modular depth and thus the width of platform 16 which serves in one embodiment as a support for an intercommunicating gangway for passengers.

To ensure planar continuity between the coupling means and the drawbar component 7, the two portions of the disconnectable articulated inter-module connection are located at the same level.

25 On one end, drawbar component 7 is placed at a low level below the carriage of trailing road module 2, preferably retracted and not projecting from the front face surface 13; on the other end, the coupling and uncoupling elements are located facing the corresponding extremity of the drawbar component 7.

30 As indicated, these coupling and uncoupling elements may be located at the end of a projection 15 with a flat upper portion forming a platform 16 at the base of the rear of leading module 1, which platform is located at the same level as the floor of two successive road modules and serves as a floor support for the intercommunicating gangway on the road module embodiment that offers communication.

35

The width of platform 16 therefore represents at most the width of the space between the facing surfaces of the road modules.

5 There is a supplemental means to recall the drawbar component into its longitudinal position so as to prevent finding a trailing module with an oblique drawbar component after uncoupling if this process occurs on a curve. This recall feature in the vehicle axis is also necessary for ease in coupling the modules.

10 Angular blocks also exist to limit the drawbar component's angle of orientation, preventing the occurrence of dangerous orientation, particularly during maneuvers.

This can be accomplished by using either physical blocks or virtual blocks.

15 Finally, in order to diminish directional forces in the drawbar component, there may be means for assisting front wheel orientation of trailing module 2.

The present invention also relates to the road module having the features described above and capable of being hitched and articulated to similar modules to constitute a road train, and to the road train formed in this way.

20 Thus, among other things, it comprises the disconnectable connection and orientation assembly with a hitching device 6, for example, the drawbar component 7, and the coupling and uncoupling elements with locking and unlocking capability; and as a variation, the projecting edge 15 with upper platform 16.

KÖZÚTI SZERELVÉNY KÉT EGYMÁS UTÁNI KÖZÚTI MODULJA KÖZÖTTI  
SZÉTKAPCSOLHATÓ CSUKLÓS KÖTÉS

## SZABADALMI IGÉNYPONTOK

1. Szétkapcsolható csuklós kötés közúti szerelvény két egymás utáni közúti modulja között, amely szerelvényt több, egymás utáni motoros közúti modul képezi, amelyek közül legalább egy közúti vezetőmodul (1) és egy közúti kísérőmodul (2) mindegyikének az elején van egy vezetőtengelye, amely kötés magában foglal

- egy szétkapcsolható összekötő és iránybaállító egységet (4), amely magában foglal egy összekapcsoló elemet (6), valamint a gyors összekapcsolást és szétkapcsolást szolgáló eszközöket (5), és úgy, hogy

- az összekapcsoló elem (6) egy rúdrész (7), amelyet a kísérőmodul (2) hordoz az elülső része alatt, és annak alvázához képest elforgathatóan van szerelve, annak vezetőtengelyétől függetlenül forog, valamint irányultsága a vezetőmodul (1) hossz tengelyéhez képest állandó, a rúdrész (7) hátsó végénél fogva elforgathatóan van szerelve a kísérőmodul alvázának eleje alatt hosszanti középhelyzetben annak vezetőtengelyének mértani tengelye közelében,

- az összekapcsolást és szétkapcsolást szolgáló eszközök egyenként két, egymással komplementer részből vannak kialakítva, amelyek közül az egyik az egyes modulok hátulján van elhelyezve, a másik pedig a rúdrész (7) elülső végén van elhelyezve, amely a csuklós kötés szétkapcsolható részét alkotja, a rúdrész (7) többi részét a kísérőmodul hordozza a szétkapcsolás után,

és hogy a szétkapcsolható kötésnek vannak

- billegő és bólintó kitérésre alkalmas eszközei az elfordulás középpontjának szintjén, és

- szögletes ütköző eszközei.

2. Az 1. igénypont szerinti csuklós kötés, azzal jellemezve, hogy a rúdrész (7) egy teleszkópos rúd.

3. Az előző igénypontok bármelyike szerinti csuklós kötés, azzal jellemezve, hogy a vezetőmodul (1) és a kísérőmodul (2) között lévő tér olyan kicsire van csökkentve, hogy egy arra járó nem tud átmenni a modulok között.

4. Az 1. igénypont szerinti csuklós kötés, azzal jellemezve, hogy a rúdrész (7) a kísérőmodul (2) elülső alsó részén van rögzítve.

5. Az 1. igénypont szerinti csuklós kötés, azzal jellemezve, hogy a rúdrész (7) a kísérőmodul (2) elején végződik, és azzal, hogy a vezetőmodul (1) és a kísérőmodul (2)

közötti csuklós kötés szemközti megfelelő része a vezetőmodulon (1) egy, a vezetőmodul (1) alsó hátulsó részéből kiálló rész (15).

6. Az előző igénypont szerinti csuklós kötés, azzal jellemezve, hogy a kiálló résznek (15) van egy sík felső része plató (16) formájában, amelynek a felső része nagyjából ugyanazon a szinten helyezkedik el, mint az összes egymás utáni közötti modul padlója, hogy a modulok közötti átjáráshoz padlóként szolgáljon.

7. Az 1. igénypont szerinti csuklós kötés, azzal jellemezve, hogy a rúdrész (7) és az összekapcsolást és szétkapcsolást szolgáló eszközök (5) közös síkban folytatódnak.

8. Az 1. igénypont szerinti csuklós kötés, azzal jellemezve, hogy a rúdrész (7) elülső vége hátrább van, mint a kísérmódul (2) elülső homlokoldala (13).

9. Az 1. igénypont szerinti csuklós kötés, visszatérítő eszközökkel jellemezve, amelyek a rúdrész (7) központi részén helyezkednek el.

10. Az 1. igénypont szerinti csuklós kötés, azzal jellemezve, hogy a csuklós kötésnek mindkét oldalon van egy szögletes ütközője a jobbra és a balra forduláshoz.

11. Az 1. igénypont szerinti csuklós kötés, olyan eszközökkel jellemezve, amelyek a kísérmódul (2) első kerekeinek irányítottóságát a rúdrész (7) irányítottóságától függően segítik.

(A meghatalmazott)

Magyarországi Szociális Munka Minisztérium  
Szociális Igazgatóság  
SZOK Szociális Ügyviteli Iroda  
H-1067 Budapest, Andrássy út 113.  
Telefon: +36 1 266 7770 Fax: +36 1 266 7771  
Email: szok@szok.gov.hu

FIG.1

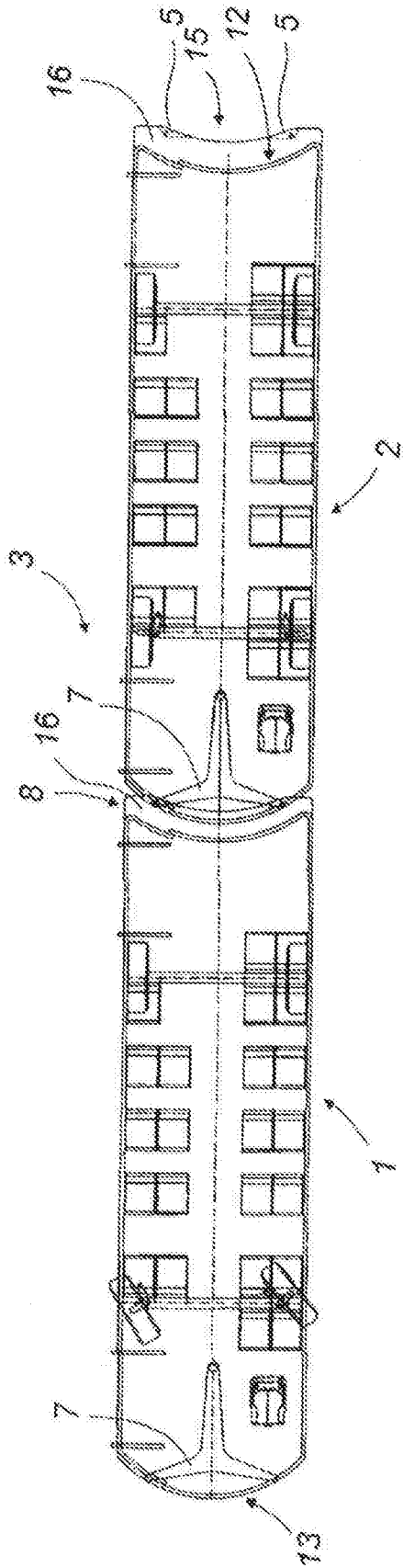

FIG.3

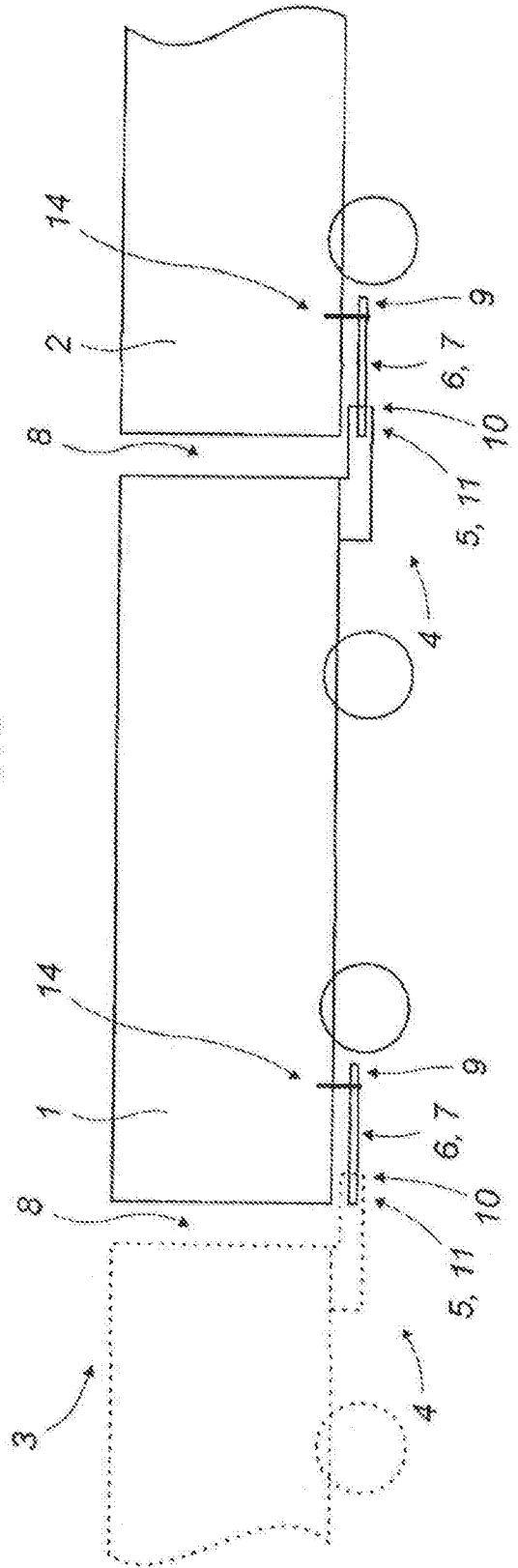

FIG.2

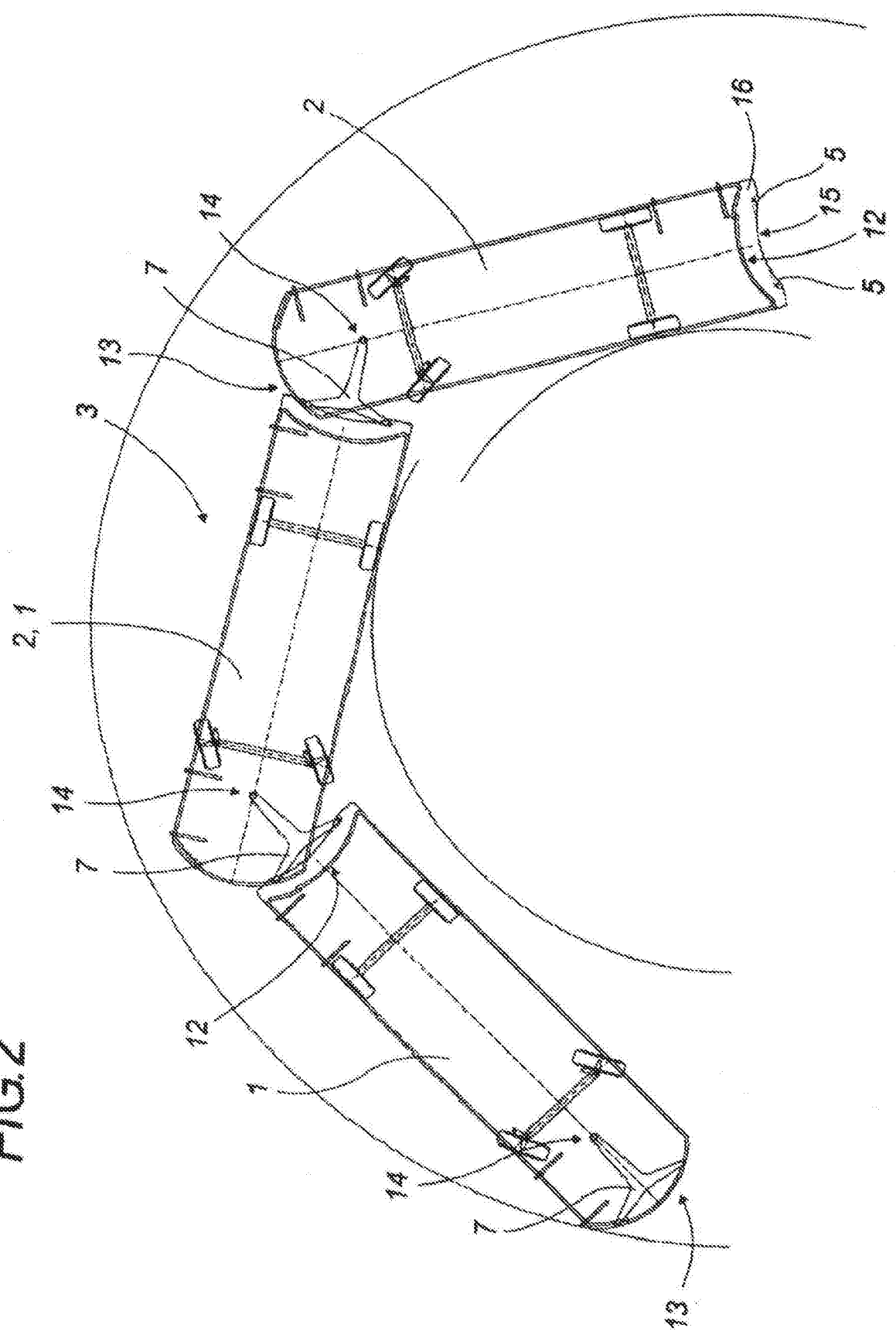

FIG.4

