

June 26, 1962

W. G. BROERS

3,040,342

CRIB MOTIVATOR

Filed June 29, 1959

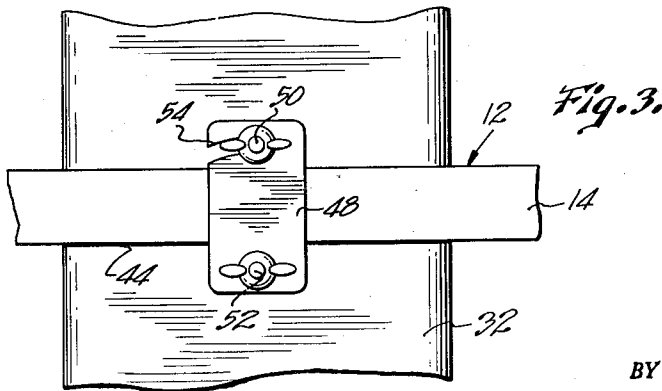
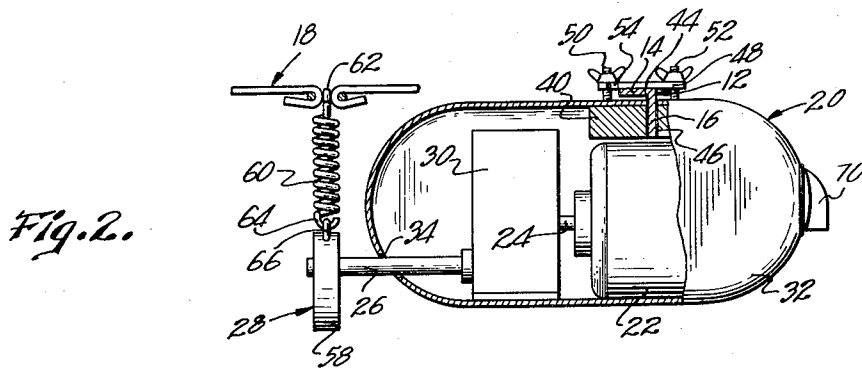
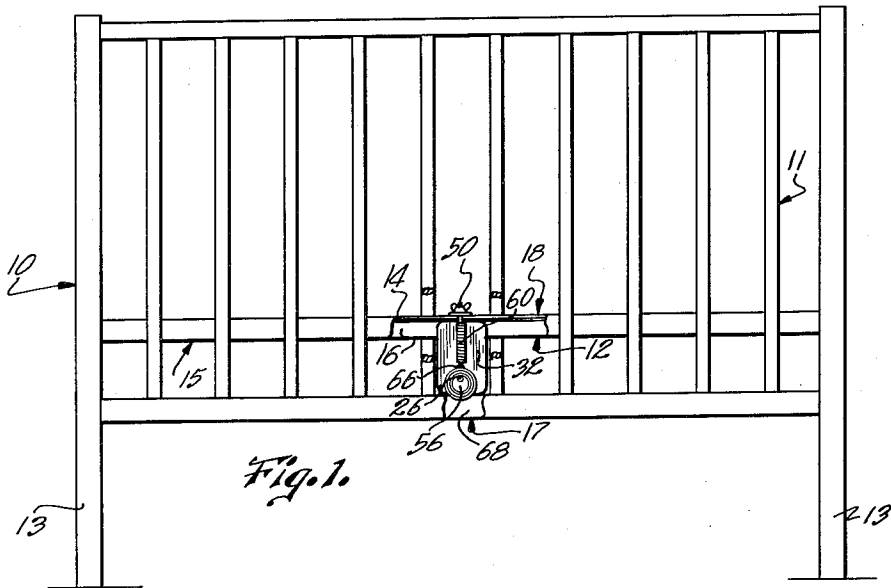

INVENTOR.
Wiley G. Broers

BY

Stoney, Schmidt, Johnson & Stoney
ATTORNEYS.

1

3,040,342
CRIB MOTIVATOR
Wiley G. Broers, Rte. 2, Wellsville, Kans.
Filed June 29, 1959, Ser. No. 823,408
1 Claim. (Cl. 5-109)

This invention relates to a motivator for baby beds and more specifically, to a device adapted to be releasably attached to the frame of a baby bed springs and coupled with such springs in a manner to impart a gentle vibrating motion to the springs and, therefore, to the mattress carried thereby, all for the purpose of "rocking" the baby to sleep.

It is the most important object of the present invention to provide a unitary attachment that includes as a part thereof, an eccentric, together with a coil spring which joins the eccentric to the bed springs whereby the motivation is gentle, yet sufficient for the purposes desired.

Still another important object of the present invention is to provide quickly detachable means for connecting the unit to one rail of the springs, rendering the entire unit universally adapted for use with varying types of beds or cribs.

In the drawing:

FIG. 1 is a side elevational view of a baby bed showing the motivator of the instant invention mounted thereon, parts of the bed being broken away for clearness.

FIG. 2 is an enlarged, fragmentary, side elevational view partially in section illustrating the motivator attached to the springs and operably coupled therewith; and

FIG. 3 is an enlarged, fragmentary top view showing the releasable means of attachment to the frame of the springs.

Baby bed 10 chosen for illustrating the principles of the instant invention, is quite conventional in that it includes a frame having sides and ends interconnecting four legs. Sides 11 and 17 and two legs 13 are shown in FIG. 1, it being understood that side 17 is normally adapted to be raised and lowered. Yieldable wire grid means 18 are usually carried by the four legs and include side rails 12 and 15 that are transversely L-shaped. As shown in FIGS. 1 and 2, rail 12 has a top plate 14 provided with a depending flange 16.

The improvements forming the subject matter of the instant invention embody a unitary attachment broadly designated by the numeral 20, including an electric motor 22 having a drive shaft 24, a driven shaft 26 provided with an eccentric 28, and gear reduction means 30 operably interconnecting shafts 24 and 26. The motor 22 and the gear reduction means 30 are housed within a case 32, and an opening 34 within one wall of the case 32, clears the shaft 26.

The attachment 20 is carried by the rail 12 therebeneath and, to this end, a block 40 may be provided in the case 32.

Clearance slots 44 and 46 for the flange 16 are provided in the case 32 and the block 40 respectively, and a strap 48 overlies the plate 14. Strap 48 is connected to the block 40 by bolt and nut means 50 and 52, the latter of which serves as a pivot pin, allowing swinging of the strap 48 to a position permitting removal of the attachment 20 from the rail 12. A slot 54 in the strap 48 clears the bolt and nut means 50 when the latter is loosened so that strap 48 can be swung as aforementioned.

The eccentric 28 includes a disc 56 keyed or otherwise attached eccentrically to the shaft 26 and a band 58 surrounding the disc 56, it being understood that band 58 is adapted to work freely around the disc 56.

A coil spring 60 provided with end loops 62 and 64,

2

releasably interconnect the wire grid 18 and the band 58, it being noted that spring 60 depends from the springs 18 and that the lowermost loop 64 is hooked through an eye 66 on the outer face of band 58.

It is apparent that during continuous operation of electric motor 22 to drive its shaft 24, rotative motion is imparted to the driven shaft 26 through the gear reduction means 30. Shaft 26 in turn imparts rotative movement to the disc 56 which works the band 58, thereby transmitting reciprocable motion in a vertical direction to the spring 60. The up and down movement of the spring 60 is in turn transmitted to the grid 18, thereby gently motivating the latter, as well as the mattress (not shown) carried by the grid 18. It follows that a gentle vibratory motion is felt by the child on the mattress, tending to lull him to sleep or otherwise pacify the child in a manner not unlike rocking or merely shaking the bed 10 for such purposes.

Note in FIG. 1 that the case 32 is interposed between rail 12 and the lower beam 68 of side 17, permitting the aforementioned raising and lowering of side 17.

It is now seen that I have provided a small, compact device for gently bouncing baby beds which can be easily and quickly attached to all standard baby crib springs. It consists essentially of the electric motor 22 and the reduction gears 30 fitted into case 32, having the slot 44 in the top thereof into which the angle iron 12 of grid 18 fits. Clamp 48 over the top 14 of the angle iron 12 holds the device secure.

Either a single electric switch or a variable speed switch 70 may be provided. An electric cord to fit any 110 volt outlet will also be obviously provided.

Aside from the above, the unit includes eccentric 28 having eye 66 receiving coil spring 60, the latter of which is hooked to bed springs 18 at any convenient point.

Having thus described the invention what is claimed as new and desired to be secured by Letters Patent is:

In combination, a baby bed; mattress-supporting, yieldable wire grid means carried by said bed and provided with a frame having a pair of spaced side rails thereon; a housing; means for mounting said housing on said frame below said grid means, said mounting means including a slotted block carried by the housing and disposed for receiving one of said side rails in the slot thereof, and a strap swingably carried on said block and disposed to overlie said one side rail when the latter is disposed within said slot to thereby suspend the housing from said one side rail; motivator means in said housing and including a motor having a drive shaft; a driven shaft carried by said housing and projecting outwardly therefrom, said driven shaft having an eccentric thereon adjacent the outermost end thereof; gear reduction means within the housing for interconnecting said drive and driven shafts; and means coupling said eccentric to said grid means, said coupling means including a band loosely surrounding the eccentric, and a coil spring carried by the band and secured to the grid means thereabove, whereby said grid means reciprocates vertically as said eccentric is rotated under the influence of said driven shaft and said drive shaft when said motor is energized.

References Cited in the file of this patent

UNITED STATES PATENTS

1,476,146	Cappabianca	Dec. 4, 1923
2,599,723	Row	June 10, 1952
2,677,135	Gourley	May 4, 1954
2,689,355	De Frank	Sept. 21, 1954
2,765,478	Pinto	Oct. 9, 1956
2,845,635	Eyer	Aug. 5, 1958

FOREIGN PATENTS

304,754	Italy	Jan. 17, 1933
---------	-------	---------------