

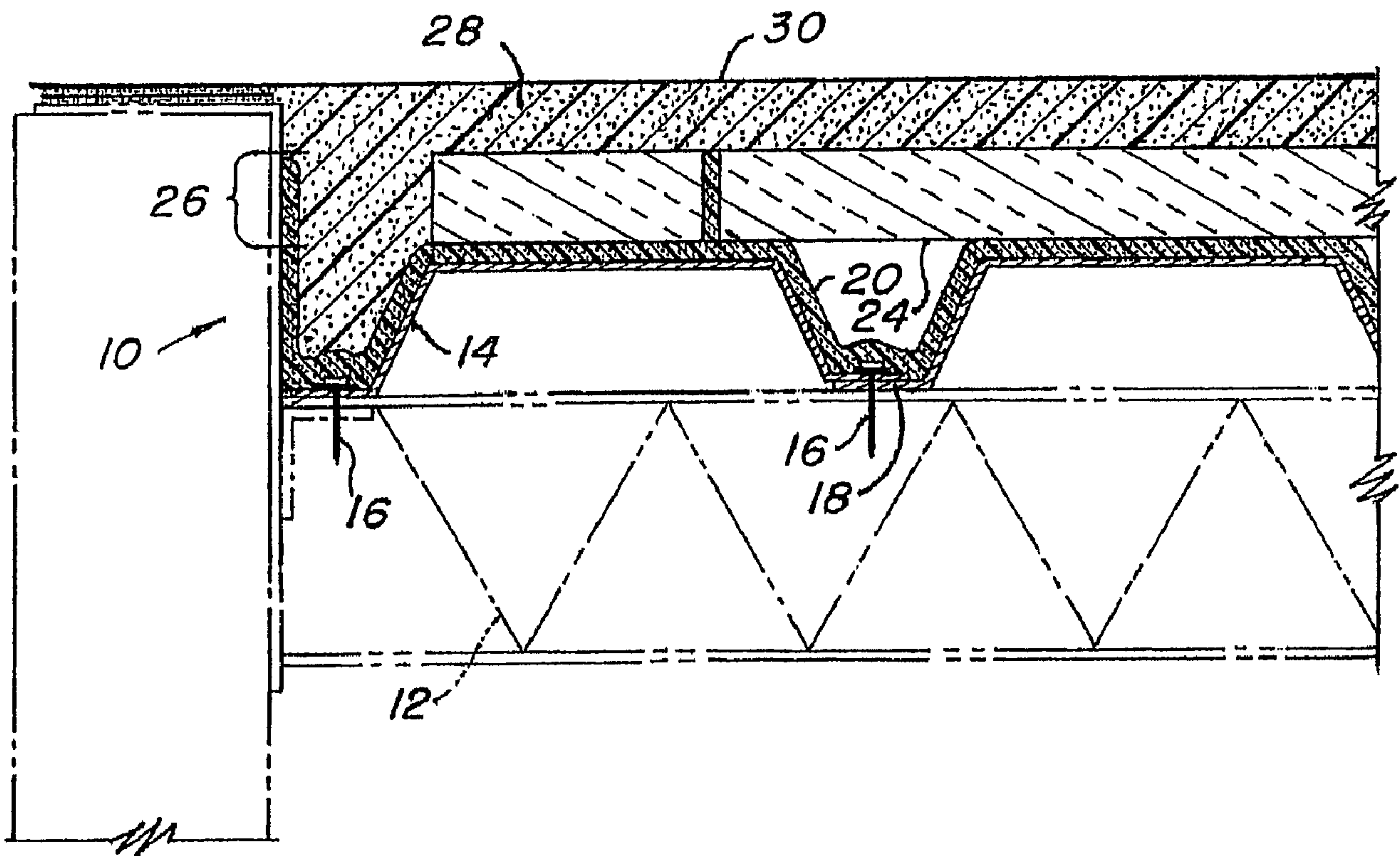

(22) Date de dépôt/Filing Date: 2008/03/27  
(41) Mise à la disp. pub./Open to Public Insp.: 2008/09/29  
(30) Priorité/Priority: 2007/03/29 (US11/693,224)

(51) Cl.Int./Int.Cl. *E04D 11/02* (2006.01)  
(71) Demandeur/Applicant:  
KELLY, THOMAS L., US  
(72) Inventeur/Inventor:  
KELLY, THOMAS L., US  
(74) Agent: OGILVY RENAULT LLP/S.E.N.C.R.L.,S.R.L.

(54) Titre : CHARPENTE DE TOITURE ET CONSTITUTION  
(54) Title: ROOF STRUCTURE AND METHOD FOR MAKING THE SAME



(57) Abrégé/Abstract:

Disclosed herein is a roof system including a roof deck, a previously existing roofing assembly upwardly adjacent to the roof deck, a foam material upwardly adjacent and in air sealing contact with the roofing assembly, a layer of reinforcing mesh embedded in the foam material, and a waterproof membrane upwardly adjacent of the foam material.

ABSTRACT

Disclosed herein is a roof system including a roof deck, a previously existing roofing assembly upwardly adjacent to the roof deck, a foam material upwardly adjacent and in air sealing contact with the roofing assembly, a layer of reinforcing mesh embedded in the foam material, and a waterproof membrane upwardly adjacent of the foam material.

## ROOF STRUCTURE AND METHOD FOR MAKING THE SAME

## BACKGROUND

Roof structures have been made for millennia ranging from simple lean-to thatched arrangements to more modern buildings having multiple layers of roofing materials, fire barriers, vapor barriers, air retarders, rigid roof insulations, cover boards, slipsheets and waterproofing membranes all designed to work together to keep the elements away from occupants of the building. Roof structures continue to be improved because each of the systems currently available has drawbacks and improvements are therefore desirable. Typical problems with roof structures center around wind uplift resistance and energy efficiency with insulations for heat and cold resistance to maintain internal building temperature as well as time and effort required to install the roof system.

## SUMMARY

Disclosed herein is a roof system including a roof deck, a previously existing roofing assembly upwardly adjacent to the roof deck, a foam material upwardly adjacent and in air sealing contact with the roofing assembly, a layer of reinforcing mesh embedded in the foam material, and a waterproof membrane upwardly adjacent of the foam material.

Also disclosed is a method for creating a roof system comprising:

air sealing a previously existing roofing assembly with a foam material and embedding a reinforcing mesh within the foam material.

## BRIEF DESCRIPTION OF THE DRAWINGS

Referring now to the drawings wherein like elements are numbered alike in the several Figures:

Figure 1 is a cross-sectional elevation view of the subject roof system;

5 Figure 2 is a cross-sectional elevation view of the similar roof system to that of Figure 1 however including a reinforcing mesh in a first position;

Figure 3 is a cross-sectional elevation view of another alternate embodiment roof system with the reinforcing mesh in a second position;

10 Figure 4 is a cross-sectional elevation view of a roof system intended for a metal building;

Figure 5 is a cross-sectional elevation view of a roof system similar to that of Figure 4 and the reinforcing material applied thereto; and

Figure 6 is a cross-sectional elevation of a roof system built upon an existing roof assembly.

## 15 DETAILED DESCRIPTION

Referring to Figure 1 an embodiment of the roof system 10 as disclosed and claimed herein is supported by an underlying building having joists or purlins 12. The roof deck 14 which may be a metal corrugated roof decking material is fastened to the underlying support structure 12 by conventional means such as fasteners 16. As corrugated metal  
20 decking 14 or any other modular decking material has a certain size and shape it is clear that there will be joints or overlap sections of the material. In Figure 1 there is an overlap section identified as an overlap flute area 18. Such overlap flute areas present an opportunity for easy entry of air from the building being roofed if such flutes are not sealed. Abutting edges of plywood or other material roofs create the same problem and can be resolved in the same  
25 manner as discussed hereunder.

In the embodiment of Figure 1, the roof decking material 14 is thinly but relatively uniformly covered by a foam 20 which may be a polyurethane foam or polyurea compound or other material having similar properties and combinations of materials including at least one of the foregoing materials and may be a slow curing foam or a fast curing foam depending upon functionality desired by the installer. As illustrated in Figure 1, foam 20 is a slow rise, slow cure polyurethane type foam which is desirable in this case because it allows adherence of the insulation board 24 to the uncured newly sprayed foam 20. During application of the foam 20 an installer will, in accordance with this disclosure, pay particular attention to covering overlap flutes 18 and any fastener 16 or other penetrations through the roof deck 14. The purpose of such concentration is to ensure that deck 14 is sealed against air movement therethrough. Following application of the foam 20, a plurality of insulation boards 24 are applied to the uncured foam 20 to be adhered thereto without the use of any mechanical fasteners which might otherwise provide a thermal bridge through the insulation layer. Also notable is that this disclosure teaches one of ordinary skill in the art to place in the insulation layer 24 spaced from a through roof penetration or roof perimeter location creating a space 26 that will subsequently be filled with foam to create a positive air seal and the thickness of the foam also acting as insulation. Following the application of the insulation layer 24 another layer of foam 28 is applied over the insulation layer and around the insulation layer at penetrations or a roof perimeter location. This material may be fast or slow rise material but in general fast rise material will be utilized at this stage of the roof construction since it cures rapidly and allows workers to walk thereon very quickly. Since there is no need to adhere any roof components to this foam material prior to the curing of material 28 there is no need to use slow rise foam. In general about an inch of foam is applied above the insulation boards 24 to provide a uniform top surface having a horizontal or inclined property as desired.

At this point in the creation of the roof system, this roof will be waterproof and may act as a temporary roofing system prior to insulation of the waterproofing membrane which will be the permanent roof waterproofing component. This is beneficial in that workers may utilize the roof for walking without damaging the relatively fragile waterproofing membrane that will be installed later. One example of a membrane is EPDM.

The membrane may be installed over the foam 28 in any of a number of conventional methods. The membrane is identified in Figure 1 as numeral 30.

Referring now to Figure 2, it will be appreciated by one of ordinary skill in the art that the roof of Figure 2 very similar to that of Figure 1; the distinction between the two figures is that an additional reinforcing layer 32 is embedded about half-way between insulation layer 24 and the ultimate top surface of material 28. In one embodiment the reinforcing material 32 is installed in this location by applying less foam 28 over the insulation board 24 such as for example about a half inch of spray foam locating reinforcement material 32 openly adjacent to a half inch sprayed foam and then spraying an additional half inch of foam thereover. It will be understood that the thicknesses of foam indicated herein are only intended for relative purposes and are not intended to be limiting with respect to how thick or how thin the foam is ultimately applied.

The reinforcing material 32 is in one embodiment a mesh material which may comprise fiberglass, nylon, polyester, or other material having similar properties with respect to the purpose for which the reinforcing material 32 is added to the roof system of Figure 2. That is that the material will add tensile strength, rigidity, transverse strength, etc. to the roof system. The reinforcement, if fiberglass, adds fire protection for polystyrene rigid roof insulations from exterior fire sources. Referring now to Figure 3 one of ordinary skill in the art will again recognize that much of the figure is similar to the foregoing figures with places the reinforcing material 32 very near or at the top surface of foam 28. The reinforcing material may be installed in this position by locating material 32 at the top surface of foam 28 prior to curing thereof and may then be sprayed over or urged into foam 28. It is noted that in some applications it may be desirable to utilize slow rising foam in place of faster rising foam 28 for purposes of increasing adherence between the foam layer and the reinforcing material 32. With respect to both Figures 2 and 3 the waterproofing membrane 30 is installed as was indicated with respect to Figure 1.

Referring now to Figure 4 this roofing system could be applied to an existing metal building that did not employ an insulated type roofing system when originally manufactured or built but rather simply utilized the metal deck 14 as the roof system. This disclosed roofing system could also be utilized on a new metal building the builder of which

desires a better roofing system initially. It is worth pointing out that metal decking which is utilized for metal buildings is generally configured with the high flute 40 being narrow and the low flute 42 being relatively wide which in the industry tends to be 12 to 16 inches in width. Because of the wide low flute it is desirable when installing a roof system thereon to  
5 utilize expanded polystyrene flute fillers 44 to effectively level the roof surface prior to installing upwardly adjacent layers. In this embodiment fillers 44 are effectively glued in place by slow rise foam 46 which has been sprayed over the deck 14 relatively uniformly in all locations but, of course, in accordance with the former teachings of this application, with particular attention paid to penetrations of the roof deck in order to prevent air leakage  
10 therethrough. Slow rise foam 46 is utilized in this regard in order to provide time for roof installers to position flute filler 44 prior to curing of material 46. Subsequent to the installation of the flute filler 44 a relatively uniform coating of slow rise material 48 is sprayed over the entirety of the roof and insulation 50, generally in board form, is set into slow rise material 48 prior to curing thereof in order to adhere the insulation 50 to the  
15 underlying roof component removing the need for metal fasteners for insulation 50 which would otherwise create thermal bridges through that insulation as has been evident in prior art roof structures.

Since it is well known in the art that insulation 50, particularly if it is polystyrene or polyisocyanurate insulation cannot be left open to the elements therefore spray  
20 foam layer 52 is applied to the top surface 54 of insulation 50 to seal and protect the same. In one embodiment foam 52 would be about an inch thick. As in the foregoing embodiments the temporary roof structure is created without membrane 30 but membrane 30 will be desirably be installed upwardly adjacent the foam layer 52 when work on the building is completed.

25 Referring now to Figure 5, one of ordinary skill in the art will recognize some of the components of this figure are similar to those of Figure 4 and therefore are numbered similarly in this embodiment. No insulation layer 50 is utilized but rather thicker sections of foam are utilized instead. In addition, a reinforcing layer 32 is installed. One method of installing this roof system starts as does the Figure 4 embodiment with slow rise foam 46  
30 adhering flute fillers 44 to low flutes 42 of the deck 14. Immediately upwardly adjacent flute

fillers 44, a layer of foam 60 is applied which is, in one embodiment, about a half inch thick or thicker. It is again to be understood that this measurement is for exemplary and comparative purposes rather than for limiting purposes. More or less spray foam could be used at will. Reinforcing material 32, which may be a mesh material such as a fiberglass, nylon, polyester or other similar property mesh as was the case in the foregoing  
5 embodiments, is positioned upwardly adjacent foam layer 60. In the event that foam layer 60 utilizes slow rise foam, reinforcing material 32 is likely to be adhered to that foam. In the event that a fast rising/fast curing foam layer 60 is utilized it is possible that the reinforcing layer 32 may not adhere to layer 60. Reinforcing layer 32 is mechanically fastened by  
10 fastener 62 through foam layer 60, through flute filler 44 and through deck 14 to mechanically attach the roof system to the deck. While a mechanical fastener is utilized herein which raises concern about thermal bridging effects, it is noted that the fastener does not bridge all the way to the top surface of the roofing system and therefore the thermal bridging effects of the prior art are lessened or nullified in this embodiment. Subsequent to  
15 mechanically attaching the reinforcing material 32 to the roof deck an additional layer of foam material 64 is applied to a top surface of the mesh 32. This may be of any thickness but in one embodiment will be about a half inch. As in the foregoing embodiments, once cured layer 64 the roof is temporarily water sealed and building construction activity across and thereon is permissible. Once work is done with respect to the building, the roofing  
20 membrane 30 is installed upwardly adjacent the top surface of foam layer 64 in a conventional way such as loose laid, fully adhered, mechanically attached, etc.

In the embodiment of Figure 6, a foam material 70 is applied to air seal a previously existing roofing assembly 71. The roofing assembly 71 is upwardly adjacent a roof deck 72, which may be a metal corrugated roof decking material that is fastened to an  
25 underlying support structure 74 by conventional means such as fasteners 76 or welding. The previously existing roofing assembly 71 may be a built up roof, which includes an insulation layer 78, such as fiberboard, fiberglass, or gypsum board.

The roofing assembly 71 is uniformly (relatively) covered by the foam 70, which may be a polyurethane foam, polyurea compound, or other material having similar  
30 properties and also including combinations of materials, including at least one of the

foregoing materials. The foam 70 may be a slow curing foam or a fast curing foam, depending upon functionality desired by the installer, and may be applied to the roofing assembly 71 in multiple layers or a polyurea polymeric adhesion. If, as illustrated in Figure 6, reinforcing mesh 78 (which may comprise fiberglass, nylon, or polyester or other material having similar properties with respect to the purpose for which the reinforcing mesh 78 is added) is to be embedded in the foam 70, the foam 70 may be applied in a first layer 80 and an additional layer 82, with the first layer 80 being slow cure polyurethane type foam. Slow cure foam is desirable in this case because it allows adherence of the reinforcing mesh 78 to the uncured newly sprayed foam 70. The additional layer 82 would likely be fast rise foam material, which will be utilized at this stage of the roof construction since it cures rapidly and allows workers to walk thereon very quickly.

It should be appreciated that the reinforcing mesh 78 discussed above may be embedded at any level within the foam 70. It should also be appreciated that at least one fastener 86, extending at least partially through the foam material 70 and into the roof deck 72, may also be used in conjunction with the foam material 70 and previously existing roofing assembly 71. These fasteners 86 more securely fix the foam 70 with the roofing assembly 71. As shown in the Figure, a waterproofing membrane 84 is also disposed upwardly of and adjacent to the foam 70.

Each of the embodiments described hereinabove have substantial benefit with respect to the roofing industry. The first benefit is that the foam material utilized substantially enhances structural integrity of the roofing system. The second benefit is that for the metal-deck type systems the dew point on the building side surface of the metal deck has substantially changed such that condensation does not form and rust is substantially reduced. The third benefit is that a temporary roof is created which is rapid and relatively easy to install, prevents damage to underlying roof components and allows work to continue on the building without risk of damaging a roof waterproofing membrane. The fourth benefit is a substantially increased R-value of the roof system due to enhanced insulated properties of the foam material and due to the lack of thermal bridges existing within the structure.

While preferred embodiments of the invention have been shown and described, various modifications and substitutions may be made thereto without departing

from the spirit and scope of the invention. Accordingly, it is to be understood that the present invention has been described by way of illustration and not limitation.

What is claimed is:

Claim 1. A roof system comprising:

- a roof deck;
- a previously existing roofing assembly upwardly adjacent to said roof deck;
- a foam material upwardly adjacent and in air sealing contact with said roofing assembly;
- a layer of reinforcing mesh embedded in said foam material; and
- a waterproof membrane upwardly adjacent of said foam material.

Claim 2. A roof system as claimed in claim 1, wherein said previously existing roofing assembly is a built up roof.

Claim 3. A roof system as claimed in claim 1, including at least one fastener extending at least partially through said foam material and reinforcing mesh into said roof deck.

Claim 4. A method for creating a roof system comprising:

- air sealing a previously existing roofing assembly with a foam material; and
- embedding a reinforcing mesh within said foam material.

Claim 5. A method for creating a roof system as claimed in claim 4, wherein the method further comprises air sealing said previously existing roof assembly with said foam material by applying said foam material in layers.

Claim 6. A method for creating a roof system as claimed in claim 5, wherein said embedding of said reinforcing mesh includes disposing said reinforcing mesh upwardly of and in contact with a first layer of said foam material disposed upwardly of and in contact with said roofing assembly and disposing an additional layer of said foam material upwardly of and in contact with said reinforcing mesh, so as to position said reinforcing mesh between said first layer and said additional layer of said foam material.

Claim 7. A roof system comprising:

a foam material upwardly adjacent and in air sealing contact with a roof deck;  
an insulation layer disposed upwardly of and in contact with the foam material,  
wherein said foam material is configured to cure after disposal of said insulation upon said  
foam material; and

additional foam material disposed upwardly of and in contact with the insulation  
layer, wherein said additional foam material is configured to cure after disposal of said  
additional foam material upon said insulation.

Claim 8. A roof system as claimed in claim 7 wherein a roof water proofing membrane  
is disposed upwardly adjacent the additional foam material.

Claim 9. A roof system as claimed in claim 7 wherein the reinforcing material is  
disposed at an additional foam material.

Claim 10. A roof system as claimed in claim 9 wherein the reinforcing material is  
embedded in the additional foam material.

Claim 11. A roof system as claimed in claim 7 wherein the additional foam material  
exists in more than one layer and a reinforcing material is disposed at an interface between  
adjacent foam layers of the additional foam material.

Claim 12. A roof system as claimed in claim 7 wherein a space around a perimeter of the  
roof system is substantially filled with foam material.

Claim 13. A roof system as claimed in claim 7 wherein a space around a through-roof  
penetration is substantially filled with foam material.

Claim 14. A roof system as claimed in claim 8 wherein the membrane is loose laid.

Claim 15. A roof system as claimed in claim 8 wherein the membrane is totally adhered.

Claim 16. A roof system as claimed in claim 8 wherein the membrane is mechanically attached.

Claim 17. A roof system comprising:

a foam material upwardly adjacent and in air sealing contact with a roof deck;  
an insulation layer disposed upwardly of and in contact with the foam material,  
wherein said foam material is configured to cure after disposal of said insulation upon said foam material; and

additional foam material disposed upwardly of and in contact with the insulation layer  
wherein said additional foam material is configured to cure after disposal of said additional foam material upon said insulation material, and wherein said foam material and said additional foam material fully enclose said insulation layer.

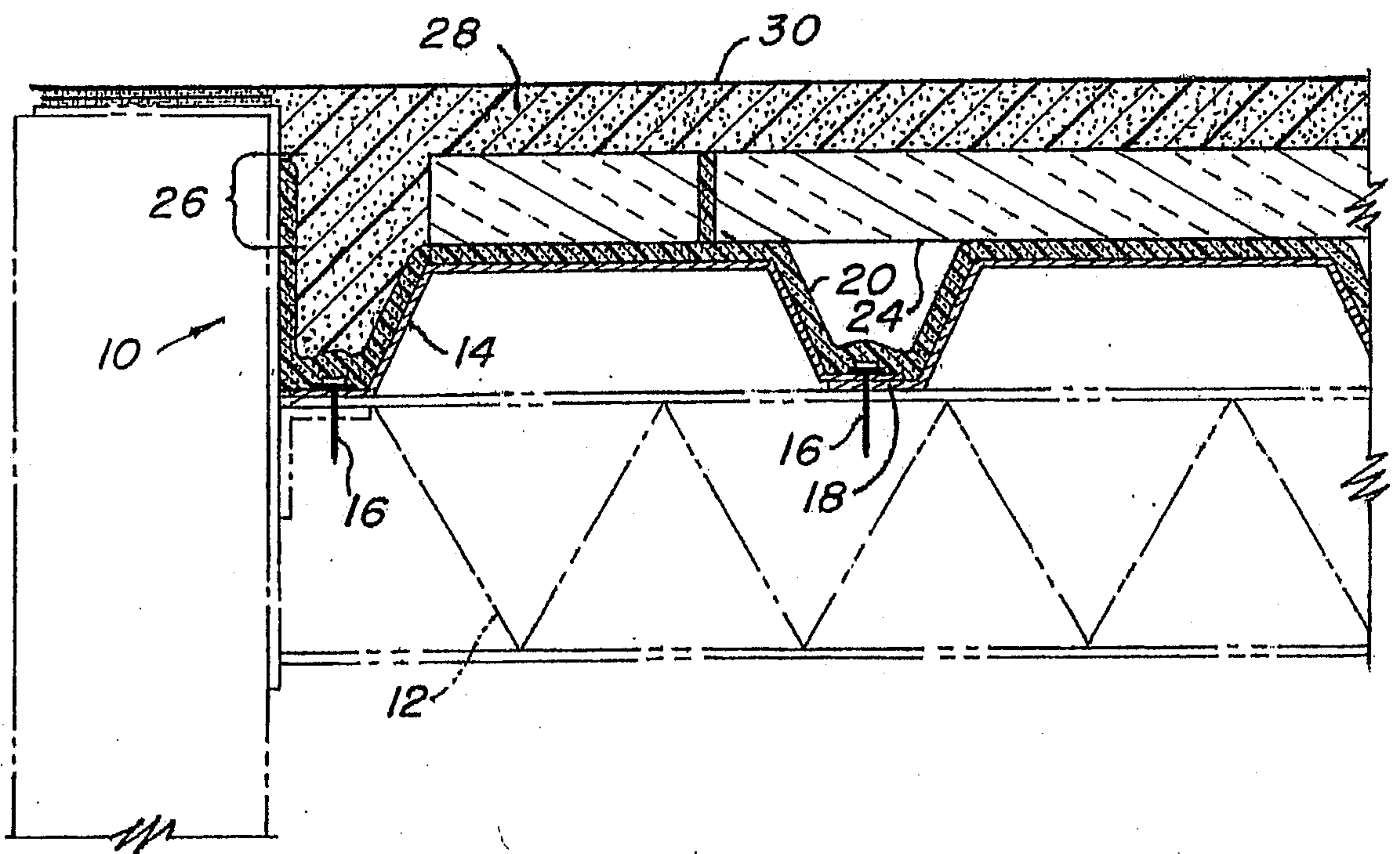

FIG. 1

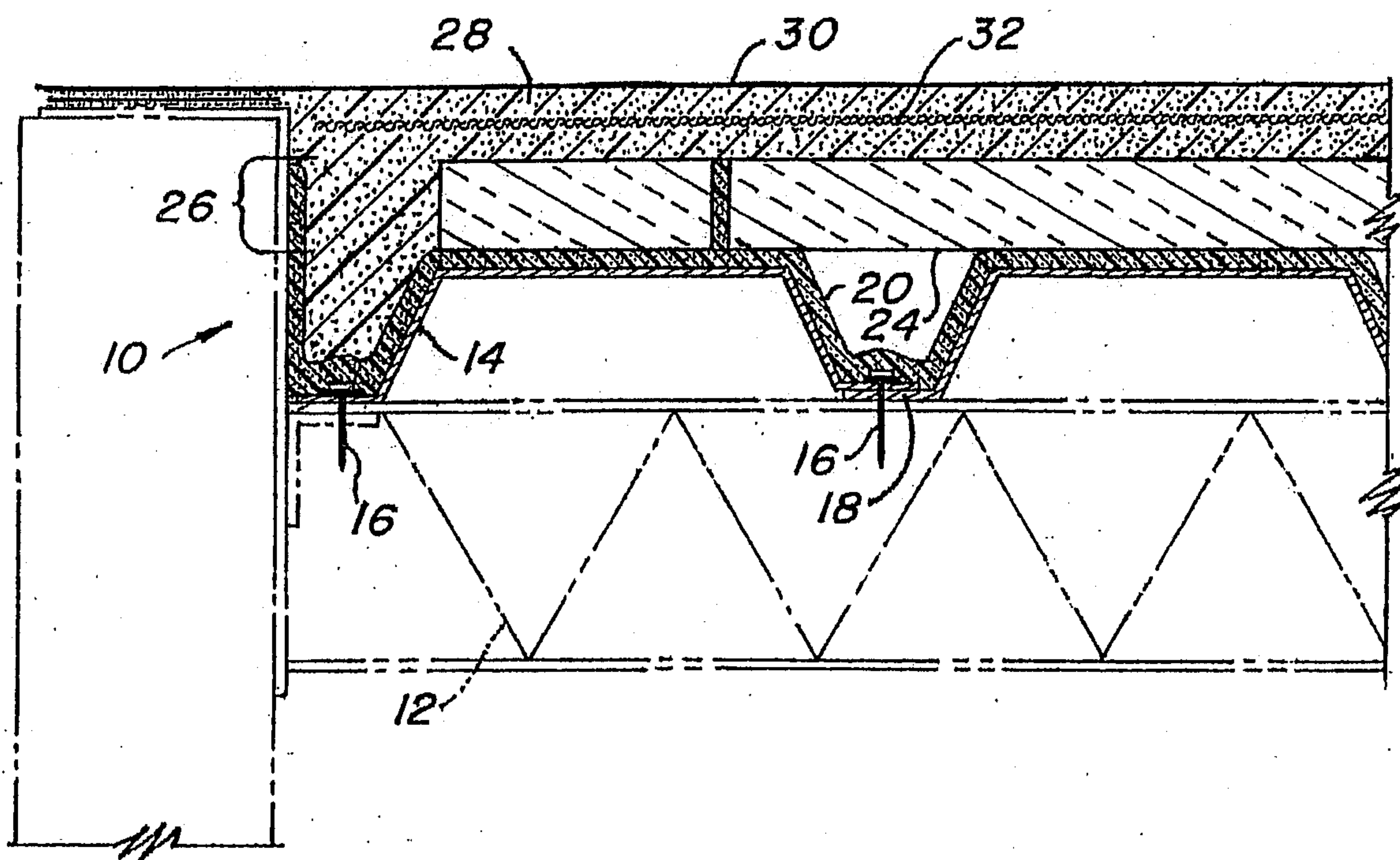

FIG. 2

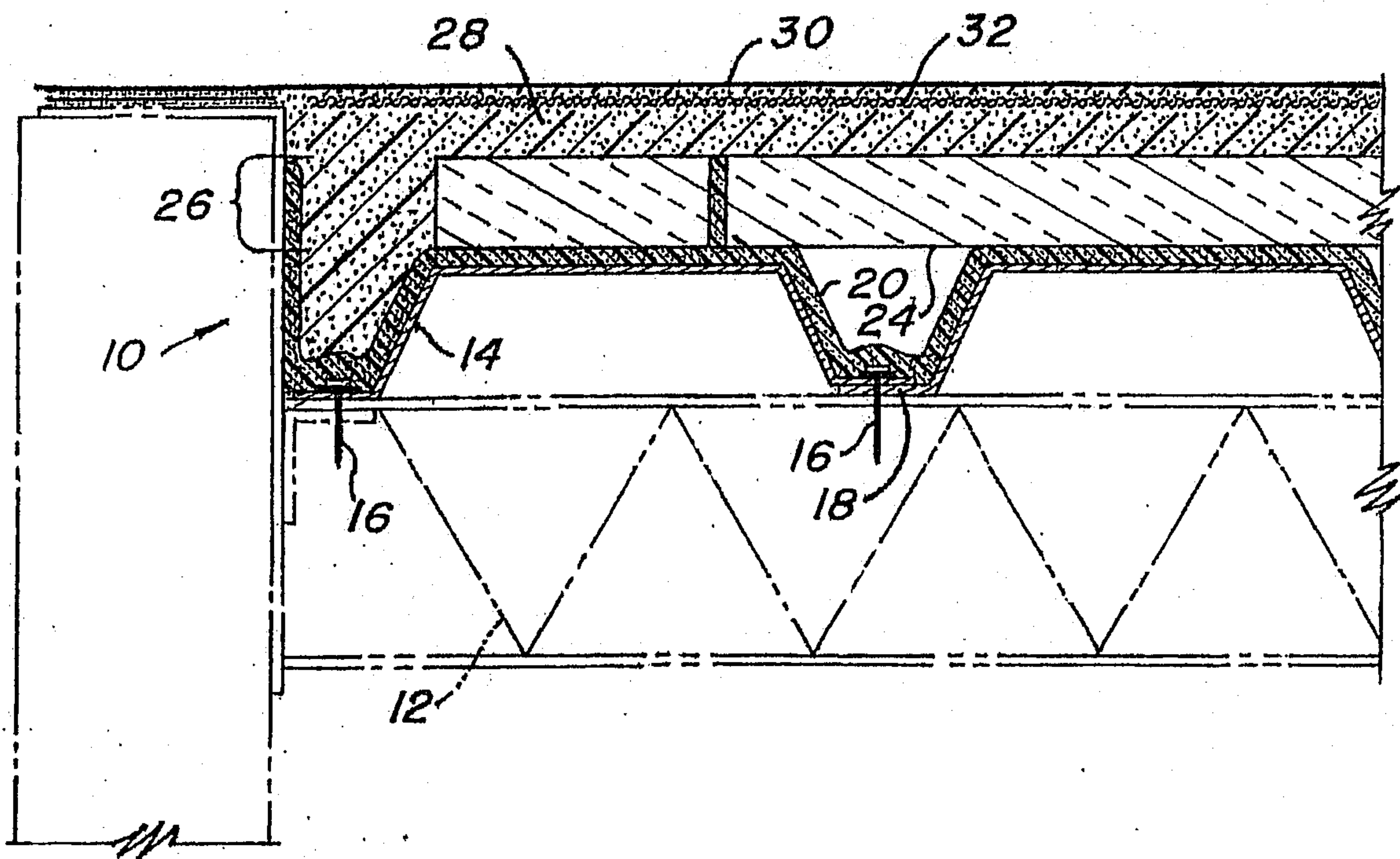

FIG. 3

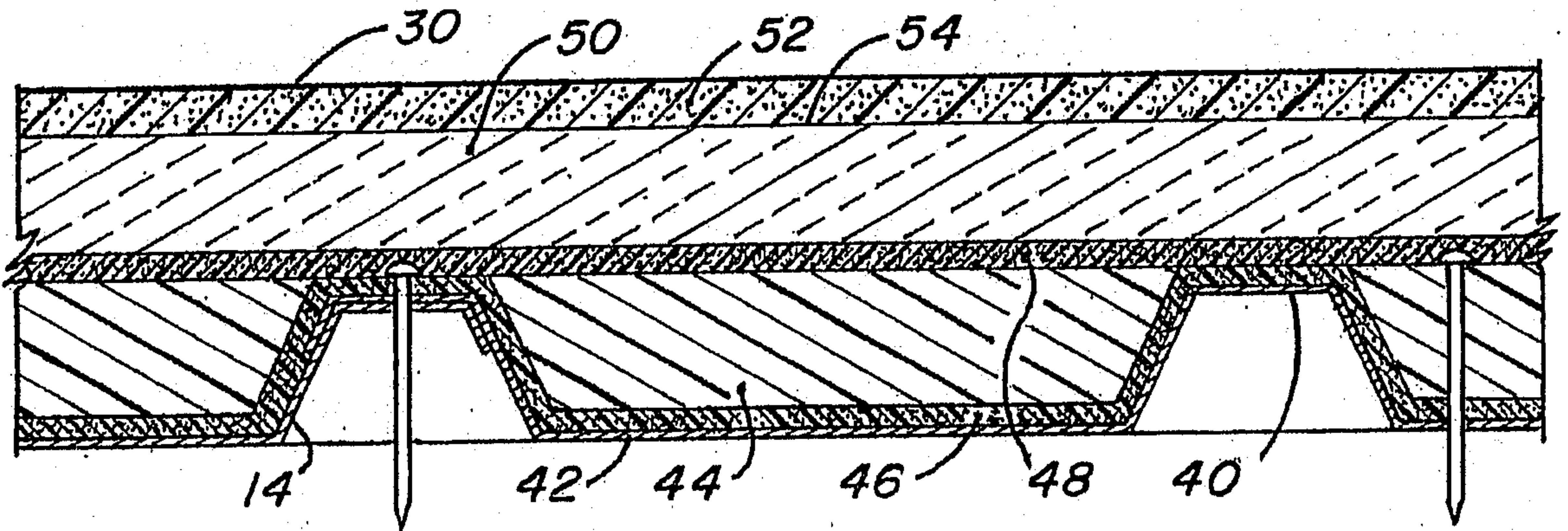

FIG. 4

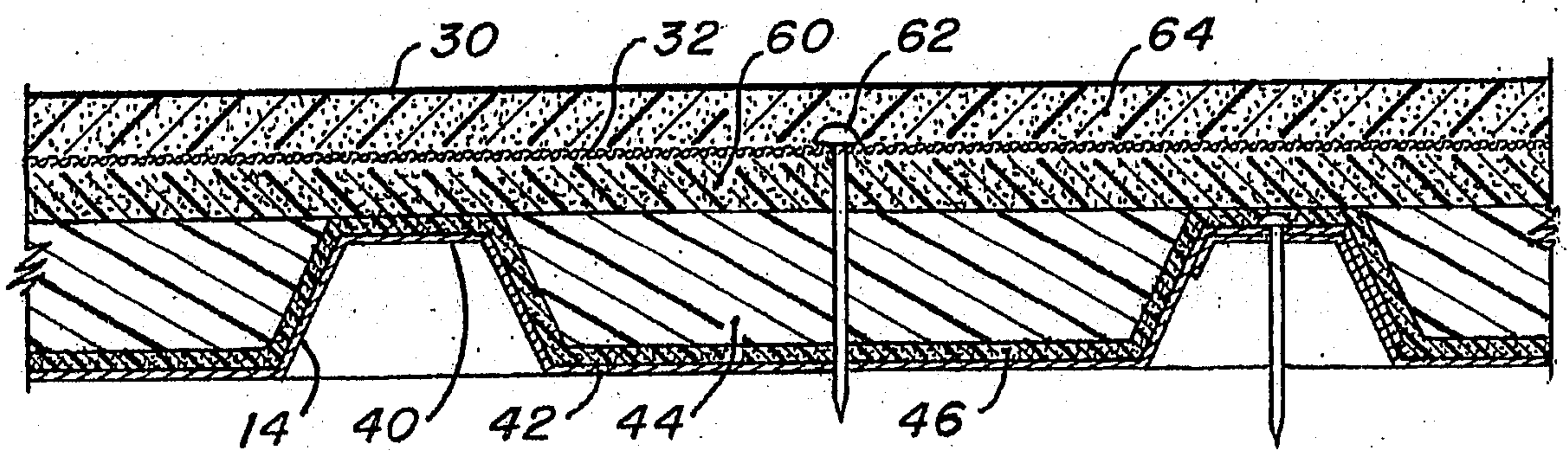

FIG. 5

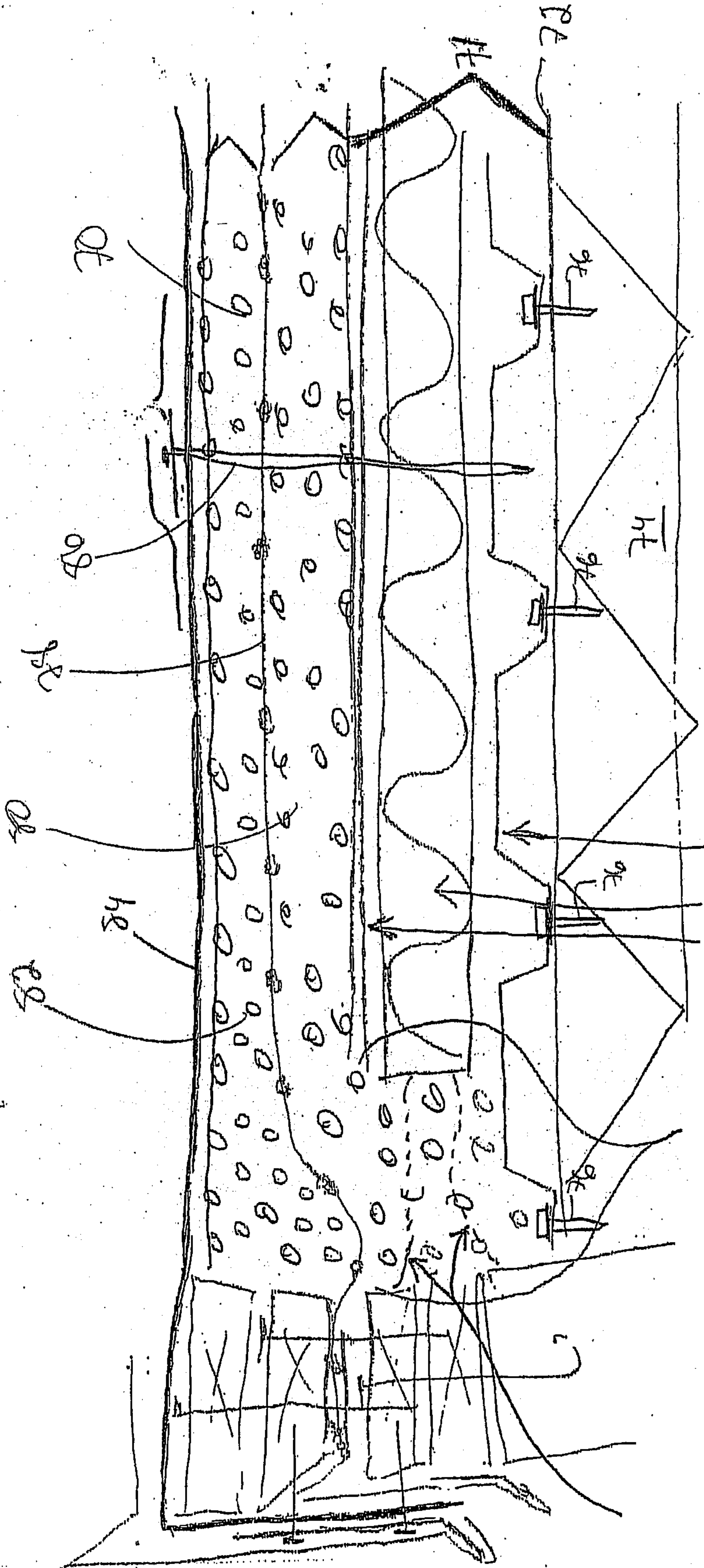

Figure 6

