

(No Model.)

4 Sheets—Sheet 1.

F. A. MILLS.
TENSION DEVICE FOR SHOE SEWING MACHINES.

No. 524,335.

Patented Aug. 14, 1894.

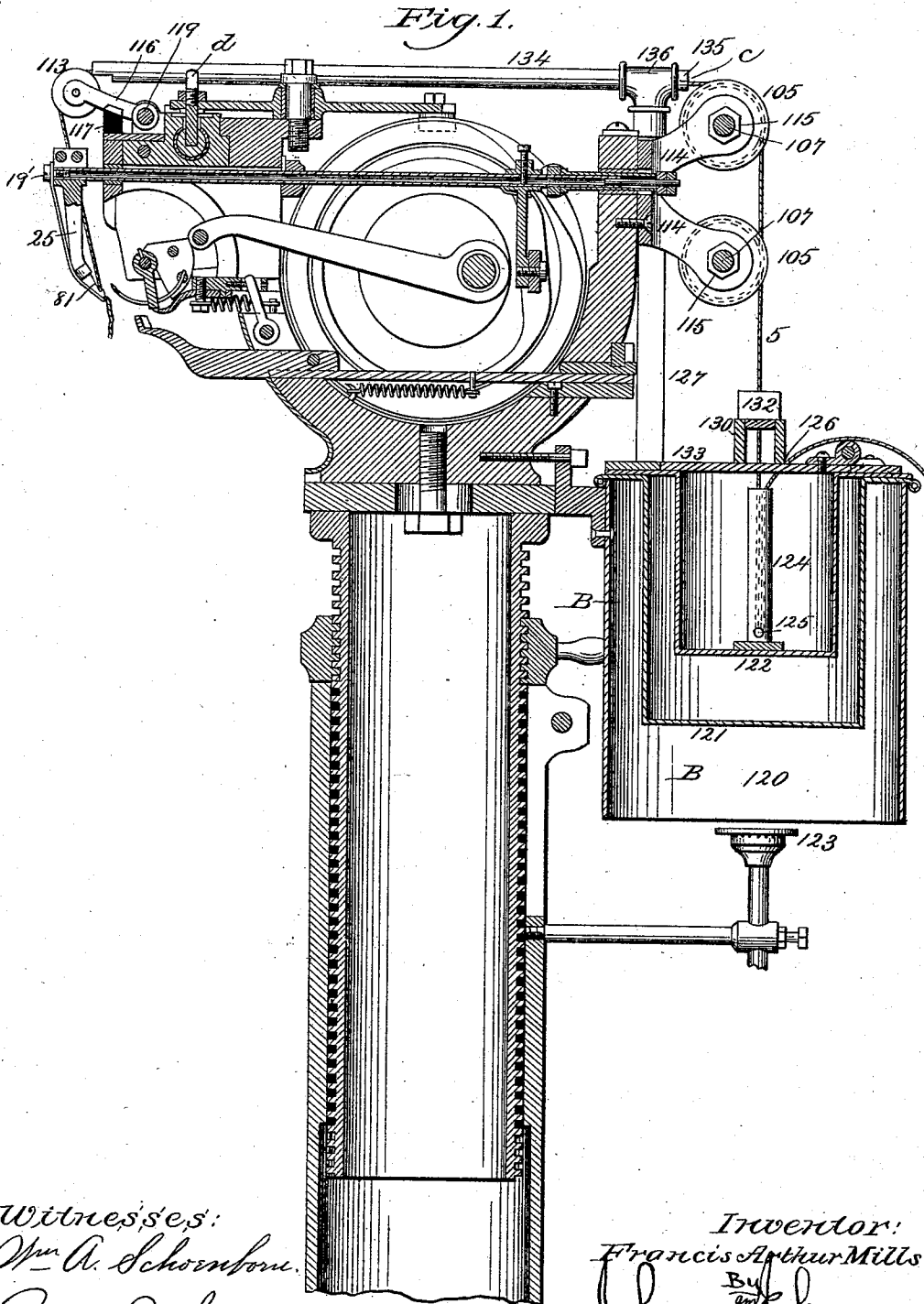

Witnesses:
Wm. A. Schoenborn.
Chas. Johnson

Inventor:
Francis Arthur Mills.
By
Johnson & Johnson
His Attorneys

(No Model.)

4 Sheets—Sheet 2.

F. A. MILLS.
TENSION DEVICE FOR SHOE SEWING MACHINES.

No. 524,335.

Patented Aug. 14, 1894.

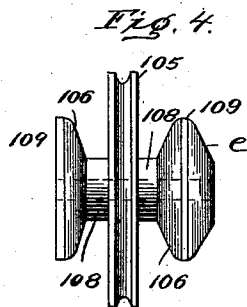
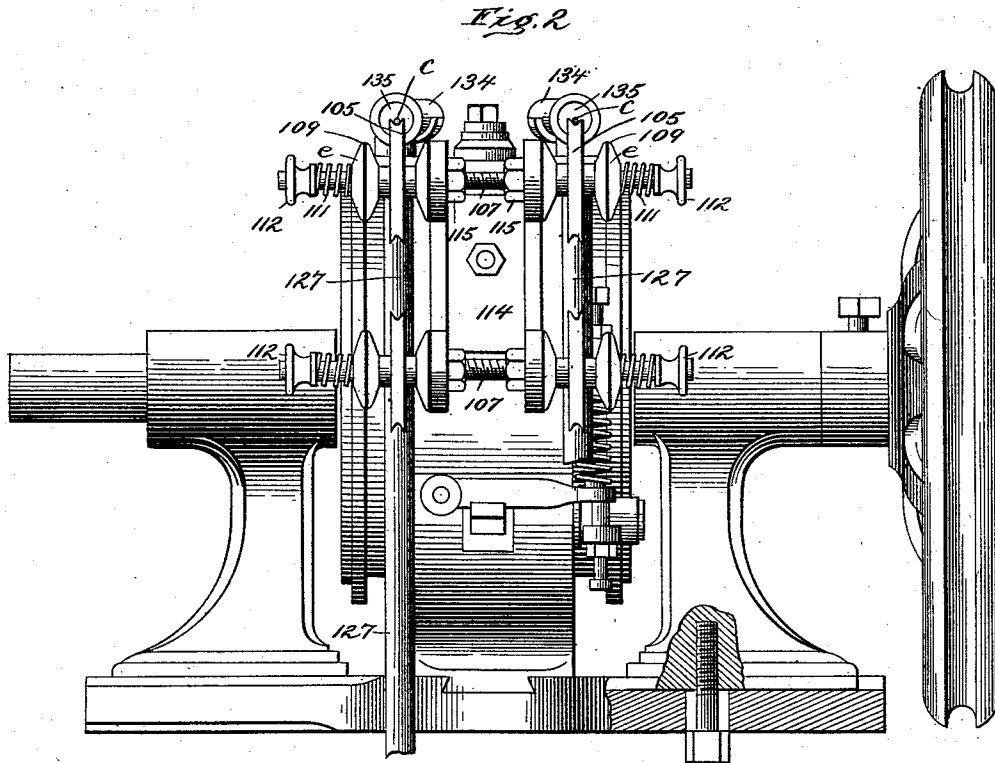

witnesses
Edwin L Bradford
Ouy Johnson

Inventor:
Francis Arthur Mills.
By *Johnson*
His Attorneys

(No Model.)

4 Sheets—Sheet 3.

F. A. MILLS.
TENSION DEVICE FOR SHOE SEWING MACHINES.

No. 524,335.

Patented Aug. 14, 1894.

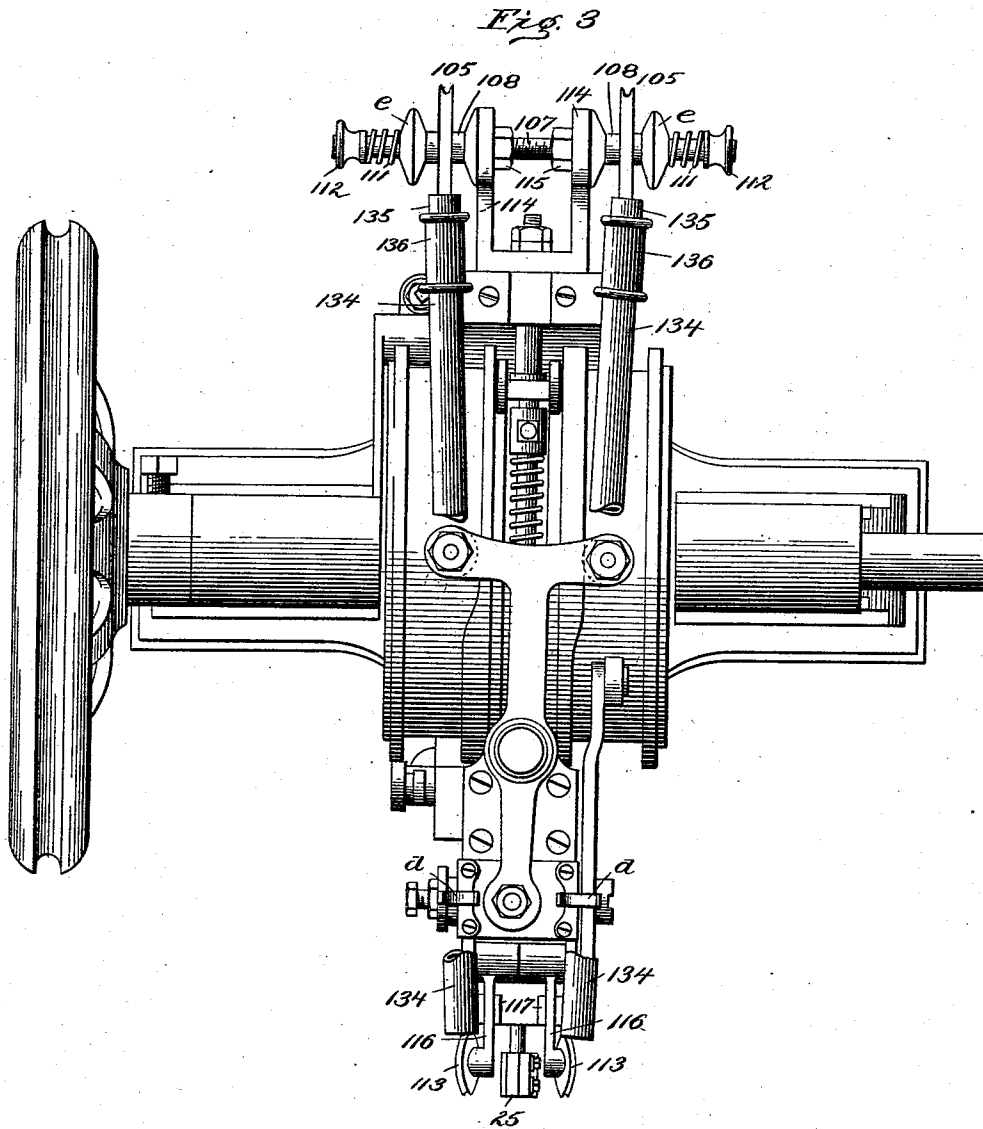

witnesses:

Edwin L Bradford

Chas. H. Johnson

Inventor:
Francis Arthur Mills

By Johnson & Johnson

his Attorneys.

(No Model.)

4 Sheets—Sheet 4.

F. A. MILLS.

TENSION DEVICE FOR SHOE SEWING MACHINES.

No. 524,335.

Patented Aug. 14, 1894.

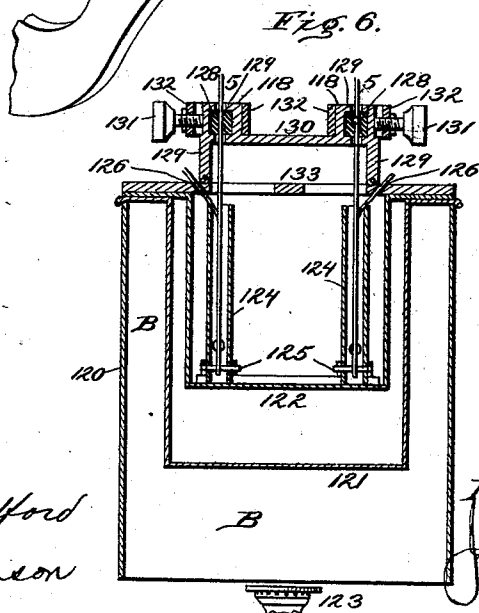
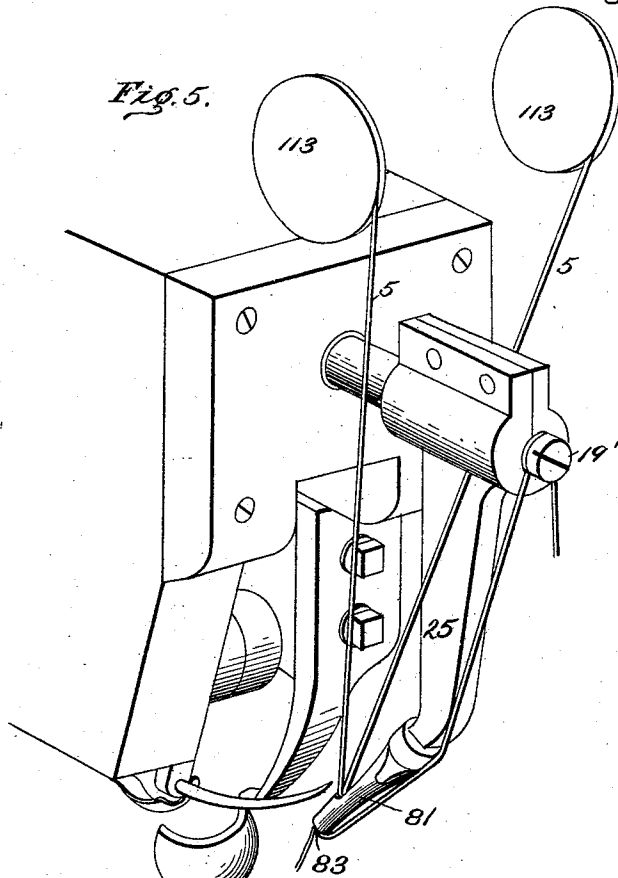

Witnesses

Edwin L. Bradford
August Johnson

Inventor
Francis Arthur Mills.

By
Johnson
His Attorneys

UNITED STATES PATENT OFFICE.

FRANCIS ARTHUR MILLS, OF PHILADELPHIA, PENNSYLVANIA, ASSIGNOR,
BY MESNE ASSIGNMENTS, OF ONE-HALF TO JAMES MUNDELL, OF SAME
PLACE.

TENSION DEVICE FOR SHOE-SEWING MACHINES.

SPECIFICATION forming part of Letters Patent No. 524,335, dated August 14, 1894.

Application filed January 28, 1893. Renewed November 14, 1893. Serial No. 490,965. (No model.)

To all whom it may concern:

Be it known that I, FRANCIS ARTHUR MILLS, a citizen of the United States, and a resident of the city of Philadelphia, in the county of Philadelphia and State of Pennsylvania, have invented certain new and useful Improvements in Tension Devices for Shoe-Sewing Machines, of which the following is a specification.

The invention claimed herein is directed to improvements in tension devices for shoe sewing machines wherein a curved barbed needle operates with a waxed thread and in which the operator presents and manipulates the work to devices which support and feed it; and my said invention consists in certain novel parts and combinations of parts hereinafter specifically set out in the claims concluding this specification. Before specifying such claims I will describe my improved tension device illustrated in the drawings.

The following description read in connection with the drawings will enable any one skilled in the art to which my invention relates to understand its nature and to practice it in the form in which I at present prefer to employ it.

Referring to the drawings: Figure 1 represents in vertical central section a shoe sewing machine having my improved tension device for the thread. Fig. 2 is a rear elevation of the tension device and so much of the machine on which it is mounted. Fig. 3 is a top view of the same. Fig. 4 shows one of the tension wheels and its tension disks. Fig. 5 shows so much of the sewing-head of the machine and the sewing mechanism as illustrates the employment of two separate and distinct threads for independent use with the looper and the needle for light and for heavy work; and Fig. 6 shows in vertical section the waxing appliance for the two separate and distinct threads.

As the invention claimed herein relates to the tension device and its adaptation for two separate and distinct threads for independent use with a looper and a needle, I have illustrated in the drawings so much of a shoe sewing machine as shows the use of two threads and their relation with the looper which car-

ries both in its looping finger, but with one of such threads hung up out of use. It will be understood, however, that my tension device is applicable to any shoe sewing machine designed for use with waxed threads; and in which the work is presented and manipulated to devices for supporting and for feeding the work. The tension device is mounted upon the rear side of the machine and I have shown the two threads 5, 5, as being supplied from a waxing and heating device to the looper of a sewing machine.

The tension device consists of a pair of single groove tension wheels 105 arranged one above the other each mounted loosely upon a horizontal shaft 107 fixed in a suitable bracket. Each friction wheel has a sleeve 108 Fig. 4 which projects from the opposite sides of the wheel and has a disk 106 on each end which stands away from the wheel and engages a suitable friction surface such as felt 109, which forms the facing of a co-acting surface *e* and which latter has a spring 111 on said shaft to maintain the frictional contact of the disks. A nut 112 on the shaft serves to regulate the tension of the spring and the tension of the thread. The placing of the friction disks 106 on the ends of the sleeve is to remove them from the wheel and thus prevent the friction pads 109 from being gummed with dripping wax, which would, to a great extent, interfere with the proper tension and feed of the thread and give the operator much trouble; for, in wax-thread machines the tension wheels are kept hot from the thread as it comes from the hot wax-pot and the wax will gather on the wheels and run or drip over them upon the friction pads so that the pads have to be removed and replaced by new ones frequently from this cause. The thread 5 is wound once around each wheel from the lower to the upper one from their rear peripheries and from the upper tension wheel it passes through the heating conduits over a cushioned guide wheel 113 at the front of the machine to the looper 25. By using a pair of tension wheels the pressure of the tension of each wheel is about one half of what would be required for one tension wheel, and this divided tension force

prevents the slipping of the threads which occurs under the pulling action of the needle with one wheel adjusted to give the required tension. The slipping of the thread is attended with the objection of failing to put the proper tension in the stitches whenever the thread should slip. The thread is kept under uniform tension as it is drawn from the wax stripper; while cushion guide wheel maintains the proper tension on the thread as it passes to the looper. The important matter of the single groove pair of wheels with the thread wound around them once as described, is, that it allows only half the full tension to be put upon each wheel by the thumb screw, and this permits the tension wheels to turn loosely on their shafts before the thread would slip, as the thread would have a greater friction on the wheel than the spring would put upon the felt. I secure the shafts of the tension wheels to a bracket 114 by jam nuts 115 so that the shafts cannot turn. To allow the thread to have a yielding feed to the looper, the guide wheel is mounted upon a pivoted arm 116 which rests upon a cushion 117.

It must be understood that in order to prevent the friction pads from being gummed and destroyed by hot wax dripping thereon from the tension wheel, the pads must be isolated from the wheel. For this purpose I make the friction disks of greater diameter than the sleeves so that, although the latter may be covered with the dripping wax from the sides of the wheel, the pads not only standing away from the latter, but also away from the surface of the sleeve, will be thereby shielded and protected from the dripping wax. Even if the sides of the disks should gather wax, they can be cleaned and their edges kept free from gum.

In sewing shoes of light and heavy stock it is the practice to change the thread to suit the different work and in doing this the thread must be cut at a point outside the wax pot in order to join it with a lighter or with a heavier thread as may be required for the work. In doing this the cut part of the thread is tied to the end of the new thread and the latter is drawn through the machine and the cut part of the thread is thrown away. The time of the operator is lost in passing the new thread into the machine and adjusting the tension to suit the work. This is troublesome and the handling of the thread smears the operator's hands with wax and this changing of the threads is otherwise objectionable. To save all this trouble, loss of time and inconvenience, I provide the machine with tension devices for two different threads suited for light and for heavy stock. For this purpose the tension device which I have described is duplicated so that each tension device has a pair of single groove tension wheels, one above the other on the separate shafts, and the thread from each set is delivered over the machine at each side of the looper-arm. Both these

threads are passed through the looper finger bore 83 where they are held for separate and independent use. The end of that thread which is not in use is held out of the way at the upper end 19' of the looper arm, as seen in Figs. 1 and 5. The tension having been adjusted for the two threads for different work, they are always in readiness for use, require no changing, and give a uniform tension for all work of the same class, and this advantage is obtained by the employment of two independent and different threads each having an independent tension suited to the work. I use a single casting 114 for this duplex tension device and bolt it to the back of the centerhead; and I use separate cushioned arms 116 for the front guide wheels both mounted on the same pivot pin 119, which is mounted in a plate screwed upon the sewing head.

The waxing and heating appliance is attached to the rear side of the centerhead and is adapted for waxing and for heating the two separate and independent threads. It consists of a drum 120 open at its bottom and from its closed top depends a water chamber 121 and within this chamber the wax pot 122 hangs in the water. A gas burner 123 under the open drum serves to heat the water chamber, the heat from which keeps the wax liquid. Two tubes 124 open at both ends are placed within the wax pot, and at its lower end each tube has a cross pin 125, so that the separate threads 5, 5, from separate balls are passed down through separate top openings 126 into each tube around its bottom pin 125 and up through a wax stripper 118 to the tension device from which it passes into and through heating tubes 134 to the looper finger 81 and to the needle. A wax stripper is placed over each opening through which the thread passes from the wax pot and this stripper consists of two flat pieces of rubber 128 between which the thread passes and is stripped of its surplus wax. These rubber pieces are held between jaws 129 one of which is pivoted to a top housing 130 and is pressed with its rubber against the fixed rubber piece by a thumb screw 131 which passes through one end of an open box or band 132 which surrounds the jaws, so that the screw bearing upon the pivoted jaw puts the proper pressure upon the strippers from which the thread is drawn with the proper tautness and properly waxed. These strippers are arranged in a housing 130 fixed on a hinged cover 133 which is opened to supply wax to the pot.

Communicating with the hot air space B of the heating drums are two tubes 127 which open into separate horizontal branch tubes 134 which are open at both ends. The front ends of these top branch tubes 134 terminate at the cushion guide wheels 113, while a screw plug 135 in the rear end of each top tube has a hole *c* large enough to allow the thread to pass through it from the top tension wheel. The top tubes are thus made to form heating

conduits for the two threads to keep them moist and soft as they pass to the looper and to the needle. There is a top heating tube for each thread resting in seats *d d* at their front ends, and these tubes have swiveling connection by a T-coupling 136 with the vertical branches 127 which permits the top tubes 134 to be turned out for access to the machine when required. The arrangement of the thread conduits at the top of the centerhead, and the arrangement of the waxing and heating appliances at the rear side of the machine, keeps it comparatively cool while the threads are heated and kept soft and pliable and delivered at the front of the machine just above the looper. This arrangement of the thread conduits also permits the tension device and the waxing and heating appliances to be placed at the rear of the machine and in position to deliver the waxed thread directly into the rear ends of the heated conduits and heated air into these conduits at the point at which they receive the threads.

I have illustrated in the drawings the invention claimed herein in connection with a complete shoe sewing machine, but as to matters of devices and of combination of such devices embraced in said machine, other than those which belong to and are covered by the invention claimed herein, they are embodied in separate and distinct applications, Serial Nos. 491,159, 491,160, 491,442, 491,443, and 490,383, for patents filed by me and are therefore not claimed herein.

I claim as my invention in tension devices and thread-holders for shoe-sewing machines—

1. In a sewing machine, the combination, with the looper thereof adapted to receive and hold two independent threads in position for separate use with a needle, of separate and distinct tension devices, and a separate thread supply for each tension device, means for guiding each thread from its tension device to the eye of the looper, and suitable

means for retaining one of said threads in the looper-eye out of the way of the thread being used, substantially as described.

2. In a shoe sewing machine using waxed threads, a grooved tension wheel for the thread having a fixed sleeve at each side terminating in a friction disk 106 of greater diameter than the sleeve and together forming a wheel with isolated friction surfaces, in combination with friction pads 109 for each disk, a supplemental disk 110 co-acting with one of said sleeved-disks, a spring for said supplemental disk, a nut, and a shaft for containing the several parts, whereby the pads are isolated from the thread wheel, for the purpose stated.

3. In a sewing machine, a duplex tension device consisting of a flanged bracket 114, two shafts 107 fixed in and projecting from each side of said bracket, each shaft having on each end a single grooved tension wheel having a fixed sleeve at each side terminating in an enlarged friction disk away from the wheel, friction pads 109 for said disks, a spring and a nut on the end of each shaft and a supplemental disk 110 for each spring co-acting with the enlarged sleeved disk, substantially as described, for the purpose stated.

4. In a sewing machine, the combination with the needle and a looper having an eye in its loop-forming finger adapted to receive and retain two independent threads in position for separate use, of separate thread supplies, a spring sustained guide and support for delivering each thread at each side of and above the looper and a catch on the looper above its eyed-finger for engaging and retaining one of said threads out of use with the needle while the other thread is being used.

In testimony whereof I have hereunto signed this specification in the presence of witnesses.

FRANCIS ARTHUR MILLS.

Witnesses:

A. E. H. JOHNSON,
PHILIP F. LARNER.