



(19) **United States**

(12) **Patent Application Publication**
LATULIPE et al.

(10) **Pub. No.: US 2020/0079514 A1**

(43) **Pub. Date: Mar. 12, 2020**

(54) **HYBRID ELECTRIC AIRCRAFT
PROPULSION SYSTEM AND METHOD**

B64D 27/24 (2006.01)

F01D 15/10 (2006.01)

F02K 3/06 (2006.01)

H02P 5/74 (2006.01)

H02P 9/00 (2006.01)

(71) Applicant: **PRATT & WHITNEY CANADA
CORP.**, Longueuil (CA)

(72) Inventors: **Eric LATULIPE**, Ste-Julie (CA);
Richard Freer, Saint-Basile-Le-Grand
(CA)

(52) **U.S. Cl.**

CPC *B64D 27/02* (2013.01); *B64D 31/06*

(2013.01); *B64D 27/10* (2013.01); *B64D*

27/24 (2013.01); *F01D 15/10* (2013.01); *H02P*

2101/30 (2015.01); *H02P 5/74* (2013.01);

H02P 9/008 (2013.01); *B64D 2027/026*

(2013.01); *F05D 2220/323* (2013.01); *F05D*

2220/764 (2013.01); *F02K 3/06* (2013.01)

(21) Appl. No.: **16/411,262**

(22) Filed: **May 14, 2019**

Related U.S. Application Data

(60) Provisional application No. 62/727,673, filed on Sep. 6, 2018, provisional application No. 62/727,678, filed on Sep. 6, 2018, provisional application No. 62/727,681, filed on Sep. 6, 2018, provisional application No. 62/727,683, filed on Sep. 6, 2018, provisional application No. 62/729,818, filed on Sep. 11, 2018, provisional application No. 62/731,384, filed on Sep. 14, 2018.

Publication Classification

(51) **Int. Cl.**

B64D 27/02 (2006.01)

B64D 31/06 (2006.01)

B64D 27/10 (2006.01)

(57)

ABSTRACT

There is provided a hybrid electric aircraft propulsion system and method for operating same. The method comprises providing, to a first electric motor and a second electric motor, alternating current (AC) electric power from a generator, the generator receiving rotational power from a thermal engine, providing, to the first electric motor and the second electric motor, AC electric power from at least one motor inverter, the at least one motor inverter configured to convert DC electric power from a DC power source into AC electric power, and selectively driving the first and second electric motors from the generator, the at least one motor inverter, or a combination thereof, wherein the first electric motor drives a first rotating propulsor and the second electric motor drives a second rotating propulsor.

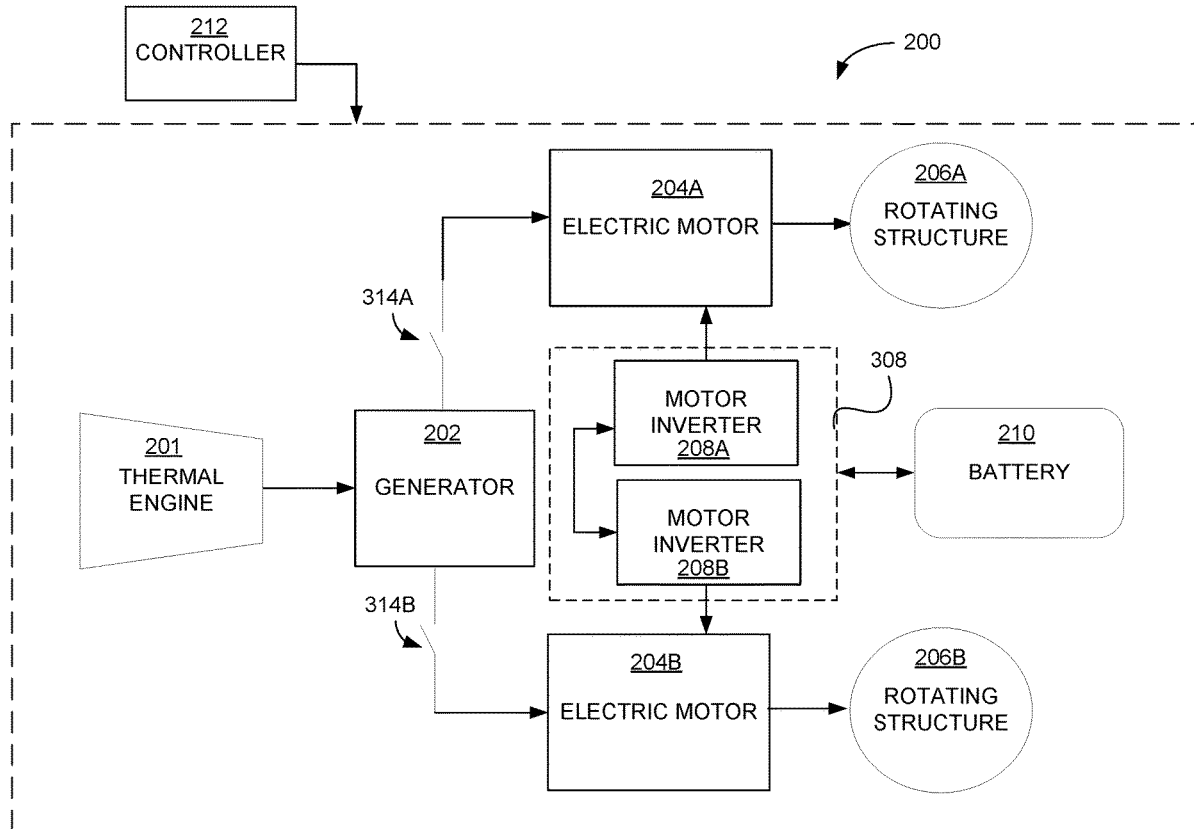

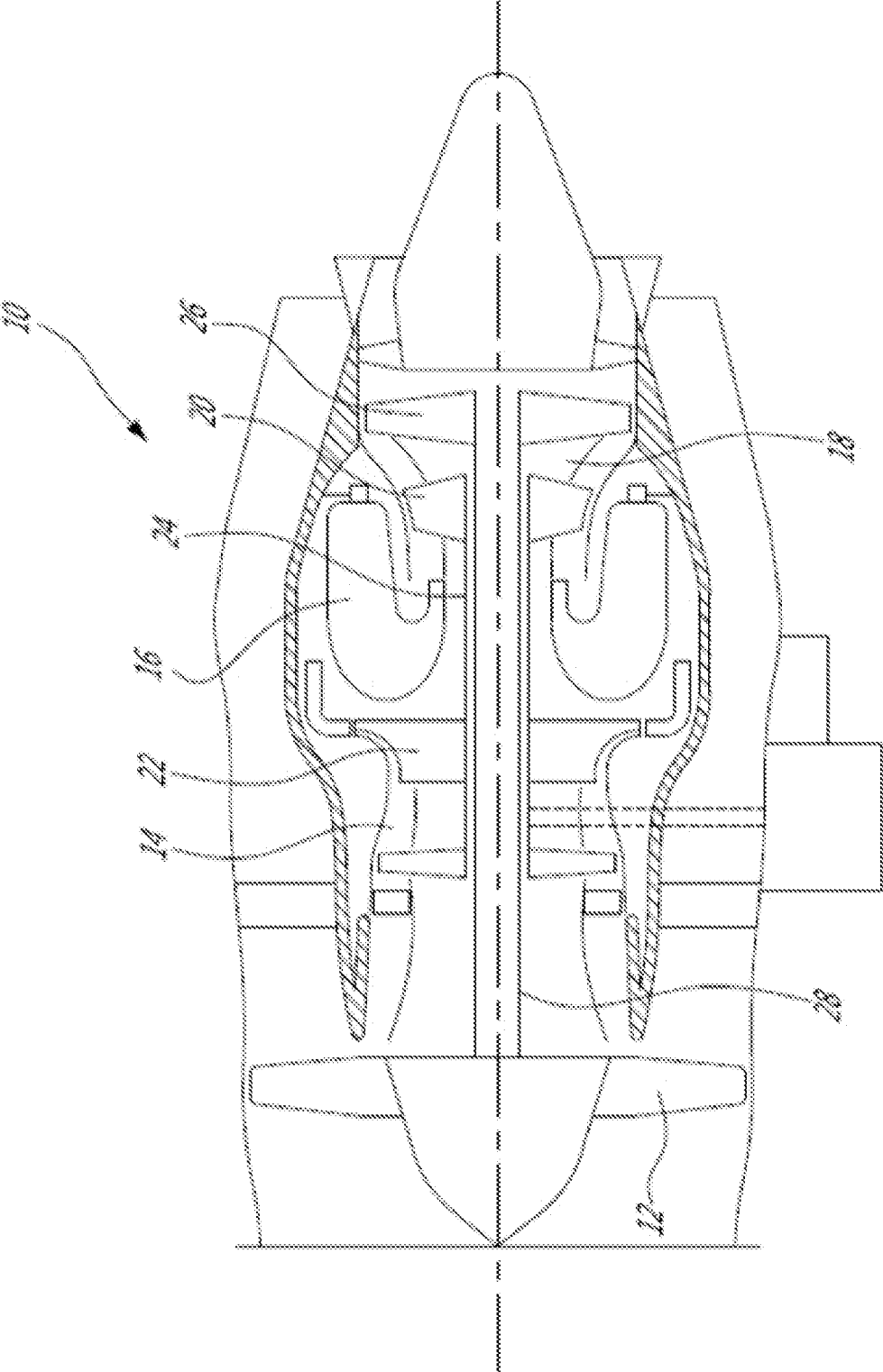

FIGURE 1

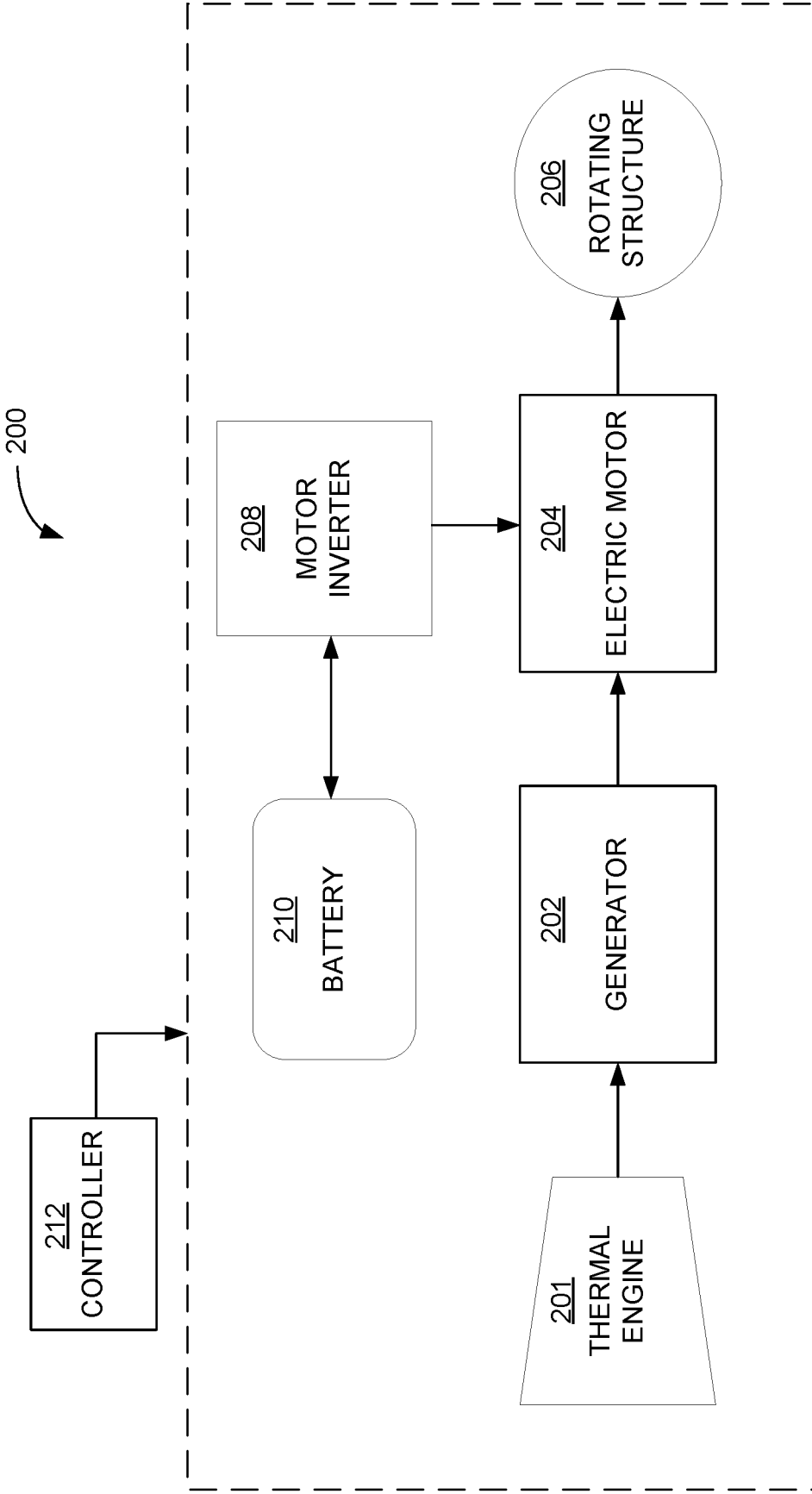

FIGURE 2

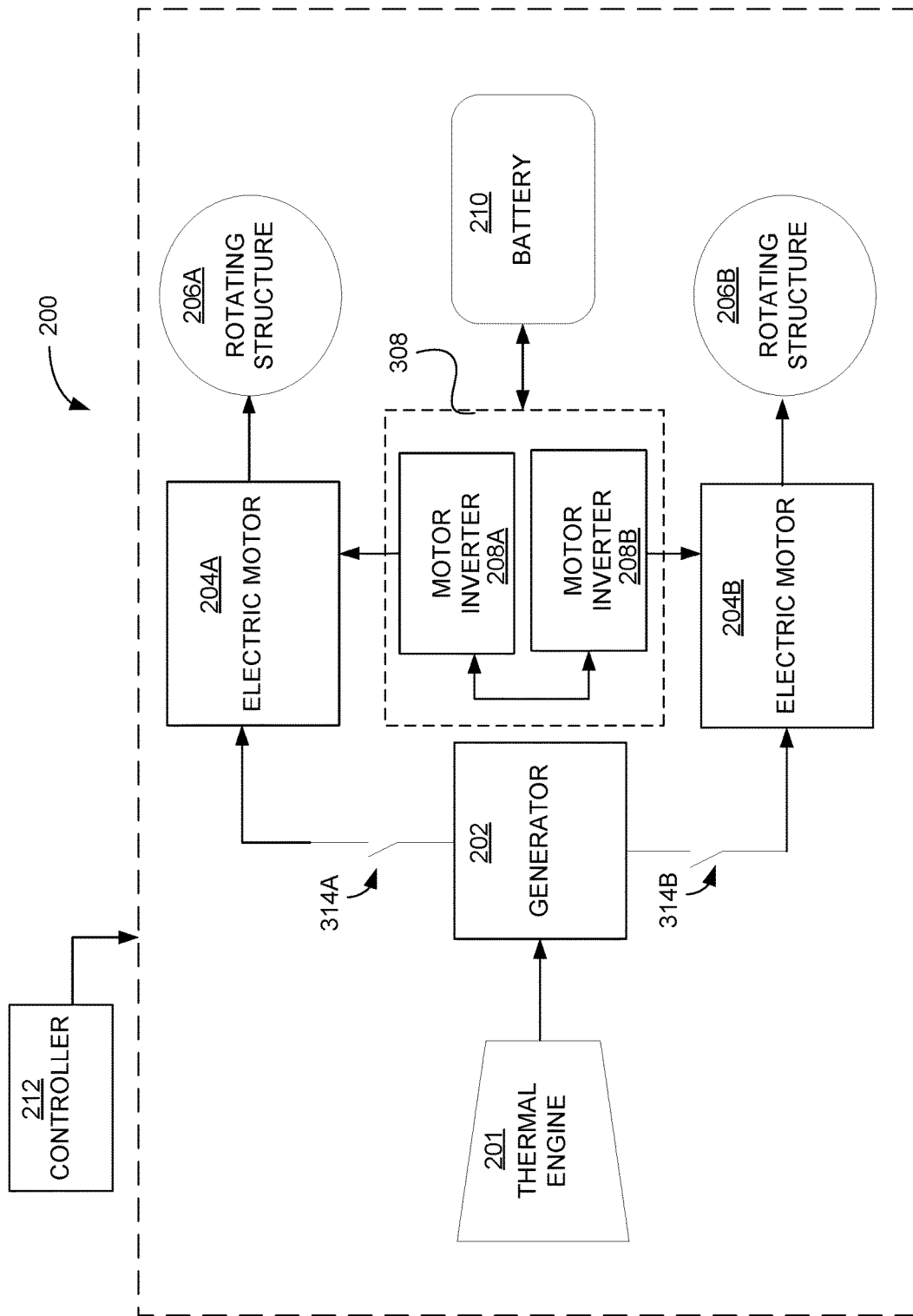

FIGURE 3

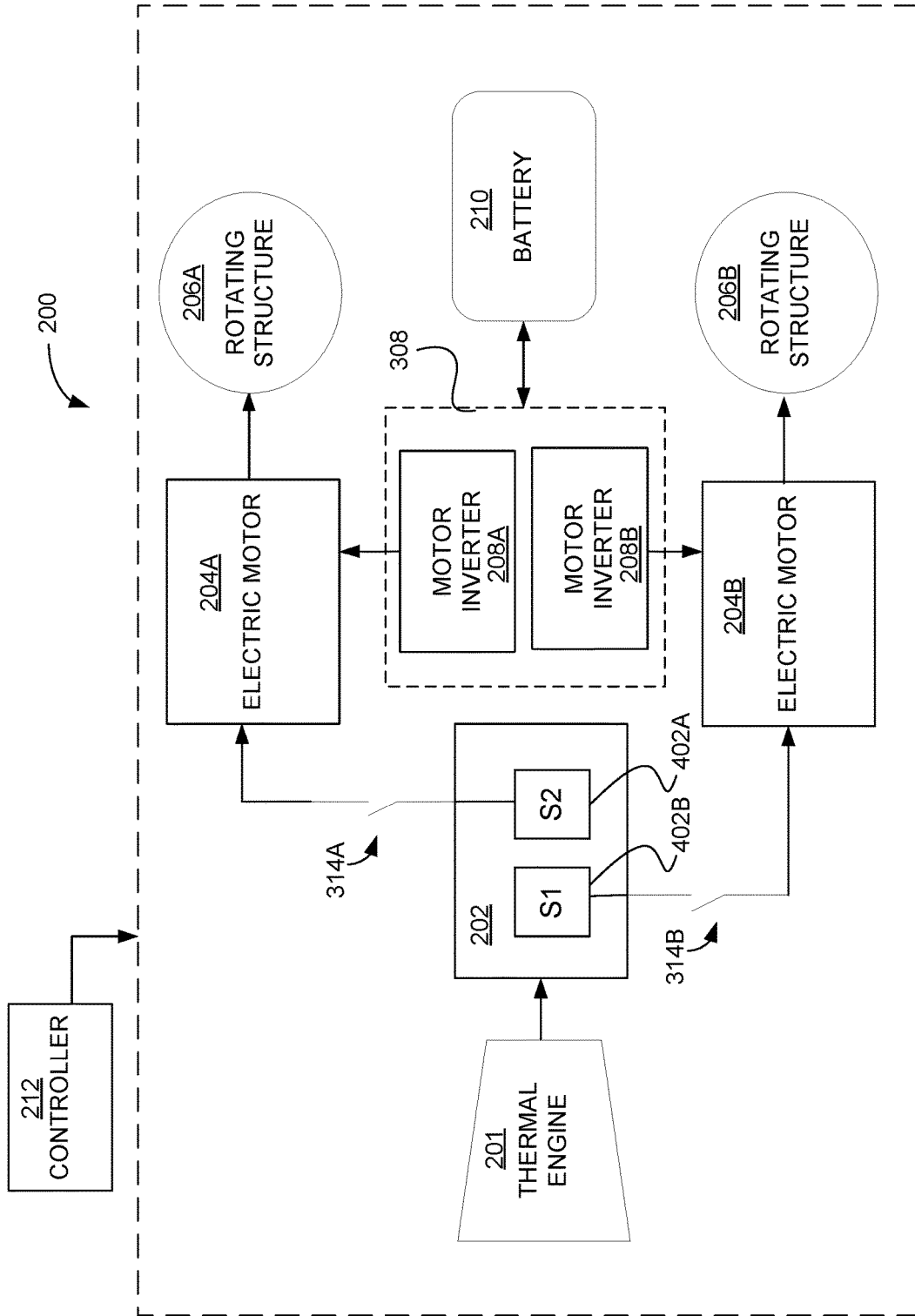

FIGURE 4

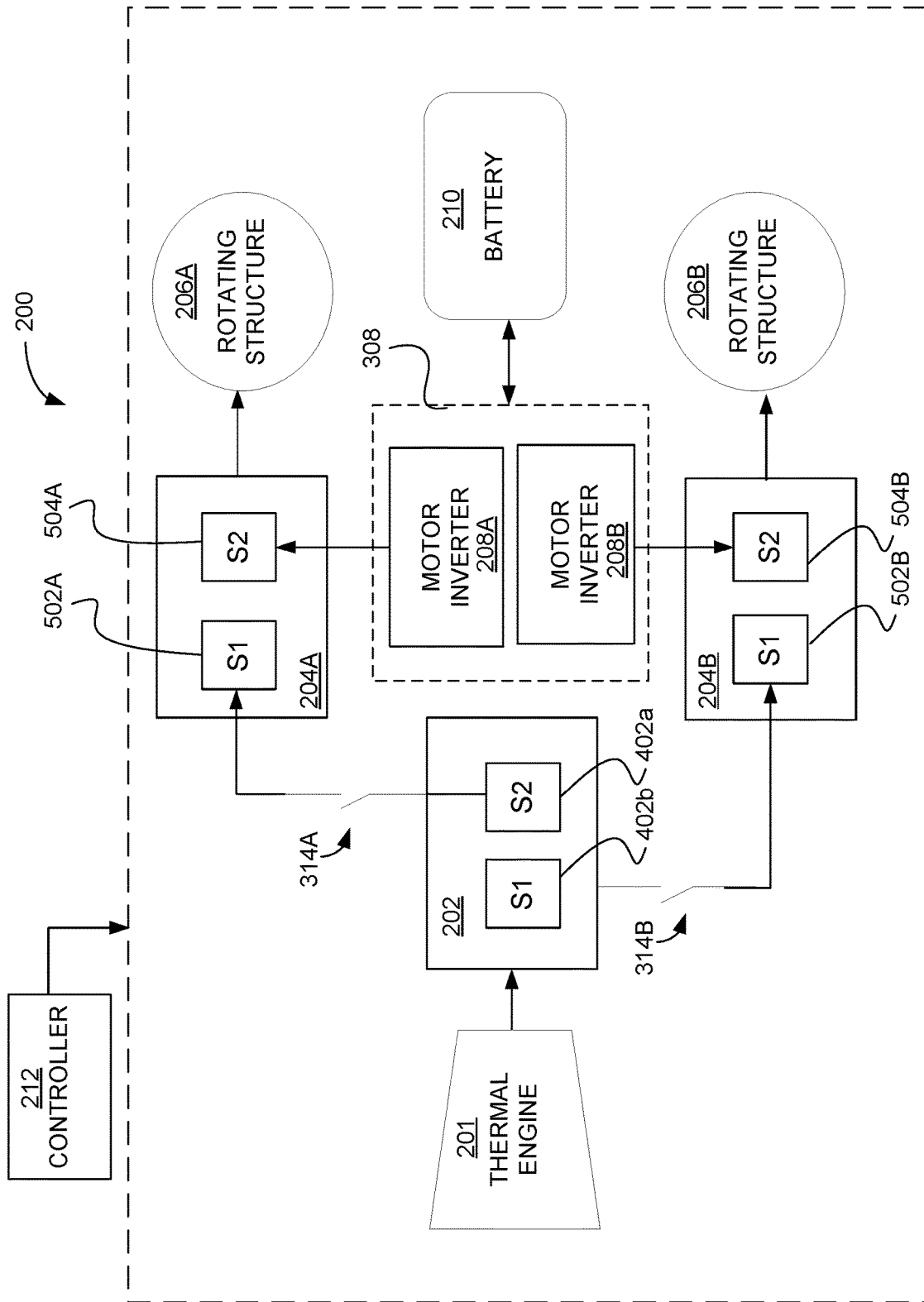

FIGURE 5

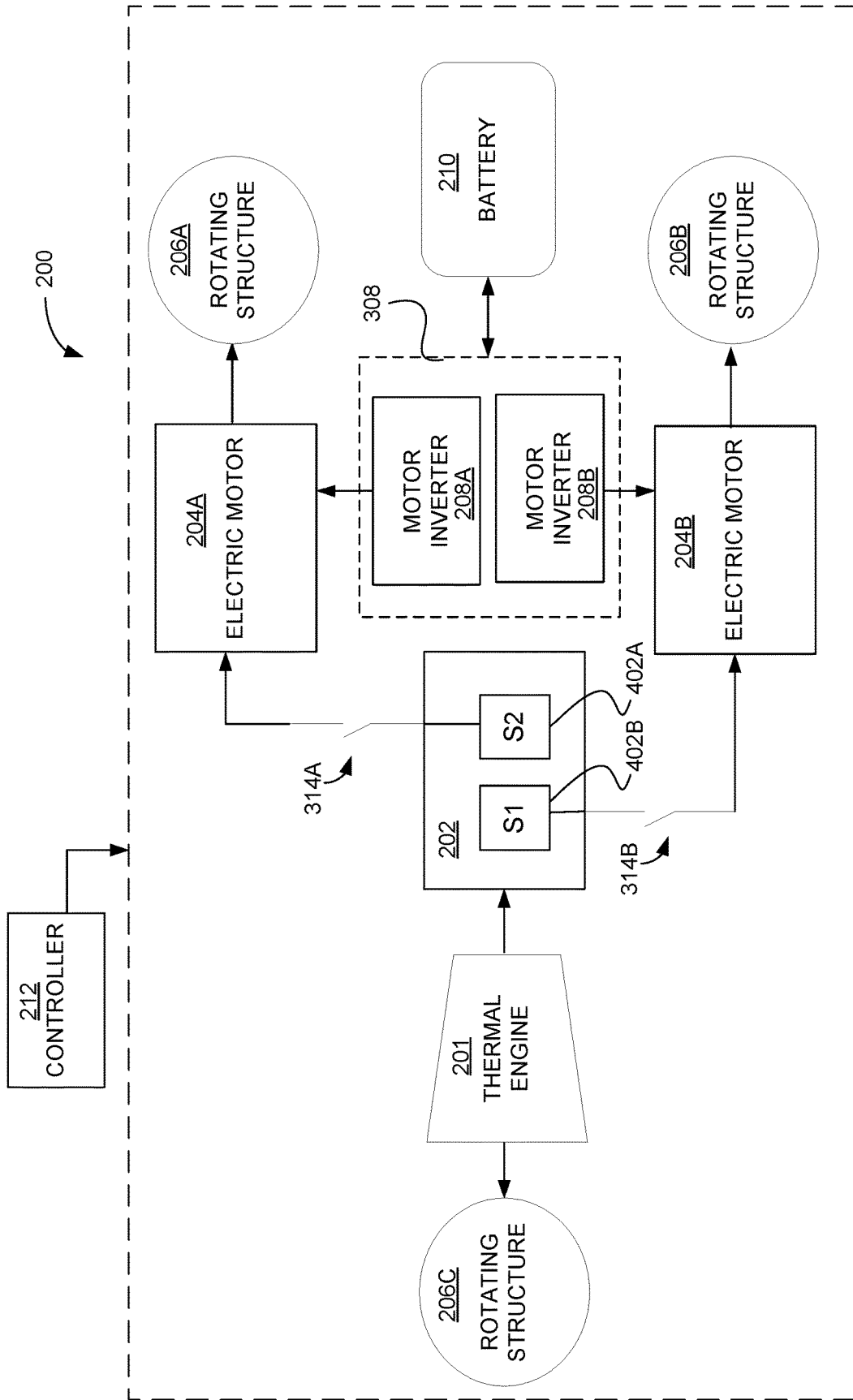

FIGURE 7

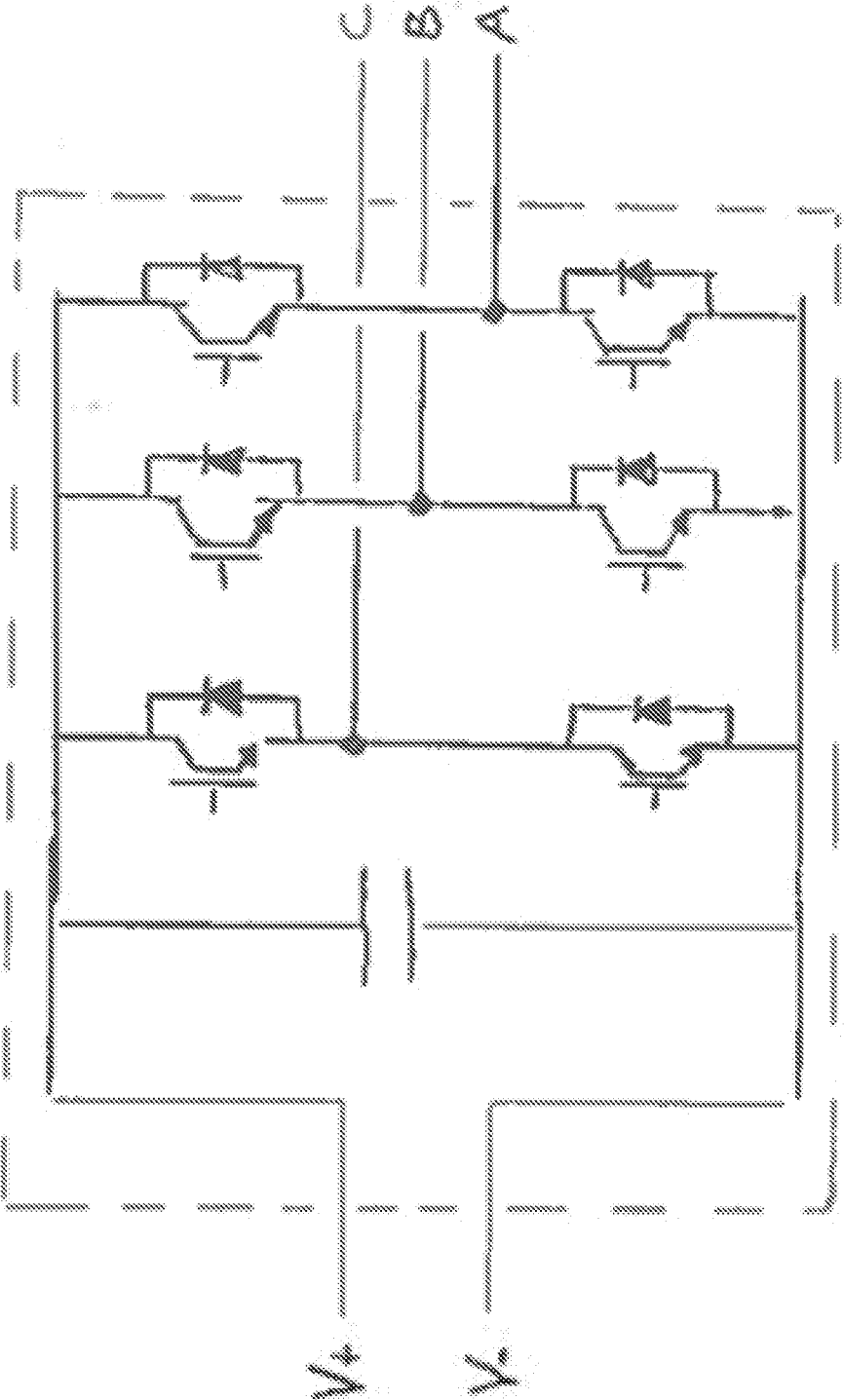

FIGURE 8

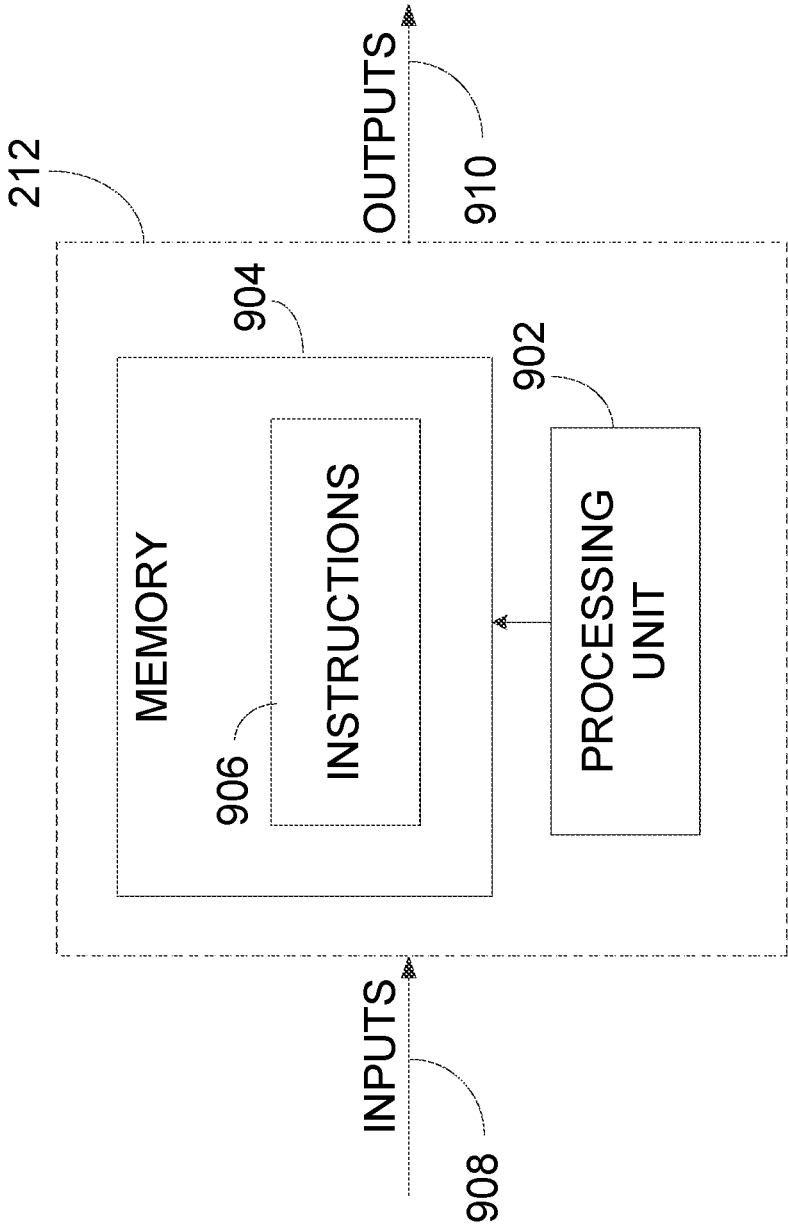

FIGURE 9

HYBRID ELECTRIC AIRCRAFT PROPULSION SYSTEM AND METHOD

CROSS-REFERENCE TO RELATED APPLICATIONS

[0001] The present application claims the benefit of U.S. Provisional Patent Application No. 62/727,673 filed on Sep. 6, 2018, U.S. Provisional Patent Application No. 62/727,678 filed on Sep. 6, 2018, U.S. Provisional Patent Application No. 62/727,681 filed on Sep. 6, 2018, U.S. Provisional Patent Application No. 62/727,683 filed on Sep. 6, 2018, U.S. Provisional Patent Application No. 62/729,818 filed on Sep. 11, 2018 and U.S. Provisional Patent Application No. 62/731,384 filed on Sep. 14, 2018, the contents of which are hereby incorporated by reference in their entirety.

TECHNICAL FIELD

[0002] The present disclosure relates generally to aircraft propulsion systems that use power from both an internal combustion engine and an electric motor.

BACKGROUND OF THE ART

[0003] Hybrid electric aircraft propulsion systems combine internal combustion and electric propulsion technologies. In an electric propulsion system, electrical energy is converted to rotational energy by an electric motor to drive a propulsion fan or a propeller.

[0004] There are environmental and cost benefits to having at least a portion of the power for an aircraft propulsion system come from electric motors. Therefore, there is a need for improvement to existing architectures.

SUMMARY

[0005] In accordance with a broad aspect, there is provided hybrid electric aircraft propulsion system. The system comprises a thermal engine configured for outputting rotational mechanical power, and a generator configured for generating a first source of alternating current (AC) electric power from the rotational mechanical power. The system comprises at least one motor inverter configured to convert DC electric power received from a DC power source to AC electric power to provide a second source of AC electric power, a first electric motor and a second electric motor operatively coupled to the generator to receive AC electric power therefrom and operatively coupled to the at least one motor inverter to receive AC electric power therefrom, the first electric motor configured to generate a first rotating output for driving a first rotating propulsor, the second electric motor configured to generate a second rotating output for driving a second rotating propulsor, and a controller configured for selectively driving the first and second electric motors from the generator, the at least one motor inverter, or a combination thereof.

[0006] In accordance with another broad aspect, there is provided a method for operating a hybrid electric aircraft propulsion system. The method comprises providing, to a first electric motor and a second electric motor, alternating current (AC) electric power from a generator, the generator receiving rotational power from a thermal engine, providing, to the first electric motor and the second electric motor, AC electric power from at least one motor inverter, the at least one motor inverter configured to convert DC electric power from a DC power source into AC electric power, and

selectively driving the first and second electric motors from the generator, the at least one motor inverter, or a combination thereof, wherein the first electric motor drives a first rotating propulsor and the second electric motor drives a second rotating propulsor.

[0007] Features of the systems, devices, and methods described herein may be used in various combinations, in accordance with the embodiments described herein.

BRIEF DESCRIPTION OF THE DRAWINGS

[0008] Reference is now made to the accompanying figures in which:

[0009] FIG. 1 is a schematic cross-sectional view of a gas turbine engine, in accordance with an illustrative embodiment;

[0010] FIG. 2 is a block diagram of a hybrid electric aircraft propulsion system, in accordance with an illustrative embodiment;

[0011] FIG. 3 is a block diagram of a hybrid electric aircraft propulsion system having two electric motors, in accordance with an illustrative embodiment;

[0012] FIG. 4 is a block diagram of a block diagram of a hybrid electric aircraft propulsion system having a dual stator generator, in accordance with an illustrative embodiment;

[0013] FIG. 5 is a block diagram of a hybrid electric aircraft propulsion system having dual stator electric motors, in accordance with an illustrative embodiment;

[0014] FIG. 6 is a block diagram of a hybrid electric aircraft propulsion system having selective connectivity, in accordance with an illustrative embodiment;

[0015] FIG. 7 is a block diagram of a hybrid electric aircraft propulsion system having additional propulsive power, in accordance with an illustrative embodiment;

[0016] FIG. 8 is an example of a motor inverter, in accordance with an illustrative embodiment;

[0017] FIG. 9 is a block diagram of an example controller, in accordance with an illustrative embodiment; and

[0018] It will be noted that throughout the appended drawings, like features are identified by like reference numerals.

DETAILED DESCRIPTION

[0019] There is described herein a hybrid electric aircraft propulsion system and method. The aircraft propulsion system uses power generated by a thermal engine and power generated by an electric generator. FIG. 1 illustrates an example thermal engine of a type preferably provided for use in subsonic flight, namely a gas turbine engine 10. The gas turbine engine 10 generally comprises in serial flow communication, a fan 12 through which ambient air is propelled, a compressor section 14 for pressurizing the air, a combustor 16 in which the compressed air is mixed with fuel and ignited for generating an annular stream of hot combustion gases, and a turbine section 18 for extracting energy from the combustion gases. High pressure rotor(s) 20 of the turbine section 18 are drivingly engaged to high pressure rotor(s) 22 of the compressor section 14 through a high pressure shaft 24. Low pressure rotor(s) 26 of the turbine section 18 are drivingly engaged to the fan rotor 12 and to other low pressure rotor(s) (not shown) of the

compressor section **14** through a low pressure shaft **28** extending within the high pressure shaft **24** and rotating independently therefrom.

[0020] Although illustrated as a turbofan engine, the gas turbine engine **10** may alternatively be another type of engine, for example a turboshaft engine, also generally comprising in serial flow communication a compressor section, a combustor, and a turbine section. A turboprop engine may also apply. In some embodiments, the thermal engine may be of a type other than a combustion engine, such as a piston engine or a rotary engine. In addition, although the engine **10** is described herein for flight applications, it should be understood that other uses, such as industrial or the like, may apply. Note that a constant volume combustion thermal machine, other than a piston or a rotary engine, may also be used.

[0021] Referring now to FIG. 2, there is illustrated an example embodiment for a hybrid electric aircraft propulsion system **200**. The system **200** presents an AC-AC architecture, whereby alternating current (AC) electric power is generated and applied directly to an electric motor. In an AC-DC-AC architecture, the AC electric power is converted to direct current (DC) and then reconverted to AC electric power to drive the electric motor. The AC-AC architecture is more efficient than the AC-DC-AC architecture as there are losses incurred during the conversion stages from AC to DC and from DC to AC.

[0022] Thermal engine **201** is operatively coupled to a generator **202**. The generator **202** receives motive power (or mechanical energy) from the thermal engine **201** and converts the motive power into electrical power. The generator **202** outputs alternating current (AC) electric power. The AC electric power is then provided directly to an electric motor **204**. The electric motor **204** converts the AC electric power into mechanical energy in the form of a rotary force. The rotary force is applied to a rotating structure **206** (i.e. a rotating propulsor), such as a propeller or a propulsion fan of an aircraft.

[0023] The electric motor **204** also receives AC electric power from a motor inverter **208**. The motor inverter **208** is operatively coupled to a battery **210** (or the aircraft electrical system). The battery **210** may be a dedicated battery provided for the hybrid electric aircraft propulsion system **200**. Alternatively, the electric power supplied to the inverter **208** may come from: an auxiliary power unit, a supplementary power unit, a backup power generator system, or the aircraft electrical system that does not include batteries or capacitors. The motor inverter **208** may thus be connected to the battery **210** via a battery bus on the aircraft, or via dedicated wiring and/or connectors. Any type of device containing one or more cells that convert chemical energy directly into electrical energy may be used as the battery **210**. In some embodiments, the battery **210** is based on a non-chemical principal, such as using the electricity of a supercapacitor in an energy storage mode.

[0024] The motor inverter **208** receives direct current (DC) electric power from the battery **210** (or another direct current source) and converts the DC voltage to AC voltage whose frequency and phase is adjusted to enable the motor **204** to generate mechanical power. The motor inverter **208** can also be used in the opposite sense to charge the battery **210** when the electric motor **204** is being driven by external machine forces, making it behave as a generator, in which condition the inverter can convert AC voltage back into DC

voltage. In some embodiments, the motor inverter **208** may also be used in a reverse mode, whereby AC electric power is converted to DC electric power.

[0025] The electric motor **204** therefore has a first input operatively coupled to the generator **202** to receive a first source of AC electric power. The electric motor **204** also has a second input operatively coupled to the motor inverter **208** to receive a second source of AC electric power. Note that the electric motor **204** does not need to have two independent inputs (i.e. one from the generator **202** and one from the inverter **208**). The output of the generator **202** and the output of the inverter **208** may be combined or connected in parallel before a motor input interface. The electric motor **204** will, in response to receiving either one of the first source of AC electric power and the second source of AC electric power (or both simultaneously), generate a rotating output for driving the rotating structure **206**.

[0026] A controller **212** is configured for selectively driving the electric motor **204** using the first source of AC electric power from the generator **202**, the second source of AC electric power from the motor inverter **208**, or a combination thereof. When AC electric power is received concurrently from both the generator **202** and the motor inverter **208**, a greater amount of power is available to the electric motor **204**. This in turn allows for a greater rotary force to be applied to the rotating structure **206**.

[0027] In some embodiments, the first source of AC electric power provided by the generator **202** is the primary source of propulsion power for the electric motor **204**. For example, under low power operating conditions, such as in cruise mode, all propulsive power for the rotating structure **206** may be provided by the generator **202**. Under high power operating conditions, such as in climb mode or take-off mode, a boost of propulsion power may be provided by the battery **210** through the motor inverter **208**. A secondary or additional source of electric power is thus available for the electric motor **204** through the motor inverter **208** in order to supplement the electric power provided by the generator **202**.

[0028] In some embodiments, the motor inverter **208** is sized to match the secondary power requirements of the electric motor **204**, i.e. the motor inverter **208** does not need to be a full-size motor inverter in order to drive the electric motor **204** on its own. In addition, there is no need for a generator converter to convert the voltage from AC to DC, since the electric power generated by the generator **202** is fed to the electric motor **204** without conversion. This architecture thus avoids the need for two stages of conversion during low power operating conditions. In some embodiments, the battery **210** is recharged directly from the motor inverter **208**.

[0029] In some embodiments, the motor inverter **208** is used to recover from or prevent desynchronization of the generator **202** and the electric motor **204**. When used for recovery of desynchronization, the motor inverter **208** may resynchronize the frequency of the electric motor **204** to the frequency of the generator **202**, in response to a command or control signal received from the controller **212**, or in response to logic implemented in the inverter **208** which monitors and seeks to control the frequency and phasing of the generator **202** and motor **204**. During resynchronization, the controller **212** may temporarily disconnect the generator **202** from the electric motor **204**, for example by opening a relay therebetween. The motor inverter **208** may then adjust

the power to the electric motor **204** so that the speed of the electric motor **204** is modified in such a way to match the frequency of the electric motor **204** to the frequency of the generator **202**. The electric motor **204** and the generator **202** can then be brought back in phase with each other. Once the electric motor **204** is back in phase with the generator **202**, the connection between the generator **202** and the electric motor **204** is restored.

[0030] When used for prevention of desynchronization, the motor inverter **208** may actively monitor the phase of the electric motor **204**. Upon detection of a mismatch in phase between the generator **202** and the electric motor **204**, for example in the case where the motor is slowed down by external forces, the motor inverter **208** may send an electric signal that is in-phase with the electric motor **204**, to provide additional power to bring the electric motor **204** back in phase with the generator **202**. This feature may be put into effect by the controller **212** or it can be incorporated in the inverter **208**.

[0031] In some embodiments, the motor inverter **208** is used to recharge the battery **210** or provide additional electrical power to the aircraft electrical systems that are connected to the inverter **208**. For example, the motor inverter **208** can increase the power demand on the generator **202**, such that the power produced by the generator exceeds the power required by the rotating structure **206** or load, and feed the excess power back to the battery **210** or aircraft electrical system. Alternatively, the motor inverter **208** can increase the power going to the electric motor **204** by feeding energy from the battery **210** to the electric motor **204**. This in turn increases the power available to the rotating structure **206**. The motor inverter **208** can either increase the available torque to the rotating structure **206** (ex: for a variable pitch propeller, additional torque may be required depending on the selected pitch of the propeller), or it can act as a generator to extract energy from a windmilling propeller by converting the AC voltage to a DC voltage that is higher than DC bus voltage in order to recharge the battery or feed electrical power back to the aircraft electrical system, if so desired. The inverter **208** has the ability to control the voltage on the DC bus, thereby controlling the power going to the DC bus.

[0032] Referring to FIG. 3, there is illustrated another example embodiment for a hybrid electric aircraft propulsion system **200**. In this example, two electric motors **204a**, **204b** are driven by the generator **202**. Each electric motor **204a**, **204b**, is associated with its own rotating structure **206a**, **206b**, respectively. Two motor inverters **208a**, **208b** are also provided, one to feed each one of the electric motors **204a**, **204b**, respectively. It should be understood that a single motor inverter **308** may also be used instead of two separate motor inverters **208a**, **208b**. The motor inverter **308** would then be sized for the power requirements of two electric motors **204a**, **204b** instead of just one of the electric motors **204a**, **204b**. In addition, the motor inverter **308** would need to be disconnected from electric motor **204a** in order to perform a resynchronization of electric motor **204b**, and disconnected from electric motor **204b** in order to perform a resynchronization of electric motor **204a**.

[0033] In some embodiments, the two motor inverters **208a**, **208b** are interconnected, in case of a failure of one of the two motor inverters **208a**, **208b**. For example, if one motor inverter **208a** fails, the other motor inverter **208b** may be used to charge the battery **210** or to drive the electric

motor **204a** associated with the failed motor inverter **208a**. This may also be achieved using a series of connections between the electric motors **204a**, **204b** and the motor inverters **208a**, **208b** to allow for selective connection and disconnection of the electric motors **204a**, **204b** to the motor inverters **208a**, **208b**.

[0034] In some embodiments, one or more relays **314a**, **314b** are provided in the interconnection path between the generator **202** and each one of the electric motors **204a**, **204b**, respectively. The relays **314a**, **314b** are an example embodiment for allowing selective connection and disconnection of the generator **202** to either one of the electric motors **204a**, **204b**. Other means of connection/disconnection may also be used.

[0035] The electric motors **204a**, **204b** may be provided on separate wings of an aircraft. Alternatively, they may be provided on a same wing of an aircraft. Also alternatively, one or both of the electric motors **204a**, **204b** may be provided in the nacelle or hub of a rotating propulsion device such as a propeller, fan, lift rotor or thruster, or in the hub of a contra-rotating propeller, fan rotor or thruster.

[0036] Three or more electric motors may be provided, whereby each electric motor **204** is associated with a motor inverter **208**. Alternatively, two or more motor inverters **208** may be combined to form a larger motor inverter **308** for all of the electric motors **204** or a subset thereof.

[0037] FIG. 4 illustrates yet another embodiment of the hybrid electric aircraft propulsion system **200**. In this example, the generator **202** is a dual stator generator, having a first generator stator **402a** driving one electric motor **204a** and a second generator stator **402b** driving the other electric motor **204b**. Note that this embodiment could also be applied to three or more sets of generator stators, motors and inverters. Two or more of the inverters **208** may be combined to form a larger motor inverter **308** for all the electric motors **204** or a subset thereof. In some embodiments, motor inverters **208a**, **208b** comprise a converter to perform the conversion from AC to DC to recharge the battery **210**. The electric motors **204a**, **204b** are driven independently from each other. Relays **314a**, **314b** may or may not be present in this embodiment, so as to allow a selective connection/disconnection of the generator **202** and the electric motors **204a**, **204b**.

[0038] FIG. 5 illustrates another example embodiment of the hybrid electric aircraft propulsion system **200**. In this example, one or more of the electric motors **204a**, **204b** have dual stators. The example illustrated shows electric motor **204a** having a first motor stator **502a** and a second motor stator **504a**, and electric motor **204b** having a first motor stator **502b**, and a second motor stator **504b**. Motor stator **502a** is operatively coupled to generator stator **402a**, and motor stator **502b** is operatively coupled to generator stator **402b**. Motor stator **504a** is operatively coupled to motor inverter **208a**, and motor stator **504b** is operatively coupled to motor inverter **208b**. In this configuration, the generator **202** does not share the same motor stator as the motor inverters **208a**, **208b**, thus resulting in the generator power and the motor inverter power being independent from one another. Should the motor inverter **208a** be used to recharge the battery **210**, stator **504b** would act as a motor while stator **504a** would act as a generator from which a conversion from AC to DC is required to recharge the battery **210**. Should the motor inverter **208b** be used to recharge the battery **210**, stator **504a** would act as a motor while stator **504b** would act

as a generator from which a conversion from AC to DC is required to recharge the battery 210.

[0039] Referring to FIG. 6, there is illustrated another embodiment of the hybrid electric aircraft propulsion system 200. In this example, additional connections are provided between the generator 202, the electric motors 204a, 204b, and the motor inverters 208a, 208b. Generator stator 402a may be selectively connected to both stators 502a, 504a of the electric motor 204a by closing relays 314a and 314c and opening relay 314d. Generator stator 402b may be selectively connected to both stators 502b, 504b of the electric motor 204b by closing relays 314b and 314e and opening relay 314f. Motor inverter 208a may be selectively connected to both stators 502a, 502b of the electric motor 204a by closing relays 314d and 314c and opening relay 314a. Motor inverter 208b may be selectively connected to both stators 502b, 504b of the electric motor 204b by closing relays 314f and 314e and opening relay 314b. Also, each stator 502a and/or 502b can be connected to both the generator stator 402a and the inverter 208A simultaneously, without opening relay 314a if so desired. This is useful to be able to use the inverters to either provide additional power or extract power to recharge batteries, or provide power to the aircraft DC bus, or to adjust and to maintain the motor and generator in phase with each other. Likewise for the other motor and associated generator stator, inverters, relays etc. This architecture provides the ability for the generator 202 to drive both stators 502a, 504a or 502b, 504b of either electric motor 204a, 204b, and for the motor inverters 208a, 208b, to drive both stators 502a, 504a or 502b, 504b of either electric motor 204a, 204b.

[0040] The architecture of FIG. 6 also provides the ability to recharge the battery 210 directly from the generator 202 by closing relays 314a, 314c, 314d and/or 314b, 314e, 314f, thereby providing a direct path between the generator 202 and the motor inverters 208a, 208b, respectively. In such a case, one or both of motor inverters 208a, 208b would need to be provided with an AC-DC converter to transform the AC power received by the generator 202 into DC power for the battery 210. The architecture of FIG. 6 also provides the ability for the battery to be used to provide mechanical power to the thermal engine, by driving the stator 402a or 402b as an electric motor instead of as a generator, if so desired, for example if this is useful to start the thermal engine or drive auxiliary systems such as pumps that are connected to the generator shaft before the engine is started. The same could be said of other embodiments.

[0041] Turning to FIG. 7, there is illustrated yet another embodiment of the hybrid electric aircraft propulsion system 200. In this example, a rotating structure 206c is operatively coupled to the thermal engine 201 so as to provide additional propulsion to the aircraft. Indeed, the motive power generated by the thermal engine 201 may also be applied directly to a rotating structure 206c such as a propeller or propulsion fan of the aircraft in order to supplement propulsion provided by rotating structures 206a, 206b.

[0042] It should be noted that while rotating structure 206c is illustrated in combination with the embodiment of FIG. 4, it may also be added to any of the other embodiments provided in FIGS. 2, 3, 5 and 6, as well as variants thereof. Variants thereof include, for example, a three-stator generator connected to three electric motors. It will be understood that the present embodiments apply to any number of generator stators and motor stators. Another example of a

variant to the present embodiments is a three stator electric motor, each stator connected to one of a generator stator, a first motor inverter, and a second motor inverter. The first and second motor inverters can be connected to a same battery or to separate batteries. Other variants will be readily understood by those skilled in the art.

[0043] In some embodiments, the various architectures for the hybrid electric aircraft propulsion system 200 are used to address possible failures within the system 200. Various examples of failure modes are described below.

[0044] Based on the embodiments of FIGS. 2 to 7, propulsion power for the rotating structure(s) 206 are available via the battery 210 in case of a failure of the thermal engine 201. The available power is however limited by the power & energy capacity of the battery 210 (or aircraft DC bus) and the power rating of the motor inverter(s) 208, 208a, 208b, 308. Similarly, in the case of a generator failure due to a short circuit, propulsion power for the rotating structure(s) 206, 206a, 206b is available via the battery 210, but limited by the capacity of the battery 210 and the power rating of the motor inverter(s) 208, 208a, 208b, 308. In the case of a battery failure, propulsion power is available but limited by the power of the generator 202 and the available fuel for the thermal engine 201.

[0045] Based on the embodiments of FIGS. 3 to 7 where there are at least two electric motors 204a, 204b, in the case of a failure to one electric motor 204a, full power is available to the other functional electric motor 204b. In the case of a failure to one motor inverter 208a, full power is available to one electric motor 204b and partial power is available to the other electric motor 204a, limited by the power of the generator 202 and the available fuel for the thermal engine 201. If the two motor inverters 208a, 208b are connected together, then full power may be available to either electric motor 204a, 204b.

[0046] Based on the embodiments of FIGS. 4 to 7 where the generator 202 has dual stators 402, 404, in the case of a generator failure due to an open-circuit on one of the two stators 402, 404, full power is available to one of the two electric motors 204a, 204b. Partial power is available to the other one of the two electric motors 204a, 204b, limited by the power and capacity of the battery 210 and the power rating of the motor inverter 208a, 208b associated thereto. In addition, in case of battery depletion, energy from the functioning generator stator can be transferred to the opposite motor through the two motor inverters.

[0047] Based on the embodiment of FIG. 5 where each electric motor 204a, 204b has two stators, in the case of a failure to one stator 502a or 504a, some power is still available from the electric motor 204a. If the failure is to stator 502a, power is still available from the battery 210 and is limited by the capacity of the battery 210 and the power rating of the motor inverter 208a associated thereto and the power rating of the remaining motor stator 504a. If the failure is to stator 504a, power is still available from the generator 202 and is limited by the power of the generator 202 and the available fuel for the thermal engine 201 and the power rating of the remaining motor stator 502a.

[0048] Based on the embodiment of FIG. 6, if an inverter 208a or 208b fails, full power is still available for the associated electric motor 204a or 204b from the generator stator 402a or 402b with proper relay configuration, limited by generator rating. Similarly, if a generator stator 402a or 402b fails, both motor stators of the associated electric

motor **204a** or **204b** may be powered by the battery **210**. The total power available would then depend on the rating of the inverter **208a** or **208b** and of the battery **210**.

[0049] Based on the embodiment of FIG. 7, if both electric motors **204a**, **204b** fail and the aircraft is out of fuel, power from the battery can be transferred to the main shaft of the thermal engine **201** to produce propulsion power for the rotating structure **206c**. The motor inverters **208a**, **208b** may be connected to the generator **202** to act as a motor and add power to the rotating structure **206C** and other devices such as pumps that might also be mechanically connected to the rotating structure. If all electric systems fail, the thermal engine **201** can still provide propulsion power for the rotating structure **206c**.

[0050] FIG. 8 is an example embodiment of a motor inverter **208**. There is illustrated one of many possible embodiments that can be used with the hybrid electric aircraft propulsion system **200** described herein. Lines V+ and V- are connected to the positive and negative terminals of the battery **210**. Lines A, B, C are connected to an electric motor **204**, and represent the three phases of the AC electric power provided thereto.

[0051] With reference to FIG. 9, there is illustrated an example embodiment of controller **212**, comprising a processing unit **902** and a memory **904** which has stored therein computer-executable instructions **906**. FIG. 9 may also represent a control function embedded in the inverter **208**. The processing unit **902** may comprise any suitable devices configured to implement the system such that instructions **906**, when executed by the controller **212** or other programmable apparatus, may cause the functions/acts/steps as described herein to be executed. The processing unit **902** may comprise, for example, any type of general-purpose microprocessor or microcontroller, a digital signal processing (DSP) processor, a central processing unit (CPU), an integrated circuit, a field programmable gate array (FPGA), a reconfigurable processor, other suitably programmed or programmable logic circuits, or any combination thereof.

[0052] The memory **904** may comprise any suitable known or other machine-readable storage medium. The memory **904** may comprise non-transitory computer readable storage medium, for example, but not limited to, an electronic, magnetic, optical, electromagnetic, infrared, or semiconductor system, apparatus, or device, or any suitable combination of the foregoing. The memory **904** may include a suitable combination of any type of computer memory that is located either internally or externally to the controller **212**, for example random-access memory (RAM), read-only memory (ROM), compact disc read-only memory (CDROM), electro-optical memory, magneto-optical memory, erasable programmable read-only memory (EPROM), and electrically-erasable programmable read-only memory (EEPROM), Ferroelectric RAM (FRAM) or the like. Memory **904** may comprise any storage means (e.g., devices) suitable for retrievably storing machine-readable instructions **906** executable by processing unit **902**. Note that the controller **212** can be implemented as part of a full-authority digital engine controls (FADEC) or other similar device, including electronic engine control (EEC), engine control unit (EUC), and the like.

[0053] The methods and systems described herein may be implemented in a high level procedural or object oriented programming or scripting language, or a combination thereof, to communicate with or assist in the operation of a

computer system, for example the controller **212**. Alternatively, the methods and systems may be implemented in assembly or machine language. The language may be a compiled or interpreted language. Program code for implementing the methods and systems may be stored on a storage media or a device, for example a ROM, a magnetic disk, an optical disc, a flash drive, or any other suitable storage media or device. The program code may be readable by a general or special-purpose programmable computer for configuring and operating the computer when the storage media or device is read by the computer to perform the procedures described herein. Embodiments of the methods and systems may also be considered to be implemented by way of a non-transitory computer-readable storage medium having a computer program stored thereon. The computer program may comprise computer-readable instructions which cause a computer, or in some embodiments the processing unit **902** of the controller **212**, to operate in a specific and predefined manner to perform the functions described herein.

[0054] Computer-executable instructions may be in many forms, including program modules, executed by one or more computers or other devices. Generally, program modules include routines, programs, objects, components, data structures, etc., that perform particular tasks or implement particular abstract data types. Typically the functionality of the program modules may be combined or distributed as desired in various embodiments.

[0055] The above description is meant to be exemplary only, and one skilled in the art will recognize that changes may be made to the embodiments described without departing from the scope of the invention disclosed. Still other modifications which fall within the scope of the present invention will be apparent to those skilled in the art, in light of a review of this disclosure.

[0056] Various aspects of the systems and methods described herein may be used alone, in combination, or in a variety of arrangements not specifically discussed in the embodiments described in the foregoing and is therefore not limited in its application to the details and arrangement of components set forth in the foregoing description or illustrated in the drawings. For example, aspects described in one embodiment may be combined in any manner with aspects described in other embodiments. Although particular embodiments have been shown and described, it will be apparent to those skilled in the art that changes and modifications may be made without departing from this invention in its broader aspects. The scope of the following claims should not be limited by the embodiments set forth in the examples, but should be given the broadest reasonable interpretation consistent with the description as a whole.

1. A hybrid electric aircraft propulsion system, the system comprising:

- a thermal engine configured for outputting rotational mechanical power;
- a generator configured for generating a first source of alternating current (AC) electric power from the rotational mechanical power;
- at least one motor inverter configured to convert DC electric power received from a DC power source to AC electric power to provide a second source of AC electric power;
- a first electric motor and a second electric motor operatively coupled to the generator to receive AC electric power therefrom and operatively coupled to the at least

one motor inverter to receive AC electric power therefrom, the first electric motor configured to generate a first rotating output for driving a first rotating propulsor, the second electric motor configured to generate a second rotating output for driving a second rotating propulsor; and

a controller configured for selectively driving the first and second electric motors from the generator, the at least one motor inverter, or a combination thereof.

2. The system of claim 1, wherein the controller is configured for selectively connecting the generator to the first electric motor or the second electric motor.

3. The system of claim 2, wherein the generator comprises a first generator stator and a second generator stator, and wherein the first generator stator drives the first electric motor and the second generator stator drives the second electric motor.

4. The system of claim 3, wherein the at least one motor inverter comprises a first motor inverter operatively coupled to the first electric motor and a second motor inverter operatively coupled to the second electric motor.

5. The system of claim 4, wherein at least one of the first electric motor and the second electric motor comprises a first motor stator and a second motor stator, and wherein the first motor stator is operatively coupled to the generator and the second motor stator is operatively coupled to the at least one motor inverter.

6. The system of claim 5, wherein the at least one motor inverter is selectively connected to the first motor stator and the second motor stator, and the generator is selectively connected to the first motor stator and the second motor stator.

7. The system of claim 6, wherein the controller is configured to perform any one of:

- driving the first motor stator, the second motor stator or both from the generator; and
- driving the first motor stator, the second motor stator, or both, from the at least one motor inverter.

8. The system of claim 1, wherein the generator and the at least one motor inverter are selectively coupled together, and the controller is configured to charge the DC power source using the AC electric power through the at least one motor inverter.

9. A method for operating a hybrid electric aircraft propulsion system, the method comprising:

- providing, to a first electric motor and a second electric motor, alternating current (AC) electric power from a generator, the generator receiving rotational power from a thermal engine;
- providing, to the first electric motor and the second electric motor, AC electric power from at least one motor inverter, the at least one motor inverter configured to convert DC electric power from a DC power source into AC electric power; and
- selectively driving the first and second electric motors from the generator, the at least one motor inverter, or a combination thereof, wherein the first electric motor

drives a first rotating propulsor and the second electric motor drives a second rotating propulsor.

10. The method of claim 9, wherein providing AC electric power from a generator comprises providing AC electric power to the first electric motor from a first stator of the generator and providing AC electric power to the second electric motor from a second stator of the generator.

11. The method of claim 10, wherein providing AC electric power to the first electric motor from a first stator of the generator comprises providing AC electric power from the first stator of the generator to a first stator of the first electric motor, and wherein providing AC electric power from at least one motor inverter comprises providing AC electric power from the at least one motor inverter to a second stator of the first electric motor.

12. The method of claim 11, wherein providing AC electric power from at least one motor inverter comprises providing AC electric power from a first motor inverter to the first electric motor and providing AC electric power from a second motor inverter to the second electric motor.

13. The method of claim 11, further comprising:

- selectively connecting the generator to the at least one motor inverter and disconnecting the generator from the first electric motor or second electric motor; and
- charging the DC power source using AC electric power through the at least one motor inverter.

14. The method of claim 11, wherein selectively driving the first electric motor comprises:

- selectively connecting the generator to the first stator and the second stator of the first electric motor and disconnecting the second stator of the first electric motor from the at least one motor inverter; and
- driving the first stator and the second stator of the first electric motor with the generator.

15. The method of claim 11, wherein selectively driving the first electric motor comprises:

- selectively connecting the at least one motor inverter to the first stator and the second stator of the first electric motor and disconnecting the first stator of the first electric motor from the generator; and
- driving the first stator and the second stator of the first electric motor with the at least one motor inverter.

16. The method of claim 11, wherein selectively driving the first electric motor comprises:

- driving at least one of the first stator of the first electric motor and the second stator of the first electric motor from the generator; and
- driving at least one of the first stator of the first electric motor and the second stator of the first electric motor from the at least one motor inverter.

17. The method of claim 9, further comprising:

- driving a third rotating propulsor using propulsion power generated by the thermal engine.

18. The method of claim 9, further comprising charging the DC power source using AC electric power through the at least one motor inverter.

* * * * *