



US 20230023830A1

(19) **United States**

(12) **Patent Application Publication**
TAURINO

(10) **Pub. No.: US 2023/0023830 A1**

(43) **Pub. Date: Jan. 26, 2023**

(54) **A FORMULATION FOR USE IN AN AEROSOL-GENERATING SYSTEM**

Publication Classification

(71) Applicant: **Philip Morris Products S.A.**,
Neuchatel (CH)

(51) **Int. Cl.**
A24B 15/167 (2006.01)
A24F 40/10 (2006.01)
A24B 15/30 (2006.01)

(72) Inventor: **Irene TAURINO**, Neuchatel (CH)

(52) **U.S. Cl.**
CPC *A24B 15/167* (2016.11); *A24F 40/10*
(2020.01); *A24B 15/30* (2013.01)

(73) Assignee: **Philip Morris Products S.A.**,
Neuchatel (CH)

(21) Appl. No.: **17/785,861**

(57) **ABSTRACT**

(22) PCT Filed: **Dec. 16, 2020**

(86) PCT No.: **PCT/EP2020/086572**

§ 371 (c)(1),

(2) Date: **Jun. 15, 2022**

A formulation for an aerosol-generating system is provided, the formulation including: one or more aerosol formers; one or more metal salts; and one or more polymeric thickening agents, in which the formulation has a polymeric thickening agent content of greater than or equal to about 0.5 percent by weight, and in which the one or more metal salts include one or more metal stearates. An aerosol-generating article for the aerosol-generating system, and an aerosol-generating system, are also provided.

(30) **Foreign Application Priority Data**

Dec. 18, 2019 (EP) 19217716.0

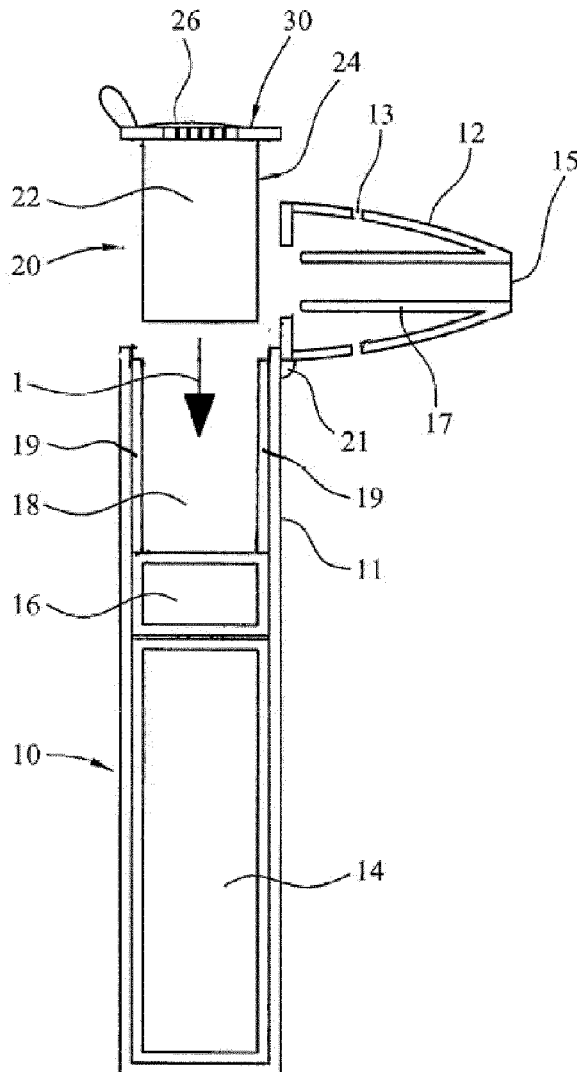

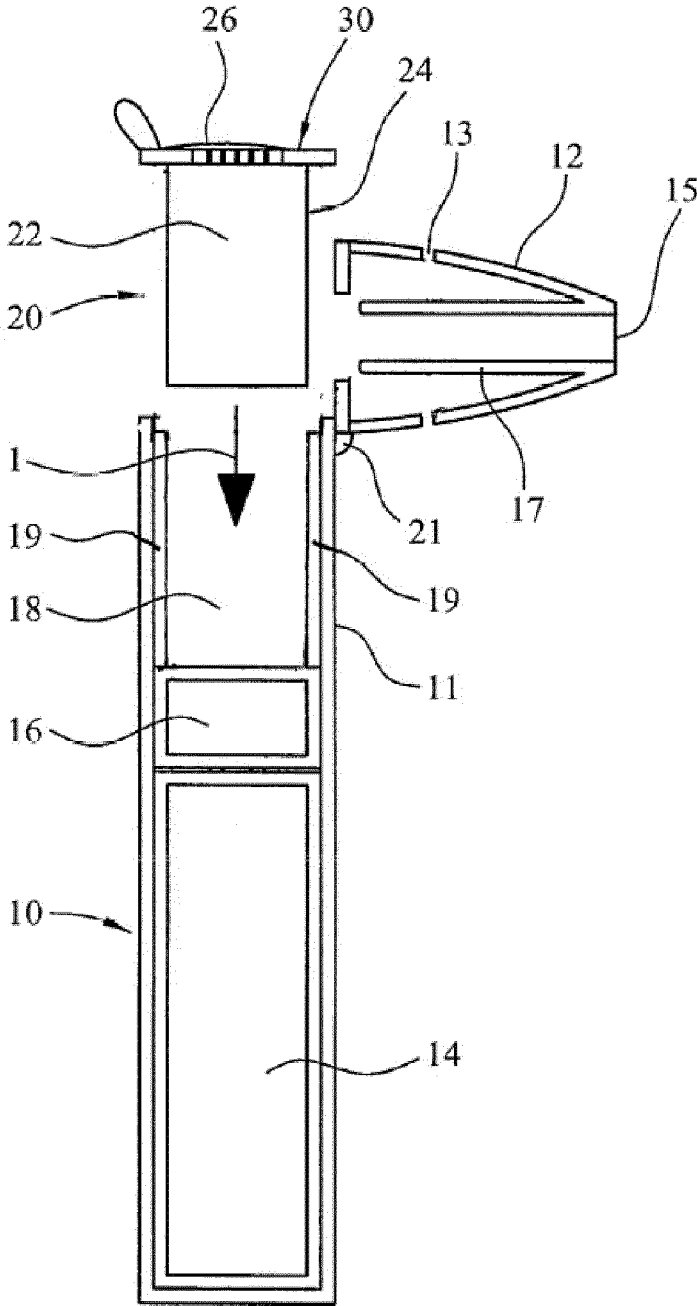

Figure 1

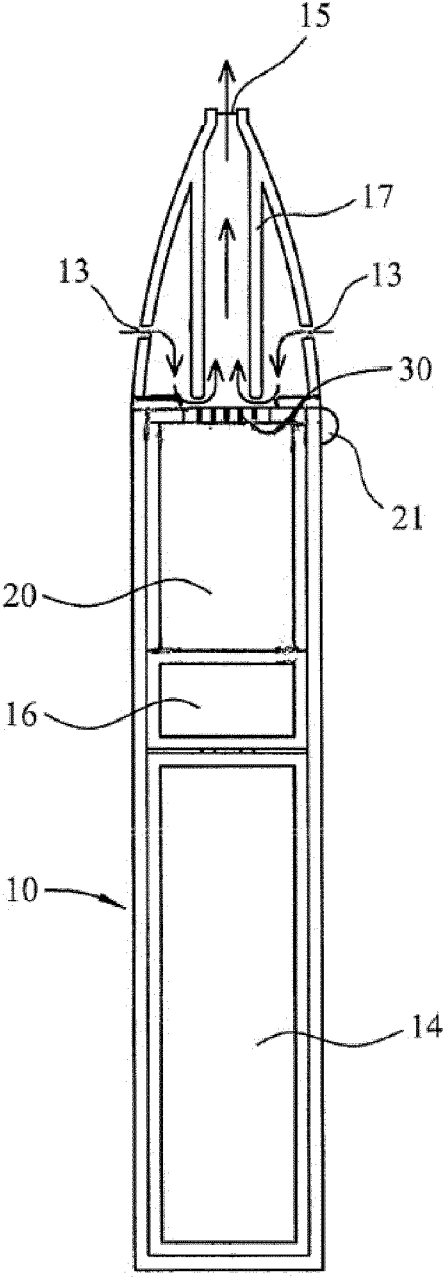

Figure 2

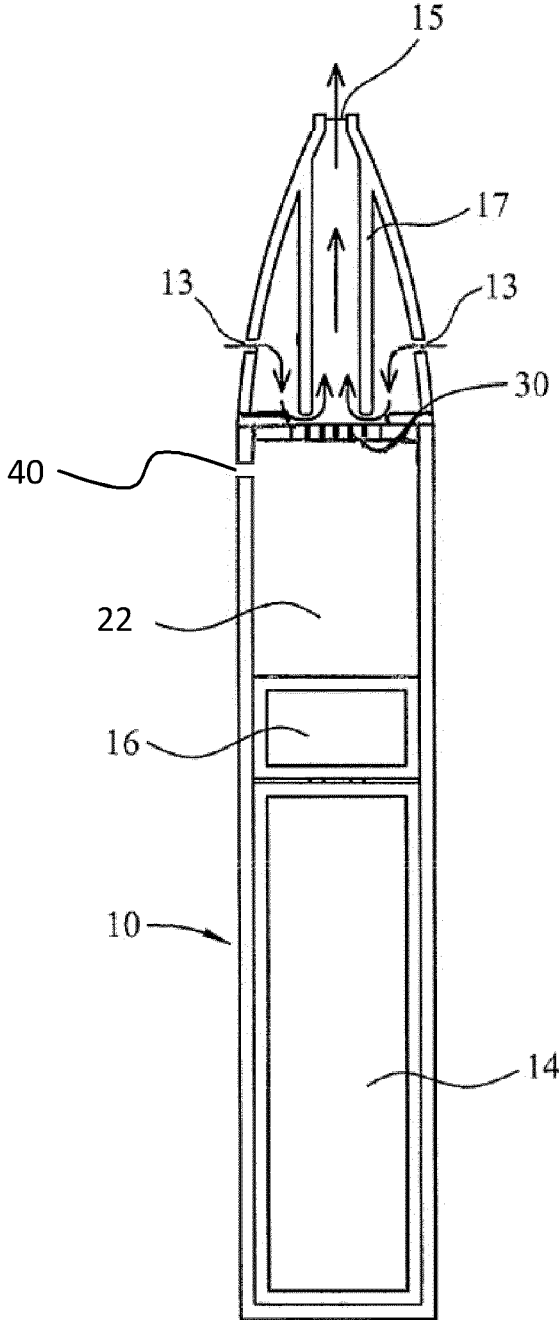

Figure 3

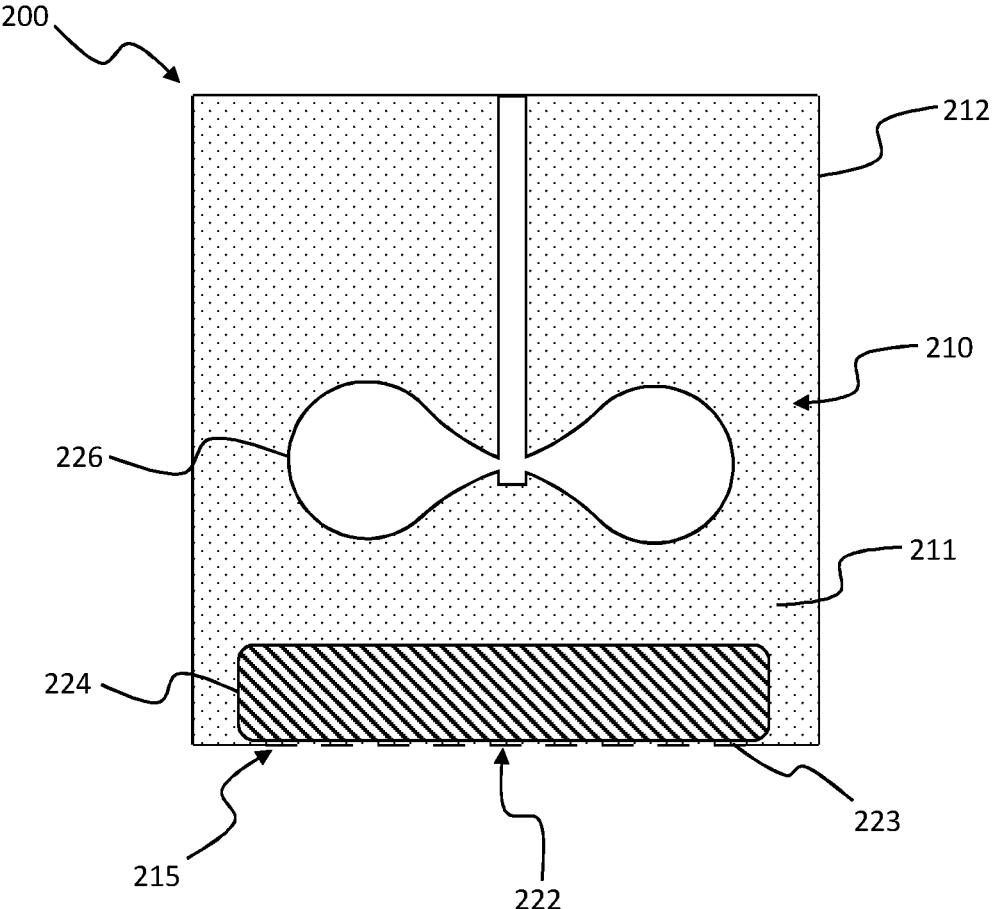

Figure 4

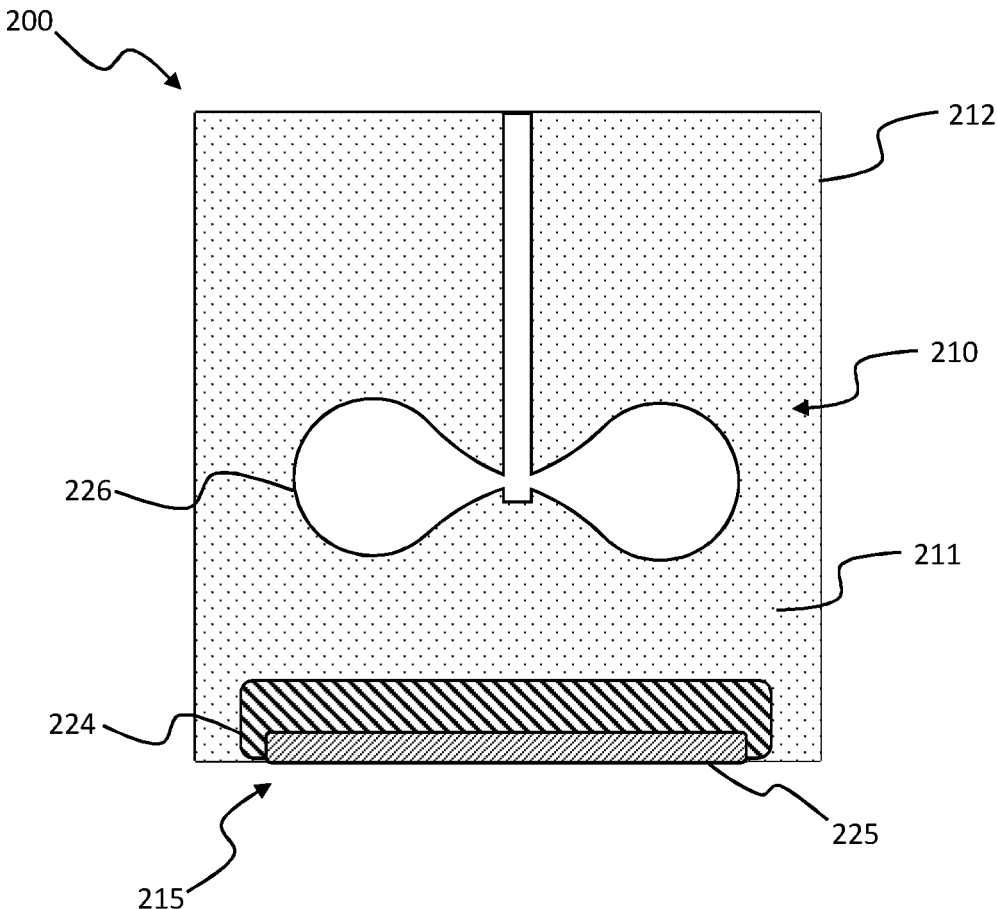

Figure 5

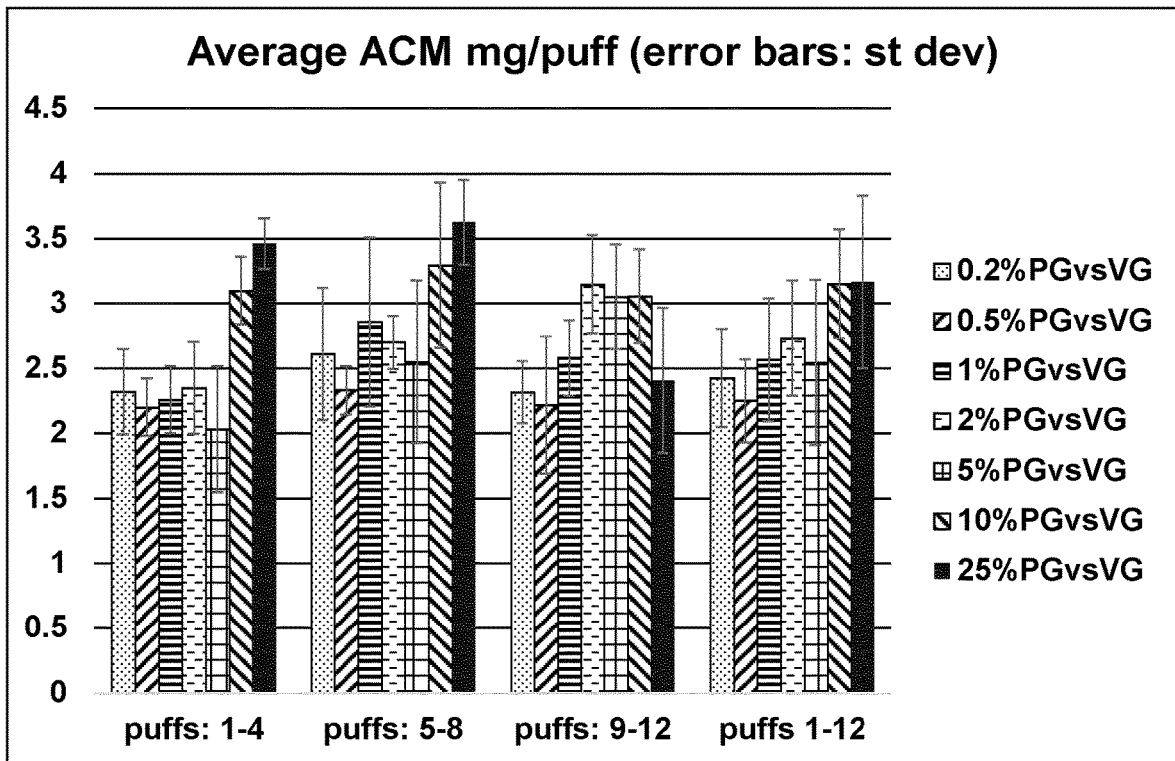

Figure 6

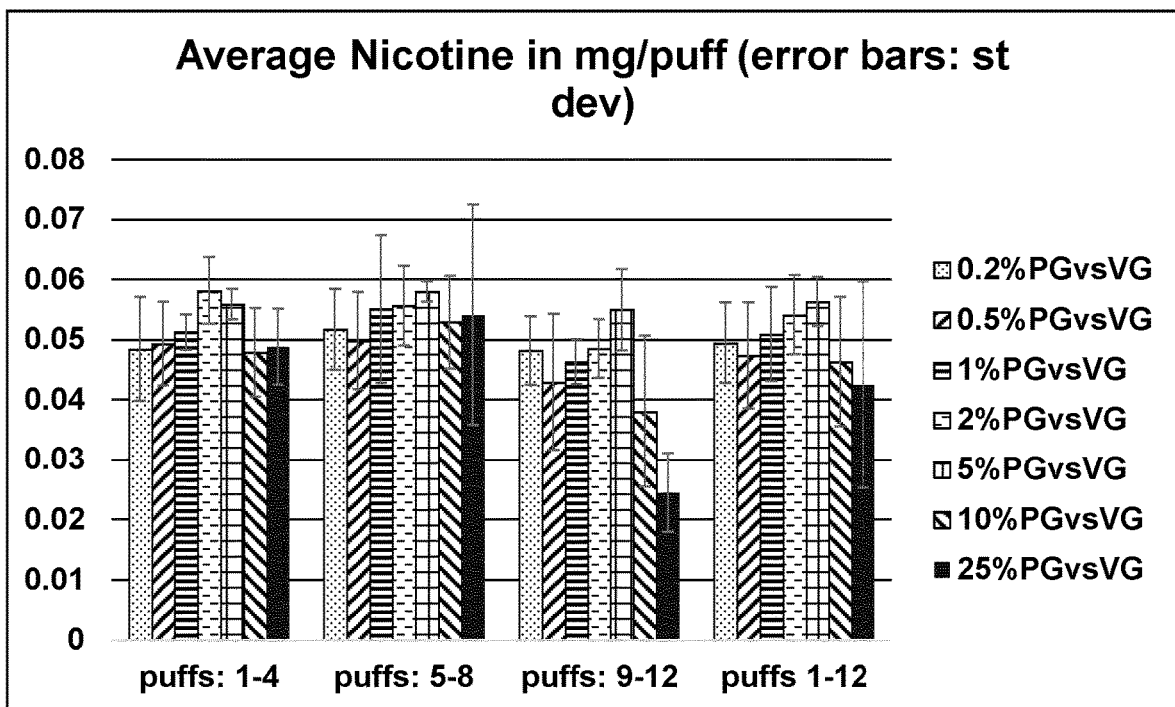

Figure 7

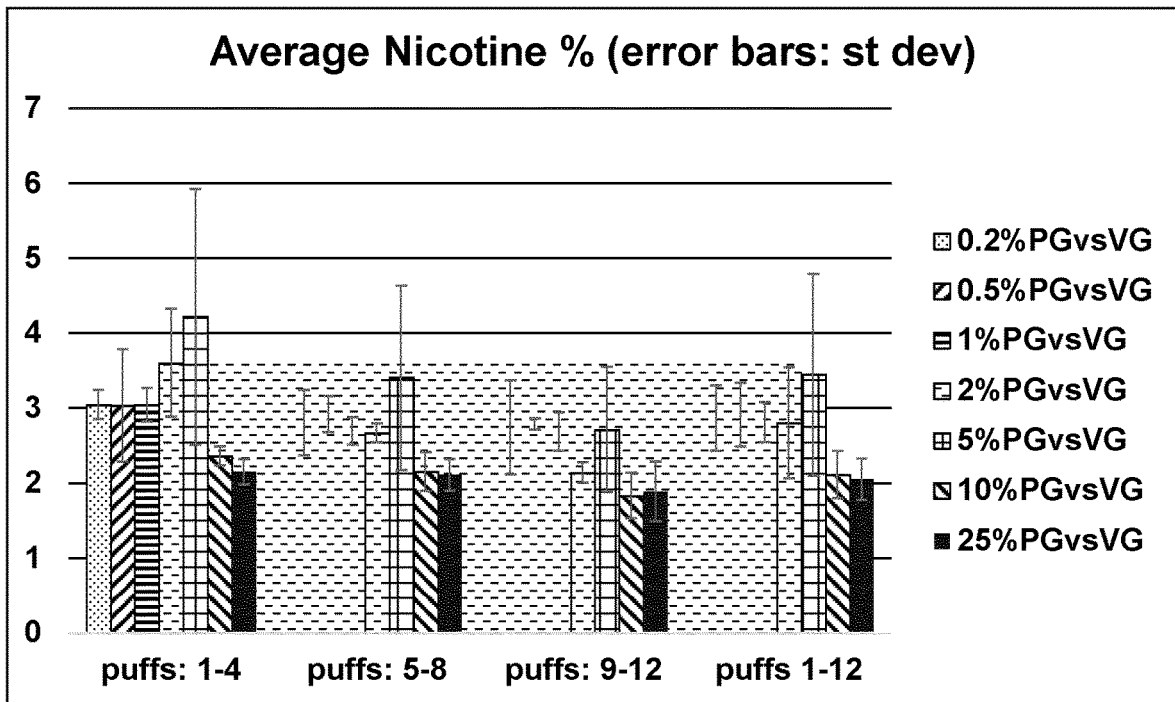

Figure 8

A FORMULATION FOR USE IN AN AEROSOL-GENERATING SYSTEM

[0001] The present invention relates to a formulation for use in an aerosol-generating system. The invention also relates to an aerosol-generating article comprising the formulation for use in an aerosol-generating system, and an aerosol-generating system comprising the formulation and an atomiser.

[0002] Aerosol-generating systems for delivering an aerosol to a user typically comprise an atomiser configured to generate an inhalable aerosol from a formulation. Some known aerosol-generating systems comprise a thermal atomiser such as an electric heater that is configured to heat and vaporise the formulation to generate an aerosol. Typical formulations for use in aerosol-generating systems are nicotine formulations, which may be liquid nicotine formulations comprising an aerosol former such as glycerine and/or propylene glycol.

[0003] It would be desirable to provide a formulation that exhibits reduced risk of leakage compared to typical formulations when used in an aerosol-generating system.

[0004] There is provided a formulation for use in an aerosol-generating system. The formulation may comprise one or more aerosol formers. The formulation may comprise one or more polymeric thickening agents. The formulation may have a polymeric thickening agent content of greater than or equal to about 0.5 percent by weight.

[0005] There is also provided a formulation for use in an aerosol-generating system, the formulation comprising: one or more aerosol formers; and one or more polymeric thickening agents, wherein the formulation has a polymeric thickening agent content of greater than or equal to about 0.5 percent by weight.

[0006] There is also provided an aerosol-generating article for use in an aerosol-generating system, the aerosol-generating article containing a formulation comprising: one or more aerosol formers; and one or more polymeric thickening agents, wherein the formulation has a polymeric thickening agent content of greater than or equal to about 0.5 percent by weight.

[0007] There is also provided an aerosol-generating device comprising: a formulation comprising: one or more aerosol formers; and one or more polymeric thickening agents, wherein the formulation has a polymeric thickening agent content of greater than or equal to about 0.5 percent by weight.

[0008] There is also provided an aerosol-generating system comprising: a formulation comprising: one or more aerosol formers; and one or more polymeric thickening agents, wherein the formulation has a polymeric thickening agent content of greater than or equal to about 0.5 percent by weight; and an atomiser configured to generate an aerosol from the formulation.

[0009] As used herein, the term “aerosol-forming substrate” relates to a substrate capable of releasing volatile compounds that can form an aerosol. Such volatile compounds may be released by heating the aerosol-forming substrate or by other aerosolising means. The aerosol-forming substrate may be a liquid. The liquid may be an e-liquid. The liquid may be a solution. The liquid may be a colloid. The colloid may have discontinuous solid particles dispersed in a continuous liquid. The colloid may have discontinuous liquid particles dispersed in a continuous

liquid. The colloid may have discontinuous liquid particles dispersed in a continuous solid.

[0010] Unless stated otherwise, percentages by weight of components of the formulation recited herein are based on the total weight of the formulation.

[0011] Advantageously, the formulation provides a way of internally sealing a reservoir of an aerosol-generating system containing the formulation by forming a barrier after each use of the aerosol-generating system. The formulation may be initially provided as a liquid in a reservoir of an aerosol-generating system. The formulation may be heated to form an aerosol as with a typical aerosol-generating system. When the formulation cools after being heated, at least a portion of the formulation in the region of the heater may solidify to form a solid layer. The resulting solid layer may cover the entire opening of the reservoir. The solid layer may act as a barrier, which seals the reservoir. Sealing the reservoir in this way may advantageously reduce the risk of leakage of the formulation from the reservoir.

[0012] Sealing the reservoir in this way may advantageously prevent flooding of the aerosol-generating system due to formulation seeping out of reservoir between uses of the aerosol-generating system.

[0013] The solid layer may advantageously be melted or vaporised by a heater of the aerosol-generating system. The solid layer may then reform as the formulation cools or after the formulation has cooled between each use, thereby re-sealing the reservoir and again preventing leakage of the formulation from the reservoir. Vaporisation of the solid layer in this way may allow repeated use of the aerosol-generating system.

[0014] The one or more polymeric thickening agents may be selected from the group consisting of: polyvinyl acetate (PVA), polyvinyl alcohol (PVOH), polyethylene glycol (PEG), polyglycolic acid (PGA), polylactic acid (PLA), polydioxanone (PDO), polycaprolactone (PCL), polyethylene (PE), polypropylene glycol (PPG) and starch.

[0015] All starches are made up from varying proportions of amylose and amylopectin. The selection of the particular starch for the formulation may be based on the ratio of amylose to amylopectin, which depends on the desired function of the starch. The starch may be corn starch or wheat starch. Preferably, the starch is corn starch, preferably the starch is waxy corn starch. Waxy corn starch is essentially pure amylopectin containing only trace amounts of amylose. Waxy corn starches have been found to produce a better, more elastic barrier. It should be noted that the molecular weight of the starch varies due to natural variation.

[0016] Preferably, when the polymeric thickening agent is polyethylene, the polyethylene is low density polyethylene.

[0017] Preferably, the one or more polymeric thickening agents are selected from the group consisting of: polyvinyl alcohol, polyethylene glycol, polypropylene glycol and starch.

[0018] More preferably, the one or more polymeric thickening agents are selected from the group consisting of: polyvinyl alcohol, polyethylene glycol and polypropylene glycol.

[0019] Even more preferably, the one or more polymeric thickening agents are selected from the group consisting of: polyvinyl alcohol and polyethylene glycol.

[0020] Most preferably, the one or more polymeric thickening agents consists of polyvinyl alcohol.

200000 g/mol. The one or more polymeric thickening agents may have a weight average molecular weight of between 140000 g/mol and 190000 g/mol.

[0030] The formulation may comprise one or more metal salts.

[0031] Bonding between the one or more metal salts and the one or more aerosol formers in the formulation may elevate the boiling point of the one or more aerosol formers. When the formulation includes nicotine, this may advantageously enhance the efficiency of vaporisation of nicotine from the formulation when used in an aerosol-generating system as compared to a typical liquid nicotine formulation that does not include one or more metal salts.

[0032] The one or more metal salts may be selected from the group consisting of metal alginates, metal benzoates, metal cinnamates, metal cycloheptanecarboxylates, metal levulinates, metal propanoates, metal stearates and metal undecanoates.

[0033] Preferably the one or more metal salts are selected from the group consisting of metal cinnamates, metal cycloheptanecarboxylates, metal levulinates, metal propanoates, metal stearates and metal undecanoates.

[0034] Preferably the one or more metal salts are selected from the group consisting of metal benzoates, metal cinnamates, metal cycloheptanecarboxylates, metal levulinates, metal propanoates, metal stearates and metal undecanoates.

[0035] Preferably the one or more metal salts are selected from the group consisting of metal cinnamates, metal cycloheptanecarboxylates, metal stearates and metal undecanoates.

[0036] The one or more salts may be salts of any suitable metal.

[0037] Preferably, the one or more metal salts are alkali metal salts.

[0038] More preferably, the one or more metal salts are sodium salts.

[0039] Preferably, the vaporisable barrier comprises one or more non-saccharide sodium salts. Preferably, the one or more metal salts comprise one or more non-saccharide sodium salts.

[0040] The one or more metal stearates may comprise sodium stearate.

[0041] A metal salt with a high molecular weight may improve the above mentioned advantages related to efficiency of vaporisation of nicotine and speed of formation of the solid layer. However, if the molecular weight of a metal salt is too high then properties such as solubility begin to be negatively affected. Advantageously, including sodium stearate in the formulation may provide an optimal balance in improved efficiency of vaporisation of nicotine and speed of formation of the solid layer, whilst maintaining solubility.

[0042] More preferably, the one or more sodium salts are selected from the group consisting of sodium benzoate, sodium cinnamate, sodium cycloheptanecarboxylate, sodium levulinate, sodium propanoate, sodium stearate and sodium undecanoate.

[0043] Preferably the one or more metal salts are selected from the group consisting of sodium cinnamates, sodium cycloheptanecarboxylates, sodium levulinates, sodium propanoates, sodium stearates and sodium undecanoates.

[0044] Preferably the one or more sodium salts are selected from the group consisting of sodium benzoates,

sodium cinnamates, sodium cycloheptanecarboxylates, sodium levulinates, sodium propanoates, sodium stearates and sodium undecanoates.

[0045] Preferably the one or more metal salts are selected from the group consisting of sodium cinnamates, sodium cycloheptanecarboxylates, sodium stearates and sodium undecanoates.

[0046] Most preferably, the one or more metal salts is sodium stearate.

[0047] Advantageously, inclusion of one or more metal stearates in the formulation may increase the speed of formation of the solid layer. In a specific example, advantageously, a formulation including a combination of a metal stearate and glycerine generates a harder solid layer.

[0048] Advantageously, covalent bonding between the one or more metal stearates and the one or more aerosol formers in the formulation may further elevate the boiling point of the one or more aerosol formers. When the formulation includes nicotine, this may advantageously enhance the efficiency of vaporisation of nicotine from the formulation when used in an aerosol-generating system as compared to a typical liquid nicotine formulation that does not include one or more metal stearates.

[0049] The formulation may have a metal salt content of greater than or equal to about 0.5 percent by weight. The formulation may have a metal salt content of greater than or equal to about 0.75 percent by weight. The formulation may have a metal salt content of greater than or equal to about 1 percent by weight. The formulation may have a metal salt content of greater than or equal to about 1.5 percent by weight. The formulation may have a metal salt content of greater than or equal to about 2 percent by weight.

[0050] The formulation may have a metal salt content of less than or equal to about 10 percent by weight. For example, the formulation may have a metal salt content of less than or equal to about 5 percent by weight. The formulation may have a metal salt content of less than or equal to about 2 percent by weight.

[0051] The formulation may have a metal salt content of between about 0.5 percent by weight and about 10 percent by weight. For example, the formulation may have a metal salt content of between about 0.5 percent by weight and about 5 percent by weight. The formulation may have a metal salt content of between about 0.5 percent by weight and about 2 percent by weight.

[0052] The formulation may have a metal salt content of between about 1 percent by weight and about 10 percent by weight. For example, the formulation may have a metal salt content of between about 1 percent by weight and about 5 percent by weight. The formulation may have a metal salt content of between about 1 percent by weight and about 2 percent by weight.

[0053] The formulation may have an aerosol former content of greater than or equal to about 5 percent by weight. The formulation may have an aerosol former content of greater than or equal to about 10 percent by weight. The formulation may have an aerosol former content of greater than or equal to about 20 percent by weight. The formulation may have an aerosol former content of greater than or equal to about 30 percent by weight. The formulation may have an aerosol former content of greater than or equal to about 40 percent by weight.

[0054] The formulation may have an aerosol former content of greater than or equal to about 50 percent by weight.

[0055] The formulation may have an aerosol former content of greater than or equal to about 60 percent by weight. The formulation may have an aerosol former content of greater than or equal to about 70 percent by weight. The formulation may have an aerosol former content of greater than or equal to about 80 percent by weight. The formulation may have an aerosol former content of greater than or equal to about 90 percent by weight.

[0056] The formulation may have an aerosol former content of less than or equal to about 95 percent by weight.

[0057] The formulation may have an aerosol former content of between about 5 percent by weight and about 95 percent by weight. For example, the formulation may have an aerosol former content of between about 10 percent by weight and about 95 percent by weight. The formulation may have an aerosol former content of between about 20 percent by weight and about 95 percent by weight. The formulation may have an aerosol former content of between about 30 percent by weight and about 95 percent by weight. The formulation may have an aerosol former content of between about 40 percent by weight and about 95 percent by weight.

[0058] Preferably, the formulation has an aerosol former content of between about 50 percent by weight and about 95 percent by weight.

[0059] The formulation may have an aerosol former content of between about 60 percent by weight and about 95 percent by weight. For example, the formulation may have an aerosol former content of between about 70 percent by weight and about 95 percent by weight. The formulation may have an aerosol former content of between about 80 percent by weight and about 95 percent by weight. The formulation may have an aerosol former content of between about 90 percent by weight and about 95 percent by weight.

[0060] The formulation may comprise one or more aerosol formers selected from the group consisting of 1,3-butane-diol, glycerine, propylene glycol, triethylene glycol and sorbitol. The glycerine may comprise vegetable glycerine.

[0061] The one or more aerosol formers may comprise a combination of glycerine and propylene glycol. The one or more aerosol formers may comprise a combination of vegetable glycerine and propylene glycol.

[0062] In some preferred embodiments the one or more aerosol formers comprise a majority amount of glycerine. It has been found that glycerine based formulations may provide a harder solid material. It has also been found that including a minor amount of propylene glycol in glycerine based formulations may provide a less rigid or less brittle solid than glycerine based compositions containing no propylene glycol.

[0063] As discussed below, including propylene glycol in the formulation may improve vaporisation of the formulation, which can lead to the production of more aerosol for a given heating cycle.

[0064] By including propylene glycol in a glycerine based formulation that includes nicotine, there may also be an improvement in the nicotine content of the aerosol due to more efficient vaporisation of the nicotine because propylene glycol has a lower boiling point (188° C.) compared to glycerine (290° C.). However, if there is high amount of propylene glycol in the formulation then the nicotine content of the aerosol decreases because the propylene glycol can be

vaporised during a heating cycle. Therefore, it may be advantageous to have a limited amount of propylene glycol in the nicotine formulation.

[0065] The ratio of the weight percent glycerine content to the weight percent propylene glycol content of the formulation may be greater than or equal to about 1.

[0066] The ratio of the weight percent glycerine content to the weight percent propylene glycol content of the formulation may be greater than or equal to about 1.5. The ratio of the weight percent glycerine content to the weight percent propylene glycol content of the formulation may be greater than or equal to about 2. The ratio of the weight percent glycerine content to the weight percent propylene glycol content of the formulation may be greater than or equal to about 2.5. The ratio of the weight percent glycerine content to the weight percent propylene glycol content of the formulation may be greater than or equal to about 3.

[0067] It has been found that such compositions may provide a balance of hardness and rigidity or brittleness to provide an optimum seal in addition to the advantageous vaporization properties discussed herein.

[0068] The one or more aerosol formers may comprise one or more polyhydric alcohols. The one or more polyhydric alcohols may comprise one or more water-miscible polyhydric alcohols. As used herein, the term “water-miscible polyhydric alcohol” describes a polyhydric alcohol that is liquid at 20° C. and mixes with water in all proportions to form a homogenous solution.

[0069] The formulation may comprise water.

[0070] The formulation may have a water content of greater than or equal to about 0.5 percent by weight. The formulation may have a water content of greater than or equal to about 1 percent by weight. The formulation may have a water content of greater than or equal to about 5 percent by weight. The formulation may have a water content of greater than or equal to about 10 percent by weight. The formulation may have a water content of greater than or equal to about 15 percent by weight. The formulation may have a water content of greater than or equal to about 20 percent by weight.

[0071] The formulation may have a water content of less than or equal to about 30 percent by weight. The formulation may have a water content of less than or equal to about 25 percent by weight. The formulation may have a water content of less than or equal to about 20 percent by weight. The formulation may have a water content of less than or equal to about 15 percent by weight. The formulation may have a water content of less than or equal to about 10 percent by weight. The formulation may have a water content of less than or equal to about 8 percent by weight. The formulation may have a water content or less than or equal to about 5 percent by weight.

[0072] The formulation may have a water content of between about 0.5 percent by weight and about 30 percent by weight. The formulation may have a water content of between about 0.5 percent by weight and about 25 percent by weight. The formulation may have a water content of between about 0.5 percent by weight and about 20 percent by weight. The formulation may have a water content of between about 0.5 percent by weight and about 15 percent by weight. The formulation may have a water content of between about 0.5 percent by weight and about 10 percent by weight. The formulation may have a water content of between about 0.5 percent by weight and about 8 percent by

weight. The formulation may have a water content of between about 0.5 percent by weight and about 5 percent by weight.

[0073] The formulation may have a water content of between about 1 percent by weight and about 20 percent by weight. The formulation may have a water content of between about 5 percent by weight and about 20 percent by weight. The formulation may have a water content of between about 10 percent by weight and about 20 percent by weight. The formulation may have a water content of between about 15 percent by weight and about 20 percent by weight.

[0074] The formulation may comprise nicotine. The formulation may comprise liquid nicotine.

[0075] The nicotine may be a nicotine base. The nicotine may be a nicotine salt. The formulation may comprise natural nicotine. The formulation may comprise synthetic nicotine.

[0076] The nicotine may be provided as a tobacco extract which may include other tobacco components such as tobacco flavour components.

[0077] The formulation may have a nicotine content of greater than or equal to about 0.5 percent by weight. The formulation may have a nicotine content of greater than or equal to about 1 percent by weight. The formulation may have a nicotine content of greater than or equal to about 1.5 percent by weight. The formulation may have a nicotine content of greater than or equal to about 2 percent by weight. The formulation may have a nicotine content of greater than or equal to about 3 percent by weight. The formulation may have a nicotine content of greater than or equal to about 5 percent by weight.

[0078] The formulation may have a nicotine content of less than or equal to about 10 percent by weight. The formulation may have a nicotine content of less than or equal to about 8 percent by weight. The formulation may have a nicotine content of less than or equal to about 5 percent by weight. The formulation may have a nicotine content of less than or equal to about 3 percent by weight. The formulation may have a nicotine content of less than or equal to about 2 percent by weight.

[0079] The formulation may have a nicotine content of between about 0.5 percent by weight and about 10 percent by weight. For example, the formulation may have a nicotine content of between about 0.5 percent by weight and about 8 percent by weight. The formulation may have a nicotine content of between about 0.5 percent by weight and about 5 percent by weight. The formulation may have a nicotine content of between about 0.5 percent by weight and about 3 percent by weight. The formulation may have a nicotine content of between about 1 percent by weight and about 10 percent by weight. For example, the formulation may have a nicotine content of between about 1 percent by weight and about 8 percent by weight. The formulation may have a nicotine content of between about 1 percent by weight and about 5 percent by weight. The formulation may have a nicotine content of between about 1 percent by weight and about 3 percent by weight. The formulation may have a nicotine content of between about 1 percent by weight and about 2 percent by weight. The formulation may have a nicotine content of between about 2 percent by weight and about 5 percent by weight. The formulation may have a nicotine content of between about 2 percent by weight and about 3 percent by weight. The formulation may

have a nicotine content of between about 3 percent by weight and about 5 percent by weight.

[0080] Preferably, the formulation is a liquid at standard temperature and pressure.

[0081] The formulation may include one or more organic acids. In some embodiments the one or more organic acids may be water-soluble organic acids. As used herein with reference to the invention, the term “water-soluble organic acid” describes an organic acid having a water solubility at 20° C. of greater than or equal to about 100 mg/ml, preferably greater than or equal to about 500 mg/ml, more preferably greater than or equal to about 750 mg/ml most preferably greater than or equal to about 1000 mg/ml.

[0082] Unless stated otherwise, water solubility values recited herein are the water solubility measured based on the preliminary test of OECD (1995), Test No. 105: *Water Solubility*, OECD Guidelines for the Testing of Chemicals, Section 1, OECD Publishing, Paris, <https://doi.org/10.1787/9789264069589-en>. In a stepwise procedure, increasing volumes of distilled water are added at 20° C. to 0.1 g of the sample (solid substances must be pulverized) in a 10 ml glass-stoppered measuring cylinder. However, when the substance is an acid, the sample is added to the distilled water in the first step. After each addition of an amount of water, the mixture is shaken for 10 minutes and is visually checked for any undissolved parts of the sample. If, after addition of 10 ml of water, the sample or parts of it remain undissolved, the experiment is continued in a 100 ml measuring cylinder. The approximate solubility is given in Table 1 below under that volume of water in which complete dissolution of the sample occurs.

[0083] When the solubility is low, a long time may be required to dissolve a substance and at least 24 hours should be allowed. If, after 24 hours, the substance is still not dissolved, the measuring cylinder is placed for at 40° C. in an ultrasound bath for 15 minutes and another 24 hours allowed (up to a maximum of 96 hours). If the substance is still not dissolved, the solubility is considered to be below the limit value or not soluble.

TABLE 1

	ml of water in which 0.1 g of sample is soluble						
	0.1	0.5	1	2	10	100	>100
Approximate solubility (mg/ml)	>1000	1000 to 200	200 to 100	100 to 50	50 to 10	10 to 1	<1

[0084] The one or organic acids may be selected from the group consisting of: malonic acid, citric acid, 2-ethylbutyric acid, acetic acid, adipic acid, benzoic acid, butyric acid, cinnamic acid, cycloheptane-carboxylic acid, fumaric acid, glycolic acid, hexanoic acid, lactic acid, levulinic acid, malic acid, myristic acid, octanoic acid, oxalic acid, propanoic acid, pyruvic acid, succinic acid and undecanoic acid.

[0085] In some embodiments the one or more organic acids are selected from the group consisting of: malonic acid, citric acid, lactic acid, benzoic acid, levulinic acid, fumaric acid and acetic acid.

[0086] In some embodiments the one or more organic acids are selected from the group consisting of: malonic acid, citric acid, lactic acid, fumaric acid and acetic acid

[0087] Most preferably, the one or more organic acids consists of lactic acid.

[0088] The formulation may have an organic acid content of greater than or equal to about 0.1 percent by weight. The formulation may have an organic acid content of greater than or equal to about 0.5 percent by weight. The formulation may have an organic acid content of greater than or equal to about 1 percent by weight. The formulation may have an organic acid content of greater than or equal to about 2 percent by weight. The formulation may have an organic acid content of greater than or equal to about 3 percent by weight. The formulation may have an organic acid content of greater than or equal to about 4 percent by weight. The formulation may have an organic acid content of greater than or equal to about 5 percent by weight.

[0089] The formulation may have an organic acid content of less than or equal to about 6 percent by weight. The formulation may have an organic acid content of less than or equal to about 5 percent by weight. The formulation may have an organic acid content of less than or equal to about 4 percent by weight. The formulation may have an organic acid content of less than or equal to about 3 percent by weight. The formulation may have an organic acid content of less than or equal to about 2 percent by weight. The formulation may have an organic acid content of less than or equal to about 1 percent by weight. The formulation may have an organic acid content or less than or equal to about 0.5 percent by weight.

[0090] The formulation may have an organic acid content of between about 0.1 percent by weight and about 6 percent by weight. The formulation may have an organic acid content of between about 0.1 percent by weight and about 5 percent by weight. The formulation may have an organic acid content of between about 0.1 percent by weight and about 4 percent by weight. The formulation may have an organic acid content of between about 0.1 percent by weight and about 3 percent by weight. The formulation may have an organic acid content of between about 0.1 percent by weight and about 2 percent by weight. The formulation may have an organic acid content of between about 0.1 percent by weight and about 1 percent by weight. The formulation may have an organic acid content of between about 0.1 percent by weight and about 0.5 percent by weight.

[0091] The formulation may have an organic acid content of between about 0.5 percent by weight and about 6 percent by weight. The formulation may have an organic acid content of between about 1 percent by weight and about 6 percent by weight. The formulation may have an organic acid content of between about 2 percent by weight and about 6 percent by weight. The formulation may have an organic acid content of between about 3 percent by weight and about 6 percent by weight. The formulation may have an organic acid content of between about 4 percent by weight and about 6 percent by weight. The formulation may have an organic acid content of between about 5 percent by weight and about 6 percent by weight.

[0092] There is also provided a method of forming a formulation as disclosed herein.

[0093] The method may comprise a step of combining the components to form the formulation.

[0094] In some embodiments it may be preferable to combine the components in a specific order, particularly when a number of optional ingredients are included. Where one or more metal salts are present, the one or more aerosol

formers may first be combined and subsequently the one or more polymeric thickening agents are added. Further optional components may be added at any appropriate stage. Optionally, volatile components, such as nicotine, may be added as late as possible in the process to reduce losses during processing.

[0095] The aerosol-generating system may comprise an aerosol-generating article.

[0096] The aerosol-generating article may comprise an atomiser configured to generate an aerosol from the formulation.

[0097] The aerosol-generating article may be a cartridge.

[0098] A cartridge containing the formulation and an atomiser may be referred to as a “cartomiser”.

[0099] The atomiser may be a thermal atomiser.

[0100] As used herein, the term “thermal atomiser” describes an atomiser that is configured to heat the formulation to generate an aerosol.

[0101] The aerosol-generating article may comprise any suitable type of thermal atomiser. For example, the thermal atomizer may comprise a heater. The thermal atomiser may comprise an electric heater. In one example, the thermal atomiser may comprise an electric heater comprising a resistive heating element. In another example, the thermal atomiser may comprise an electric heater comprising an inductive heating element.

[0102] The heater may comprise a heating element. The heating element may be a grid element. The heating element may be a mesh element. The heating element may be a mesh layer. In such embodiments, the formulation may flow into the interstitial spaces forming the grid or mesh.

[0103] The aerosol-generating article may comprise a mixer. The mixer may be suitable for mixing at least two liquids. The mixer may be operable to stir the formulation in response to user input. In one example, the mixer may be mechanically operated. In another example, the mixer may be electrically operated. The mixer may be an agitator. The agitator may be a linear resonant actuator. The mixer may be a different type of device or mechanism that is suitable for mixing liquids, such as a magnetic stirrer.

[0104] Advantageously, including a mixer prevents particles of the polymeric thickening agent(s) from settling out of solution, which provides for a better seal.

[0105] The aerosol-generating system may comprise an aerosol-generating device.

[0106] The aerosol-generating device may comprise a reservoir for containing the formulation.

[0107] The aerosol-generating device may comprise a housing defining a device cavity configured to receive at least a portion of the aerosol-generating article.

[0108] The aerosol-generating device may comprise an atomiser configured to generate an aerosol from the formulation.

[0109] The atomiser may be a thermal atomiser.

[0110] As used herein, the term “thermal atomiser” describes an atomiser that is configured to heat the formulation to generate an aerosol.

[0111] The aerosol-generating device may comprise any suitable type of thermal atomiser. For example, the thermal atomizer may comprise a heater. The thermal atomiser may comprise an electric heater. In one example, the thermal atomiser may comprise an electric heater comprising a

resistive heating element. In another example, the thermal atomiser may comprise an electric heater comprising an inductive heating element.

[0112] The heater may comprise a heating element. The heating element may be a grid element. The heating element may be a grid layer. The heating element may be a mesh element. The heating element may be a mesh layer. In such embodiments, the formulation may flow into the interstitial spaces forming the grid or mesh.

[0113] The aerosol-generating device may comprise a mixer. The mixer may be suitable for mixing at least two liquids. The mixer may be operable to stir the formulation in response to user input. In one example, the mixer may be mechanically operated. In another example, the mixer may be electrically operated. The mixer may be an agitator. The agitator may be a linear resonant actuator. The mixer may be a different type of device or mechanism that is suitable for mixing liquids, such as a magnetic stirrer.

[0114] Advantageously, including a mixer prevents particles of the polymeric thickening agent(s) from settling out of solution, which provides for a better seal.

[0115] According to the invention there is further provided an aerosol-generating system comprising a formulation according to the invention and an atomiser configured to generate an aerosol from the formulation.

[0116] The atomiser may be a thermal atomiser.

[0117] The aerosol-generating system may comprise any suitable type of thermal atomiser.

[0118] The thermal atomiser may comprise an electric heater. For example, the thermal atomiser may comprise an electric heater comprising a heating element. The heating element may be a resistive heating element or an inductive heating element.

[0119] The heating element may be a grid or mesh element or layer. In such embodiments, the formulation may flow into the interstitial spaces forming the grid or mesh element.

[0120] The aerosol-generating system may comprise an aerosol-generating article according to the invention containing the formulation and an aerosol-generating device comprising a housing defining a device cavity configured to receive at least a portion of the aerosol-generating article.

[0121] The aerosol-generating system may comprise a consumable aerosol-generating article according to the invention containing the formulation and a reusable aerosol-generating device comprising a housing defining a device cavity configured to receive at least a portion of the aerosol-generating article.

[0122] The aerosol-generating device may comprise a battery and control electronics.

[0123] The aerosol-generating system may comprise: an aerosol-generating article according to the invention containing the formulation and the atomiser; and an aerosol-generating device comprising a housing defining a device cavity configured to receive at least a portion of the aerosol-generating article.

[0124] The aerosol-generating system may comprise: an aerosol-generating article according to the invention containing the formulation; and an aerosol-generating device comprising a housing defining a device cavity configured to receive at least a portion of the aerosol-generating article and the atomiser.

[0125] For the avoidance of doubt, features described above in relation to the formulation may also relate, where appropriate, to the aerosol-generating article, the aerosol-

generating device, and the aerosol-generating system. Similarly, features described above in relation to the aerosol-generating article may also relate, where appropriate, to the aerosol-generating device and to the aerosol-generating system, and vice versa.

[0126] Specific embodiments will now be described, by way of example only, with reference to the following examples and the accompanying drawings, in which:

[0127] FIG. 1 shows schematically a sectional side view of an aerosol-generating system comprising an aerosol-generating device and an aerosol-generating article comprising a formulation according to the invention;

[0128] FIG. 2 shows schematically a sectional view of the aerosol-generating system of FIG. 1, with the aerosol-generating article inserted into the aerosol-generating device;

[0129] FIG. 3 shows schematically a sectional view of an alternative aerosol-generating system comprising an aerosol-generating device and an aerosol-generating article comprising a formulation according to the invention;

[0130] FIG. 4 shows schematically a sectional view of an aerosol-generating article comprising a formulation according to the invention;

[0131] FIG. 5 shows schematically a sectional view of an aerosol-generating article comprising a formulation according to the invention

[0132] FIG. 6 is a graph showing average aerosolised collected mass in mg per puff for a range of different aerosol former compositions;

[0133] FIG. 7 is a graph showing average nicotine in mg per puff for a range of different aerosol former compositions; and

[0134] FIG. 8 is a graph showing average nicotine percent for a range of different aerosol former compositions.

[0135] Aerosol-generating systems for delivering to a user typically comprise an atomiser configured to generate an inhalable aerosol from a formulation. Some known aerosol-generating systems comprise a thermal atomiser such as an electric heater that is configured to heat and vaporise the formulation to generate an aerosol. Typical formulations for use in aerosol-generating systems are nicotine formulations, which may be liquid nicotine formulations comprising an aerosol former such as glycerine and/or propylene glycol.

[0136] An aerosol generating system can comprise an aerosol-generating device and an aerosol-generating article containing a formulation. Typical aerosol-generating systems may suffer from a problem of unwanted leakage of the formulation out of the aerosol-generating article. Leakage of a formulation may occur in a number of different situations, such as: when there is too much of the formulation in a reservoir of the aerosol-generating article; when the material forming one or more parts of the aerosol-generating article or system fails to retain the formulation as designed; due to a change in pressure, for example when at a high altitude during transport by an aeroplane; or at a high temperature, for example due to hot weather.

[0137] It would be desirable to provide a formulation that provides a reduced risk of leakage from an aerosol-generating article or system compared to typical formulations.

[0138] FIGS. 1 and 2 show an aerosol-generating system including an aerosol-generating device 10 and an aerosol-generating article 20. In this example, the aerosol-generating article 20 is cartridge.

[0139] The aerosol-generating device 10 is configured to receive the aerosol-generating article 20 in a cavity 18. The aerosol-generating article 20 includes a housing 24. The housing 24 defines a reservoir 22. The reservoir 22 has a reservoir opening that can be covered by a removable cover 26. An aerosol-forming substrate is disposed in the reservoir 22. The aerosol-forming substrate in the reservoir 22 may be a formulation according to the invention.

[0140] In the example shown in FIGS. 1 and 2, the aerosol-generating article 20 includes an atomiser configured to generate an aerosol from the formulation in the reservoir 22. The atomiser may be a thermal atomiser. In the example shown in FIGS. 1 and 2 the atomiser is an electric heater 30.

[0141] In the example of FIGS. 1 and 2, the aerosol-generating article 20 contains an aerosol-forming substrate and an atomiser and may therefore be referred to as a “cartomiser”.

[0142] The aerosol-generating article 20 is replaceable by a user when the aerosol-forming substrate provided in the reservoir 22 is depleted.

[0143] FIG. 1 shows the aerosol-generating article 20 just prior to insertion into the aerosol-generating device 10. The arrow 1 in FIG. 1 indicates the direction of insertion of the aerosol-generating article 20 in to the aerosol-generating device 10.

[0144] The aerosol-generating device 10 is portable and has a size comparable to a conventional cigar or cigarette. The aerosol-generating device 10 comprises a main body 11 and a mouthpiece portion 12. The main body 11 contains a battery 14, such as a lithium iron phosphate battery, control electronics 16 and a cavity 18.

[0145] The mouthpiece portion 12 is connected to the main body 11 by a hinged connection 21 and can move between an open position as shown in FIG. 1 and a closed position as shown in FIG. 2. The mouthpiece portion 12 is placed in the open position to allow for insertion and removal of an aerosol-generating article 20 and is placed in the closed position when the aerosol-generating system is to be used to generate aerosol.

[0146] The mouthpiece portion 12 comprises a plurality of air inlets 13 and an outlet 15. In use, a user sucks or puffs on the outlet 15 to draw air from the air inlets 13, through the mouthpiece portion to the outlet 15, and thereafter into the mouth or lungs of the user. Internal baffles 17 are provided to force the air flowing through the mouthpiece portion 12 past the aerosol-generating article 20.

[0147] The housing 24 includes a capillary material soaked in the aerosol-forming substrate. The capillary material in this example is positioned adjacent the electric heater 30.

[0148] The cavity 18 has a circular cross-section and is sized to receive a housing 24 of the aerosol-generating article 20. Electrical connectors 19 are provided at the sides of the cavity 18 to provide an electrical connection between the control electronics 16 and battery 14 and corresponding electrical contacts on the aerosol-generating article 20. This setup allows power to be supplied to the electric heater 30.

[0149] FIG. 2 shows the aerosol-generating article 20 inserted into the cavity 18 of the aerosol-generating device 10. In this position, the electrical connectors 19 rest against the corresponding electrical contacts on the aerosol-generating article 20. The cover 26 has been fully removed and the mouthpiece portion 12 has been moved to a closed position.

[0150] The mouthpiece portion 12 is retained in the closed position by a clasp mechanism (not illustrated). It will be apparent to a person of ordinary skill in the art that other suitable mechanisms for retaining the mouthpiece in a closed position may be used, such as a snap fitting or a magnetic closure.

[0151] The mouthpiece portion 12 in a closed position retains the aerosol-generating article 20 in electrical contact with the electrical connectors 19 so that a good electrical connection is maintained in use, whatever the orientation of the aerosol-generating system is.

[0152] In use, when the aerosol-generating device 10 is activated by a user, the electric heater 30 aerosolises at least a portion of the aerosol-forming substrate in the reservoir 22. As a user sucks or puffs on the outlet 15, air flows through the air inlets 13 and over the electric heater 30 and the capillary material. The air flowing over the electric heater 30 and the capillary material entrains the volatilized aerosol components from the vaporised aerosol-forming substrate. The air with entrained aerosol-forming substrate then flows out through the outlet 15 and to the user. This air flow regime is shown in FIG. 2.

[0153] FIG. 3 shows an alternative embodiment of an aerosol-generating system. The embodiment shown in FIG. 3 works in much the same way as the embodiment shown in FIGS. 1 and 2. However, in the embodiment of FIG. 3, the aerosol-generating article 20 is not removable from the aerosol-generating device 10. Instead, after the reservoir 22 has been depleted of aerosol-generating substrate, the reservoir 22 can be refilled by a user through a reservoir opening 40.

[0154] In FIG. 3 the reservoir opening 40 is shown in an open position in which it can be refilled with aerosol-generating substrate. The reservoir opening 40 can however be sealed with a closure such as a cap (not shown).

[0155] The embodiment shown in FIG. 3 otherwise works in a similar way to the embodiment shown in FIGS. 1 and 2.

[0156] FIGS. 4 and 5 are schematic sectional views of an alternative aerosol-generating article 200. FIG. 4 shows the aerosol-generating article 200 before it has been used by the user. The aerosol-generating article 200 includes a body 212 defining a reservoir 210 having a reservoir opening 215. Aerosol-forming substrate 211 is disposed in the reservoir 210. The aerosol-generating article 200 includes a heater 222 located across the reservoir opening 215. In this example, the heater 222 has a heating element in the form of a mesh layer 223. The aerosol-generating article 200 also includes a transfer element 224. The transfer element 224 is preferably formed from a porous material. In the example of FIG. 4, the transfer element 224 is formed from a layer of glass fibers. The transfer element 224 provides control of the flow of the aerosol-forming substrate 211 from the reservoir 210 to the mesh layer 213 of the heater 222. In this example, the aerosol-forming substrate 211 is a formulation according to the invention.

[0157] In use, the formulation flows from the reservoir 210 and into the porous transfer element 224. The formulation then flows to the mesh layer 223 of the heater 222, where it is thermally vaporised into an aerosol.

[0158] It may be advantageous to mix the aerosol-forming substrate 211 before or during heating of the aerosol-forming substrate 211 by the heater 222. Mixing the aerosol-forming substrate 211 ensures that the aerosol-forming sub-

strate **211** becomes or remains as a substantially homogeneous mixture. In the example shown in FIG. 4, the aerosol-generating article **200** includes a mixer that is operable to stir the aerosol-forming substrate **211**. The mixer may be mechanically operated or electrically operated. In this example, the mixer is an agitator **226**. The agitator **226** may be a linear resonant actuator. In other examples, the mixer may be a different type of device or mechanism that is suitable for mixing liquids, such as a magnetic stirrer. In another example, the aerosol-forming substrate **211** may be mechanically mixed by the user. In another example, the aerosol-forming substrate **211** may be mixed during the manufacturing process, for example by ultrasonic vibration.

EXAMPLES

[0159] Three formulations according to the invention (Examples A, B and C) are prepared having the compositions shown in Table 1. The formulations of Examples A, B and C are liquid at standard temperature and pressure.

TABLE 2

Example	A	B	C	
Glycerine (% by weight)	aerosol former	91	84	81
Sodium Stearate (% by weight)	metal salt	2	2	2
Polyvinyl Alcohol (% by weight)	Polymeric thickening agent	7	8	7
Water (% by weight)		0	6	10

[0160] The formulations A, B and C are prepared by mixing the components together in, for example, a vessel. The aerosol former, which in these examples is glycerine, is added into the vessel first. Next, the metal salt, which in these examples is sodium stearate, is added into the vessel. Water is then added into the vessel. Finally, the polymeric thickening agent, which in this case is polyvinyl alcohol, is added into the vessel. The components are then mixed together in the vessel.

[0161] The formulations of Examples A and B are then heated on a hot plate for a period of time. In this example, the formulations of Examples A and B are heated for six minutes. Samples of the formulations of Examples A and B are heated to different temperatures. In one example, a sample of the formulations of Examples A and B is heated to 200 degrees Celsius. In another example, the formulations of Examples A and B is heated to 120 degrees Celsius. In another example, the formulations of Examples A and B is heated to 90 degrees Celsius. The formulations of Examples A and B are then removed from the hot plate.

[0162] After cooling down, some of the six samples solidify. Examples A and B that are heated to 200 degrees Celsius both solidify. Examples A and B that are heated to 120 degrees Celsius also both solidify. The Example A that is heated to 90 degrees Celsius does not solidify and remains as a liquid. However, the Example B that is heated to 90 degrees does solidify.

[0163] An example of use of a formulation according to the invention as an aerosol-forming substrate will now be described with reference to the formulation of Example C when used as an aerosol-forming substrate **211** in the aerosol-generating article **200** shown in FIGS. 4 and 5.

[0164] Advantageously, as an initial step, the agitator **226** can be activated for a period of time in order to mix the aerosol-forming substrate. In another example, the aerosol-generating article **200** may be shaken by a user in order to

mix the aerosol-forming substrate **211**. The initial step of mixing ensures that the aerosol-forming substrate **211** is a substantially homogenous mixture prior to heating.

[0165] The aerosol-generating article **200** is then inserted into the aerosol-generating device **10** that is shown in FIG. 1.

[0166] The aerosol-generating device is then activated by a user. Activation of the aerosol-generating device involves activation of the heater **222** of the aerosol-generating article **200**. Activation of the heater **222** heats a portion of the aerosol-generating substrate **211** contained within the transfer element **224**. Heating of aerosol-forming substrate **211** contained within the transfer element **224** vaporises at least a portion of the aerosol-generating substrate **211** into an aerosol. In this example, the heater **222** is activated at a power of 0.8 Watts for a time of six minutes. In one example, the heater **222** may be activated at a different power level. In another example, the heater **222** may be activated for a different time period.

[0167] Activation of the heater **222** at a power of 0.8 Watts for six minutes increases the temperature of the mesh layer **223** to around 200 degrees Celsius.

[0168] When the mesh layer **223** of the heater **222** cools, the aerosol-forming substrate **211** that was heated but not evaporated solidifies into a solid layer **225**. The solid layer **225** may be held within the transfer element **224**. In this example, the solid layer **225** that is formed completely covers the reservoir opening **215**.

[0169] FIG. 5 shows the aerosol-generating article **200** after a first use by a user. That is, FIG. 5 shows the aerosol-generating article **200** after a first heating cycle of six minutes has occurred.

[0170] As can be seen from FIG. 5, after the first use of the aerosol-generating article **200**, a solid layer **225** has been formed partially within the transfer element **224**. The solid layer **225** is also in contact with the mesh layer **223** of the heater **222**. In the example shown in FIG. 5, the solid layer **225** internally seals the reservoir opening **215**. Advantageously, sealing the reservoir opening **215** may prevent the formulation (that is, the aerosol-forming substrate) from escaping from the reservoir **210**.

[0171] The aerosol-generating article **200** may be used several times before the aerosol-generating substrate **211** contained within the reservoir **210** is fully consumed. Thus, the aerosol-generating article **200** may experience multiple heating cycles.

[0172] Before a second heating cycle, the solid layer **225** remains in position blocking the porous mesh layer **223** (as is shown in FIG. 5) and preventing escape of the formulation out of the reservoir opening **215**. When the aerosol-generating article **200** is used for a second time, the heater **222** is activated for a second heating cycle. Activating the heater **222** for a second heating cycle **222** heats the mesh layer **223**. Heating the mesh layer **223** increases the temperature of the solid layer **225** that is formed on the mesh layer **223** until the solid layer **225** melts into a liquid. At this point, in some examples, the aerosol-forming substrate may be fully liquid. As the temperature of the aerosol-forming substrate **211** increases, a portion of the aerosol-forming substrate **211** is vaporised by the heater **222**.

[0173] After the second heating cycle has finished, as the mesh layer **223** of the heater **222** cools, the aerosol-forming substrate **211** that was heated but not evaporated solidifies within the transfer element **224** into another solid layer **225**.

In this example, the solid layer **225** again covers the mesh layer **223** and therefore again seals the reservoir opening **215**, thereby preventing aerosol-forming substrate **211** from leaking out of the reservoir **210**.

[0174] In an alternative example, the first heating cycle is activated during manufacturing. For example, the first heating cycle may be activated after the reservoir **210** has been filled with the aerosol-forming substrate **211**.

[0175] In one example, a further step is carried out. This further step is optional and not necessary to provide the advantages and effects of the invention. After a heating cycle has been activated and the solid layer **225** begins to form as the aerosol-forming substrate **211** cools, the aerosol-generating article **200** is rotated into a particular orientation that promotes formation of the solid layer **225** in a position that blocks the mesh layer **223**, thereby sealing the reservoir opening **215** closed. For example, the aerosol-generating article **200** may be stored upside down after the first heating cycle.

[0176] Advantageously, the solid layer **225** formed after the formulation cools down provides a barrier that seals the reservoir opening **215** closed. Sealing the reservoir **215** prevents fluid from escaping out of the reservoir **215**. Accordingly, the solid layer **225** prevents the formulation from leaking out of the reservoir **215** between uses of the aerosol-generating device **600**. A reservoir seal may be advantageous in certain circumstances that typically result in leakage of formulation out of the reservoir **215**, such as due to changes in pressure (for example when a user is climbing a mountain or travelling in an aeroplane) and at high temperatures (for example due to strong summer heat).

[0177] FIG. 6 shows the average aerosolised collected mass in mg per puff for a range of different aerosol former compositions when the weight percent of propylene glycol (PG) is varied relative to the weight percent of vegetable glycerine (VG). For example, the data for “25% PGvsVG” is for a formulation comprising an aerosol former composition that contains 25 percent by weight propylene glycol and 75 percent by weight vegetable glycerine.

[0178] FIG. 7 is a graph showing average nicotine in mg per puff for a range of different aerosol former compositions when the weight percent of propylene glycol (PG) is varied relative to the weight percent of vegetable glycerine (VG). For example, the data for “25% PGvsVG” is for a formulation comprising an aerosol former composition that contains 25 percent by weight propylene glycol and 75 percent by weight vegetable glycerine.

[0179] FIG. 8 is a graph showing average nicotine percent for a range of different aerosol former compositions when the weight percent of propylene glycol (PG) is varied relative to the weight percent of vegetable glycerine (VG). For example, the data for “25% PGvsVG” is for a formulation comprising an aerosol former composition that contains 25 percent by weight propylene glycol and 75 percent by weight vegetable glycerine.

[0180] The data in the graphs shows that, as discussed above, by including propylene glycol as an aerosol former in a formulation that includes nicotine, there is an improvement in the nicotine content of the aerosol. For example, the highest weight percent of nicotine is when there is 5 weight percent of propylene glycol in the aerosol former. This improvement may be due to more efficient vaporisation of the nicotine because propylene glycol has a lower boiling point (188° C.) compared to glycerine (290° C.).

[0181] However, if there is high amount of propylene glycol in the formulation (for example 25 percent by weight propylene glycol) then the nicotine content of the aerosol decreases because the propylene glycol can be vaporised during a heating cycle. Therefore, it is advantageous to have a limited amount of propylene glycol in the nicotine formulation.

[0182] The exemplary embodiments described above are not intended to limit the scope of the claims. Other embodiments consistent with the exemplary embodiments described above will be apparent to those skilled in the art. Features described in relation to one embodiment may also be applicable to other embodiments.

1.-14. (canceled)

15. A formulation for an aerosol-generating system, the formulation comprising:

one or more aerosol formers;

one or more metal salts; and

one or more polymeric thickening agents,

wherein the formulation has a polymeric thickening agent content of greater than or equal to about 0.5 percent by weight, and

wherein the one or more metal salts include one or more metal stearates.

16. The formulation according to claim 15, wherein the formulation has a polymeric thickening agent content of between about 5 percent by weight and about 20 percent by weight.

17. The formulation according to claim 15, wherein the one or more polymeric thickening agents are selected from the group consisting of: polyvinyl alcohol, polyethylene glycol, polypropylene glycol, and starch.

18. The formulation according to claim 15, wherein the one or more metal salts are selected from the group consisting of: metal alginates, metal benzoates, metal cinnamates, metal cycloheptanecarboxylates, metal levulinates, metal propanoates, metal stearates, and metal undecanoates.

19. The formulation according to claim 18, wherein the one or more metal salts are selected from the group consisting of metal cinnamates, metal cycloheptanecarboxylates, metal stearates, and metal undecanoates.

20. The formulation according to claim 15, wherein the formulation has a metal stearate content of greater than or equal to about 0.5 percent.

21. The formulation according to claim 15, wherein the one or more metal stearates comprise sodium stearate.

22. The formulation according to claim 15, wherein the one or more aerosol formers comprise glycerine.

23. The formulation according to claim 22, wherein the one or more aerosol formers comprise glycerine and propylene glycol.

24. The formulation according to claim 23, wherein a ratio of the weight percent glycerine content to the weight percent propylene glycol content of the formulation is greater than or equal to about 1.5.

25. The formulation according to claim 15, wherein the formulation has an aerosol former content of greater than or equal to about 50 percent by weight.

26. The formulation according to claim 15, further comprising water.

27. The formulation according to claim 26, wherein the formulation has a water content of less than or equal to about 30 percent by weight.

28. An aerosol-generating article for an aerosol-generating system, the aerosol-generating article containing a formulation according to claim **15**.

29. An aerosol-generating system, comprising:
a formulation according to claim **15**; and
an atomiser configured to generate an aerosol from the formulation.

* * * * *