

Nov. 11, 1947.

C. W. GINTER

2,430,608

SERVICE APPARATUS FOR AUTOMOBILES

Filed April 26, 1944

2 Sheets-Sheet 1

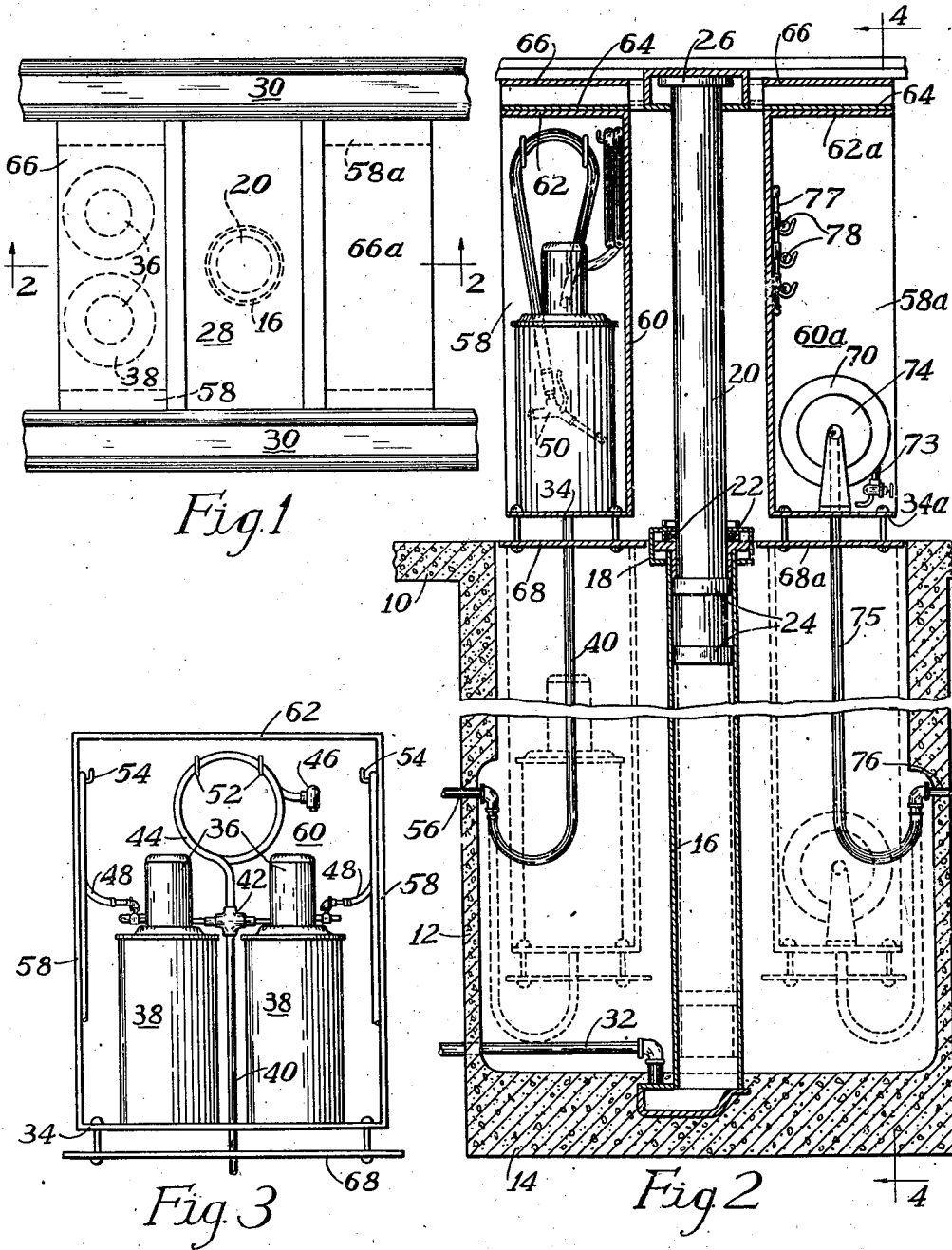

INVENTOR.
Charles W. Ginter
BY
Bair & Freeman
Atty's

Nov. 11, 1947.

C. W. GINTER

2,430,608

SERVICE APPARATUS FOR AUTOMOBILES

Filed April 26, 1944

2 Sheets-Sheet 2

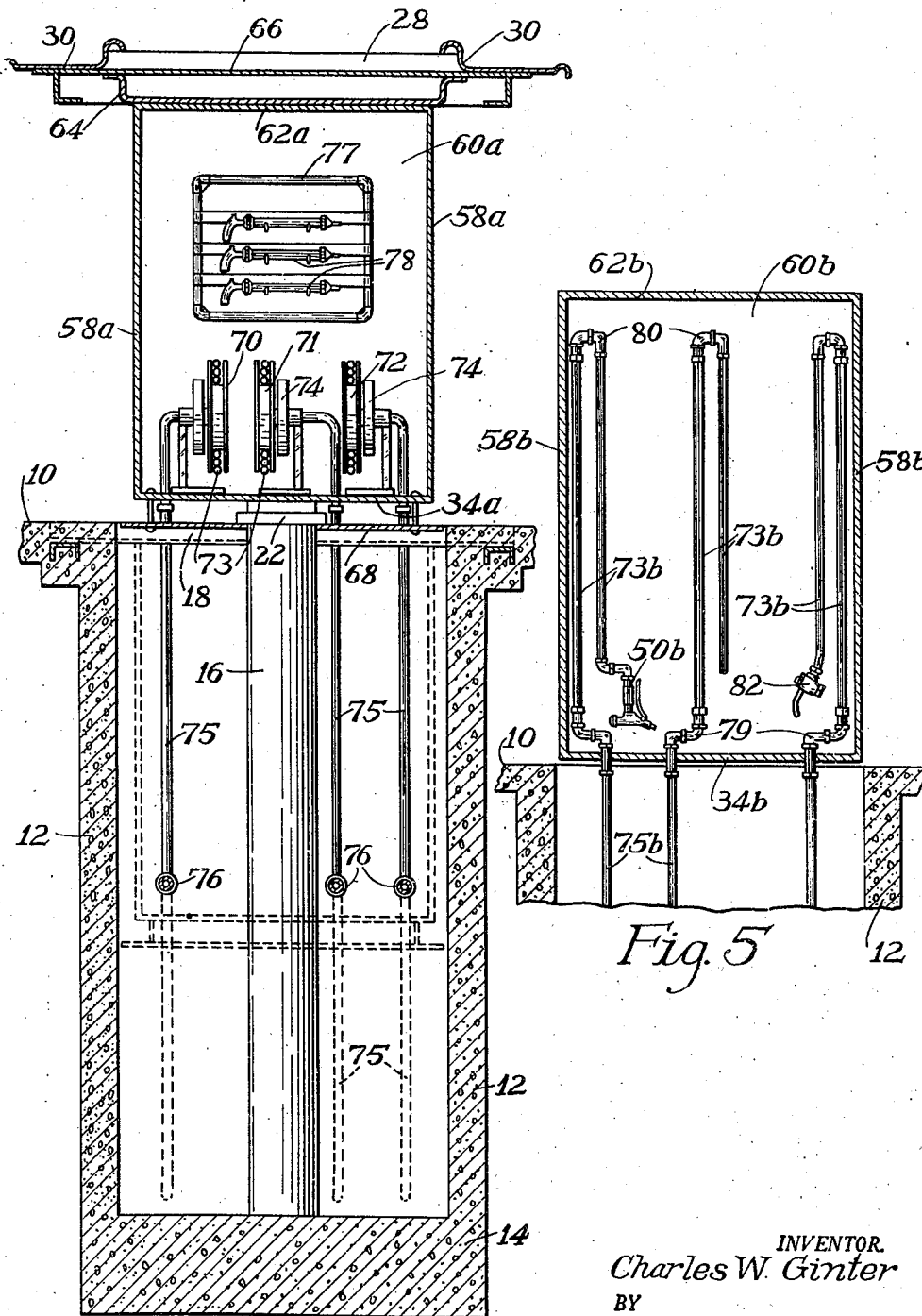

Fig. 4

Fig. 5

INVENTOR.
Charles W. Ginter
BY
Bair & Freeman
Attys

UNITED STATES PATENT OFFICE

2,430,608

SERVICE APPARATUS FOR AUTOMOBILES

Charles W. Ginter, Bryan, Ohio, assignor to The
Aro Equipment Corporation, Bryan, Ohio, a
corporation of Ohio

Application April 26, 1944, Serial No. 532,743

6 Claims. (Cl. 184—1.5)

1

My present invention relates to a service apparatus for automobiles and the like wherein the apparatus is connected with and supported by an automobile lift.

One object of the invention is to provide apparatus for servicing automobiles with grease, oil, compressed air, water and the like which is mounted on an automobile lift so that it is beneath the automobile in a position for convenient use in connection with an automobile on the lift when the lift is in raised position, the service apparatus being concealed in a pit beneath the lift when the lift is lowered.

Another object is to provide permanent connections to the service apparatus for supplying various service fluids thereto such as lubricant, air and water under pressure and which is not interfered with when the lift is lowered with the service apparatus positioned in the pit.

Still another object is to provide platforms or cabinets suspended from the rails of a lift to support, and partially house, if desired, service apparatus in a neat arrangement when the lift is raised and for convenience in extracting supply hoses from the platforms or cabinets when it is desirable to use any of them in connection with servicing the automobile.

With these and other objects in view my invention with respect to its features which I believe to be novel and patentable will be pointed out in the claims appended hereto. For a better detailed understanding of the invention, and further objects relating to details of economy of my invention, reference is made to the following description and to the accompanying drawings wherein such further objects will definitely appear and, in which:

Figure 1 is a plan view of a portion of an automobile lift with my service apparatus mounted thereon.

Figure 2 is a vertical sectional view on the line 2—2 of Figure 1 showing the lift in raised position and by dotted lines the lowered position of the service apparatus.

Figure 3 is a front elevation of the left-hand service cabinet in Figure 2.

Figure 4 is a vertical sectional view on the line 4—4 of Figure 2 showing the right-hand cabinet and

Figure 5 is a sectional view through a modified form of cabinet showing a different arrangement of service hoses therein.

On the accompanying drawings I have used the reference numeral 10 to indicate a floor of a garage or service station and preferably formed

2

of concrete. The floor 10 has a pit therein provided with side walls 12 and a bottom wall 14. The bottom wall 14 has embedded therein the lower end of a stationary cylinder 16 the upper end of which is supported by a cross member 18.

Slidable within the cylinder 16 is a lifting plunger 20 suitably packed as at 22 to prevent leakage. The plunger 20 is shown as provided with a pair of annular enlargements 24 on its lower end to guide it within the cylinder with the upper one serving as a stop. The plunger 20 has a head 26 on which a cross member 28 is mounted and on the ends of this cross member a pair of drive-on rails 30 are secured. Instead of drive-on rails of course there may be the usual free-wheel rails.

The lift and its details form no part of my present invention and are well known in garages and service stations. I have merely applied my service apparatus to the foregoing described lift and my invention contemplates a pit 12—14 of sufficient size to receive the service apparatus as will hereinafter appear, whereas ordinarily the pit 12—14 may be only slightly larger than the cylinder 16 or the cylinder may be directly embedded in a column of cement. Compressed air or oil under pressure may be supplied to the cylinder 16 as through a pipe 32 for effecting elevation of the plunger 20 and the usual valves or other control devices may be provided therefor.

Describing my service apparatus; one or more platforms such as 34 and 34a may be provided for supporting service apparatus such as grease or oil pumps 36 operated by compressed air, electricity or the like and mounted on oil or grease drums 38. By way of example I show a compressed air hose 40 supplying air to the pumps 36 from a cross 42 and a second hose 44 may extend on upwardly from the cross and terminate in an air chuck 46 for supplying compressed air to the tires at one end of the automobile. The grease or oil under high pressure from the pumps 36 is fed to hoses 48 which terminate in suitable control nozzles 50. The hose 44 and the hoses 48 may be supported as on hooks 52 and 54 respectively when not in use whereby they may be conveniently removed from the hooks so that the chuck 46 and nozzles 50 can be applied wherever it is desired when servicing an automobile on the lift.

The air supply hose 40 depends into the pit 12—14 as shown in Figure 2 and after looping downwardly is connected with an air supply pipe 56. Accordingly the air is suitably supplied both when the lift is raised and when it is low-

3

ered. As shown by dotted lines in this figure, the loop lengthens out as the lift is lowered and accommodates the platform 34 within the pit 12—14 without interference.

The platform 34 may be supported from the rails 30 by means of a pair of side walls 58 and a back wall 59 that form a partial enclosure or cabinet for the pumps 36 and the drums 38. Such cabinet may have a top 62 connected to a steel plate 64 as shown in Figure 4 and this plate in turn may be connected to a second plate 66 that is welded or otherwise suitably secured to the rails 30. Below the platform 34 a closure plate 68 may be provided for the pit 12—14 when the lift is in the raised position. This effectively prevents tools or other objects from dropping into the pit, the closure plate 68 being of such size as to substantially fit the width of the pit and the distance between the end of the pit and the cross member 18.

The other platform 34a has a similar cabinet arrangement and parts bearing similar numerals from 58 to 68 with the addition of small *a*. In the cabinet 58a—60a a different arrangement of service apparatus is provided in the form of three hose reels 70, 71 and 72. These may have hoses 73 for air, water, grease, oil or the like which may be suitably spring returned by coil springs mounted in housing 74 in an obvious manner. Supply hoses 75 extend from stationary pipes 76 in the pit 12—14 and supply the various service fluids to the hoses in the reels. Space permitting, the cabinet 58a—60a may have a supporting rack 77 for grease or oil guns 78 or the like, and the service apparatus in one cabinet may provide the necessary service fluids for one end of the automobile while those in the other end of the cabinet may provide the necessary fluids for the other end thereof.

In Figure 5 I have shown a modification in which the parts bear similar reference numerals with the addition of *b*. Instead of the hoses 73 of Figure 4, rigid pipes 73b are provided having swivel joints indicated at 79 and 80. The pipes may terminate in supply nozzles 50b, meters 82 or the like, whatever is suitable for the particular servicing job at hand.

From the foregoing description it will be obvious that I have provided service apparatus which is out of the way and out of sight when the lift is lowered so that the job of keeping the service apparatus clean from dust settling on it is considerably cut down and unsightly miscellaneous pieces of service apparatus, grease guns and the like, together with their fittings are all safely stored out of the way when not in use. At the same time the service apparatus is brought into position automatically for use when an automobile is raised on the lift, and is then in a position that minimizes the length of hose necessary and the steps of the operator necessary to change from one operation to another during lubrication or other servicing operations on the automobile. The arrangement is such as to provide incentive to keep the apparatus in its proper place and thereby insure against loss of various parts thereof when the apparatus is not in use.

Attention necessary for moving the service apparatus from a stored position to a position of use is eliminated by permanently attaching it to the lift. The apparatus is thereby automatically brought into position for use each time that the lift is raised. The entire design is conducive to the provision of a neat service station and one

4

wherein the necessary time for servicing operations are reduced to a minimum.

Various changes, such as the modification in Figure 5 to take the place of either cabinet shown in Figure 2, are possible without departing from the real spirit and purpose of my invention and it is my intention to cover by my claims any modified forms of structure or use of mechanical equivalents which may be reasonably included within their scope without sacrificing any of the advantages thereof.

I claim as my invention:

1. Service apparatus for use with a lift having a lifting surface adapted to be positioned above ground level and comprising a platform mounted on and movable with said lift below said lifting surface, servicing apparatus mounted on said platform, a pit below the lift adapted to receive and enclose a servicing apparatus when the lift is lowered, said platform, with the servicing apparatus thereon being at ground level when the lift is raised to its normal position, supply sources in said pit and flexible connections between the servicing apparatus and the supply sources in the pit, which flexible connections are contained in the pit without interference with the servicing apparatus when it is lowered into the pit.

2. Service apparatus for use with a lift having a lifting surface adapted to be positioned above ground level and comprising a platform mounted on and movable with said lift below said lifting surface, servicing apparatus mounted on said platform, a pit below the lift adapted to receive and enclose a servicing apparatus when the lift is lowered, said platform, with the servicing apparatus thereon being at ground level when the lift is raised to its normal position, supply sources in said pit and flexible connections between the servicing apparatus and the supply sources in the pit, which flexible connections are contained in the pit without interference with the servicing apparatus when it is lowered into the pit, supply pipes terminating in said pit and flexible hose connections supplying service fluids to said servicing apparatus and connected within said pit to the supply pipes, so that the servicing apparatus may be lowered into said pit without interference of the apparatus or supply pipes with each other.

3. Service apparatus for use with a lift having a lifting surface adapted to be positioned above ground level and comprising a cabinet mounted on and movable with said lift below said lifting surface, said cabinet having a lower supporting surface, servicing apparatus contained within said cabinet on said supporting surface, a pit below the lift adapted to receive and enclose said cabinet and servicing apparatus when the lift is lowered, said lower supporting surface of the cabinet being positioned substantially at ground level when the lift is raised to its normal position, supply sources in said pit and flexible connections between the servicing apparatus and the supply sources in the pit, which flexible connections are contained in the pit without interference with the servicing apparatus when it is lowered into the pit.

4. Service apparatus for use with a lift having a lifting surface adapted to be positioned above ground level and comprising a cabinet mounted on and movable with said lift below said lifting surface, said cabinet having a lower supporting surface, servicing apparatus contained within said cabinet on said supporting surface, a pit below the lift adapted to receive and enclose said

5

cabinet and servicing apparatus when the lift is lowered, said lower supporting surface of the cabinet being positioned substantially at ground level when the lift is raised to its normal position, supply sources in said pit, flexible connections between the servicing apparatus and the supply sources in the pit, which flexible connections are contained in the pit without interference with the servicing apparatus when it is lowered into the pit and hose connections associated with said service apparatus and having discharge fittings on their outer ends.

5. Service apparatus for use with a lift having a lifting surface adapted to be positioned above ground level and comprising a cabinet mounted on and movable with said lift below said lifting surface, said cabinet having a lower supporting surface, servicing apparatus contained within said cabinet on said supporting surface, a pit below the lift adapted to receive and enclose said cabinet and servicing apparatus when the lift is lowered, said lower supporting surface of the cabinet being positioned substantially at ground level when the lift is raised to its normal position, supply sources in said pit, flexible connections between the servicing apparatus and the supply sources in the pit, which flexible connections are contained in the pit without interference with the servicing apparatus when it is lowered into the pit and hose connections associated with said service apparatus and having discharge fittings on their outer ends, said hose connections being extendable from said service apparatus to different parts of the lift for servicing a vehicle thereon.

6

6. Service apparatus for use with a lift having a lifting surface adapted to be positioned above ground level and comprising a cabinet mounted on and movable with said lift below said lifting surface, said cabinet having a lower supporting surface, servicing apparatus contained within said cabinet on said supporting surface, a pit below the lift adapted to receive and enclose said cabinet and servicing apparatus when the lift is lowered, said lower supporting surface of the cabinet being positioned substantially at ground level when the lift is raised to its normal position. supply sources in said pit, flexible connections between the servicing apparatus and the supply sources in the pit, which flexible connections are contained in the pit without interference with the servicing apparatus when it is lowered into the pit and hose connections associated with said service apparatus and having discharge fittings on their outer ends, the bottom of said cabinet closing the top of said pit when the lift is in its normal raised position.

CHARLES W. GINTER.

REFERENCES CITED

The following references are of record in the file of this patent:

UNITED STATES PATENTS

30	Number	Name	Date
	1,888,446	Haines _____	June 27, 1916
	2,225,622	Clapp _____	Dec. 24, 1940
	1,867,602	Stukenborg _____	July 19, 1932
35	1,987,083	Smith _____	Jan. 8, 1935