

- [54] ROOM STATUS SYSTEM FOR HOTELS
- [76] Inventor: Cleveland B. Crudgington, Jr., P.O. Box 836, San Rafael, Calif. 94901
- [22] Filed: Nov. 5, 1970
- [21] Appl. No.: 87,248
- [52] U.S. Cl. 340/286 R, 340/332 R
- [51] Int. Cl. G08b 5/00
- [58] Field of Search..... 340/280, 286, 332

3,469,251 9/1969 Beilfuss..... 340/280 X

Primary Examiner—Harold I. Pitts

[57] ABSTRACT

A closed signaling system which enables the status of a plurality of rooms in a hotel, motel or motor inn, to be quickly ascertained as to occupancy or service condition from a central station. The system comprises a clerk's console at the front desk which is electrically connected to a panel at the cashier's station and to either a housekeeper's panel or to separate room or floor panels. At the clerk's station, cashier's station, floor panels, or housekeeper's station, rooms are represented on the panels by button-lights incorporating a switch. Each button-light utilizes an ionizing gas glow lamp, such as a neon lamp, that is connected to its own voltage divider circuit, controlling the on-off condition of the bulb. These circuits are interconnected at the various stations in the system so that the light for one room at one station can be controlled by actuation of a switch for the same room at another station. Variations in room panels provide for signaling in different ways to indicate either inspection or occupancy status as well as a maid locator function.

[56] References Cited
UNITED STATES PATENTS

1,482,911	2/1924	Catlin.....	340/286 R
2,964,680	12/1960	Irvin.....	340/332 X
3,141,966	7/1964	Milnes.....	340/332 UX
3,155,957	11/1964	Parissi.....	340/332 X
3,251,050	5/1966	Given.....	340/286 R
3,461,444	8/1969	Eisele.....	340/332 R
3,440,641	4/1969	Poulos.....	340/311 R
3,525,989	8/1970	Fagan.....	340/286 R
2,980,890	4/1961	Staten.....	340/286 X
3,214,747	10/1965	Lurie.....	340/286
3,215,998	11/1965	Cloyd.....	340/286
3,228,020	1/1966	Gassenheimer.....	340/286
3,230,520	1/1966	Lurie.....	340/286
3,254,335	5/1966	Staten.....	340/286

6 Claims, 11 Drawing Figures

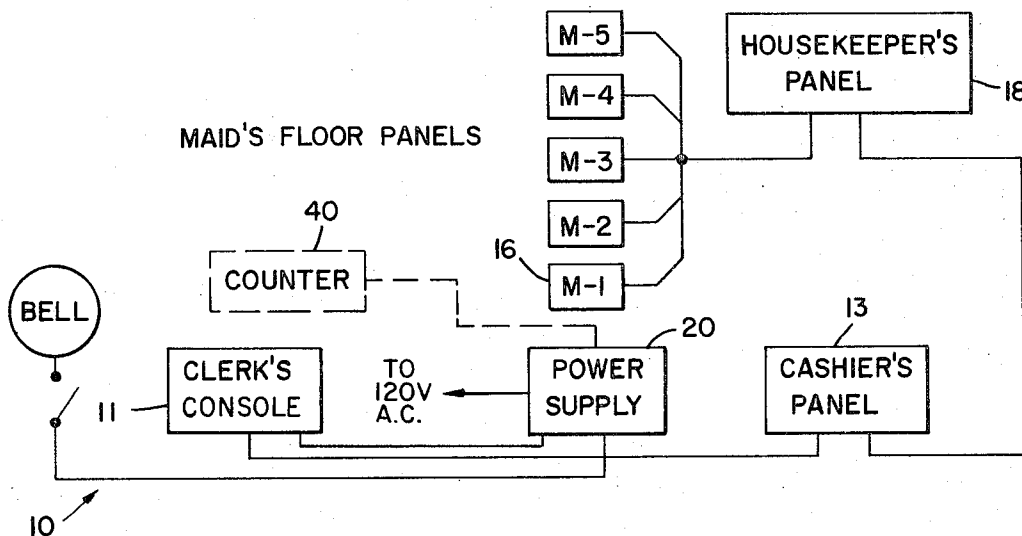

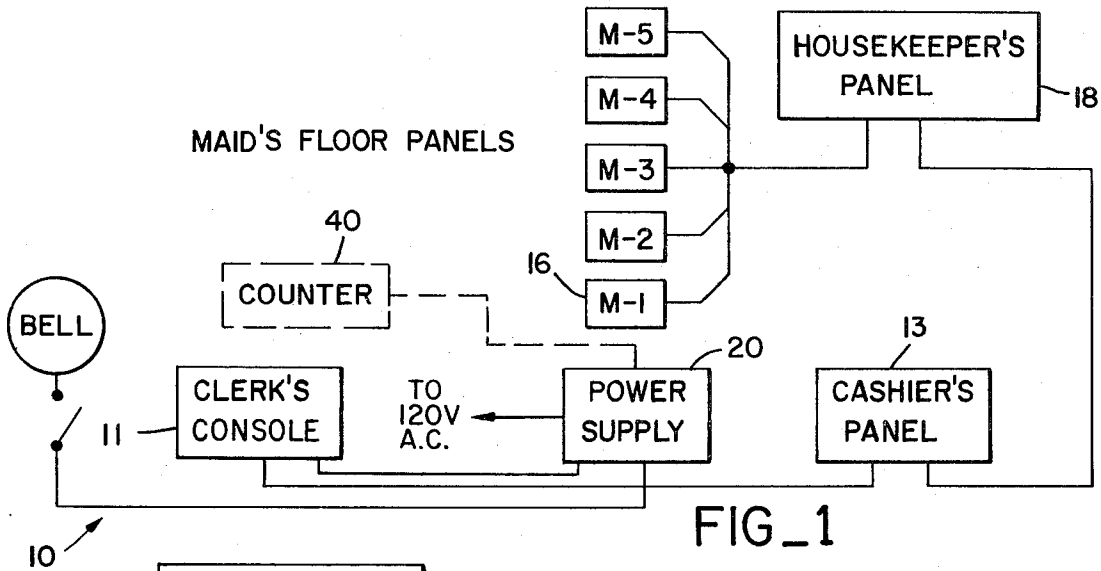

FIG_1

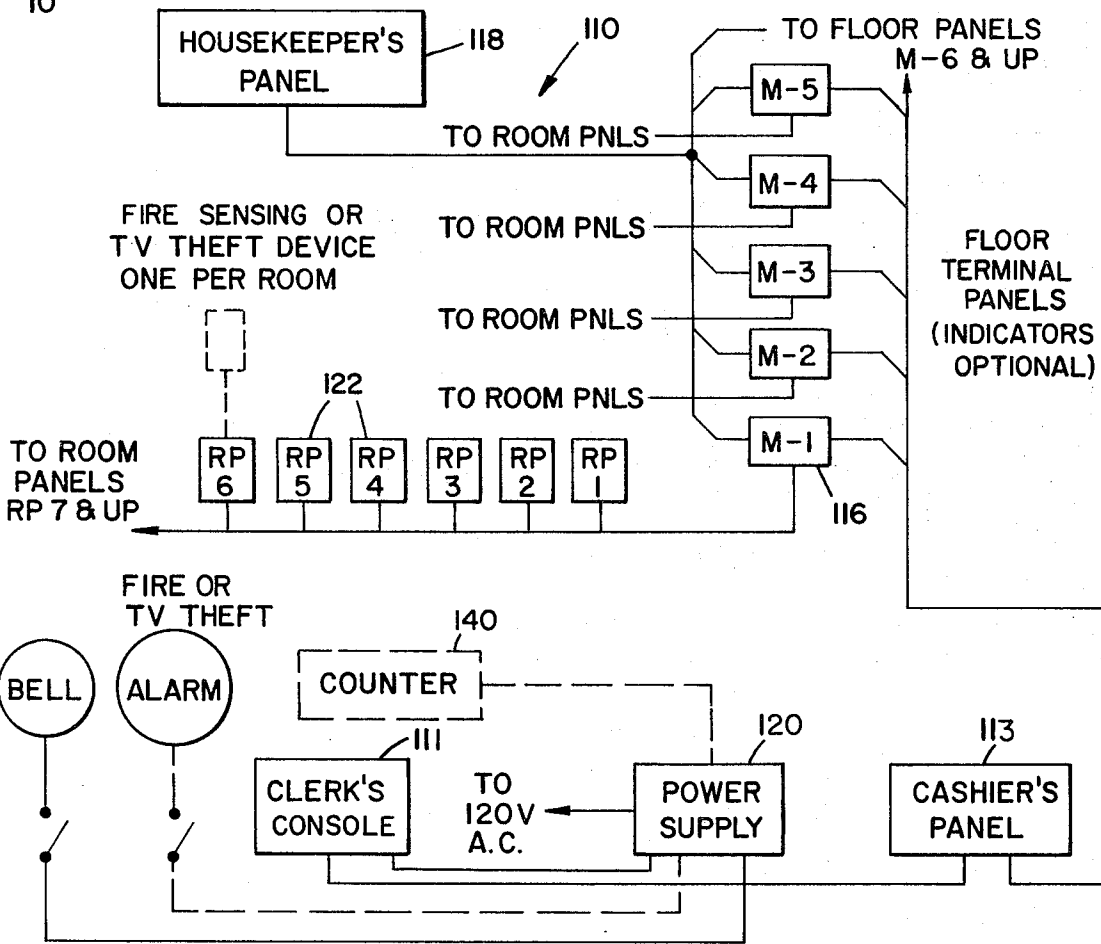

FIG_3

INVENTOR.
CLEVELAND B. CRUDGINGTON, JR

BY

Owen, Wickerham & Siskin
ATTORNEYS

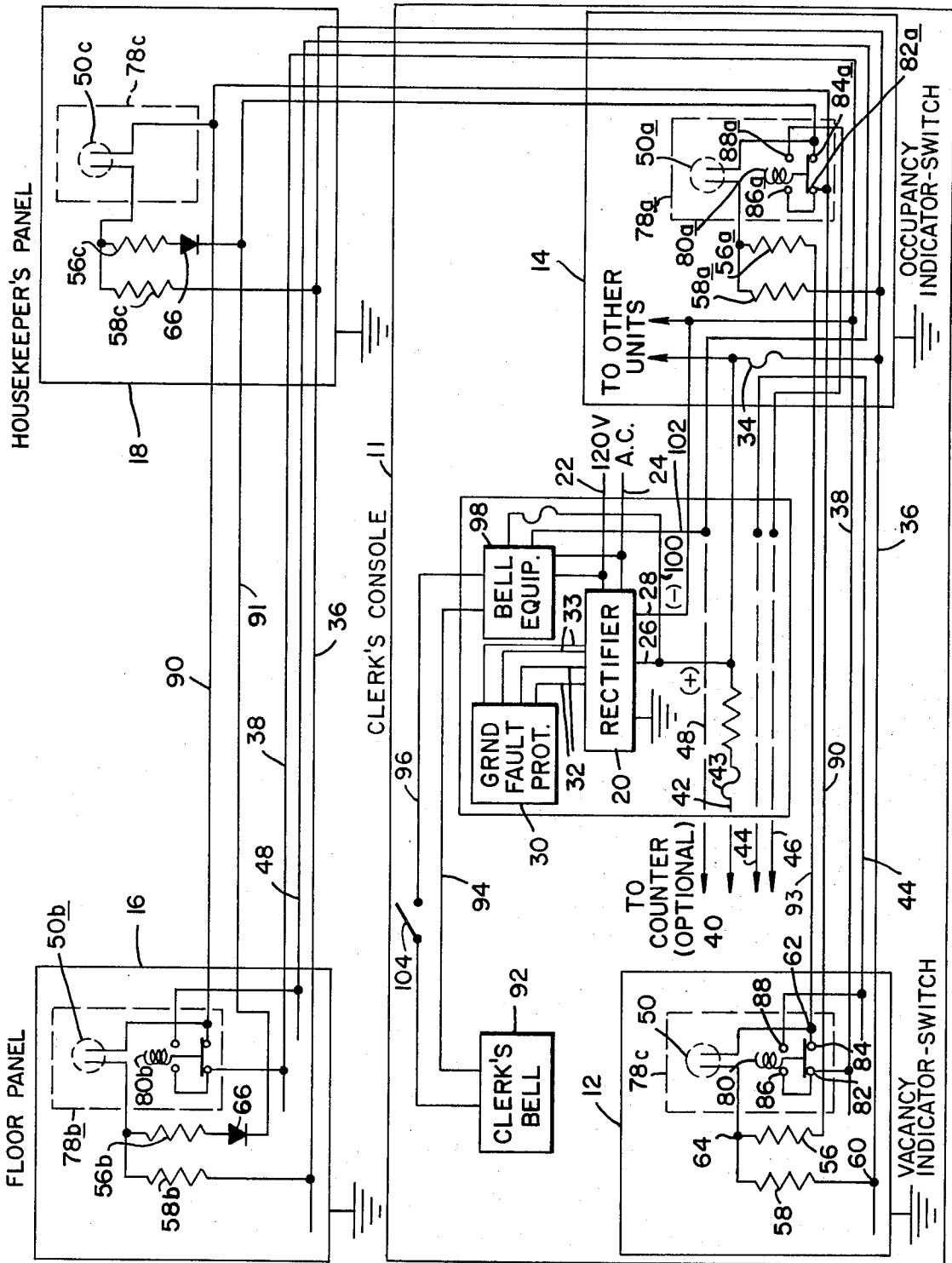

FIG. 2
10 →

INVENTOR
 CLEVELAND B. CRUDGINGTON, JR.
 BY
Owen, Wickert & Suckow
 ATTORNEYS

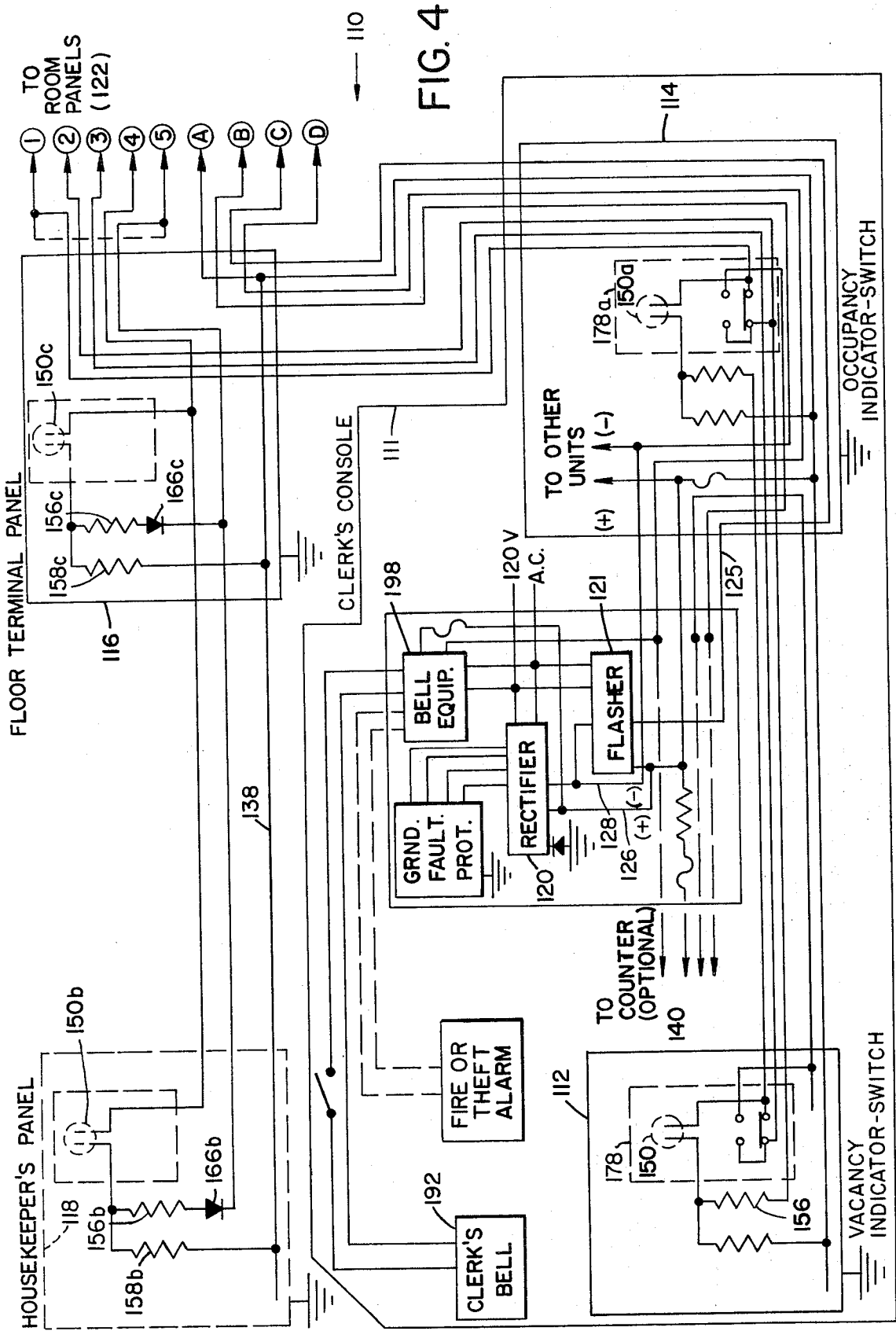
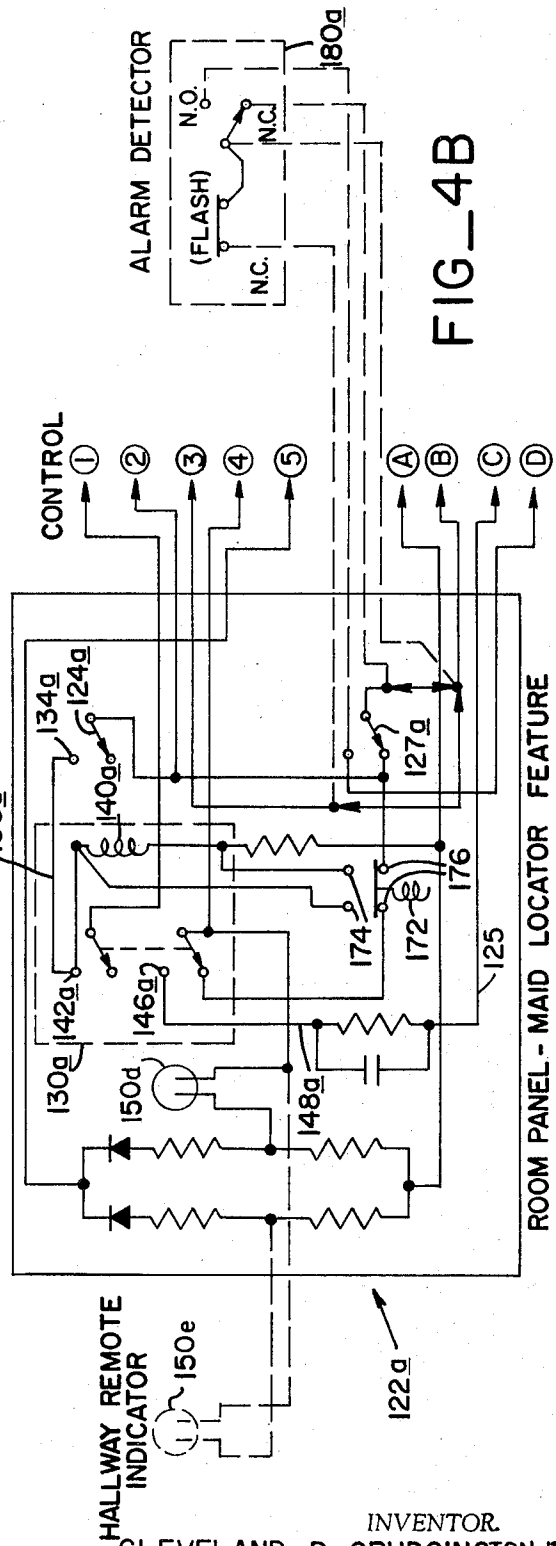
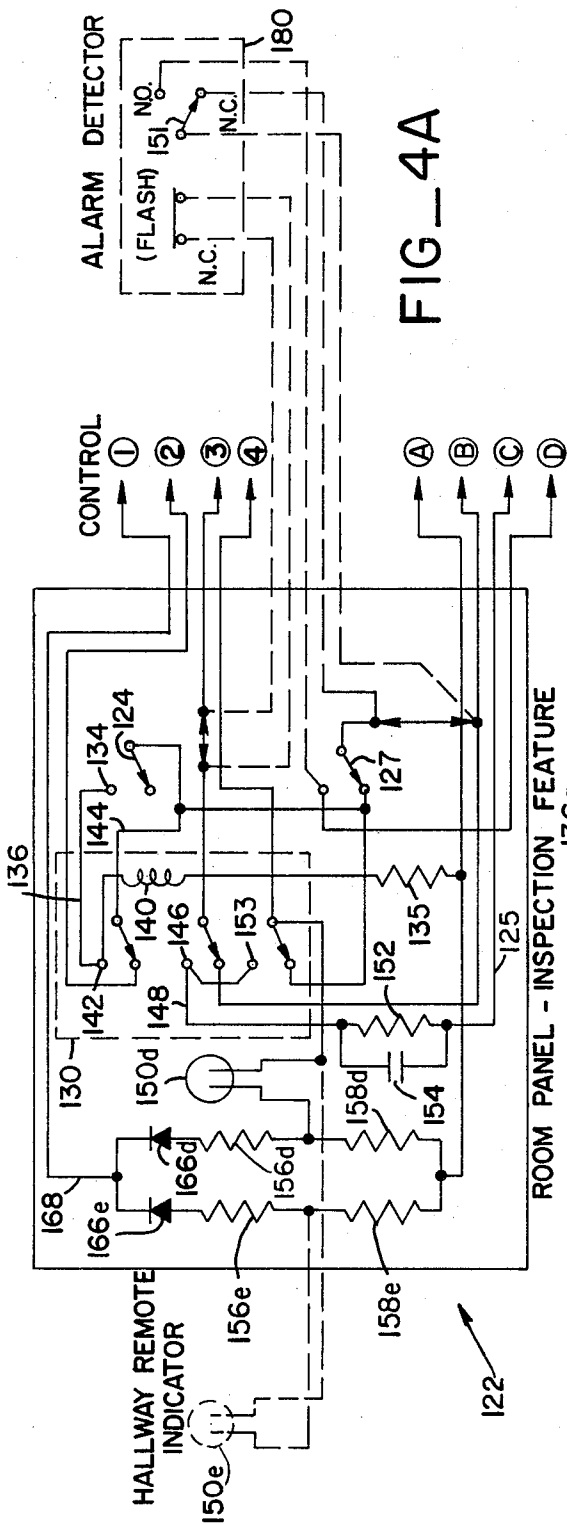

FIG. 4



INVENTOR.
CLEVELAND B. CRUDGINGTON, JR.

BY

Owen, Wickorsham & Strickson
ATTORNEYS

FIG_5

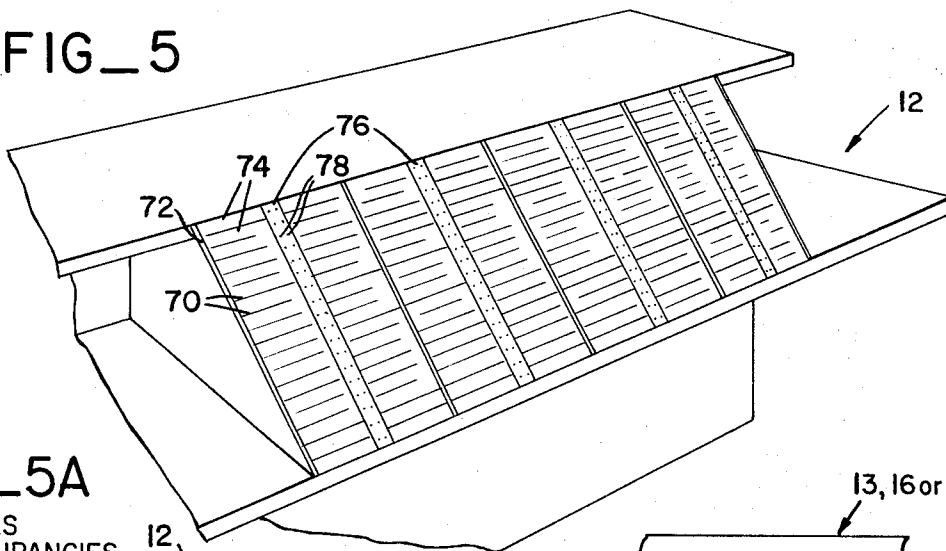

FIG_5A

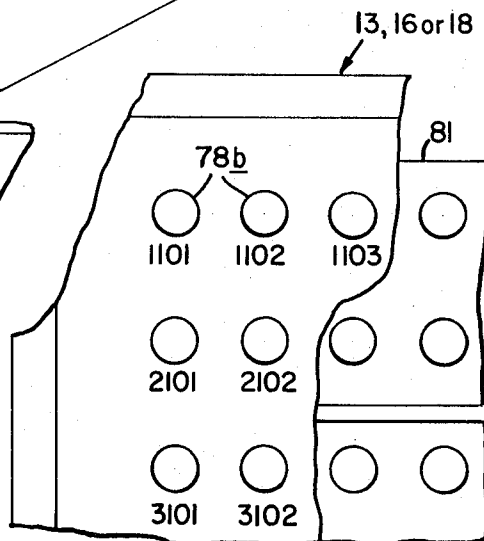
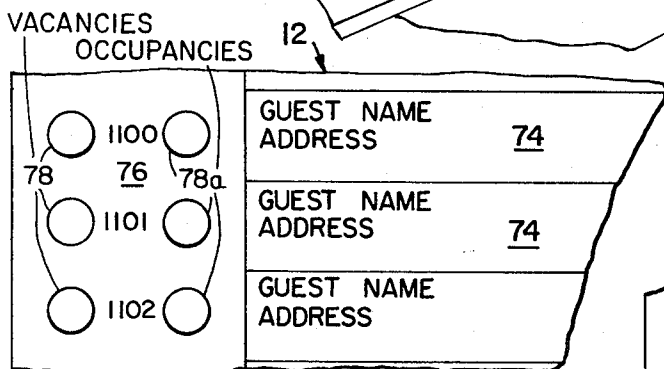

FIG_6

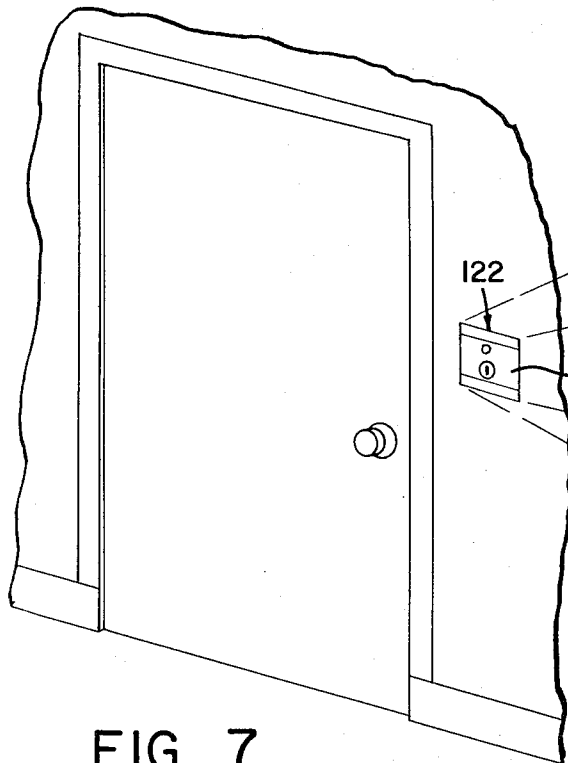

FIG_7

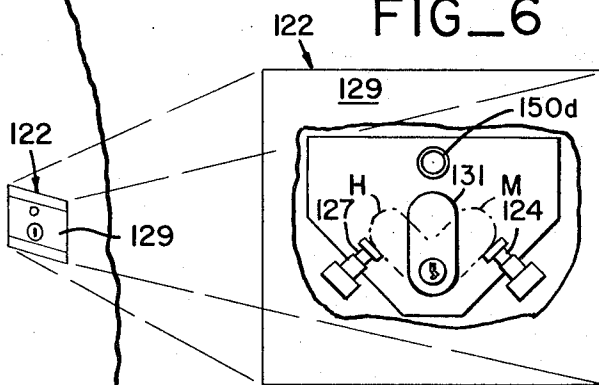

FIG_7A

INVENTOR.
CLEVELAND B. CRUDGINGTON, JR.

BY

Owen Wickham & Erickson
ATTORNEYS

ROOM STATUS SYSTEM FOR HOTELS

This invention relates to a room status system for hotels and the like.

For efficient hotel operations it is essential to provide means for determining the status or availability of rooms as guests check in and out. Systems heretofore devised to provide this function required or utilized complicated electronic circuitry and display apparatus. Consequently, they were not only expensive to install but often unreliable in operation and also required highly skilled personnel to service them.

A general object of the present invention is to provide a room status system for hotels that utilizes relatively simple electrical circuits and is therefore particularly well adapted for ease and economy of manufacture and installation.

Another object of the present invention is to offer a room monitoring or status system for hotels that is highly versatile in providing information, and yet a system which requires no complex electronic signaling components or switching circuits.

Another object of the present invention is to provide a system that can be readily expanded through the use of modular construction and plug-in assembly.

A more specific object of the present invention is to provide a room monitoring or status system for hotels which includes display panels utilizing neon lights for showing room status information.

As will be shown, the use of neon lamps as circuit components provides a simple and economical means of transferring indicator information.

Yet another object is to provide a system for monitoring hotel rooms that operates from ordinary available 110 volt a.c. power but is completely safe and compatible with the national electric codes, specifically the articles covering current-limited signaling systems.

The aforesaid and other objects are accomplished by a system that includes in its basic form a display console for the desk clerk, an optional display panel for the cashier, and room panels or floor panels which provide housekeeping information. In the system, neon indicator lamps, used as circuit components, are each connected to and controlled by a voltage divider circuit. Thus, the turning on and off of the indicator lamps throughout the entire system is controlled by the momentary switching of a voltage divider circuit.

Other objects, advantages and features of the present invention will become apparent from the following description thereof presented in connection with the accompanying drawings, in which:

FIG. 1 is a block diagram showing one form of a room monitoring system embodying the principles of the present invention;

FIG. 2 is a circuit diagram for the system shown in FIG. 1;

FIG. 3 is a block diagram for another form of room monitoring system according to the invention;

FIG. 4 is a circuit diagram for the system shown in FIG. 3;

FIG. 4A is a circuit diagram of one form of room panel for the system of FIG. 4;

FIG. 4B is a circuit diagram of another form of room panel for the system of FIG. 4;

FIG. 5 is a view in perspective showing a front desk console for the system of FIGS. 1 and 3;

FIG. 5A is an enlarged fragmentary view showing a portion of the clerk's console of FIG. 5;

FIG. 6 is an enlarged fragmentary view showing a portion of a typical cashier's or housekeeper's panel for the system of FIGS. 1 and 3;

FIG. 7 is a view in elevation showing a typical room panel installation for the system of FIGS. 3 and 4; and

FIG. 7A is a front view of the room panel shown in FIG. 7 with the cover plate broken away to show internal mechanical details.

Referring to the drawing, FIG. 1, a block diagram, shows one relatively simple form of room status system 10 embodying the principles of the present invention. Generally, it comprises a front desk monitoring console 11 which may be conveniently located at the clerk's station of a hotel or motel where new guests register or check in or acquire information on availability of rooms (See FIG. 5). The front desk console 11 usually incorporates vacancy and occupancy indicators with respective circuitry, 12 and 14, (See FIG. 2), to illustrate the status of all rooms. Normally, the clerk's monitoring console is connected electrically to an optional panel 13 at a cashier's station which in most larger hotels is located away from the clerk's station, and where guests check out and pay their bill. The cashier's panel normally would include occupancy indicators and circuitry in parallel with clerk's console occupancy indicators. The clerk's console or cashier's panel may be directly connected to a series of maid's floor panels 16, one of which is located usually on each floor. Or, as shown, in FIG. 1, the clerk's console or cashier's panel may be first connected to a central housekeeper's panel 18 installed at some convenient location in the hotel. The aforementioned panels are all supplied with power from a central source 20 and as described below, each has a series of indicator lights or combination button-light switches which are arranged with adjacent markings that designate a particular room.

The important structural and functional features of the system 10 will be more readily understood by reference to the detailed circuit diagram of FIG. 2. As shown, conventional 110 14 120 volt a.c. power is supplied to the power supply unit 20, which rectifies the a.c. input through a pair of leads 22 and 24 to provide a d.c. voltage output supply through a pair of positive and negative leads 26 and 28. A ground fault protection device 30 of any suitable type can be wired by two input leads 32 and two output leads 33 to the rectifier 20. If an isolated d.c. lead is accidentally grounded, causing more than a predetermined amount of current, i.e., 15 milliamps to flow from the rectifier to ground, the a.c. voltage supply to the rectifier 20 will cut off.

As shown in FIG. 2, the positive d.c. output lead 26 is connected (preferably through a milliamp fuse 34) to a common plus lead 36 that goes to the indicator circuitry 12 and to all the floor panels 16 (only one of which is shown), as well as the housekeeper's panel 18, if used. The negative lead 28 is connected to a common negative lead 38 that is similarly connected to all of the panels. A counter 40 or some suitable information storage or recorder device, preferably used with the system, is connected by a lead 42 through a fuse 43 to the d.c. power lead 26 and by leads 44, 46 and 48 to the vacancy indicator switch 78, the occupancy indicator switch 78a and floor panels indicator switch 78b respectively.

To conserve space, the diagram in FIG. 2 shows only the circuitry for one room at all panels, while in a complete system there would be similar circuits for all other rooms. In accordance with the present invention, each indicator light 50 on all panels is a small ionizing gas glow lamp such as a neon lamp, and each lamp is connected to its own control circuit, which is essentially a voltage divider comprised of a pair of resistors 56 and 58. As seen with reference to the clerk's panel in FIG. 2, each lamp is in parallel with the resistor 56 and is in series with the resistor 58. The series resistor 58 is connected to the common fused positive d.c. lead 36 while the parallel resistor 56 and lamp are connected to the negative d.c. lead 38 through various push button switches 80. The supply voltage between points 60 and 62 and the resistors 56 and 58 are valued so that the applied lamp voltage between points 64 and 62 is above the lamp's maintaining voltage but below the lamp's firing voltage. Thus, at any given time under this condition if the lamp was already on, it would remain on, or if it was already off, it would remain off. Now, if the parallel resistor 56 is momentarily disconnected from negative lead 38 by actuation of switch 80b, the voltage across the "off" lamp between the points 64 and 62 increases to equal the supply voltage since current flow through series resistor 58 ceases. The supply voltage is set at a level greater than the breakdown voltage of the neon lamp, thus the lamp will ignite. Once the lamp 50 ignites, its voltage between point 62 and 64 decreases to the lamp's maintaining voltage. As will be seen when the entire operation of the system is described, the disconnection of the parallel resistor 56 is triggered by operation of a button at another station. Extinguishing the lamp is accomplished by momentarily shorting or disconnecting the lamp circuit between points 60 and 62. This function is triggered by operation of the switch within the indicator assembly. The lamps and their associated control circuits for each room at all panels operate in the same manner throughout the system 10.

A typical front desk or clerk's console 11, as shown in FIGS. 5 and 5A, comprises a series of card-holder pockets 70 arranged in vertically aligned columns preferably on a sloped mounting board 72. These pockets can be of any suitable material such as metal or plastic and preferably large enough to hold standard room rack registration cards 74. The top portion of each card is left exposed when placed within a pocket to display the guest's name and other pertinent information. Adjacent to each column of card-holder pockets is a panel 76 having two columns of illuminating push-button switches 78 and 78a where each button is horizontally aligned with the exposed portion of the card in each pocket 70. The room number is printed adjacent to each button. The button lenses are all preferably constructed of a transparent plastic so that light can be transmitted through them from the lamps 50 and 50a located within the switch. The lenses may be of one color but it is preferable that each column be of a different color to distinguish vacancy from occupancy indicators. The electrical spring-loaded switch mechanism, behind each button, (designated by the numeral 80 in FIG. 2), will operate to open or close the contacts as the button is pressed. Such indicator switches are available commercially, so their structure need not be described in detail. Preferably, plug-in units with a predetermined number of button switches 78 and 78a with their associated circuitry are provided. From a series of

such plug-in units a console of any size can be easily constructed and additional units can be added when required.

As illustrated in FIGS. 2, 4, 4A and 4B every voltage divider circuit is located in proximity to the lamp which it operates. As a result, any induced line voltages will have no effect on the system operation, particularly lamps in the "off" state. Extinguished lamps, as well as illuminated lamps, are biased across their respective parallel resistors, and any anticipated induced voltage will cause the resulting current to bleed through these resistive circuits without significant change in lamp voltage.

The maid's floor panel 16 14, as shown in FIG. 6, is comprised of plug-in units 81 having a series of button-light switches 78b spaced apart and arranged in horizontal rows, there being one for each room with a number designation for the appropriate room adjacent to each button.

A cashier's panel 13, FIG. 1, similar in construction and appearance to the maid's floor panel 16 can be added to show room occupancy and even to transfer status information, thus taking the place of button-switch 78a in clerk's console. Such an arrangement might be desired by larger hotels having a separate cashier's station. The present trend is to omit the cashier's panel; hence, it has not been presented in FIG. 2.

A housekeeper's panel 18, as shown in FIG. 6, can be installed in the housekeeper's office and its construction and appearance are also similar to that of the cashier's panel and a maid's floor panel. If maid's floor panels are not used, the housekeeper's panel will have push-button indicator switches 78b, but if floor panels 16 are used in the system, the housekeeper's panel will have indicator lights 78c without switches.

A further understanding of the system 10 shown in FIGS. 1 and 2 will be apparent by the following description of its operation. Normally, rooms that are vacant and ready for occupancy will be indicated by appropriate illuminated lamps 50, column 78, FIG. 5A, only on the clerk's console 11. When a guest checks in, the clerk momentarily depresses the particular illuminated button switch 78 at his panel for that room. This action temporarily breaks normally closed switch contacts 82 and 84, FIG. 2, and closes its normally open contacts 86 and 88. In this temporary position, the normally open counter circuit is closed through the lead 44 to the (optional) counter 40 to register sale of the room. While the normally closed contact is broken, the lamp circuit is interrupted causing the light 50 to go out. Also, lead 93 is disconnected from supply lead 38, causing current to cease through the resistor 56a parallel with the corresponding occupancy lamp 50a. This causes the occupancy lamp to ignite because of the resulting increase in voltage at the occupancy lamp 50a to a level approximately equal to the d.c. output of the power supply 20, which is set above the firing voltage of all lamps. At this point, the light for this room at the housekeeper's panel, (50c), and at the respective floor panel, (50b), as well as the clerk's console are all "off" or non-illuminating. The only lamp that is lighted to show room occupancy is the lamp 50a located on the front desk console 11 and optional cashier's panel 13. When the guest is ready to leave and checks out, the clerk or the cashier will depress his switch 78a for the particular room. This momentarily moves the switch from its normally closed position, across contacts 82a,

84a to close normally open contacts 86a and 88a. Now, the counter circuit is closed to register vacancy of the room through these normally open contacts. With the breaking of the normally closed contacts, lead 91 is disconnected and the occupancy lamp circuit is broken, causing the lamp 50a to go out. Also, the current is discontinued through the resistors 56b and 56c in parallel with corresponding lamps 50b and 50c on the maid's floor panel 16 and optional housekeeper's panel 18. Discontinuing the current causes the lamps at these two stations to ignite by the resulting increase in voltage across the lamps to a level approximately equal to the d.c. output of the power supply 20 which here again exceeds the lamp firing voltage.

Thus, at this point, both the vacancy and occupancy lights 50 and 50a on the clerk's console 11 are "off" and both the respective maid's floor and housekeeper panel lamps 50b and 50c are "on" for this particular room. This display indicates to the maid and housekeeper that the room is vacated and requires maid service. When the room has been serviced and is again ready for occupancy, the maid will depress the illuminated switch 78b for the appropriate room on her particular floor panel. This action temporarily opens the circuit through a lead 90 to the enclosed illuminated lamp 50b as well as the corresponding illuminated indicator 50c on the housekeeper's panel 18 and causes both lamps to extinguish. Also, actuation of the maid's switch causes current to cease flowing through a continuation of the lead 90 connected to the parallel resistor 56 in the corresponding vacancy lamp circuit for the clerk's console. By the method previously described, the increased voltage applied to the vacancy lamp 50 causes it to ignite, thus completing the cycle. While the maid's switch 78b is in the depressed position, the normally open circuit to the counter through the lead 48 is completed, thus providing data to the counter on room availability. At the clerk's station a bell 92 may be provided which is connected by a pair of leads 94 and 96 to a bell control circuit 98, having a transformer that draws power from the incoming a.c. lines 22 and 24 to operate the bell. Another pair of leads 100 and 102 are connected to the d.c. power lead 26 and the counter lead 48, so that when the clerk's on-off bell switch 104 is closed, the bell will chime when a maid's button switch 78b is depressed.

The system 110 shown in FIG. 3 is essentially similar to that shown in FIG. 1 in that it includes a clerk's console 111, an optional cashier's panel 113, and a power supply 120 connected in a manner similar to power supply 20 for system 10. However, each room on all floors is provided with a separate room panel 122. All room panels on the same floor are connected to a floor terminal panel 116. Floor terminal panels may or may not include indicators. In addition to floor terminal panels, a housekeeper's panel with indicators only 118 may also be included in the system 110 by being connected to all of the floor terminal panels. Each floor terminal panel is essentially a junction point and provides connecting apparatus for wires from room panels, housekeeper's panel and clerk's console or optional cashier's panel.

FIG. 4, 4A and 4B show the circuitry of the system of FIG. 3. FIGS. 4A and 4B show alternate forms of room panels embodying the principles of the present invention.

The operation of the system 110 shown in FIG. 3 is identical to that shown in FIG. 1 with respect to clerk's console 111 for a guest checking in, guest checking out, and a vacant room made ready. The optional cashier's panel 113 also operates in a manner similar to cashier's panel 13 in system 10. The addition of the room panel adds a fourth mode to the operational sequence. In FIG. 4, a series of four leads A, B, C and D are connected in parallel to all of the room panels. Lead (A) is the common positive d.c. power lead; lead (D) is the common negative power lead; lead (C) is connected to a conventional flasher unit 121 connected to the negative power lead 128, whose function will be explained later. Lead (D) is connected to the counter 140 and bell equipment 198 in a manner similar to lead 48 in system 10, FIG. 2. In addition to the aforesaid common room panel leads A,B,C,D, each room panel is connected to four or five individual leads, depending on the type of room panel used, numbered (1), (2), (3), (4) and (5) from the floor terminal panel 116.

The system of FIG. 4 is adapted for use with at least two types of room panels. The room panel 122 shown in FIG. 4A enables the maid to indicate when a vacant room is ready for inspection. The room panel 122a shown in FIG. 4B enables the maid to indicate her location during room clean up, whether occupied or not. As shown in FIG. 7A, both of these room panels are comprised essentially of two momentary contact switches 124 and 127 which are activated by a spring-loaded lever 131; a relay 130 that engages a common flashing circuit 125; and an indicator 150d to illustrate room information. FIG. 7A shows the mechanical arrangement of the room panel mechanism with the lever 131 which is preferably key operated, covered by a face plate 129. FIG. 7 shows a typical installation for a room panel 122 which is conveniently located in a hallway adjacent to the door of the room. The room panel can be located inside the room necessitating the need for a remote hallway indicator, 150e.

In the circuit diagram of FIG. 4A, the switch 124 is shown in the open position. When closed, it contacts a terminal 134 which completes a circuit through lead 136 allowing current to flow through a limiting resistor 135 and activates relay coil 140. The energized coil operates the relay 130 which moves the first relay arm to a normally open contact 142, thereby completing a circuit through a lead 144 which continues to furnish current to the relay coil 140, after the momentary switch 124 is released. A second arm of the relay is moved to a normally open contact 146 which completes a flasher circuit 125 through a lead 148 to all housekeeping indicators 150b, c, d and e. Also, as the relay is actuated, its third arm, connected to the negative d.c. supply, is moved from a normally closed contact 151 which causes current to cease flowing through all resistors 156b, c, d and e, connected in parallel to the room panel indicator 150d and all other housekeeping lamps of the system such as a hall indicator 150e, a floor terminal panel lamp 150c if used, and housekeeper's panel lamp 150b for that particular room. Now, as the third switch arm engages a normally open contact 153, all of these housekeeping lamps, as well as the corresponding clerk's console lamp, immediately begin flashing because this normally open contact is connected to lead 148 of the flashing circuit. The lamps current through this flashing circuit lead 148 is reduced by means of a

resistor 152 in parallel with a capacitor 154. In accordance with the invention, all housekeeping lamps 150b, 150c, 150d and 150e are connected to individual voltage divider circuits which are in parallel and function as previously described for system 10 in FIG. 2. The voltage divider for the room panel lamp 150d comprises a pair of resistors 156d and 158d in series with a diode 166d. The voltage divider for the hall lamp 150e comprises a pair of similar resistors 156e in series with another diode 166e.

When two or more lamps are required to operate simultaneously the insertion of a diode 66 or 166 in each voltage divider circuit is necessary to prevent undesired reverse current flow. If one of a series of lamps in parallel ignites before the others, there is a reverse current flow through all of the voltage divider circuits connected to the non-illuminated indicators. This reverse current flow may prevent any of these lamps from igniting due to a resultant voltage drop across the respective series resistors causing a drop in the applied lamp igniting voltage. Insertion of the diode 66 or 166 in series with the lamp's parallel resistor 56 or 156 will prevent this unwanted reverse current flow.

Considering operation of system 110 incorporating the room panel 122 shown in FIG. 4A: When the maid has cleaned a vacated room she will call for inspection by turning lever 131 with her key to the "M" position, FIG. 7A, thereby depressing the first momentary contact switch 124. The relay 130 will engage and hold, causing housekeeping and vacancy lamps to flash for that particular room. When the inspector approves the cleaned room, she will turn the lever to the "H" position to activate the second momentary contact switch 127. This action breaks the circuit to the relay coil as well as the circuit to the respective housekeeping lamps. Relay 130 now disengages and all the flashing lights for that room will go out, (including the cashier's lamp if on) except for the clerk's console vacancy lamp 150 which goes on. The vacancy lamp ignites, since the resistor 156 in parallel with the vacancy lamp is also disconnected, causing the voltage across the lamp to increase, as previously described. While the momentary switch 127 designated H is activated, the normally open circuit to the counter 140 is completed, thus providing data on room availability. Also, if the clerk's bell switch 104 is "on", the bell will chime at the front desk.

In the circuit diagram of FIG. 4B, for the room panel 122a, the switch 124a is also shown in the open position. When closed, its arm closes a contact 134a which completes a circuit through lead 136a. Thus, a relay 130a having only two switch arms is activated and remains energized in the same manner as relay 130 in FIG. 4A. The normally open contact 142a of its first arm is closed and continues to supply current to the relay coil 140a after the momentary switch 124a is released.

As in the circuit diagram of FIG. 4A, a second arm of the relay 130a in the circuit of FIG. 4B is moved from the negative d.c. supply to a normally open contact 146a which completes a flasher circuit through lead 148a to all housekeeping lamps for that particular room. Now these lamps will flash. These flashing lamps are shut off by depressing the flashing room panel push-button indicator switch 172 (150d of FIG. 7A). Activating this switch closes a pair of contacts 174 thereby shorting the coil of relay 130a, causing it to disengage.

This push-button indicator switch also has a set of normally closed contacts 176 which open to disconnect the negative d.c. supply to insure that all previously flashing indicators for that room will remain off. These flashing lamps can also be shut off by activating the switch 127a using a key to actuate the lever 131. This breaks normally closed circuit and disconnects the relay coil circuit from the negative d.c. supply, causing the relay 130a to return to its normal position. Also, the opening of the normally closed contact of switch 127a breaks the negative d.c. voltage to the housekeeping and cashier's lamps for that particular room, causing them to go out, as with switch 127 in room panel 122. The resistor 156 in parallel with the vacancy lamp 150 for that room is also disconnected thereby causing this lamp to turn on in accordance with the principles of the invention. The normally open contact of this switch is made causing the clerk's bell to chime if desired and registering occupancy information at the front desk.

The room panel illustrated by FIG. 4B does not incorporate a room inspection feature like the room panel illustrated by FIG. 4A. When the maid begins servicing either an occupied or vacant room, she will turn the lever 131, FIG. 7A, to the "M" position, depressing the first momentary contact switch 124a, the relay 130a will engage and hold, causing the light 150d to flash at the room panel 122a and remote indicator light 150, as well as corresponding lights at the housekeeper's panel 150b and at a floor terminal panel having indicators 150c, (maid's floor panel). Unlike the room panel 122 illustrated in FIG. 4A, the vacancy light 150 will not flash at the clerk's console for that particular room. Whether the room is vacant or occupied, this information remains undisturbed at the front desk. When the maid has completed room servicing, she depresses the flashing button-light 150d mechanically connected to the switch 172 on the room panel causing all corresponding flashing lights to extinguish by disrupting the relay coil and lamp circuits. If the room is vacant, the lever 131 is turned to the H position, activating the second momentary contact switch 127a. As well as accomplishing the functions of the depressed button-light, the circuit to the resistor 156 in parallel with the clerk's lamp 150 is broken causing it to light. Also, the normally open circuit to the counter 140 is completed, thus providing data on room availability, as well as chiming the clerk's bell 192 if turned on. The room panel shown in FIG. 4B normally has five control leads and four leads in common with the other room panels. The two types of room panels are not compatible for use simultaneously since flashing information would not be differentiated.

If desired, the room panel shown in FIGS. 4A and 4B can be adapted to handle added features such as remote hallway indicator lights 150e, fire or T.V. theft detection devices 180, and telephone message indicators (not shown).

An alarm detector 180 controlled by any suitable sensor can be connected to either room panel, as shown in FIGS. 4A and 4B, so that the indicator for the room in distress will flash rapidly at the clerk's console. Also, an alarm will sound. The rapidly flashing lamp can be readily distinguished from the normal flashing lamp.

From the foregoing it should be apparent that the present invention provides a unique and highly versatile room status system for hotels and the like. The

combination of the neon indicator lamps in the various panels and their voltage divider controls makes possible relatively simple but reliable installation providing fast, convenient and positive communication that greatly enhances the efficiency of hotel operations. These long lasting neon lamps used throughout the system increase reliability, reduce maintenance. They allow the panels at the various stations to be relatively small and easily understood, since each room is represented by just one illuminated button. Face plates on the panels can be easily removed, making cleaning trouble-free and easily done without interference to hotel operation. Expensive field servicing is eliminated because the relative simplicity of the circuits will permit modular construction and thus fast replacement of any component. Shock and fire are prevented. A U.L. approved ground fault circuit interrupter and over-current protection provide split second safety. Installation costs can be low for new or existing structures using pre-assembled plug-in cables and pre-wired components, and the system can be enlarged in the event of hotel expansion.

To those skilled in the art to which this invention relates, many changes in construction and widely differing embodiments and applications of the invention will suggest themselves without departing from the spirit and scope of the invention. The disclosures and the description herein are purely illustrative and are not intended to be in any sense limiting.

I claim:

1. A signalling system for an institution having a central station and a plurality of locations remote from said central station comprising:

a central panel means at said central station including a first and second switch means and a first and second visual indicator means for each said remote location, and a power source;

a remote panel means located away from said center station including a third switch means and a third visual means for each said remote reporting locations; energized by said central power source;

said signalling system being adapted to report and direct the status at the respective stations in a predetermined sequential order; and

each of said first, second and third visual indicator means comprising an ionizing gas glow lamp and a control circuit with switch; whereby momentary activation of said first switch means momentarily reduces applied voltage at said first lamp to a level below minimum voltage necessary for continued ionization, as well as momentarily increasing applied voltage at said second lamp to a level above the minimum voltage necessary for initial ionization; momentary activation of said second switch means momentarily reduces applied voltage at said second lamp to a level below minimum voltage necessary for continued ionization, as well as mo-

mentarily increasing applied voltage at said third lamp to a level above the minimum voltage necessary for initial ionization; momentary activation of said third switch means momentarily reduces applied voltage at said third lamp to a level below minimum voltage necessary for continued ionization, as well as momentarily increasing applied voltage at said first lamp to a level above the minimum voltage necessary for initial ionization.

2. A sequential signalling system as set forth in claim 1 wherein said control circuit means for each said visual indicator applies a voltage to said gas glow lamp at a level above the minimum voltage necessary for continued ionization and below the minimum voltage necessary for initial ionization; wherein the aforesaid condition prevails during inactivation of said switch means; whereby said gas glow lamp will remain "off" or "on" dependent upon the previous activation of said switch means.

3. The system as described in claim 2 wherein all of the visual indicators for all of the panels comprise indicating lamps; where the highest operating voltage for any said indicating lamp is below the lowest turn-on voltage for any other said indicating lamp.

4. The system as described in claim 3 wherein said control circuit means for each visual indicator-switch means comprises a voltage divider circuit including a first resistor in parallel with said gas glow lamp and a second resistor in series with said lamp; said associated controllable switch means at the remote location being connected to remove said first resistor electrically from the circuit and thereby increase the voltage at said lamp above the initial ionization level while the controllable switch means is being actuated.

5. A signalling system as set forth in claim 4 with additional panel means including visual indicator means to duplicate information displayed by said first, second or third indicator means, or a combination thereof; and each said additional visual indicator means is connected in parallel to first, second or third visual indicator means and comprises a voltage divider circuit including a first resistor in parallel with said additional gas glow lamp and a second resistor in series with said additional lamp; and each said first resistor of all said paralleled lamps includes a current rectifying device for preventing reverse current flow, thereby insuring that all said parallel lamps representative of a particular reporting station will light when their respective control circuits are uniformly actuated by the activation of a particular switch means.

6. A signalling system as set forth in claim 5 wherein each of said third visual indicator means, said control circuit means, and said third switch means is located at a different remote panel; each of said remote panels disposed at locations remote from one another.

* * * * *