

J. F. Wood.

Tool.

N^o 102,459.

Patented Apr. 26, 1870.

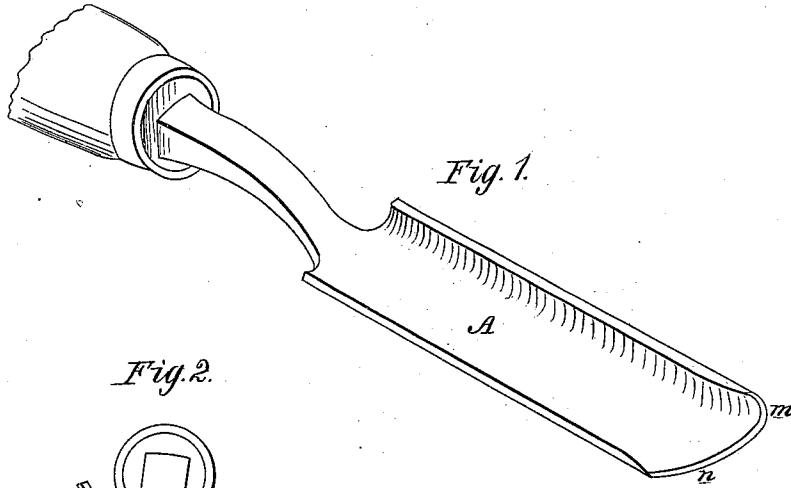

Fig. 2.

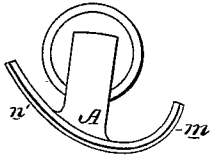

Fig. 4.

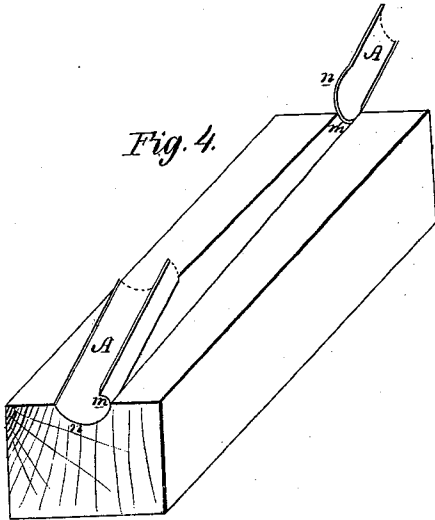

Fig. 3.



Witnesses:
Louis Beswell,
John Parker

Inventor:
Jas. F. Wood
By his Atty,
H. Howse,

United States Patent Office.

JAMES F. WOOD, OF PHILADELPHIA, PENNSYLVANIA.

Letters Patent No. 102,459, dated April 26, 1870.

IMPROVEMENT IN GOUGE.

The Schedule referred to in these Letters Patent and making part of the same.

To all whom it may concern:

Be it known that I, JAMES F. WOOD, of Philadelphia, Pennsylvania, have invented an Improved Gouge; and I do hereby declare the following to be a full, clear, and exact description of the same.

My invention consists of a gouge, the blade of which is so formed that its cutting-edge, instead of being in the arc of a circle, shall coincide with a parabolic curve or with a portion of an ellipse or oval figure, so that the tool can be used for a class of work which has heretofore required several gouges of different sizes to complete.

In order to enable others skilled in the art to make and use my invention, I will now proceed to describe the mode of constructing and using the same, reference being had to the accompanying drawing which forms a part of this specification, and in which—

Figure 1 is a perspective view of my improved gouge;

Figure 2, a view of the cutting-edge;

Figure 3, a diagram, illustrating a mode of forming the gouge; and

Figure 4, a diagram showing the advantages of my invention.

The blades of curved gouges have heretofore consisted of longitudinal sections of hollow cylinders or of sections of flattened or other shaped tubes, the cutting-edges of such tools being regular in shape, that is, the portions of the edge of a tool on both sides of a central point corresponding to each other in shape; it is necessary, therefore, for pattern-makers, cabinet-makers, and other workers in wood to keep a stock of gouges having cutting-edges representing arcs of circles of different diameters adapted to different work.

In order to obviate the necessity of purchasing a costly array of these instruments, I so form the blade A of a gouge that its cutting-edge shall coincide with such a portion of an ellipse or oval that the portions of the edge on opposite sides of a central point shall

be of different forms or degrees of curvature, it being preferable to make the gouge so that its cutting-edge shall coincide with a parabolic curve, as in fig. 3, the formation of which will be readily understood without explanation.

An example of the advantages of my invention is illustrated on fig. 4, where H represents half of a box for making tapering cores to be used in molding tapering pipes.

To make a box like this with ordinary gouges is a matter of no little difficulty, owing to the variation in size of the groove x throughout the length of the box.

By my improved gouge, however, the portion m on one side of the central point x' of its cutting-edge may be applied to the formation of the small end m' of the groove in the box, and the operator, as he pushes the gouge toward the opposite end of the box, may gradually turn the tool in his hand until the portion n of its cutting-edge acts on the edge n' of the recess x of the box.

It will be readily understood by operators in wood that my improved gouge may be used to great advantage in many other cases where a number of different sized gouges are usually required to complete the work.

I claim as my invention and desire to secure by Letters Patent—

A gouge, so formed that its cutting-edge shall coincide with a parabolic curve or a portion of an ellipse, oval, or other equivalent form, for the purpose specified.

In testimony whereof I have signed my name to this specification in the presence of two subscribing witnesses.

JAS. F. WOOD.

Witnesses:

LINDLEY HAINES, Jr.,

WM. E. WOOD.