



US00D765931S

(12) **United States Design Patent** (10) **Patent No.:** **US D765,931 S**
Presnell (45) **Date of Patent:** **** Sep. 6, 2016**

(54) **STRING MOP HEADBAND**

FOREIGN PATENT DOCUMENTS

(71) Applicant: **Rubbermaid Commercial Products, LLC**, Winchester, VA (US)

CN 302905274 * 8/2014
GB 3024560 * 7/2006

(72) Inventor: **Donald C. Presnell**, Stephens City, VA (US)

OTHER PUBLICATIONS

(73) Assignee: **Rubbermaid Commercial Products, LLC**, Winchester, VA (US)

Amazon.com: Carlisle 369819B00 #32 5" Cotton Head Band X-Large Cut-End Wet Mop, website copyright 2016, http://www.amazon.com/Carlisle-369819B00-Cotton-X-Large-Cut-End/dp/B00ED1YZVW/ref=sr_1_2?ie=UTF8&qid=1460858776&sr=8-2&keywords=string+mop+head+band, [site visited Apr. 16, 2016 10:07:42 PM].*

(**) Term: **14 Years**

(21) Appl. No.: **29/506,754**

(Continued)

(22) Filed: **Oct. 20, 2014**

Primary Examiner — John Windmuller

(51) **LOC (10) Cl.** **04-01**

Assistant Examiner — John R Yeh

(52) **U.S. Cl.**
USPC **D32/50**

(74) *Attorney, Agent, or Firm* — Sutherland Asbill & Brennan LLP

(58) **Field of Classification Search**
USPC D32/35, 38-42, 49-53, 71-72, 15, 17, D32/21-22, 31
CPC A47L 13/18; A47L 25/00; A47L 13/20; B05D 1/36; B29C 44/04; C08K 5/00
See application file for complete search history.

(57) **CLAIM**
I claim the ornamental designs for a string mop headband, as shown and described.

(56) **References Cited**

DESCRIPTION

U.S. PATENT DOCUMENTS

3,981,040	A *	9/1976	Crofton	A47L 13/20
					15/229.2
D345,791	S *	4/1994	Middleman	D24/124
D418,954	S *	1/2000	Ferdenzi	D28/63
D426,039	S *	5/2000	Tintelnot	D32/40
6,270,166	B2 *	8/2001	Weichelt	300/21
D462,150	S *	8/2002	Rader	D32/40
D575,918	S *	8/2008	Rosenzweig	A47L 13/225
					D32/40
7,694,379	B2 *	4/2010	Glaug	A47L 13/20
					15/209.1
D649,311	S *	11/2011	Colangelo	D32/40
D650,540	S *	12/2011	Fiumefreddo	D32/50
D669,648	S *	10/2012	Bilger	D32/40
D716,512	S *	10/2014	Layevsky	D32/40

FIG. 1 is a perspective view showing our new design for a string mop headband;
FIG. 2 is a front view showing our new design shown in FIG. 1;
FIG. 3 is a back view showing our new design shown in FIG. 1;
FIG. 4 is a left side view showing our new design shown in FIG. 1;
FIG. 5 is a right side view showing our new design shown in FIG. 1;
FIG. 6 is a top view showing our new design shown in FIG. 1; and,
FIG. 7 is a bottom view showing our new design shown in FIG. 1.

(Continued)

1 Claim, 5 Drawing Sheets

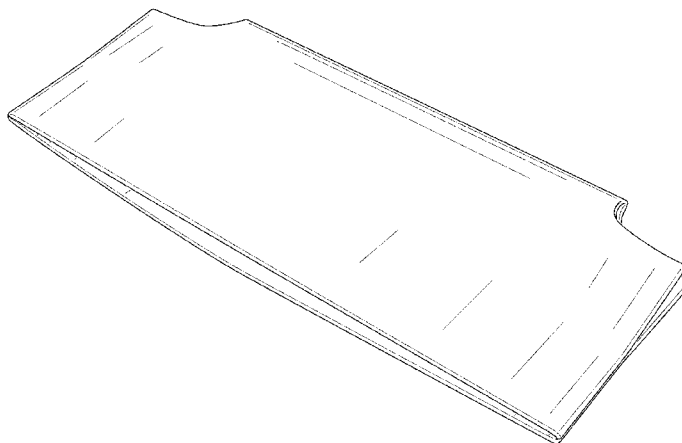

(56)

References Cited

U.S. PATENT DOCUMENTS

D717,009 S * 11/2014 Layevsky D32/40
D720,904 S * 1/2015 Weeks D32/40
9,010,873 B2 4/2015 Williams et al.
D731,137 S * 6/2015 Colangelo D32/40
9,113,768 B2 * 8/2015 Wada A47L 13/20
D740,052 S * 10/2015 Jalbert D6/582
D747,055 S * 1/2016 Layevsky D32/50
2001/0000545 A1 * 5/2001 Weichelt A47L 13/20
15/228
2003/0005535 A1 * 1/2003 Hale A47K 7/02
15/209.1
2007/0294931 A1 * 12/2007 Kettles A47L 13/16
42/95
2010/0269282 A1 * 10/2010 Kaminer A47L 13/20
15/209.1

2010/0272948 A1 * 10/2010 Kaminer A47L 13/20
428/100
2012/0060312 A1 * 3/2012 Kubes A47L 13/16
15/228
2014/0190958 A1 * 7/2014 Koch H01B 7/292
219/548
2015/0329796 A1 * 11/2015 Serita C09D 171/02
428/623

OTHER PUBLICATIONS

Boardwalk LM30311L Cotton Mop Heads, http://www.amazon.com/Boardwalk-LM30311L-Cotton-Synthetic-Wideband/dp/B004MDM7SY/ref=sr_1_5?ie=UTF8&qid=1460858776&sr=8-5&keywords=string+mop+head+band, [site visited Apr. 16, 2016 10:10:06 PM].*

* cited by examiner

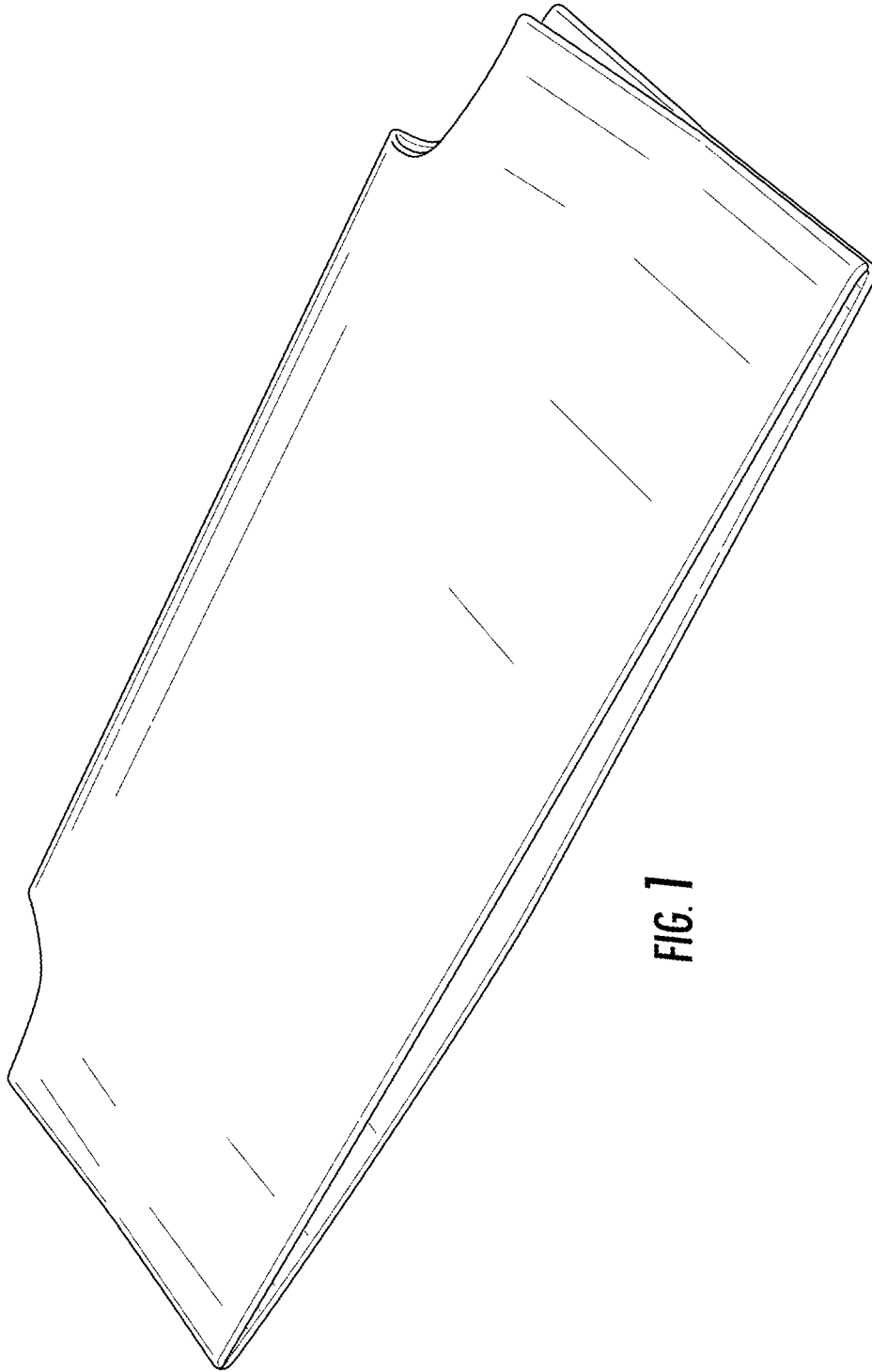

FIG. 1

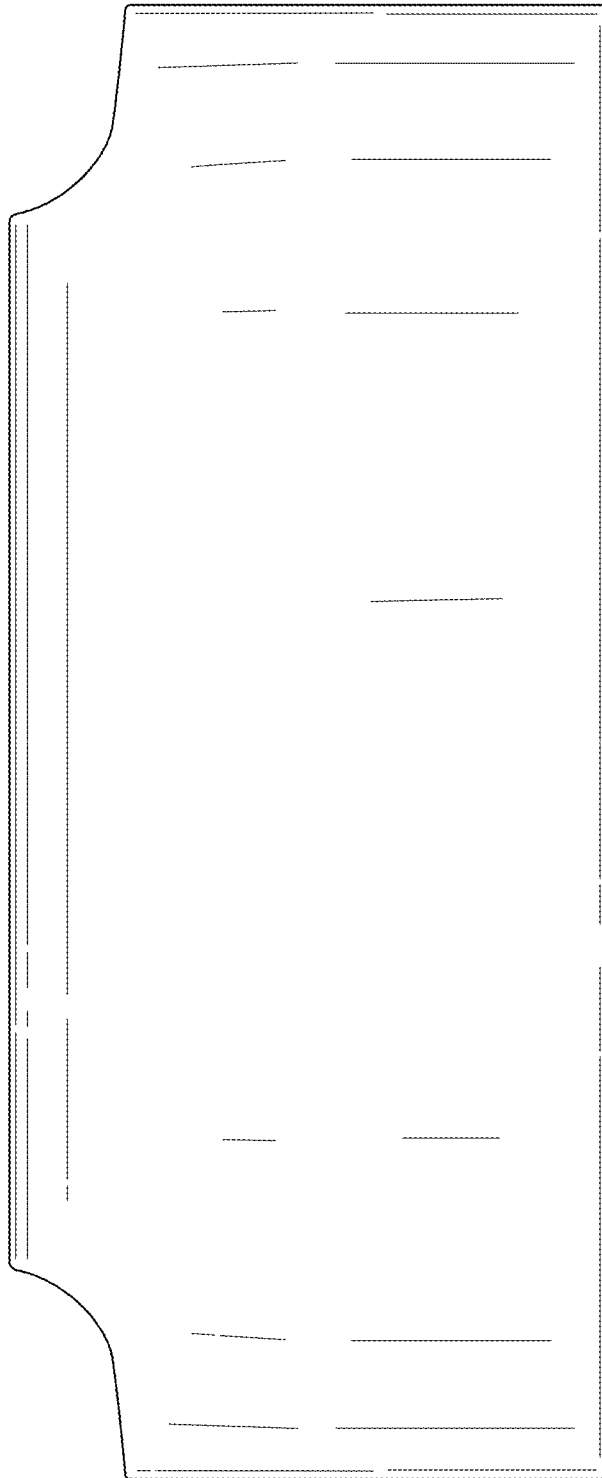

FIG. 2

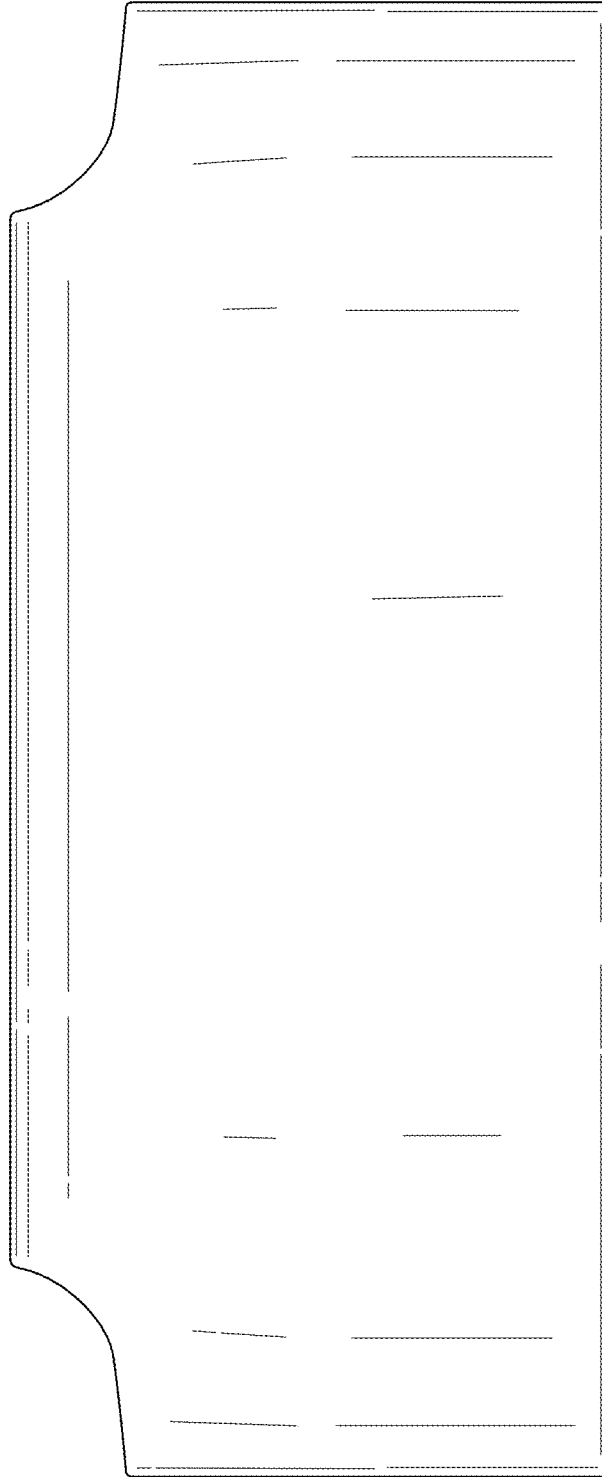

FIG. 3



FIG. 4

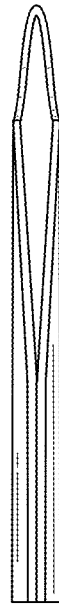

FIG. 5

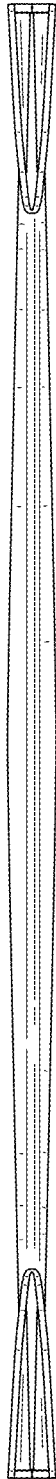

FIG. 6

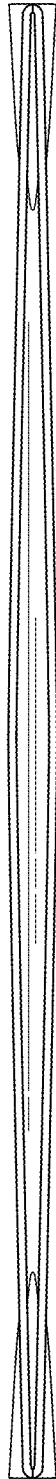

FIG. 7